



HAWK
ENTERPRISES

TigerHawk 1410

Small Area Orbital Floor Machine
Dry Stripping, Scrubbing, Stripping

Operation • Care • Service



Service Information	2
Machine Specifications	3
Features	3
Important Safety Instructions.....	4
Grounding Instructions	5-6
Operations	7
Guidelines For Operations	7
Controls.....	7
Adjustments.....	8
Cord Storage	8
Clean Up And Storage	8
TigerHawk Assemblies	9-14
Optional Accessories.....	15
Limited Warranty	Back Cover

SERVICE INFORMATION

To obtain consistent performance over the life of your equipment, read through these instructions and save them for future reference. If you require service, contact the dealer from which the machine was purchased or an authorized service station.

Always refer to your limited Warranty for complete service information.

The model, type, and serial number are indicated on the data plate on the side of the handle. From prompt and complete service, refer to these numbers when inquiring about service.

SERIAL NO.	MODEL		
VOLTS	PHASE	HZ	
MOTOR	AMPS	H.P.	

Write the model and serial number of your unit in the space provided. Refer to the data plate on unit.	
SERIAL #	MODEL #
Retain this owners manual for future reference.	

Revolutionary Design that Utilizes . . .

- Primary vibration isolators
- Secondary vibration isolators
- Floating head to ensure 100% pad contact at all times

Features	
<ul style="list-style-type: none"> • Start/Run capacitor 1/2 HP TEFC (totally enclosed fan cooled) motor keeps out dirt and dust for longer motor life. • Extra heavy duty spring steel cord strain relief with a 50' 14-3 power cord • Low current draw • Thumb-operated safety switch • Negative pressure on/off switch • Dual steel operating triggers for left- or right-hand operation 	<ul style="list-style-type: none"> • One-piece industrial powder coated heavy duty steel handle for optimum durability • Welded frame for rugged, reliable performance • Non-marking, 5" ball bearing wheels • Multiple position handle adjustment for operator comfort and safety • Comfort style vinyl handle grips for ease of use • Full wraparound dust skirt

Model #	TH-1410
Part #	F-TIGER1410
Pad Size	14" X 10"
Pad Driver Type	Combination Pad Holder/Diamond Pad Driver
Power Source *	115V 50/60Hz
Motor/HP	.5 HP TEFC 1725 Rpm
Amp Draw	8.3
Vibration Isolators	Primary and Secondary
Cord	50' 14-3 STJOW
Pad Pressure (lbs/in ²)***	.57
Pad Pressure (lbs/ft ²)***	81.26
Total Weight **	107
Shipping Weight	119
<p>*Unit also available in 230V, and 50 Hz **Weight is calculated without the power cord ***Pad pressure does not include the weight of the power cord. <i>Specifications subject to change without notice.</i></p>	

Miscellaneous Pads

White	A0065-1410-CS
Red	A0066-1410-CS
Blue	A0067-1410-CS
Green	A0068-1410-CS
Black	A0069-1410-CS
Light Hoghair	A0070-1410-CS
Safire	A0071-1410-CS
Green Astro	A0072-1410-CS
Red Heat Screen - 80 Grit	A0074-1410-80
Red Heat Screen - 120 Grit	A0074-1410-120
Red Heat Screen - 180 Grit	A0074-1410-180

All units to be operated with red backer pad.

IMPORTANT SAFETY INSTRUCTIONS

When using an electrical appliance, basic precautions should always be followed, including the following:



WARNING:

ELECTRIC SHOCK CAN CAUSE SERIOUS INJURY OR BE FATAL. PLEASE READ THE FOLLOWING INSTRUCTIONS ON THE USE AND OPERATIONS OF FLOOR FINISHING MACHINES.

- Your TigerHawk is equipped with a safety switch lock and power switch triggers designed for your safety. Do not attempt to bypass or defeat the safety switch lock. Never use any device to lock the power switch triggers in the “ON” position.
- Do not leave the TigerHawk plugged in. Turn off the switch and unplug the electrical cord when not in use and before servicing or changing the brushes or pads.
- Do not allow the machine to be used as a toy. Close attention is necessary when used near children. Do not leave the machine connected to an electrical outlet unattended.
- Use only as described in this manual. Use only manufacturer’s recommended attachments.
- Do not use with a damaged cord or plug. If the machine is not working as it should, has been dropped, damaged, or left outdoors, return it to a service center before using.
- Use care to keep the electrical supply cord around sharp edges or corners. Keep the cord away from the heated surfaces.
- Connect to properly grounded (3-wire) outlet only. Refer to Grounding Instructions, Page 5-6.
- Do not use extension cords or outlets with inadequate current carrying capacity.
- Turn off all controls before unplugging.
- Do not unplug by pulling on the cord. To unplug, grasp the plug and pull.
- Do not handle the plug or TigerHawk with wet hands.
- Wind the cord no tighter than is necessary to retain it during storage. Refer to Cord Storage, Page 8.
- Use extra care when working on or near stairs.
- Do not use in conjunction with flammable or combustible liquids such as gasoline, or use in areas where explosive vapor or dust may be present.
- Store your TigerHawk indoors in a cool, dry area.
- Keep your work area well lighted.
- **WARNING:** To avoid electrical shock, use indoor only.



WARNING:

RISK OF EXPLOSION. FLOOR SANDING MACHINE CAN RESULT IN AN EXPLOSIVE MIXTURE OF FINE DUST AND AIR. USE FLOOR SANDING MACHINE ONLY IN A WELL-VENTILATED AREA, FREE FROM ANY FLAME OR MATCH

GROUNDING INSTRUCTIONS

This appliance must be grounded. If it should malfunction or break down, grounding provides a path of least resistance for electric current to reduce the risk of electric shock. This appliance is equipped with a cord that has an equipment-grounding conductor and grounding plug. The plug must be plugged into an appropriate outlet that is properly installed and grounded in accordance with all local codes and ordinances.

FOR FLOOR FINISHING MACHINES RATED LESS THAN 150 VOLTS

Improper connection of an equipment grounding conductor can result in risk of electric shock. Check with a qualified electrician or service person if you are in doubt as to whether the outlet is properly grounded. Do not modify the plug provided with the appliance. If it will not fit the outlet, have a proper outlet installed by a qualified electrician. This appliance is for use on a nominal 120 volt circuit and has a grounding plug that looks like the plug illustrated in Figure 1.

A temporary adapter which looks like the adapter illustrated in Figure 2 may be used to connect this plug to a two pole receptacle, as shown, if a properly grounded outlet is not available. The temporary adapter should be used only until a properly grounded outlet (Figure 1) can be installed by a qualified electrician. The green colored rigid ear, lug, or the like extending from the adapter must be connected to a permanent ground such as a properly grounded outlet box cover. Whenever the adapter is used, it must be held in place by metal screw.

FOR FLOOR FINISHING MACHINES RATED 150-220 VOLTS:

If the machine is provided with an attachment plug cap as shown in Figure 3, it is intended for use on a 240 volt (nominal) circuit. No adapter is available for this cap.



WARNING:
DO NOT USE GROUNDING
ADAPTERS ON TIGERHAWKS IN
CANADA. CHECK WITH CANADIAN CODE
FOR PROPER EQUIPMENT USAGE.
IMPROPER USE OF GROUND ADAPTORS CAN
CAUSE SERIOUS INJURY, FIRE, OR BE FATAL.

Grounding Instructions (Continued)

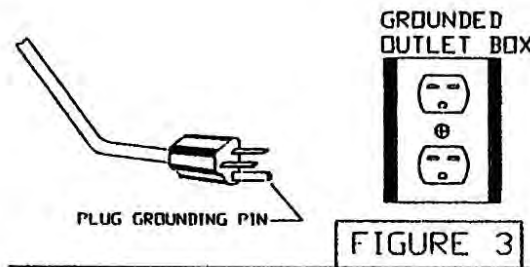
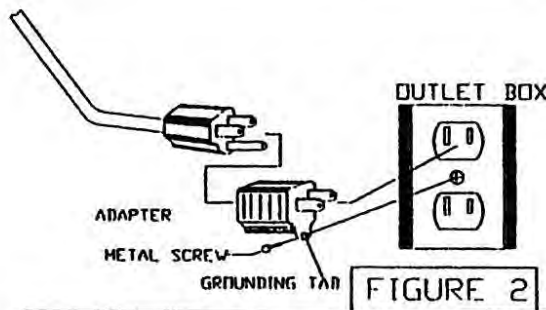
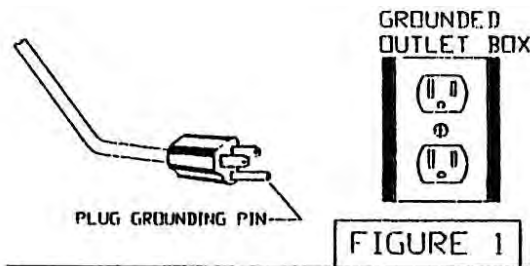

CONTROLS

TO TURN THE MACHINE ON

The operating handle must be lowered and locked to the proper operating position before switching the machine ON. Place both hands firmly on the handle grips with your fingers around the power triggers. **Do NOT** apply pressure on the triggers before the safety switch lock is disengaged.

Disengage the safety switch lock by pushing it forward with one thumb. Then, while holding the safety switch lock in the disengaged position, squeeze the power triggers toward the handle grips and return your thumb to the handle grip.

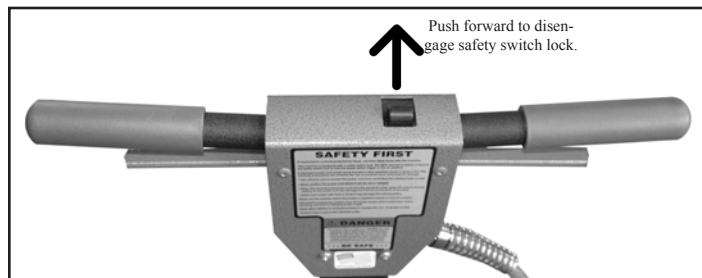

To stop the machine, simply release the triggers. The safety switch lock will automatically return to the engaged position.

GUIDELINES FOR OPERATION

- Your TigerHawk is a very sensitive, powerful unit. When in operation, it should be guided gradually and smoothly without sudden or rough motions. You will want to practice with your machine on a smooth surface until you have experience in operating it.
- For ease of operation, always keep the brush or pad surface level, balanced, and flat on the floor at all times.
- Always adjust the operating handle to a comfortable height at which the brush or pad surface is balanced before starting the machine. (See Handle Adjustment Page 4)
- Your TigerHawk will operate differently on various surfaces. For example, there will be much more resistance when the machine is used on a rough surface, than when it is used on a smooth surface. The operator should be prepared to adjust for these differences.
- **BEGIN OPERATING THE TIGERHAWK WITH THE PAD SURFACE LEVEL, BALANCED AND FLAT ON THE FLOOR.**
- To move the machine to the right, turn the unit to the right..
- To move the machine to the left, turn the unit to the left.
- To move the machine forward or backward, keep the brush or pad flat on the floor and push or pull the machine in the desired direction.

ADJUSTMENTS HANDLE ADJUSTMENT

The handle can be adjusted to any desired work position by simply pulling on the pull pin and move the handle to the desired position. Firmly push the pull pin back into the adjustment holes. This will lock the handle in position.



Figure 5

CORD STORAGE

When not in use, loosely coil the power cord and hang on the handle.



CLEANUP AND STORAGE

After being used, your TigerHawk can be wiped clean with a soft damp cloth and should be stored in a clean, dry place.

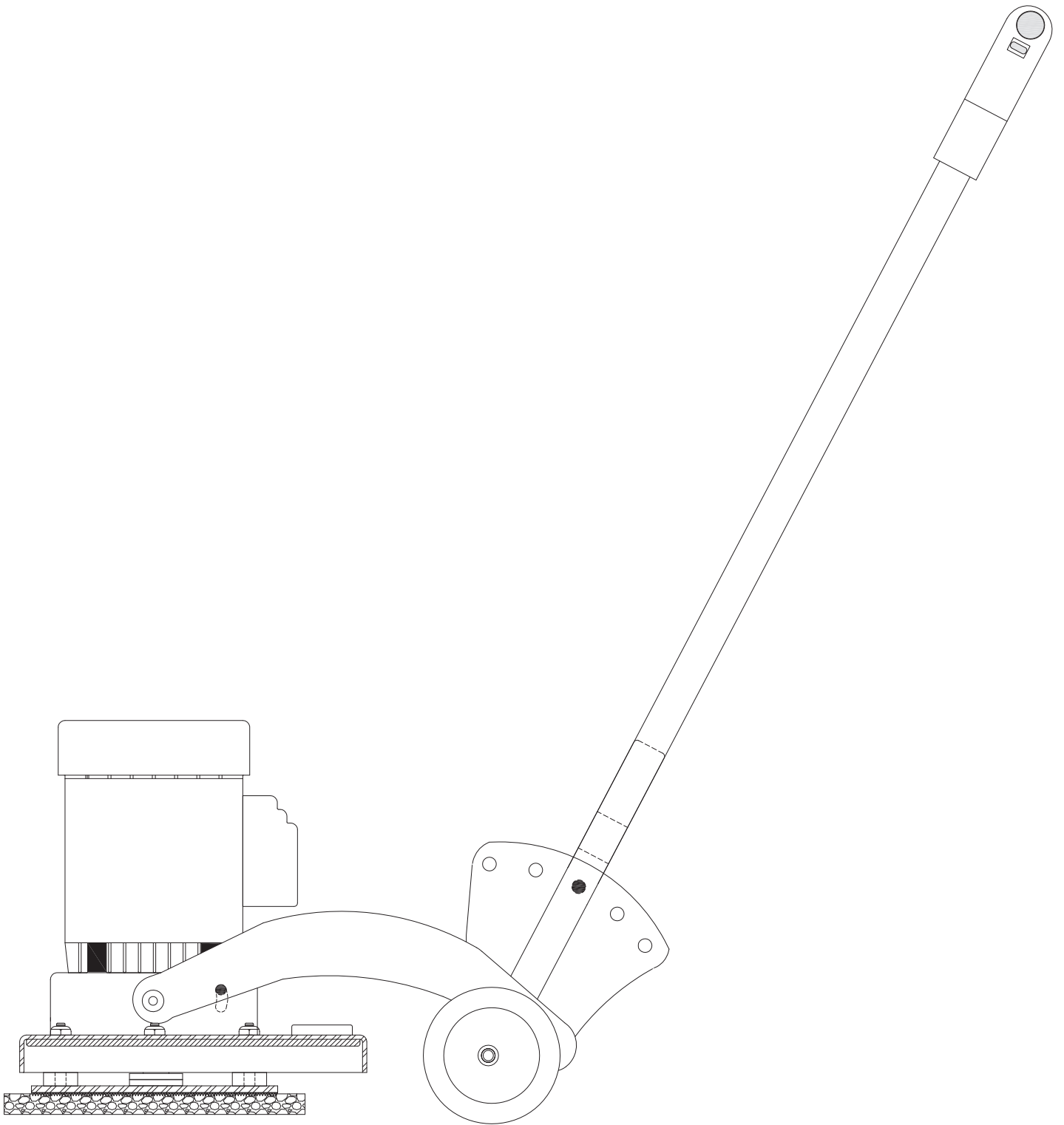

INSTALLATION OF MOTOR AND ISOLATORS TO FRAME

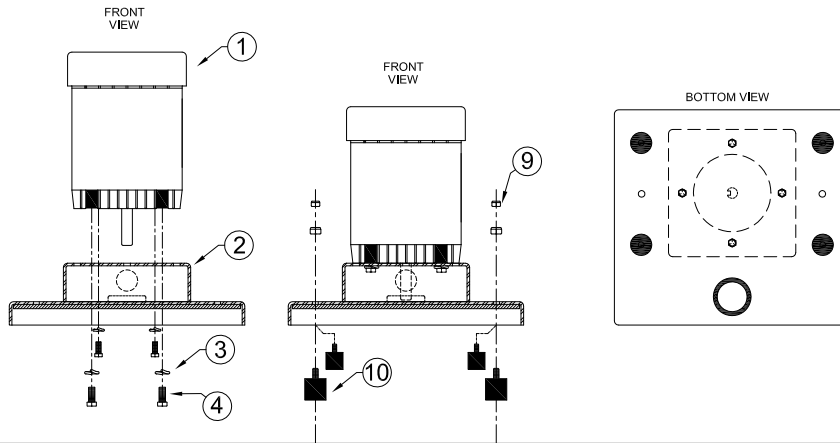

INSTALLATION OF STANDARD (2) BOTTOM WEIGHTS

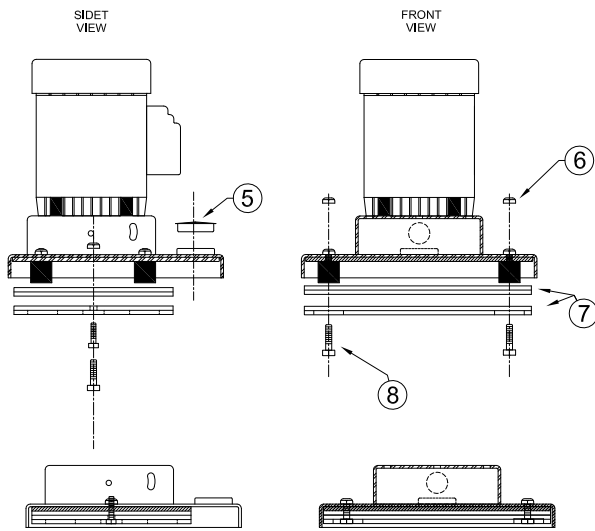

ISOLATORS NOT SHOWN FOR CLARITY

INSTALLATION OF OPTIONAL (3) BOTTOM WEIGHTS

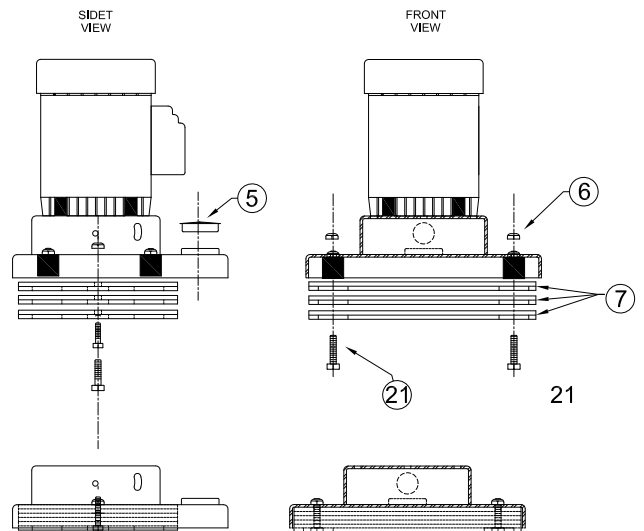

ISOLATORS NOT SHOWN FOR CLARITY

INSTALLATION OF ISOLATORS TO MAIN FRAME AND CARRIAGE

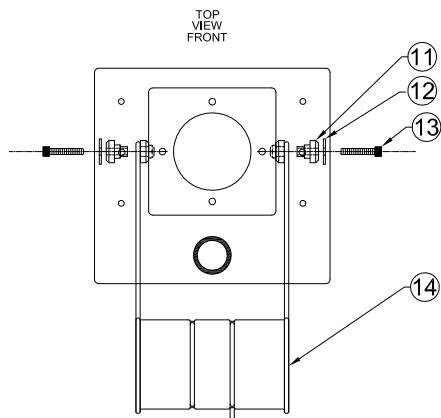

INSTALLATION OF ECCENTRIC & PAD DRIVER ISOLATOR SPACERS TO MAIN FRAME

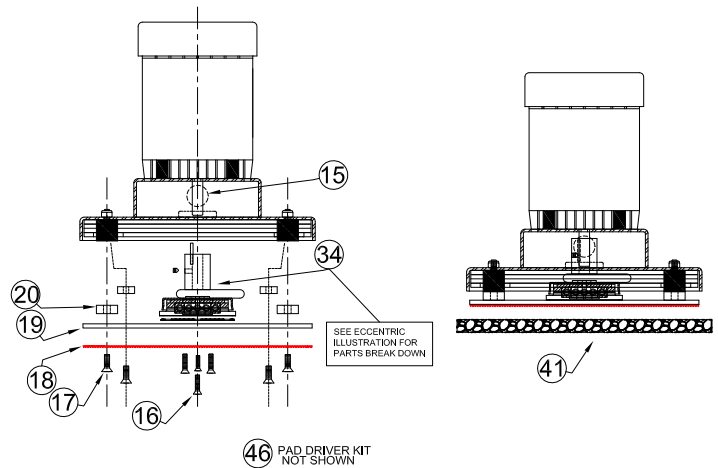

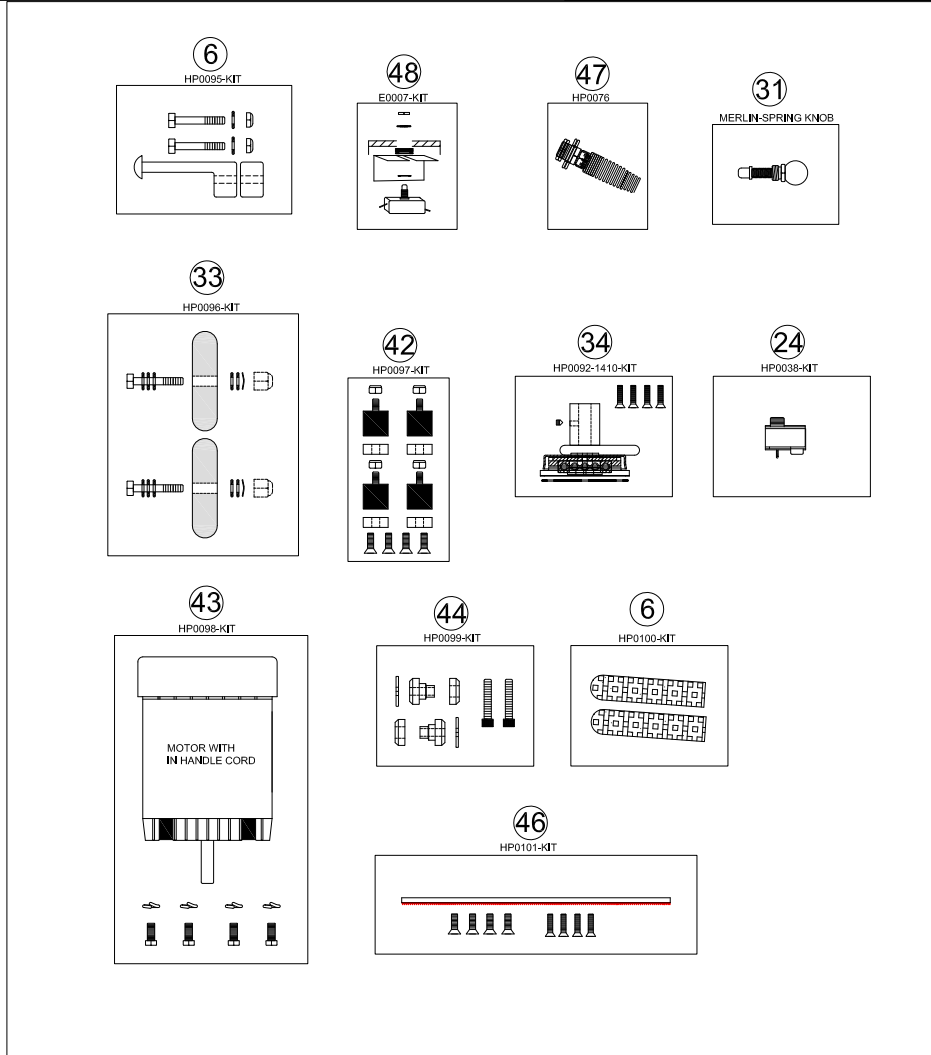
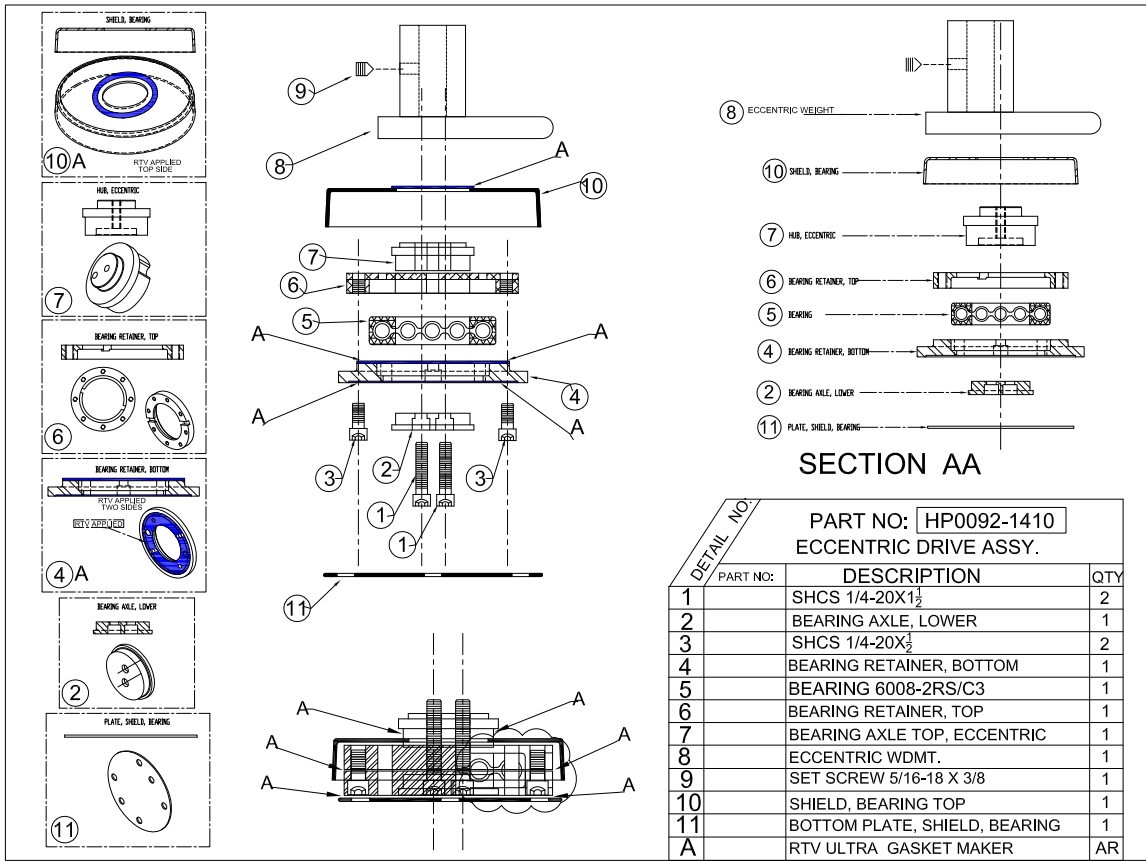

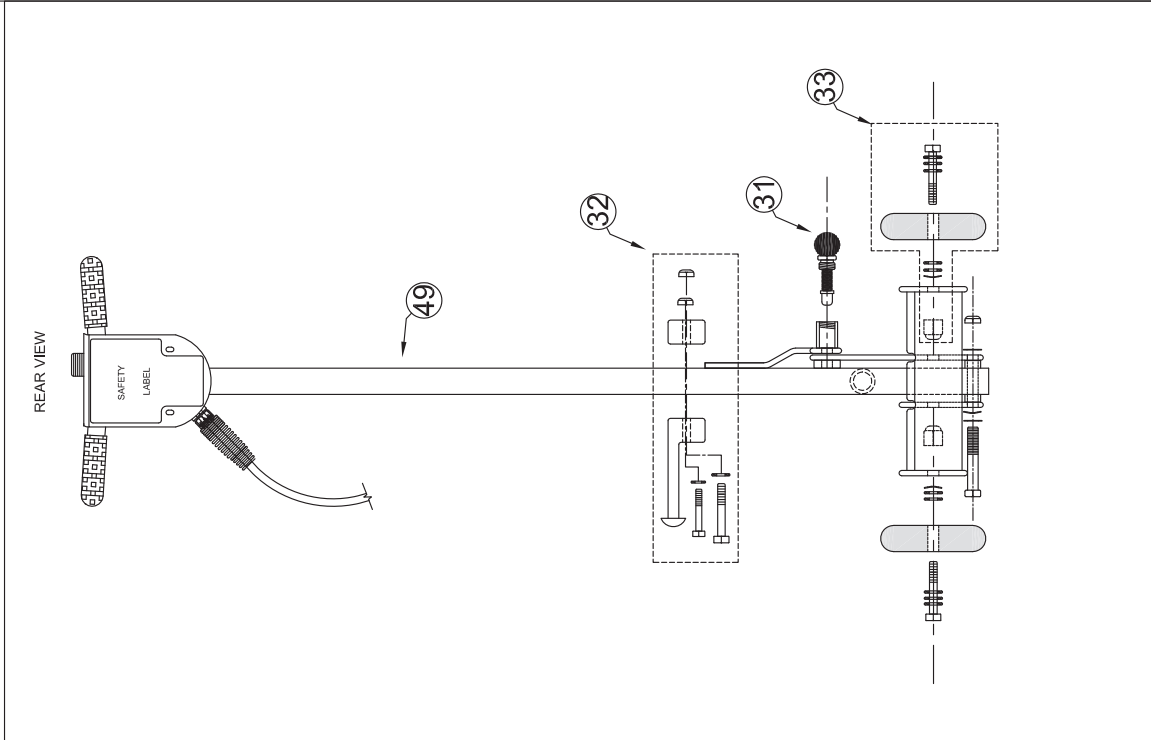
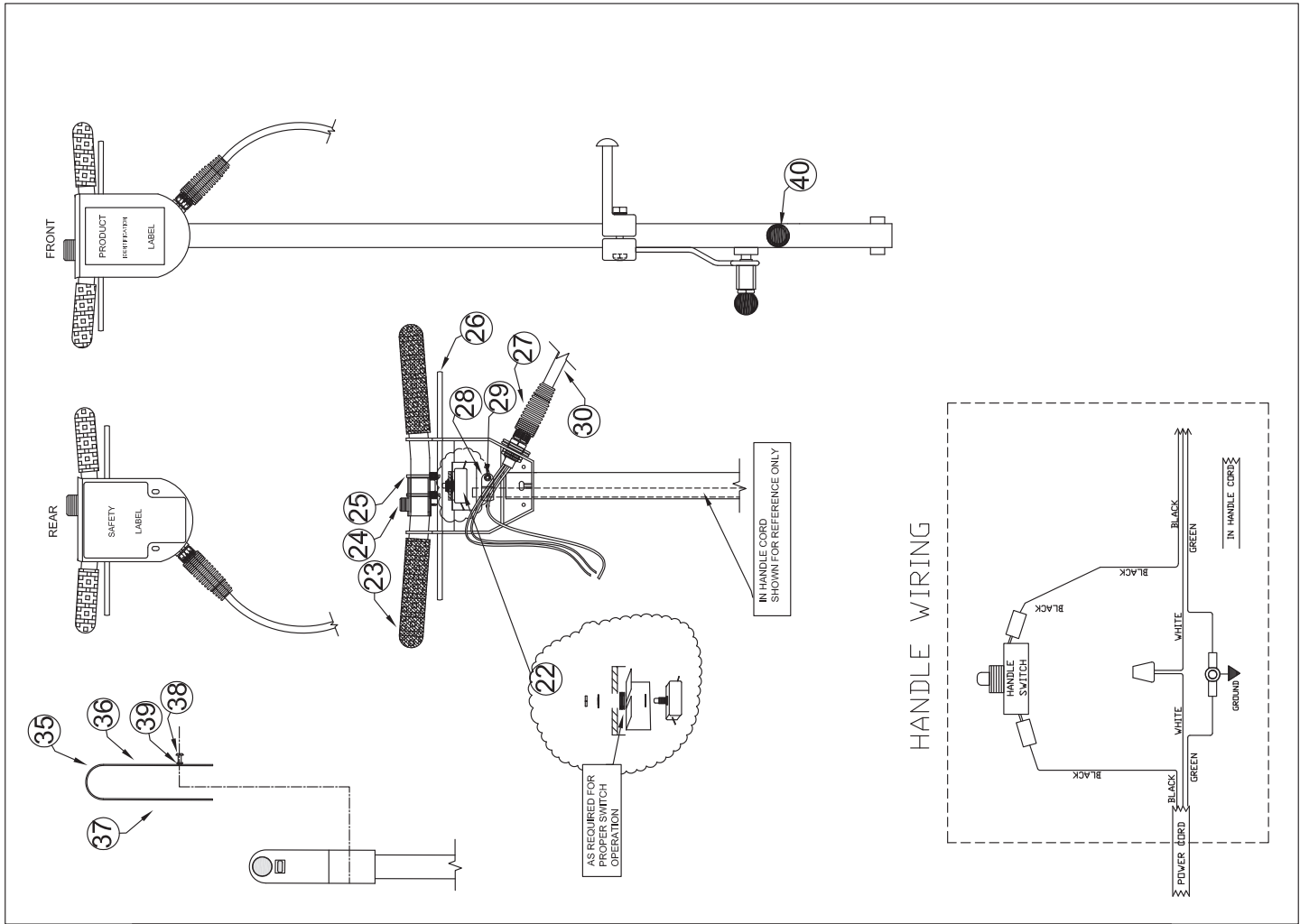

DETAL	PART		
NUMBER	NUMBER	DESCRIPTION	QTY.
1	E0002	MOTOR .5 HP	1
2	W0015P	MAIN FRAME	1
3	H0004	WASHER 3/8 SPLIT RING LOCK ZN	4
4	H0042	BOLT 3/8-16 X 7/8 ZN	4
5	H0075-7	BUTTON BLUG	1
6	H0057	NUT NYLOCK 3/8-16	2
7	W0015-BWT-P	BOTTOM WEIGHT	2
8	H0043	BOLT 3/8-16 X 1-1/2 SHCS ZN	2
9	SM50708	NUT NYLOCK 5/16-18	4
10	H0155	ISOLATOR 1.25	4
11	H0155-1	ISOLATOR CARRIAGE /MAIN FRAME	2
12	H0202	WASHER	2
13	H0025	BOLT	2
14	W0015-CAR-P	CARRIAGE WDMT. BLACK	1
15	H0075-8	BUTTON BLUG 1.25	1
16	H0157	SCREW FHSCS 1/4-20 X 1.125 W/PATCH	4
17	H0158SS	SCREW FHSC 5/16-18 SS	4
18	A1411	PAD DRIVER FACE	1
19	S0056P	PAD DRIVER 1410	1
20	H0003-7	SPACER	4
21	H0174	BOLT TAP 3/8-16 X 2 HEX GR8	2
22	E0007-KIT	SWITCH KIT	1
23	C0007-2	HANDLE GRIP ALTERED	2
24	HP0038	SAFETY SWITCH KIT	1
25	H0012	ROLL PIN	2
26	S0008P	TRIGGER 12 INCH - BLACK	1
27	HP0076	STRAIN RELIEF KIT	1
28	H0065	LOOP CLAMP .312 BLACK	1
29	H0020	SCREW	1
30	E0003-2	POWER CORD 14-3 X 50'	1
31	MERLIN-SPRING KNOB	KNOB ASSY. HANDLE ADJUSTMENT	1
32	HP0095-KIT	CORD HOOK ASSY. KIT SQUARE	1
		CORD HOOK SQUARE BLK.	1
		CORD HOOK CAP BLK.	1
		BOLT 3/8-16 X 2" GR8	2
		WASHER FLAT 3/8 BLK. OXIDE	2
		NUT 3/8-16 NYLOCK FLEX	2
33	HP0096-KIT	WHEEL KIT 1410	2
	CONTAINS PER KIT	WHEEL 5 INCH W/BALL BEARING	1
	CONTAINS PER KIT	WASHER FLAT .875 X .510 X .03 ZN.	5
	CONTAINS PER KIT	WASHER SPRING .515 ID ZN.	1
	CONTAINS PER KIT	BOLT 1/2-13 X 3" GR5 ZN.	1
	CONTAINS PER KIT	NUT 1/2-13 FULL NYLOCK ZN.	1
34	HP0092-1410-KIT	ESSETRIC ASSY 1410 KIT	1
		SHCS 1/4-20 X 1 1/2	2
		BEARING AXLE LOWER	1
		SHCS 1/-20 X 1/2	2
		BEARING RETAINER BOTTOM	1
		BEARING 6008RS/C3	1
		BEARING RETAINER TOP	1
		BEARING AXLE TOP	1
		ECCENTRIC WDMT	1
		SET SCREW 5/16-18 X 3/8	1
		SHIELD BEARING TOP	1

DETAL	PART		
NUMBER	NUMBER	DESCRIPTION	QTY.
		BOTTOM PLATE SHIELD	1
		RTV ULTRA GASKET MAKER	AR
		SCREW 1/4-20 X 1 1/8 W/PATCH	4
35	W0003-3P-COLOR	SWITCH BOX COVER	1
36	L0005-1	SAFETY LABEL	1
37	L0002	SWITCH BOX COVER ID LABEL	1
38	H0002-1	SCREW PHIL 10-24 X 3/4 THREAD FORM ZN	2
39	H0020	LOCK WASHER #10 INT/EXT	2
40	H0028	GROMMET	1
41	A0066-1014	BACKER PAD RED 1410	1
42	HP0097-KIT	VIBRATION ISOLATOR KIT-1410	1
		ISOLATOR 1.25	4
		SPACER	4
		SCREW FHSC 5/16-18 SS	4
		NUT NYLOCK 5/16-18	4
43	HP0098-KIT	MOTOR .5 HP KIT-1410	1
		MOTOR .5 HP	1
		WASHER 3/8 SPLIT RING LOCK ZN	4
		BOLT 3/8-16 X 7/8 ZN	4
44	HP0099-KIT	ISOLATOR CARRIAGE/ MAIN FRAME KIT-1410	1
		ISOLATOR CARRIAGE /MAIN FRAME	2
		WASHER	2
		BOLT	2
45	HP0100-KIT	HANDLE GRIP KIT-1410	1
		HANDLE GRIP ALTERED	2
46	HP0101-KIT	PAD DRIVER W/FACE KIT-1410	1
		PAD DRIVER 1410	1
		PAD DRIVER FACE	1
		SCREW FHSC 5/16-18 SS	4
		SCREW FHSCS 1/4-20 X 1.125 W/PATCH	4
47	HP0076	STRAIN RELIEF KIT	1
		WASHER AND STRAIN RELIEF	2
		STRAIN RELIEF	1
		NUT (APPLETON BL50 OR L 100)	1
48	HP0007-KIT	SWITCH KIT ON/OFF	1
		SWITCH ON/OFF	1
		TOCK WASHER 3/8 INTERNAL TOOTH	1
		WASHER - ZINC PLATED STEEL 3/8	4
		SWITCH INSULATION	1
49	W0002-THSP	HANDLE TIGERHAWK SML	1

LIMITED WARRANTY

Your HAWK equipment which has been manufactured, tested and inspected in accordance with carefully specified engineering requirements, is warranted to be free from defects in material and workmanship. This Limited Warranty is, however, subject to the Following qualifications, conditions and limitations which are set forth to provide you and all users of the HAWK equipment with information concerning the duration, extent, availability, and applicability of this HAWK Limited Warranty, the procedure to be taken to obtain its performance, and other information concerning the **HAWK Limited Warranty policy**.

The HAWK ENTERPRISES Limited Warranty is extended to the original end user as follows:

Motors 1 year parts and 6 months labor

Non-wear items: 1 year parts replacement and 1 year service labor warranty.

Replacement parts guaranteed for 90 days from date of installation against defects in material and workmanship.

This Limited Warranty will not cover damage attributable to the following:

- (1) Improper, unreasonable or negligent use or abuse of the equipment
- (2) Abrasions or punctures of the equipment.

The start date of the Limited Warranty coverage shall be the purchase date of the original end user or six months from the date the machine was shipped from the Factory, whichever comes first.

PARTS OF EQUIPMENT NOT COVERED BY THE LIMITED WARRANTY

Certain parts of equipment require replacement in the ordinary use due to normal wear by reason of their characteristics. Normal wear items such as cords, switches, bumpers, bearings, isolators, compensators, capacitors etc. are excluded from the Limited Warranty.

EXCEPTIONS AND EXCLUSIONS FROM THE LIMITED WARRANTY

This equipment is required to be used on electric current as indicated on the data plate. Otherwise damage, defects, malfunctions or other failure of the equipment arising from use on electric current not as indicated are excepted and excluded from this Limited Warranty. Defects, malfunctions, failure or damage of the equipment caused by improper, unreasonable or neglect use or abuse while in possession of the purchaser are likewise excluded from this warranty. If repair is done on your equipment by anyone other than those designated as authorized to perform such work without first having obtained factory instructions, HAWK ENTERPRISES at its sole option, may determine that this warranty will not apply and that reimbursement for such repair will not be made because of the failure to comply with such factory specified instructions.

PROCEDURE TO BE TAKEN TO OBTAIN PERFORMANCE OF LIMITED WARRANTY REPAIR

To secure repair of the equipment or any warranted parts under this Limited Warranty, the following procedure should be taken. The inoperative equipment or warranted parts, together with satisfactory evidence of the purchase date, must be delivered, with shipping and delivery charges prepaid, to one of the following:

- (1) The dealer from whom purchased;
- (2) Any HAWK distributor's service department in the United States;
- (3) Any HAWK authorized service station in the United States.

If you are unable to locate any of the foregoing, you may write or otherwise communicate with HAWK ENTERPRISES before repair service is performed by anyone else. In such event, HAWK ENTERPRISES will provide either the location or a closely available HAWK distributor service department, or HAWK authorized service station or other factory instructions. Upon compliance with the above procedure, all warranted defects will be repaired, at no additional charge or costs to the customer, and the repaired product returned to the customer, with all shipping and delivery charges pre-paid. In following the procedures set forth, PLEASE MAKE CERTAIN to state the model, type and serial number as shown on the data plate of the equipment.

REPLACEMENT

In the event of a defect, malfunction or failure of your HAWK equipment or any warranted part to conform with this warranty, HAWK may, at its sole option and own expense, replace the equipment or any warranted part with another new, identical or reasonably equivalent model or part in lieu or repairing the defect. **DO NOT** return any equipment or part to the factory without prior authorization.

NO REFUND OF PURCHASE PRICE

HAWK ENTERPRISES **WILL NOT**, as a matter of its Limited Warranty policy, refund the customer's purchase price.

LIMITED WARRANTY REGISTRATION CARD FOR YOUR EQUIPMENT AND REQUEST FOR INFORMATION

Your HAWK distributor from whom you purchased your equipment is responsible for the registration of your Limited Warranty with the factory. Any information or questions you may have concerning your HAWK ENTERPRISES equipment or this Limited Warranty may likewise be secured from the factory. This Limited Warranty will give you specific legal rights, and you may also have other rights which vary from state to state.