

Operator's Manual

Vibratory Rammer

BS50-2, BS50-2i
BS60-2, BS60-2i
BS70-2, BS70-2i
BS65-V

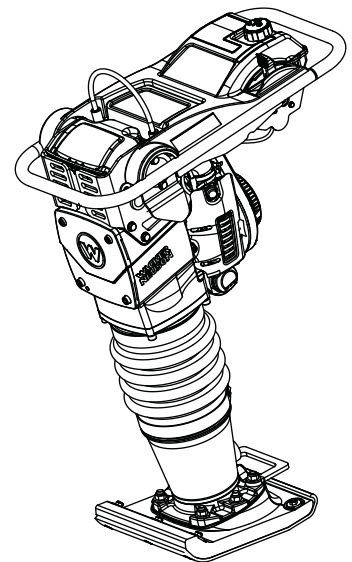

Type	BS50-2, BS50-2i, BS60-2, BS60-2i, BS70-2, BS70-2i, BS65-V
Document	5200016051
Date	1116
Revision	08
Language	EN



Copyright notice

© Copyright 2016 by Wacker Neuson Production Americas LLC

All rights, including copying and distribution rights, are reserved.

This publication may be photocopied by the original purchaser of the machine. Any other type of reproduction is prohibited without express written permission from Wacker Neuson Production Americas LLC.

Any type of reproduction or distribution not authorized by Wacker Neuson Production Americas LLC represents an infringement of valid copyrights. Violators will be prosecuted.

Trademarks

All trademarks referenced in this manual are the property of their respective owners.

Manufacturer

Wacker Neuson Production Americas LLC

N92W15000 Anthony Avenue

Menomonee Falls, WI 53051 U.S.A.

Tel: (262) 255-0500 · Fax: (262) 255-0550 · Tel: (800) 770-0957

www.wackerneuson.com

Original instructions

This Operator's Manual presents the original instructions. The original language of this Operator's Manual is American English.

Foreword

SAVE THESE INSTRUCTIONS—This manual contains important instructions for the machine models below. These instructions have been written expressly by Wacker Neuson Production Americas LLC and must be followed during installation, operation, and maintenance of the machines.

Machine	Item Number
BS 50-2i	5200000642, 5200000643, 5200000657, 5200000658, 5200000659, 5200000660, 5200000661, 5200000687, 5200011099, 5200025428, 5200025429
BS 60-2i	5200000645, 5200000646, 5200000664, 5200000665, 5200000689, 5200000690
BS 70-2i	5200000649, 5200000650, 5200000672, 5200000673

Machine	Item Number
BS 50-2	5200000641, 5200000652, 5200000653, 5200000654, 5200000655, 5200000656, 5200000685, 5200000686
BS 60-2	5200000663, 5200000688, 5200019205
BS 70-2	5200000670, 5200000671

Machine	Item Number
BS 65-V	5200000669

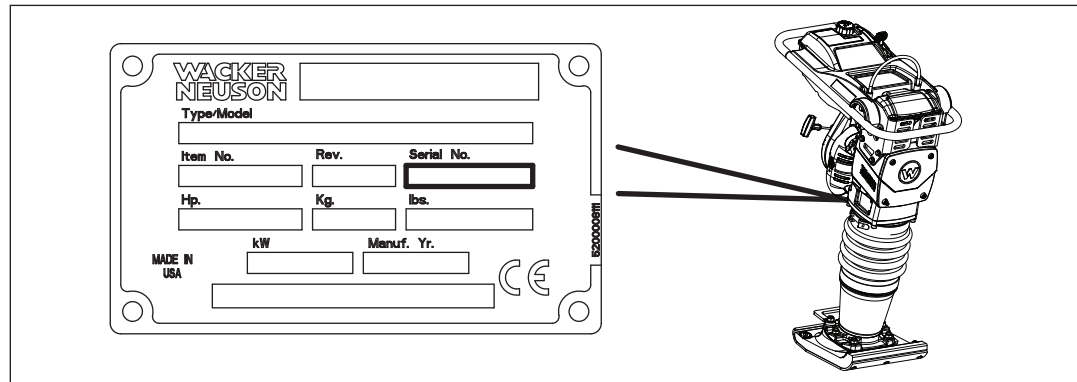

wc_gr010403

Machine identification

A nameplate listing the model number, item number, revision number, and serial number is attached to this machine. The location of the nameplate is shown above.

Serial number (S/N)

For future reference, record the serial number in the space provided below. You will need the serial number when requesting parts or service for this machine.

Serial Number:

Machine documentation

- From this point forward in this documentation, Wacker Neuson Production Americas LLC will be referred to as Wacker Neuson.
- Keep a copy of the Operator's Manual with the machine at all times.
- Use the separate Parts Book supplied with the machine to order replacement parts.
- If you are missing either of these documents, please contact Wacker Neuson to order a replacement or visit www.wackerneuson.com.
- When ordering parts or requesting service information, be prepared to provide the machine model number, item number, revision number, and serial number.

Expectations for information in this manual

- This manual provides information and procedures to safely operate and maintain the above Wacker Neuson model(s). For your own safety and to reduce the risk of injury, carefully read, understand, and observe all instructions described in this manual.
- Wacker Neuson expressly reserves the right to make technical modifications, even without notice, which improve the performance or safety standards of its machines.
- The information contained in this manual is based on machines manufactured up until the time of publication. Wacker Neuson reserves the right to change any portion of this information without notice.
- The illustrations, parts, and procedures in this manual refer to Wacker Neuson factory-installed components. Your machine may vary depending on the requirements of your specific region.

**CALIFORNIA
Proposition
65 Warning**

Combustion exhaust, some of its constituents, and certain vehicle components contain or emit chemicals known to the State of California to cause cancer and birth defects or other reproductive harm.

**Laws
pertaining to
spark
arresters**

NOTICE: State Health Safety Codes and Public Resources Codes specify that in certain locations spark arresters be used on internal combustion engines that use hydrocarbon fuels. A spark arrester is a device designed to prevent accidental discharge of sparks or flames from the engine exhaust. Spark arresters are qualified and rated by the United States Forest Service for this purpose. In order to comply with local laws regarding spark arresters, consult the engine distributor or the local Health and Safety Administrator.

**Manufacturer's
approval**

This manual contains references to *approved* parts, attachments, and modifications. The following definitions apply:

- **Approved parts or attachments** are those either manufactured or provided by Wacker Neuson.
- **Approved modifications** are those performed by an authorized Wacker Neuson service center according to written instructions published by Wacker Neuson.
- **Unapproved parts, attachments, and modifications** are those that do not meet the approved criteria.

Unapproved parts, attachments, or modifications may have the following consequences:

- Serious injury hazards to the operator and persons in the work area
- Permanent damage to the machine which will not be covered under warranty

Contact your Wacker Neuson dealer immediately if you have questions about approved or unapproved parts, attachments, or modifications.

Notes



EC Declaration of Conformity

Manufacturer

Wacker Neuson Production Americas LLC, N92W15000 Anthony Avenue,
Menomonee Falls, Wisconsin 53051 USA

Machine:

Product	BS50-2 BS50-2i
Product category	Vibratory Rammer
Product function	To compact soil
Item number	5200000652, 5200000653, 5200000654, 5200000655, 5200000656, 5200000657, 5200000658, 5200000659, 5200000660, 5200000661, 5200011099, 5100014171, 5100014907, 5100016644, 5100016645, 5100016646, 5100016647, 5100016648, 5100016649, 5100016650
Net installed power	1.7 kW
Measured sound power level	105 dB(A)
Guaranteed sound power level	108 dB(A)

Conformity Assessment Procedure

According to 2000/14/EC ANNEX VIII

Notified Body

Lloyds Register Verification Limited (Notified Body No 0038)
71 Fenchurch Street, London EC3M 4BS, United Kingdom

Directives and Standards

We hereby declare that this product meets and complies with the relevant regulations and requirements of the following directives and standards:

2006/42/EC, 2000/14/EC, 2005/88/EC, 2014/30/EU, EN 500-1, EN 500-4

Authorized Person for Technical Documents

Robert Raethsel, Wacker Neuson Produktion GmbH & Co. KG, Wackerstrasse 6,
85084 Reichertshofen, Germany

Menomonee Falls, WI, USA, 08.07.2016

Keith Herr
Vice President and Managing Director
For Wacker Neuson

Jeff Volden
Director, Product Engineering
For Wacker Neuson

Paul Sina
Manager, Product Engineering
For Wacker Neuson



EC Declaration of Conformity

Manufacturer

Wacker Neuson Production Americas LLC, N92W15000 Anthony Avenue,
Menomonee Falls, Wisconsin 53051 USA

Product

Product	BS60-2 BS60-2i
Product category	Vibratory Rammer
Product function	To compact soil
Item number	5200000663, 5100014847, 5200019205 5200000664, 5200000665, 5100014908
Net installed power	1.8 kW
Measured sound power level	105 dB(A)
Guaranteed sound power level	108 dB(A)

Conformity Assessment Procedure

According to 2000/14/EC ANNEX VIII

Notified Body

Lloyds Register Verification Limited (Notified Body No 0038)
71 Fenchurch Street, London EC3M 4BS, United Kingdom

Directives and Standards

We hereby declare that this product meets and complies with the relevant regulations and requirements of the following directives and standards:

2006/42/EC, 2000/14/EC, 2005/88/EC, 2014/30/EU, EN 500-1, EN 500-4

Authorized Person for Technical Documents

Robert Raethsel, Wacker Neuson Produktion GmbH & Co. KG, Wackerstrasse 6,
85084 Reichertshofen, Germany
Menomonee Falls, WI, USA, 28.07.16

Keith Herr
Vice President and Managing Director
For Wacker Neuson

Jeff Volden
Director, Product Engineering
For Wacker Neuson

Paul Sina
Manager, Product Engineering
For Wacker Neuson



EC Declaration of Conformity

Manufacturer

Wacker Neuson Production Americas LLC, N92W15000 Anthony Avenue,
Menomonee Falls, Wisconsin 53051 USA

Product

Product	BS70-2 BS70-2i
Product category	Vibratory Rammer
Product function	To compact soil
Item number	5200000670, 5200000671, 5100014905, 5100016652 5200000672, 5200000673, 5100014909, 5100016653
Net installed power	2.0 kW
Measured sound power level	105 dB(A)
Guaranteed sound power level	108 dB(A)

Conformity Assessment Procedure

According to 2000/14/EC ANNEX VIII

Notified Body

Lloyds Register Verification Limited (Notified Body No 0038)
71 Fenchurch Street, London EC3M 4BS, United Kingdom

Directives and Standards

We hereby declare that this product meets and complies with the relevant regulations and requirements of the following directives and standards:

2006/42/EC, 2000/14/EC, 2005/88/EC, 2014/30/EU, EN 500-1, EN 500-4

Authorized Person for Technical Documents

Robert Raethsel, Wacker Neuson Produktion GmbH & Co. KG, Wackerstrasse 6,
85084 Reichertshofen, Germany
Menomonee Falls, WI, USA, 13.05.2016

Keith Herr
Vice President and Managing Director
For Wacker Neuson

Jeff Volden
Director, Product Engineering
For Wacker Neuson

Paul Sina
Manager, Product Engineering
For Wacker Neuson



EC Declaration of Conformity

Manufacturer

Wacker Neuson Production Americas LLC, N92W15000 Anthony Avenue,
Menomonee Falls, Wisconsin 53051 USA

Product

Product	BS65-V
Product category	Vibratory Rammer
Product function	To compact soil
Item number	5200000669, 5100016651
Net installed power	2.0 kW
Measured sound power level	104 dB(A)
Guaranteed sound power level	108 dB(A)

Conformity Assessment Procedure

According to 2000/14/EC ANNEX VIII

Notified Body

Lloyds Register Verification Limited (Notified Body No 0038)
71 Fenchurch Street, London EC3M 4BS, United Kingdom

Directives and Standards

We hereby declare that this product meets and complies with the relevant regulations and requirements of the following directives and standards:

2006/42/EC, 2000/14/EC, 2005/88/EC, 2014/30/EU, EN 500-1, EN 500-4

Authorized Person for Technical Documents

Robert Raethsel, Wacker Neuson Produktion GmbH & Co. KG, Wackerstrasse 6,
85084 Reichertshofen, Germany
Menomonee Falls, WI, USA, 13.05.2016

Keith Herr
Vice President and Managing Director
For Wacker Neuson

Jeff Volden
Director, Product Engineering
For Wacker Neuson

Paul Sina
Manager, Product Engineering
For Wacker Neuson

Foreword	3
EC Declaration of Conformity	7
1 Safety Information	17
1.1 Signal Words Used in this Manual	17
1.2 Machine Description and Intended Use	18
1.3 Safety Guidelines for Operating the Machine	19
1.4 Safety Guidelines for Lifting and Transporting the Machine	20
1.5 Service Safety	21
1.6 Operator Safety while Using Internal Combustion Engines	23
2 Labels	24
2.1 Label Locations	24
2.2 Label Meanings	25
3 Lifting and Transporting	30
3.1 Lifting the Rammer	30
3.2 Transporting the Rammer	31
4 Operation	34
4.1 Preparing the Machine for First Use	34
4.2 Recommended Fuel	35
4.3 Refueling the Machine	37
4.4 Filling the Oil Tank	38
4.5 Purging the Oil Lines	39
4.6 Position of the Operator	41
4.7 Before Starting	41
4.8 Starting, Operating, and Stopping the Machine	42
4.9 Emergency Shutdown Procedure	44
4.10 Selecting and Adjusting the Ramming Stroke—BS 65-V	45
4.11 Optional Equipment	48
5 Maintenance	49
5.1 Maintaining the Emission Control System	49
5.2 Periodic Maintenance Schedule	50
5.3 Servicing the Air Cleaner	51

5.4	Checking and Changing the Ramming System Oil	53
5.5	Checking the Fuel Lines and Fittings	55
5.6	Maintaining the Shoe Hardware	56
5.7	Inspecting the Machine	57
5.8	Cleaning the Engine Cooling Fins	58
5.9	Cleaning and Checking the Spark Plug	59
5.10	Inspecting and Cleaning the Fuel Filter	60
5.11	Replacing the In-Line Fuel Filter Assembly	61
5.12	Adjusting the Idle Speed	62
5.13	Long-Term Storage	63
5.14	Machine Disposal / Decommissioning	64
6	Troubleshooting	65
7	Technical Data	66
7.1	BS 50-2i	66
7.2	BS 50-2i Operating Weight	66
7.3	BS 60-2i	67
7.4	BS 60-2i Operating Weight	67
7.5	BS 70-2i	68
7.6	BS 70-2i Operating Weight	68
7.7	BS 50-2	69
7.8	BS 50-2 Operating Weight	69
7.9	BS 60-2	70
7.10	BS 60-2 Operating Weight	70
7.11	BS 70-2	71
7.12	BS 70-2 Operating Weight	71
7.13	BS 65-V	72
7.14	BS 65-V Operating Weight	72
7.15	Sound Measurements	73
7.16	Vibration Measurements	74
7.17	Dimensions—BS 50-2i, BS 50-2	75
7.18	Dimensions—BS 60-2i, BS 60-2, BS 70-2i, BS 70-2, BS 65-V	76
8	Emission Control Systems Information and Warranty—Gasoline	77
8.1	Emission Control System Background Information	77
8.2	Limited Defect Warranty for Wacker Neuson Emission Control Systems	78

1 Safety Information

1.1 Signal Words Used in this Manual

This manual contains DANGER, WARNING, CAUTION, *NOTICE*, and NOTE signal words which must be followed to reduce the possibility of personal injury, damage to the equipment, or improper service.



This is the safety alert symbol. It is used to alert you to potential personal hazards.
▶ Obey all safety messages that follow this symbol.



DANGER

DANGER indicates a hazardous situation which, if not avoided, will result in death or serious injury.

- ▶ To avoid death or serious injury from this type of hazard, obey all safety messages that follow this signal word.
-



WARNING

WARNING indicates a hazardous situation which, if not avoided, could result in death or serious injury.

- ▶ To avoid possible death or serious injury from this type of hazard, obey all safety messages that follow this signal word.
-



CAUTION

CAUTION indicates a hazardous situation which, if not avoided, could result in minor or moderate injury.

- ▶ To avoid possible minor or moderate injury from this type of hazard, obey all safety messages that follow this signal word.
-

NOTICE: Used without the safety alert symbol, NOTICE indicates a situation which, if not avoided, could result in property damage.

Note: A Note contains additional information important to a procedure.

1.2 Machine Description and Intended Use

This machine is a vibratory rammer. The Wacker Neuson Rammer consists of a gasoline or diesel engine, a clutch, a fuel tank, a spring-loaded ramming system, a ramming shoe, and a handle. The engine transmits power through the ramming system and ramming shoe, generating percussive impact force to compact soil. The operator guides and controls the machine from behind using the handle.

This machine is intended to be used for compacting cohesive, mixed, and granular soils in confined areas.

This machine has been designed and built strictly for the intended use described above. Using the machine for any other purpose could permanently damage the machine or seriously injure the operator or other persons in the area. Machine damage caused by misuse is not covered under warranty.

The following are some examples of misuse:

- Using the machine as a ladder, support, or work surface
 - Using the machine to carry or transport passengers or equipment
 - Using the machine as a hammer or for other demolition work
 - Attaching the machine to any other machine
 - Operating the machine outside of factory specifications
 - Operating the machine in a manner inconsistent with all warnings found on the machine and in the Operator's Manual
-

This machine has been designed and built in accordance with the latest global safety standards. It has been carefully engineered to eliminate hazards as far as practicable and to increase operator safety through protective guards and labeling. However, some risks may remain even after protective measures have been taken. They are called residual risks. On this machine, they may include exposure to:

- Heat, noise, exhaust, and carbon monoxide from the engine
- Fire hazards from improper refueling techniques
- Fuel and its fumes
- Personal injury from improper lifting techniques or operating techniques

To protect yourself and others, make sure you thoroughly read and understand the safety information presented in this manual before operating the machine.

1.3 Safety Guidelines for Operating the Machine

Operator training

Before operating the machine:

- Read and understand the operating instructions contained in all manuals delivered with the machine.
- Familiarize yourself with the location and proper use of all controls and safety devices.
- Contact Wacker Neuson for additional training if necessary.

When operating this machine:

- Do not allow improperly trained people to operate the machine. People operating the machine must be familiar with the potential risks and hazards associated with it.

Operator qualifications

Only trained personnel are permitted to start, operate, and shut down the machine. They also must meet the following qualifications:

- have received instruction on how to properly use the machine
- are familiar with required safety devices

The machine must not be accessed or operated by:

- children
- people impaired by alcohol or drugs

Application area

Be aware of the application area.

- Keep unauthorized personnel, children, and pets away from the machine.
- Remain aware of changing positions and the movement of other equipment and personnel in the application area/job site.
- Identify whether special hazards exist in the application area, such as toxic gases or unstable ground conditions, and take appropriate action to eliminate the special hazards before using the machine.

Be aware of the application area.

- Do not operate the machine in areas that contain flammable objects, fuels, or products that produce flammable vapors.

Safety devices, controls, and attachments

Only operate the machine when:

- All safety devices and guards are in place and in working order.
- All controls operate correctly.
- The machine is set up correctly according to the instructions in the Operator's Manual.
- The machine is clean.
- The machine's labels are legible.

To ensure safe operation of the machine:

- Do not operate the machine if any safety devices or guards are missing or inoperative.
- Do not modify or defeat the safety devices.
- Only use accessories or attachments that are approved by Wacker Neuson.

Safe operating practices

When operating this rammer:

- Remain aware of the rammer's moving parts. Keep hands, feet, and loose clothing away from the rammer's moving parts.
- When working near the edges of pits, slopes, trenches, and platforms, always operate the rammer in such a way that there is no possibility of it tipping over or falling in.

When operating this rammer:

- Do not operate a rammer in need of repair.
- Do not tamper with or disable the function of the operating controls.
- Do not leave the rammer running unattended.
- Do not consume the operating fluids used in this machine. Depending on your machine model, these operating fluids may include water, wetting agents, fuel (gasoline, diesel, kerosene, propane, or natural gas), oil, coolant, hydraulic fluid, heat transfer fluid (propylene glycol with additives), battery acid, or grease.

Personal Protective Equipment (PPE)

Wear the following Personal Protective Equipment (PPE) while operating this machine:

- Close-fitting work clothes that do not hinder movement
- Safety glasses with side shields
- Hearing protection
- Safety-toed footwear

After Use

- Stop the engine when the machine is not being operated.
- Close the fuel valve on engines equipped with one when machine is not being operated.
- Ensure that the machine will not tip over, roll, slide, or fall when not being operated.
- Store the machine properly when it is not being used. The machine should be stored in a clean, dry location out of the reach of children.

1.4 Safety Guidelines for Lifting and Transporting the Machine

When lifting the machine:

- Make sure slings, chains, hooks, ramps, jacks, forklifts, cranes, hoists, and any other type of lifting device used is attached securely and has enough weight-bearing capacity to lift or hold the machine safely. See chapter *Technical Data* for machine weight.
- Remain aware of the location of other people when lifting the machine.
- Only use the lifting points and tie-downs described in the Operator's Manual.
- Make sure the transporting vehicle has sufficient load capacity and platform size to safely transport the machine.

To reduce the possibility of injury:

- Do not stand under the machine while it is being lifted or moved.
- Do not get onto the machine while it is being lifted or moved.

1.5 Service Safety

Service training

Before servicing or maintaining the machine:

- Read and understand the instructions contained in all manuals delivered with the machine.
- Familiarize yourself with the location and proper use of all controls and safety devices.
- Only trained personnel shall troubleshoot or repair problems occurring with the machine.
- Contact Wacker Neuson for additional training if necessary.

When servicing or maintaining this machine:

- Do not allow improperly trained people to service or maintain the machine. Personnel servicing or maintaining the machine must be familiar with the associated potential risks and hazards.
-

Precautions

When servicing or maintaining the machine:

- Read and understand the service procedures before performing any service to the machine.
 - All adjustments and repairs must be completed before operating the machine. Do not operate the machine with a known problem or deficiency.
 - All repairs and adjustments shall be completed by a qualified technician.
 - Turn off the machine before performing maintenance or making repairs.
 - Remain aware of the machine's moving parts. Keep hands, feet, and loose clothing away from the machine's moving parts.
 - Re-install the safety devices and guards after repair and maintenance procedures are complete.
-

Machine modifications

When servicing or maintaining the machine:

- Use only accessories/attachments that are approved by Wacker Neuson.

When servicing or maintaining the machine:

- Do not defeat safety devices.
- Do not modify the machine without the express written approval of Wacker Neuson.

Replacing parts and labels

- Replace worn or damaged components.
- Replace all missing and hard-to-read labels.
- When replacing electrical components, use components that are identical in rating and performance to the original components.
- When replacement parts are required for this machine, use only Wacker Neuson replacement parts or those parts equivalent to the original in all types of specifications, such as physical dimensions, type, strength, and material.

Cleaning

When cleaning and servicing the machine:

- Keep the machine clean and free of debris such as leaves, paper, cartons, etc.
- Keep the labels legible.

When cleaning the machine:

- Do not clean the machine while it is running.
- Never use gasoline or other types of fuels or flammable solvents to clean the machine. Fumes from fuels and solvents can become explosive.

Personal Protective Equipment (PPE)

Wear the following Personal Protective Equipment (PPE) while servicing or maintaining this machine:

- Close-fitting work clothes that do not hinder movement
- Safety glasses with side shields
- Hearing protection
- Safety-toed footwear

In addition, before servicing or maintaining the machine:

- Tie back long hair.
- Remove all jewelry (including rings).

Safe service practices

- Do not alter engine speeds. Run the engine only at speeds specified in *Technical Data*.
- Do not operate the machine without an air cleaner.
- Disconnect the spark plug before servicing to avoid accidental start-up.
- Do not crank a flooded engine with the spark plug removed. Fuel trapped in the cylinder will squirt out the spark plug opening.
- Do not test for spark if the engine is flooded or the smell of gasoline is present. A stray spark could ignite the fumes.

1.6 Operator Safety while Using Internal Combustion Engines



WARNING

Internal combustion engines present special hazards during operation and fueling. Failure to follow the warnings and safety standards could result in severe injury or death.

- ▶ Read and follow the warning instructions in the engine owner's manual and the safety guidelines below.



DANGER

Exhaust gas from the engine contains carbon monoxide, a deadly poison. Exposure to carbon monoxide can kill you in minutes.

- ▶ NEVER operate the machine inside an enclosed area, such as a tunnel, unless adequate ventilation is provided through such items as exhaust fans or hoses.

Operating safety

When running the engine:

- Keep the area around the exhaust pipe free of flammable materials.
- Check the fuel lines and the fuel tank for leaks and cracks before starting the engine. Do not run the machine if fuel leaks are present or the fuel lines are loose.

When running the engine:

- Do not smoke while operating the machine.
- Do not run the engine near sparks or open flames.
- Do not touch the engine or muffler while the engine is running or immediately after it has been turned off.
- Do not operate a machine when its fuel cap is loose or missing.
- Do not start the engine if fuel has spilled or a fuel odor is present. Move the machine away from the spill and wipe the machine dry before starting.

Refueling safety

When refueling the engine:

- Clean up any spilled fuel immediately.
- Refill the fuel tank in a well-ventilated area.
- Re-install the fuel tank cap after refueling.
- Do not smoke.
- Do not refuel a hot or running engine.
- Do not refuel the engine near sparks or open flames.
- Use suitable tools for refueling (for example, a fuel hose or a funnel).
- Do not refuel if the machine is positioned in a truck fitted with a plastic bed liner. Static electricity can ignite the fuel or fuel vapors.

2 Labels

2.1 Label Locations

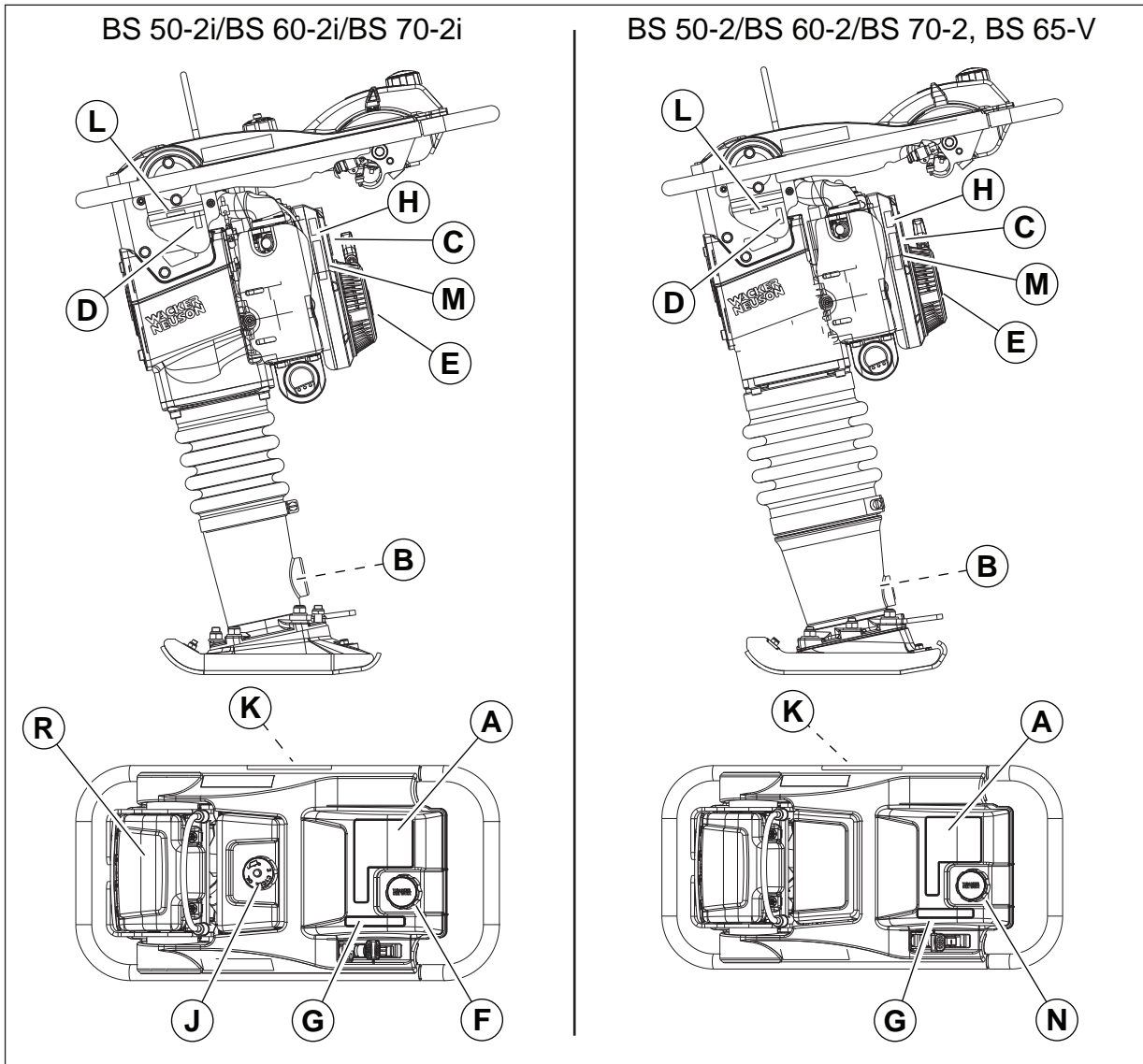

wc_gr010404

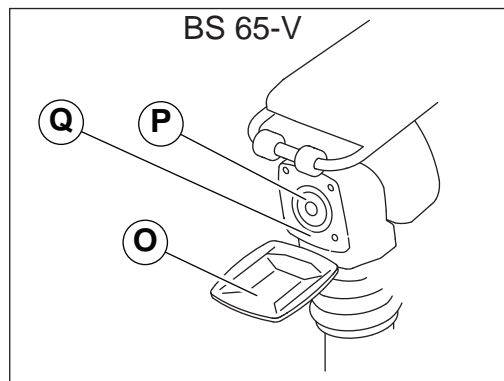





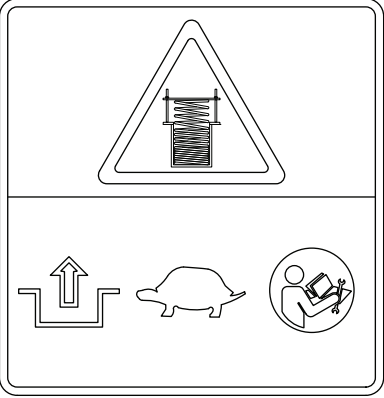
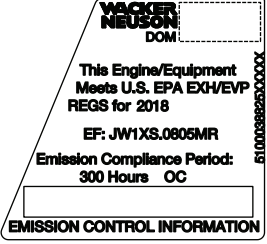
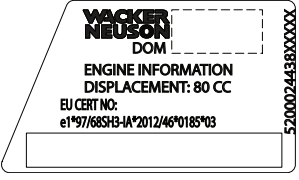
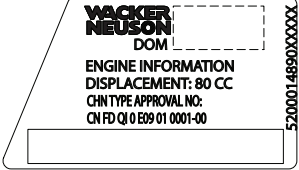

wc_gr011507

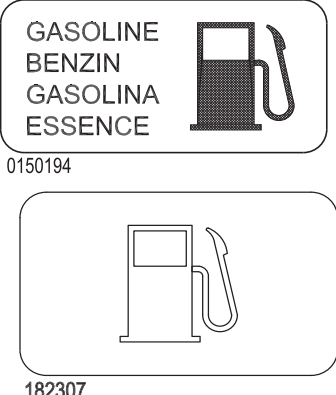
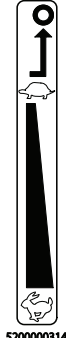
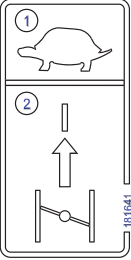

2.2 Label Meanings

<p>A</p>		<p>DANGER Asphyxiation hazard.</p> <ul style="list-style-type: none"> ■ Engines emit carbon monoxide. ■ Do not run the machine indoors or in an enclosed area unless adequate ventilation, through such items as exhaust fans or hoses, is provided. ■ No sparks, flames, or burning objects near the machine. ■ Stop the engine before refueling. <p>WARNING</p> <ul style="list-style-type: none"> ■ To reduce the risk of hearing loss, always wear hearing protection when operating this machine. ■ Read the Operator's Manual. <p>To start the machine:</p> <ol style="list-style-type: none"> 1. Move the throttle to the IDLE position. 2. Push the purge bulb 10 times. 3. Close the choke. 4. Pull the starter rope until engine starts. 5. Move the throttle to the FAST position. <p>To stop the machine:</p> <ol style="list-style-type: none"> 1. Move the throttle past the SLOW position. <p>For optimal control, performance, and minimal hand/arm vibration, grasp the handle as shown.</p>
----------	--	---

<p>B</p>	 <p>118859</p>  <p>178792</p>	<p>WARNING Springs are compressed. Release cover slowly to avoid spring ejection. See the Repair Manual for proper disassembly instructions.</p>
<p>C</p>	  	<p>Emission control information This engine/equipment meets U.S. EPA exhaust/evaporative regulations for 2018. Engine family: JW1XS.0805MR Emission compliance period: 300 hours (heavy use)</p> <p>Engine information Displacement: 80cc This label also includes the EU Certification Number: e1*97/68SH3-IA*2012/46*0185*03</p> <p>Engine information Displacement: 80cc This label also includes CHN Type Approval Number: CN FD Q1 0 E09 01 0001-00</p>

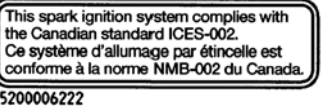
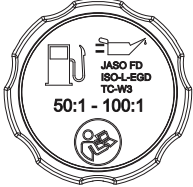
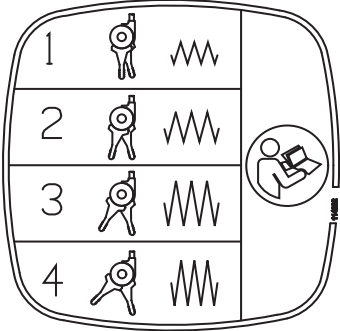
<p>D</p>		<p>Guaranteed sound power level in dB(A)</p>
<p>E</p>		<p>Wacker Neuson label</p>
<p>F</p>		<p>Use only clean, filtered fuel.</p>
<p>G</p>		<p>Turtle = Idle/slow engine speed Rabbit = Full/fast engine speed</p>
<p>H</p>		<ol style="list-style-type: none"> 1. Move the throttle to the IDLE position. 2. Close the choke.

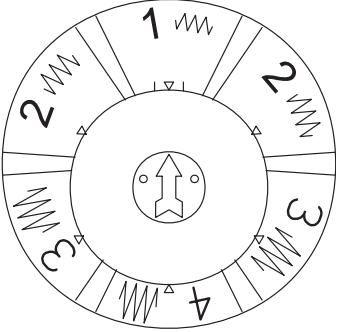
<p>J</p>		<p>Engine oil tank</p> <ul style="list-style-type: none"> ■ Use only Wacker Neuson two-cycle or other fully synthetic oil meeting the NMMA TC-W3, JASO FD, or ISO-L-EGD specification. <p>Read the Operator's Manual.</p>
<p>K</p>		<p>WARNING Operation of this equipment may create sparks that can start fires around dry vegetation. A spark arrester may be required. The operator should contact local fire agencies for laws or regulations relating to fire prevention requirements.</p>
<p>L</p>		<p>This machine may be covered by one or more patents.</p>
<p>M</p>		<p>This spark ignition system complies with the Canadian standard ICES-002.</p>
<p>N</p>		<ul style="list-style-type: none"> ■ Use only Wacker Neuson two-cycle or other fully synthetic oil meeting the NMMA TC-W3, JASO FD, or ISO-L-EGD specification. ■ A gasoline/oil ratio in a range from 50:1 to 100:1 can be used. For optimum engine performance and durability, a 100:1 ratio with a fully synthetic oil meeting the specification described above is preferred.
<p>O</p>	 <p>wc_sy0114282</p>	<p>Adjusting tool label</p> <p>Refer to <i>Selecting Ramming Stroke and Adjusting Ramming Stroke</i> for explanation of this label.</p> <p>Read the Operator's Manual</p>

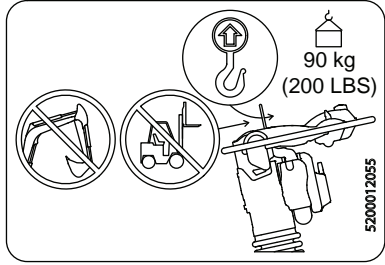
<p>P</p>		<p>Locking lever label</p> <p>Refer to <i>Selecting Ramming Stroke and Adjusting Ramming Stroke</i> for explanation of this label.</p>
<p>Q</p>		<p>CAUTION</p> <p>Cutting hazard. Moving parts under the housing cover can cut skin and catch clothing. Do not operate the machine while the housing cover is open.</p>
<p>R</p>		<p>Lifting the rammer</p> <p>Use proper lifting device (crane or hoist) with proper lifting gear (hooks, slings and/or chains) to lift the rammer.</p> <p>Do not use the end of a boom or a fork lift tine to directly lift a rammer.</p> <p>Only lift the rammer by the lifting cable.</p>

3 Lifting and Transporting

3.1 Lifting the Rammer

- Requirements**
- Lifting device (crane or hoist) capable of supporting the rammer's weight (see the identification plate on the rammer)
 - Lifting gear (hooks, slings, and/or chains) capable of supporting the rammer's weight
 - Engine stopped and cool to the touch

Procedure Perform the procedure below to lift the rammer.

1. Attach the lifting gear to the central lifting cable (**a**).

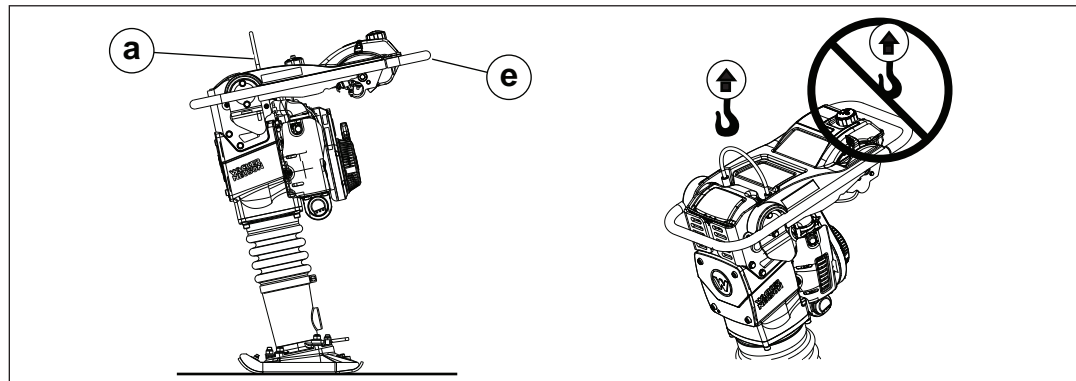

wc_gr010405



WARNING

Crushing hazard. Do not use the guide handle (**e**) to lift the rammer.

- ▶ Use only the central lifting cable to lift the rammer.



WARNING

Crushing hazard. Do not use the central lifting cable if there are any signs of cut wires, excessive wear, or other defects.

- ▶ Always inspect the central lifting cable for wear, damage, or abuse. Replace a damaged lifting cable immediately.
- ▶ Protect the central lifting cable from all sharp edges.

2. Lift the rammer a short distance, making sure that all connections are secure.
3. Continue lifting the rammer as required.

3.2 Transporting the Rammer

Overview This rammer can be transported in a vehicle, or manually, depending on job site conditions and distance to be traveled.

NOTICE: Do not tow this rammer.

Requirements

- Engine stopped and cool to the touch
- Lifting devices and gear
- Fuel tank drained (if transporting horizontally)

Transporting in a vehicle Perform the procedure below to transport the rammer in a vehicle.



WARNING

Lifting injury. This machine is too heavy to lift without mechanical assistance.

- ▶ Do not attempt to lift or carry the rammer without using appropriate lifting devices and gear as described in topic *Lifting the Rammer*.
-

1. Lift the rammer into the transport vehicle. See topic *Lifting the Rammer*.
2. Secure the rammer to the transport vehicle in the upright position to prevent it from tipping, falling, or rolling.

This procedure continues on the next page.

Continued from the previous page.

If the rammer cannot be secured in the upright position,

- a. Drain the fuel tank to prevent fuel from leaking from the cap **(c)**.
- b. Lay the rammer down only as shown and tie it to the vehicle at points **(a)** and **(b)**.

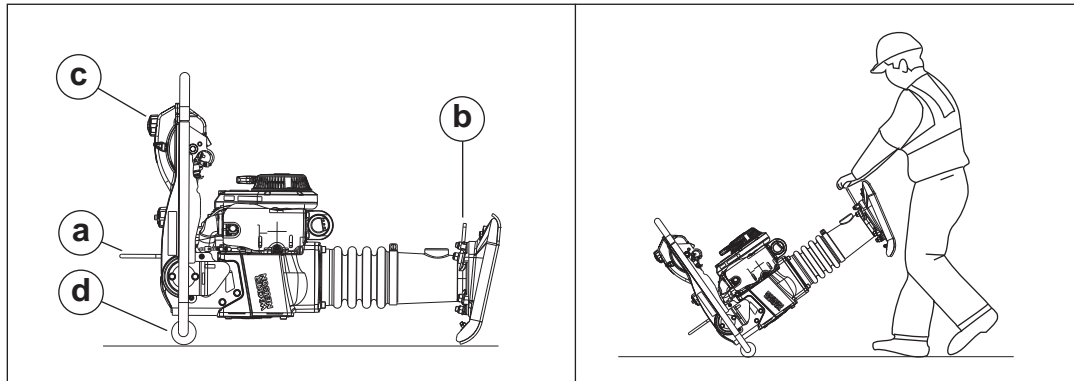

wc_gr010406

Transporting manually

Rollers **(d)** enable the rammer to be rolled from one location to another. Perform the procedure below to transport the rammer manually.

1. Drain the fuel tank to prevent fuel from leaking from the cap.
2. Lay the rammer down as shown.
3. Raise the rammer by the lifting handle **(b)**.
4. Roll the rammer forward or backward as needed.

Notes



4 Operation

4.1 Preparing the Machine for First Use

1. Make sure all loose packaging materials have been removed from the machine.
2. Check the machine and its components for damage. If there is visible damage, do not operate the machine! Contact your Wacker Neuson dealer immediately for assistance.
3. Take inventory of all items included with the machine and verify that all loose components and fasteners are accounted for.
4. Attach component parts not already attached.
5. Add fluids as needed, including fuel, engine oil, and ramming system oil.
6. On rammers with oil injection (BS 50-2i, BS 60-2i, BS 70-2i), visually check the oil in the oil supply line for air bubbles. If air bubbles exist, purge the oil supply line before operating the machine. See topic *Purging the Oil Lines* for detailed instructions.
7. Move the machine to its operating location.

4.2 Recommended Fuel

For rammers with oil injection (BS 50-2i, BS 60-2i, BS 70-2i)

If the rammer has a fuel tank (a) and an oil tank (b), it has oil injection—**No premixing of the gasoline and oil is required.** Mixing of the gasoline and oil is done automatically by the machine.

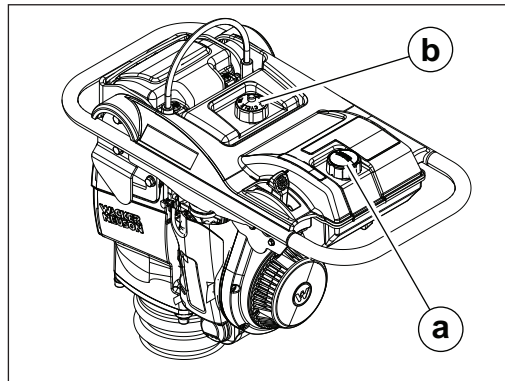

wc qr010452

Fill the fuel tank with regular unleaded gasoline. Fill the oil tank with Wacker Neuson two-cycle oil (or an equivalent). See chapter *Technical Data* for fuel and oil specifications.

Use of oxygenated fuels

Some conventional gasolines are blended with alcohol. These gasolines are collectively referred to as oxygenated fuels. If you use an oxygenated fuel, be sure it is unleaded and meets the minimum octane rating requirement.

Before using an oxygenated fuel, confirm the fuel's contents. Some states and provinces require this information to be posted on the fuel pump.

The following is the Wacker Neuson approved percentage of oxygenates:

ETHANOL - (ethyl or grain alcohol) 10% by volume. You may use gasoline containing up to 10% ethanol by volume (commonly referred to as E10). Gasoline containing more than 10% ethanol (such as E15, E20, or E85) may not be used because it could damage the engine.

If you notice any undesirable operating symptoms, try another service station, or switch to another brand of gasoline.

Fuel system damage or performance problems resulting from the use of an oxygenated fuel containing more than the percentages of oxygenates mentioned above are not covered under warranty.

**For rammers without oil injection
(BS 50-2, BS 60-2, BS 70-2, BS 65-V, BS 65-V)**

If the rammer has a fuel tank (c) but no oil tank, the engine **requires a two-cycle gasoline/oil mixture.**

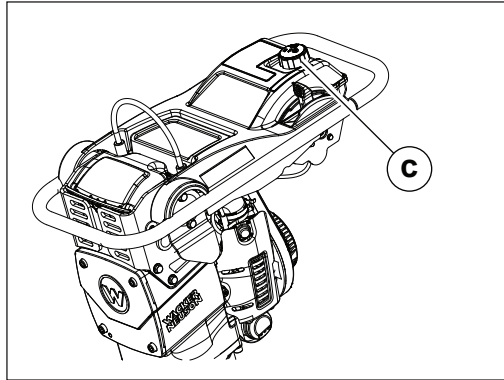

wc_gr011466

NOTICE: Use only the recommended gasoline/oil mixture to fuel this machine. Using gasoline alone will severely damage the engine.

Requirements

- Use only Wacker Neuson two-cycle or other fully synthetic oil meeting the NMMA TC-W3, JASO FD, or ISO-L-EGD specification.
- A gasoline/oil ratio in a range from 50:1 to 100:1 can be used. For optimum engine performance and durability, a 100:1 ratio with a fully synthetic oil meeting the specification described above is preferred.
- Mix regular unleaded gasoline and two-cycle engine oil in a separate container before filling the tank.
- Refer to the chart below for the proper quantities to use when mixing gasoline and oil.

FUEL RATIO 50:1				FUEL RATIO 100:1			
Gasoline	Oil	Gasoline	Oil	Gasoline	Oil	Gasoline	Oil
5 liters	100 ml	1 gallon	2.5 oz.	5 liters	50 ml	1 gallon	1.25 oz.
10 liters	200 ml	3 gallons	8.0 oz.	10 liters	100 ml	3 gallons	4.0 oz.
15 liters	300 ml	5 gallons	13.0 oz.	15 liters	150 ml	5 gallons	6.5 oz.

4.3 Refueling the Machine

- Requirements**
- Machine shut down
 - Engine cool
 - Machine standing upright on the ramming shoe
 - Fresh, clean fuel supply

Procedure Perform the procedure below to refuel the machine.



WARNING

Fire and burn hazard. Fuel and its vapors are extremely flammable.

- ▶ Keep all sources of ignition away from the machine while refueling.
- ▶ Do not refuel if the machine is positioned in a truck fitted with a plastic bed liner. Static electricity can ignite the fuel or fuel vapors.
- ▶ Refuel only when the machine is outdoors.
- ▶ Clean up spilled fuel immediately.

1. Remove the fuel cap (a).

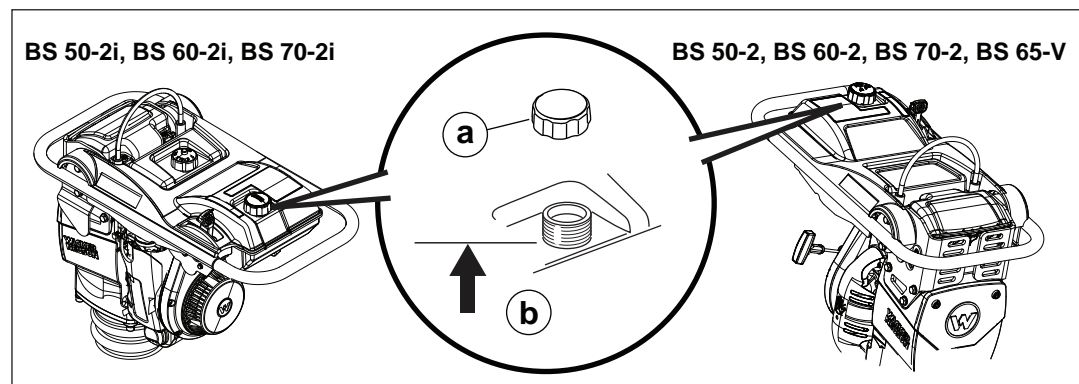

wc_gr011467

2. Fill the fuel tank up to the base of the neck (b).



CAUTION

Fire and health hazard. Fuel expands when heated. Expanding fuel in an over-filled tank can lead to spills and leaks.

- ▶ Do not overfill the fuel tank.

3. Re-install the fuel cap.

Result The machine has now been refueled.

4.4 Filling the Oil Tank

For rammers with oil injection (BS 50-2i, BS 60-2i, BS 70-2i)

If the rammer has a fuel tank (a) and an oil tank (b), it has oil injection. The oil tank requires oil.

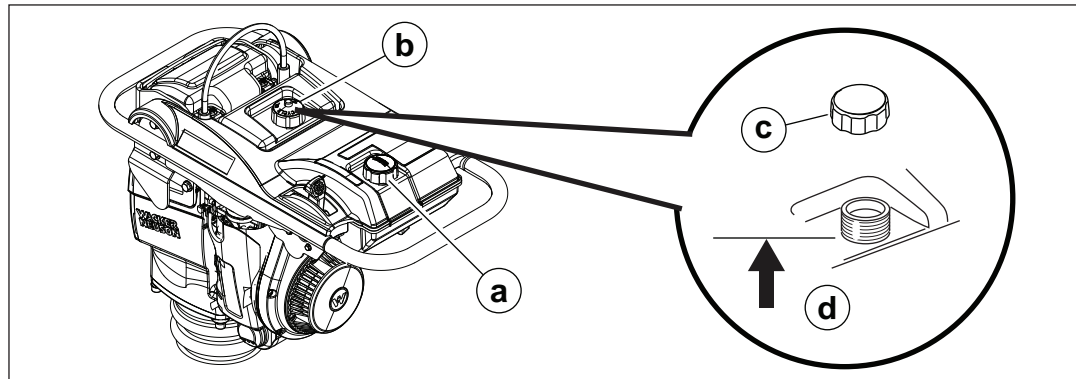

wc_gr011417

- Requirements**
- Machine shut down
 - Engine cool
 - Machine standing upright on the ramming shoe
 - Wacker Neuson 2-cycle or equivalent oil

- Procedure**
- Perform the procedure below to fill the oil tank.
1. Remove the oil tank cap (c). Fill the oil tank up to the base of the neck (d).
 2. Re-install the oil tank cap.
- Note:** Clean up any spilled oil.

Result The oil tank has now been filled.

4.5 Purging the Oil Lines

For rammers with oil injection (BS 50-2i, BS 60-2i, BS 70-2i)

If the rammer has a fuel tank (a) and an oil tank (b), it has oil injection. The oil lines may need purging.

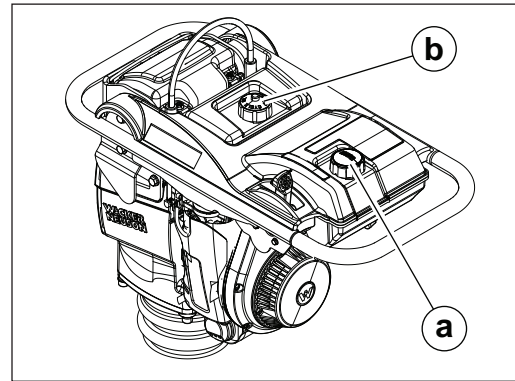

wc_gr010452

When As needed: when air bubbles are visible in the oil supply line or discharge line

- Requirements**
- Machine is stopped
 - Engine is cool to the touch
 - Oil tank is filled
 - Fresh oil (as specified in *Technical Data*)
 - Phillips screwdriver
 - Plastic syringe
 - Clean, dry, absorbent cloth or paper towels

Purging the oil supply line Perform the procedure below to purge the oil supply line.

1. Locate the oil supply line (x) connected to the oil pump (y).

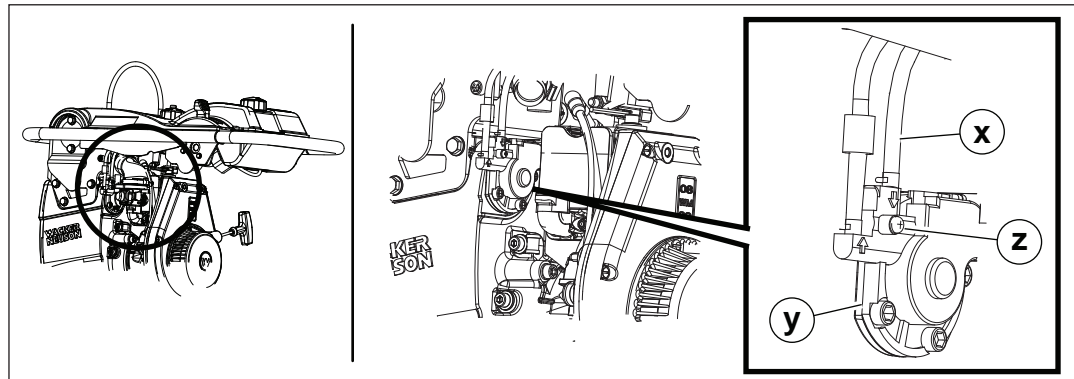

wc_gr011479

2. Loosen (open), but do not remove, the bleed screw (z). Gravity in the oil supply line will purge trapped air.
3. When air bubbles are no longer visible in the oil supply line, retighten the bleed screw.
4. Wipe residual oil from the supply line and oil pump.

This procedure continues on the next page.

Continued from the previous page.

Purging the oil discharge line

Perform the procedure below to purge the oil discharge line.

1. Locate the oil discharge line **(c)**.

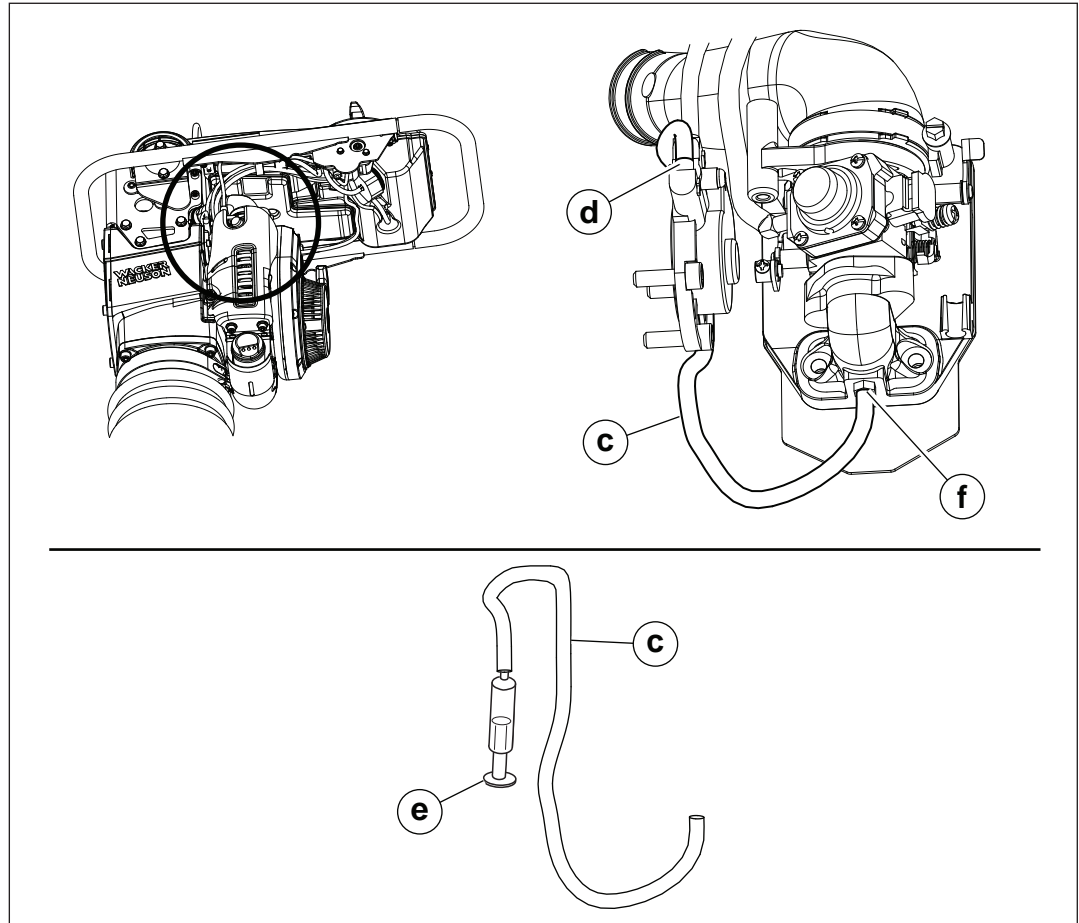

wc_gr012472

2. If air bubbles are visible in the oil discharge line, they must be manually purged using the following method:

Disconnect the oil discharge line at the oil pump **(d)**. Using a plastic syringe **(e)** filled with oil, inject oil into the oil discharge line until the air bubbles are gone and oil is visible up to the carburetor adapter fitting **(f)**.

3. After the air bubbles have been purged, reconnect the oil discharge line. Make sure that the connections are tight with no oil leaks.
4. Wipe residual oil from the oil discharge line and fittings.

Result

The oil lines have been purged.

4.6 Position of the Operator

For optimal control, performance, and minimal hand/arm vibration, follow the guidelines below when using the machine.

Grasp the handle with both hands as shown.

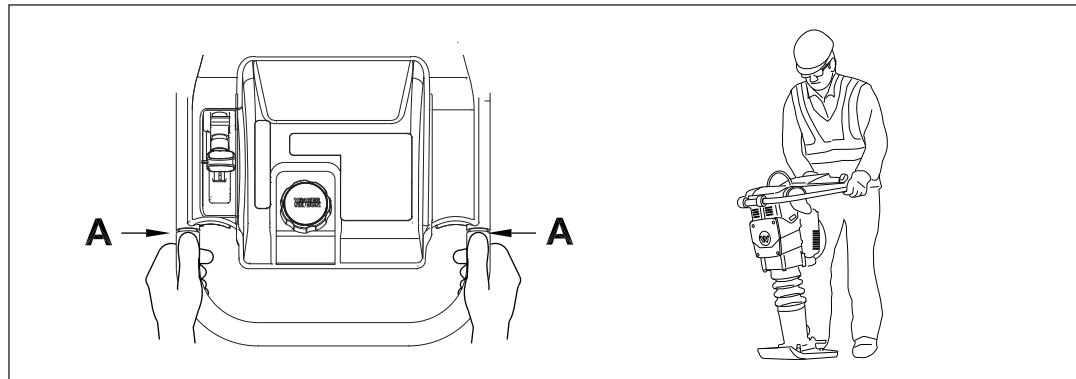

wc_gr011468

Stand behind the rammer, walking slowly and guiding the direction of travel as the machine moves forward.

Note: *Hand/Arm Vibration (HAV) has been optimized for the hand position shown. Reported HAV levels are measured at position A in conformance with EN 1033 and ISO 5349 standards.*

4.7 Before Starting

1. Read safety instructions at the beginning of this manual.
2. Make sure that the fuel tank is full.
3. On machines with oil tanks:
 - ▶ Make sure the oil tank is at least ¼ full.
 - ▶ Check the oil lines for air.
4. Check the fuel lines and fittings.
5. Check the air filter.
6. Check the ramming system oil level.
7. Place the rammer on loose soil or gravel. **DO NOT** start the rammer on hard surfaces such as asphalt or concrete.

4.8 Starting, Operating, and Stopping the Machine

- Requirements**
- Rammer is in serviceable condition and has been properly maintained
 - There is fuel in the tank

Starting the machine

Perform the procedure below to start the machine.

1. Move the throttle to the idle position (**c2**). This will automatically start the flow of fuel.

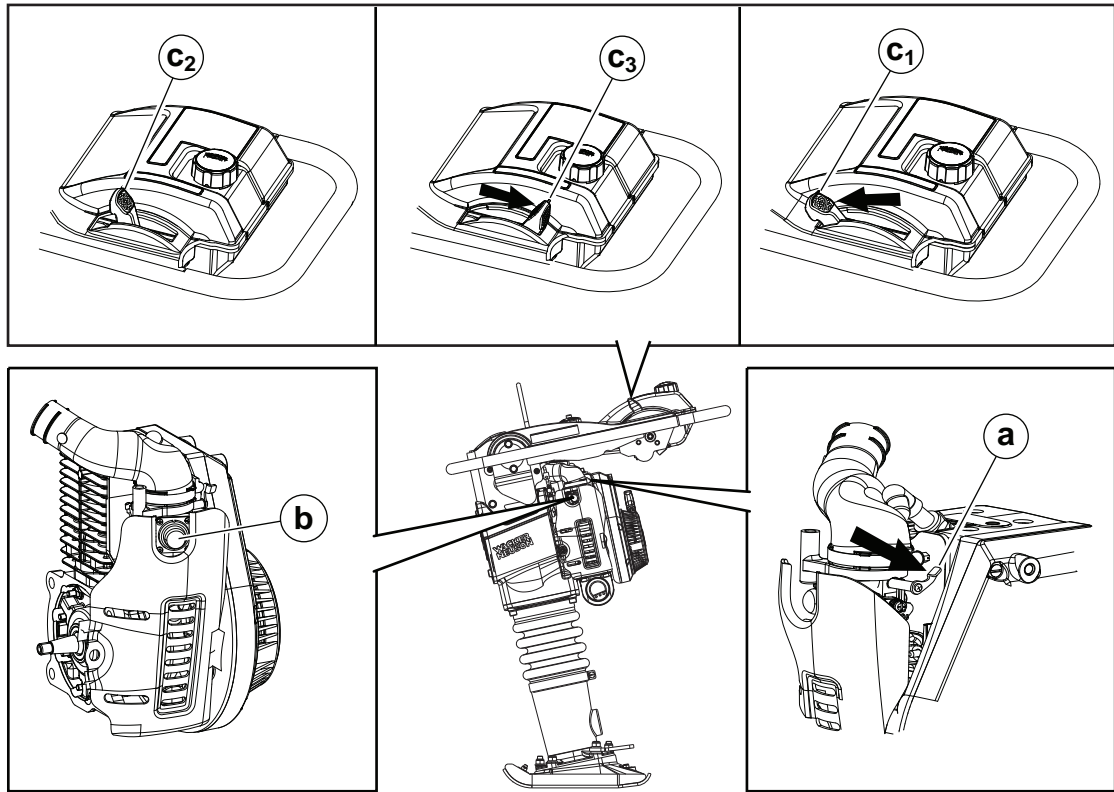

wc_gr011422

2. Close the choke (**a**).
3. Pump the purge bulb (**b**) 6 to 10 times or until you see fuel in the bulb.

Note: The engine will not become flooded by pumping the purge bulb more than 10 times. Pumping the purge bulb removes air from the fuel system. It does not pump fuel into the carburetor.

4. Pull the starter rope repeatedly until the engine starts.
- Multiple pulls of the starter rope (usually fewer than five) may be required to start an engine:
- on a new machine being operated for the first time
 - that has not been run for a long period of time (a week or more)
 - that has been run completely out of fuel
 - in cold weather conditions

This procedure continues on the next page.

Continued from the previous page.

Operating the machine

Perform the procedure below to operate the rammer.

1. Move the throttle to the full position **(c3)**. The choke will open automatically.
2. Guide the rammer's direction of travel. Allow the rammer to pull itself forward. Do not try to overpower the rammer.



CAUTION

Do not lift or move the rammer to another location while it is operating. You may lose control of it.

- ▶ Stop the engine before lifting or moving the rammer to another location.
- ▶ Restart the engine only after the rammer is in place.

Safe operating practices

- For best compaction and shoe wear, the shoe must hit the ground flat **(d)**, not on its toe or heel.

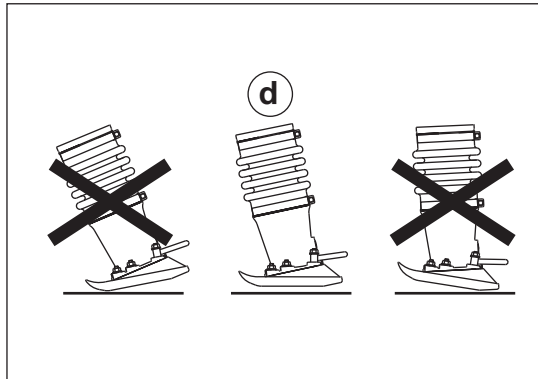

wc_gr008978

- Guide the rammer in such a way that you are not squeezed between the rammer and solid objects.
- Make sure you have solid footing when operating the rammer on uneven ground or when compacting coarse material.

Stopping the machine

1. Place the throttle in the idle position **(c2)**.
2. Shut off the engine by moving the throttle through the detent to the off position **(c1)**. The engine will stop and the fuel valve will close.

4.9 Emergency Shutdown Procedure

Procedure If a breakdown or accident occurs while the machine is operating, follow the procedure below:

1. Reduce engine speed to idle.
2. Stop the engine.
3. Close the fuel valve.
4. Contact the rental yard or machine owner for further instructions.

4.10 Selecting and Adjusting the Ramming Stroke—BS 65-V

Overview The length of the ramming stroke directly affects the impact force delivered by the rammer. Selecting the appropriate stroke depends on job requirements and soil conditions.

The ramming stroke is adjusted by rotating a locking lever inside the housing.



WARNING

Personal injury hazards.

- ▶ Observe the safety requirements described below when adjusting the ramming stroke.

Safety requirements

To avoid injuring yourself and others:

- Always stop the engine before adjusting the ramming stroke. The clutch could engage, causing the rammer to jump unexpectedly.
- Adjust the ramming stroke with machine standing upright and resting on a firm, level surface.
- Do not adjust the ramming stroke if the machine is in an unstable position where it can easily tip or slide.
- Adjustment should be performed by one person and with no one else near the machine. The tool used to make the adjustment could slip out of your hands and strike someone standing nearby.
- Do not operate the rammer with the stroke adjusting cover open. The locking lever rotates rapidly and could catch on skin or clothing.

Location

The locking lever (a) is located inside the housing. The removable adjusting tool (b) fits into the bore (c) on the locking lever.

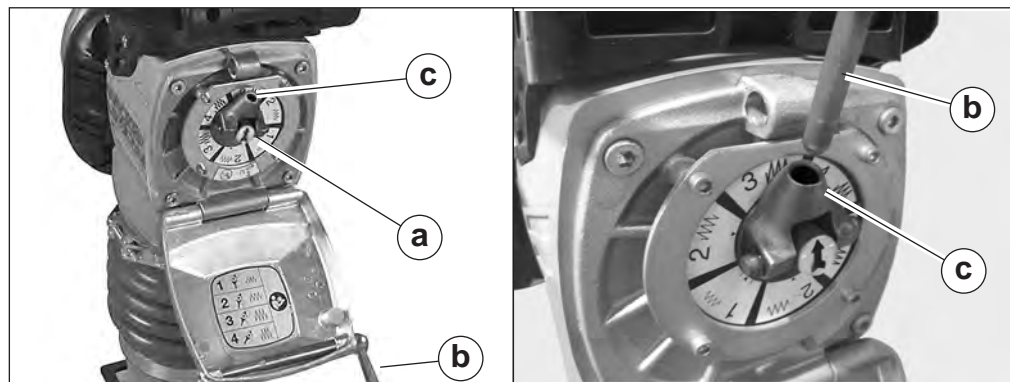

wc_gr008955

This procedure continues on the next page.

Continued from the previous page.

Adjusting the ramming stroke

Perform the procedure below to adjust the ramming stroke.

1. Remove the adjusting tool **(b)** from the housing cover. Open the housing cover.

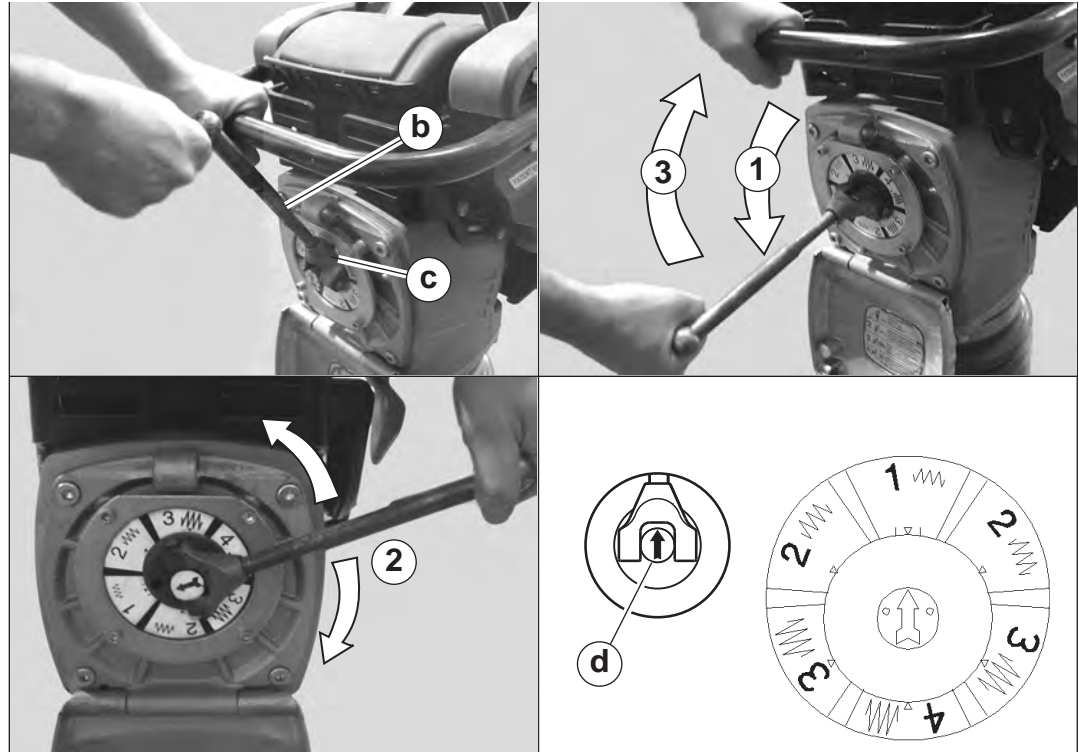

wc_gr008956

2. Verify that the arrow **(d)** at the center of the locking lever is pointing up.



WARNING

Crushing hazard. If the arrow is pointing down, the spring system is not balanced. The top half of the rammer could drop unexpectedly while making the stroke adjustment.

- If the arrow is pointing down, balance the spring system as described below.

To balance the spring system, stand behind the rammer and use the guide handle to rock the machine back and forth until you feel the spring system relax. The arrow should now be facing up.

3. Steady the rammer by holding the guide handle. Insert the adjusting tool **(b)** into the bore **(c)**. Make sure it is fully seated and will not slip out. Using the adjusting tool for leverage, push the locking lever straight down until it is completely disengaged. (Refer to Operation 1 in the illustration.)
4. Using the adjusting tool, rotate the locking lever until the center arrow points to the desired stroke setting (Operation 2).

Note: *There are two positions for stroke settings 2 and 3. Either position can be selected—the result will be the same.*

This procedure continues on the next page.

Continued from the previous page.

Note: Choosing a stroke setting applies tension to the spring system. This tension will release as the locking lever is returned back to its locked position. When this happens, the rammer will settle, causing the handle and crankcase to drop down. The movement is slight but happens quickly. Be aware of this when moving the locking lever.

5. Push or pull the adjusting tool to move the locking lever back to its locked position (Operation 3). When the locking lever is halfway between the locked and unlocked position, the spring system will settle and move as described in the warning above.
6. Remove the adjusting tool. Close the housing cover and lock it in place with the adjusting tool.

Result

The ramming stroke has now been selected. Operate the machine at the corresponding throttle setting as shown on the chart below.

Selecting the ramming stroke

The label located inside the housing cover indicates the general compaction application, together with approximate throttle settings and impact levels for each stroke level. It should be used as a general guide when selecting the appropriate ramming stroke.

Summary of Stroke and Throttle Settings				
Stroke Setting	Throttle Position	Percussion Blows/Min.	Stroke at Ramming Shoe mm (in.)	Applications
1	1/4–1/2	750	up to 25 (1)	smoothing
2	1/2–3/4	650	up to 65 (2.6)	normal compaction
3	3/4–full load	650	up to 75 (3)	heavy compaction
4	full load	600	up to 80 (3.2)	wet and cohesive soils; not for hard soils which are difficult to compact

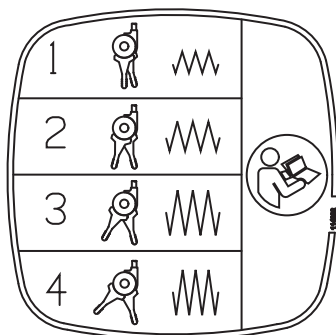

wc_sy0114282

4.11 Optional Equipment

The following optional equipment is available:

- Foot extensions **(a)**—a narrow rammer foot for use in compacting trenches and in areas of limited clearance. Available sizes are 102 mm x 102 mm (4 in. x 4 in.) and 102 mm x 309 mm (4 in. x 12 in.).
- Wheel kit **(b)**—solid rubber tires joined to a steel axle, attached to the lifting handle by means of a slip-on retaining plate.

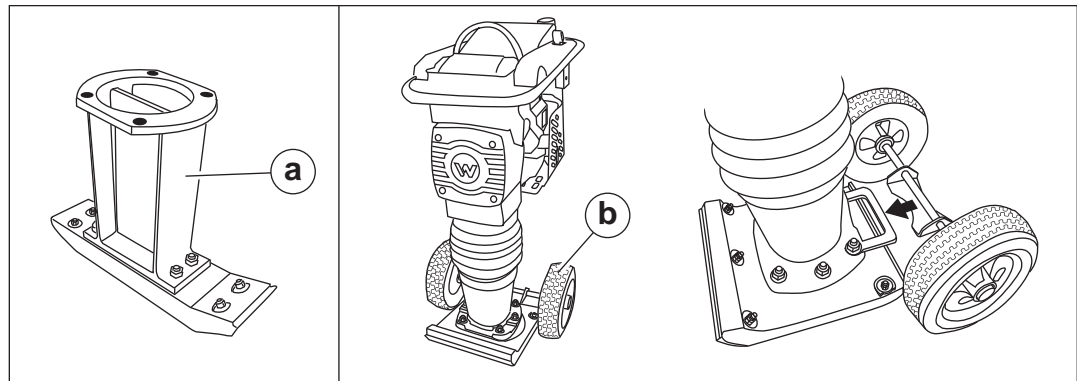

wc_gr008992

Contact your Wacker Neuson dealer for ordering information.

5 Maintenance



WARNING

A poorly maintained machine can malfunction, causing injuries or permanent damage to the machine.

- ▶ Keep the machine in safe operating condition by performing periodic maintenance and making repairs as needed.
-

5.1 Maintaining the Emission Control System

For machines sold in North America:

Normal maintenance, replacement, or repair of emission control devices and systems may be performed by any repair establishment or individual; however, warranty repairs must be performed by a dealer/service center authorized by Wacker Neuson. The use of service parts that are not equivalent in performance and durability to authorized parts may impair the effectiveness of the emission control system and may have a bearing on the outcome of a warranty claim.

5.2 Periodic Maintenance Schedule

The table below lists basic machine maintenance. Tasks designated with check marks may be performed by the operator. Tasks designated with square bullet points require special training and equipment.

	Daily before starting	After first 5 hours	Every week or 25 hours	Every 3 months or 300 hours	Every 5 months or 500 hours	Every year
Check air filter. Replace air filter as needed.	✓					
Check ramming system oil level in sightglass.	✓					
Check fuel line and fittings for cracks or leaks. Replace as needed.	■					
Tighten ramming shoe hardware.		■	■			
Inspect the machine.		✓	✓			
Clean engine cooling fins.			✓			
Clean and check spark plug gap.			■			
Change ramming system oil. ¹				■		
Inspect central lifting cable for wear, damage, or abuse.				✓		
Replace in-line fuel filter assembly.					■	
Replace spark plug.						■
Inspect and clean in-tank fuel filter.						✓

¹Change ramming system oil after first 50 hours of operation.

5.3 Servicing the Air Cleaner

When Inspect the air filter daily. Replace filter elements as needed.

- Requirements**
- Engine stopped and cool to the touch
 - Replacement filter elements (as needed)
 - Mild detergent
 - Warm water
 - Compressed air

NOTICE: Do not run the engine without the main paper air filter **(b)**. Severe engine damage will occur.



WARNING

Explosion and fire hazards.

- ▶ Never use gasoline or other types of low flash point solvents for cleaning the air filter. Use only compressed air, mild detergent, and warm water.

Procedure Perform the procedure below to clean the filter elements.

1. Remove the air cleaner cover **(a)**.

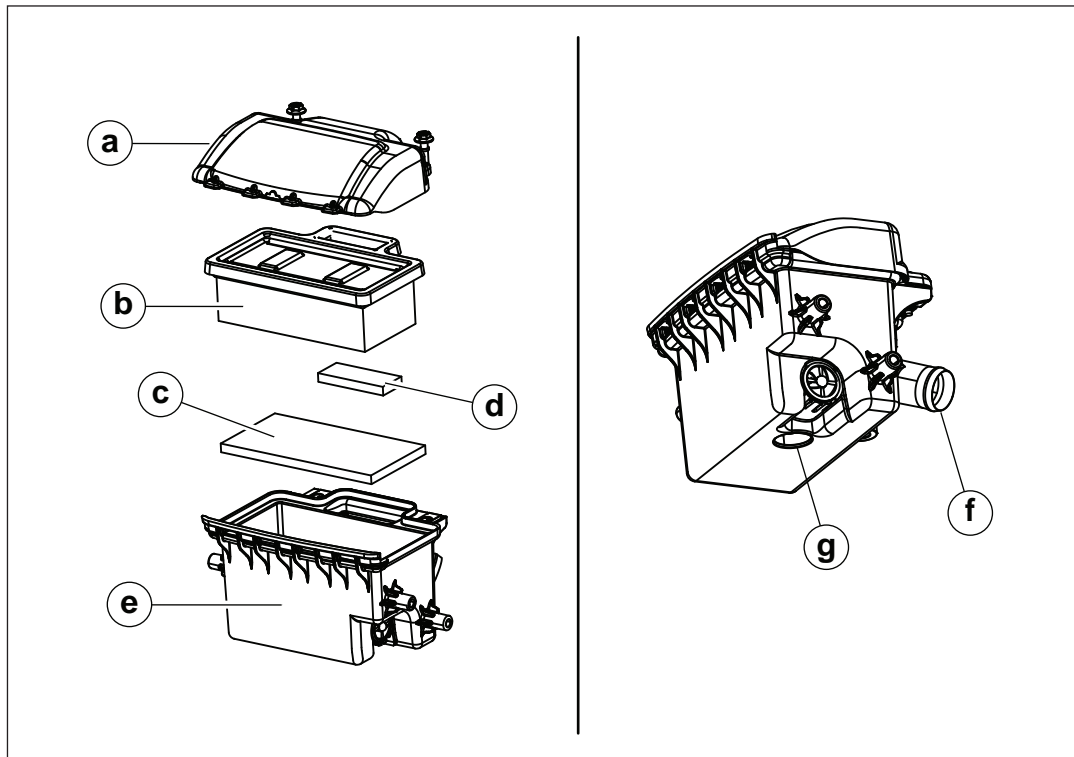

wc_gr011512

This procedure continues on the next page.

Continued from the previous page.

2. Remove the main paper filter element **(b)**, foam prefilter **(c)**, and foam discharge filter **(d)** and inspect them for holes or tears. Replace the element and filters if they are damaged.
3. Replace the main paper filter element **(b)** if it appears heavily soiled.
4. Clean the foam prefilter and foam discharge filter **(c, d)** with low-pressure compressed air. If the filters are extremely soiled, wash them in a solution of mild detergent and warm water. Rinse the filters thoroughly in clean water. Allow them to dry thoroughly before re-installing.

Note: *Do not oil the foam prefilter or the foam discharge filter.*

5. Wipe out the filter housing **(e)** with a clean cloth. Do not use compressed air.

NOTICE: Do not allow dirt to get into the engine intake port **(f)** while cleaning. Damage to engine will result.

6. Check that the precleaner debris ejector port **(g)** is clear.
-

Result

The air cleaner has now been serviced.

5.4 Checking and Changing the Ramming System Oil

Background Lubricating oil is distributed throughout the ramming system by the vibrating action of the rammer. Holes drilled in the piston carry oil from the bottom of the rammer to the crankcase as the rammer operates. Oil in the ramming system must be maintained at the correct level to ensure that the ramming system operates efficiently.

Checking the oil level

Perform the following procedure to check the ramming system oil level.

Note: *If the rammer has been transported in the horizontal position or has recently been used, place it upright and allow it to stand in the upright position for 15 minutes before checking the oil level. This will allow the oil to settle and provide a more accurate reading.*

1. Tip the rammer so that it is perpendicular with the ground.

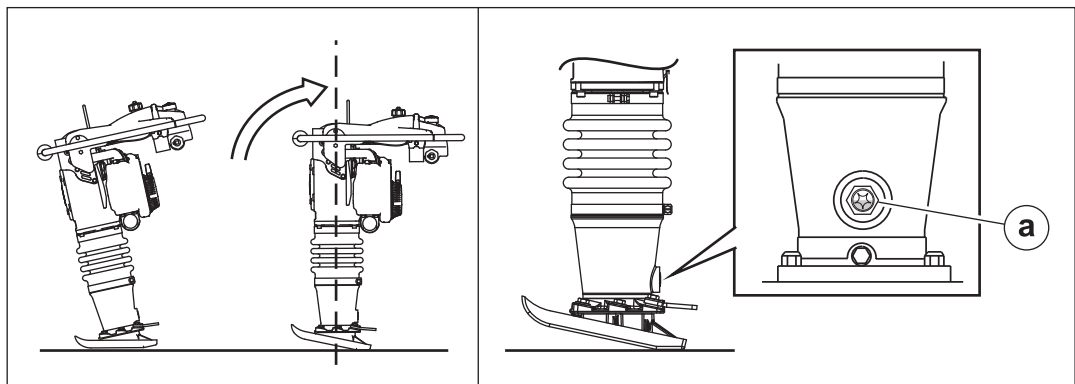

wc_gr007389

2. Check the oil through the sightglass (a).
The correct oil level will fill 1/2 to 3/4 of the sightglass. Add more oil if necessary.

Adding oil

Perform the following procedure to add oil to the ramming system.

NOTICE: Do not overfill the ramming system with oil. Excessively high levels of oil can create a hydraulic lock in the ramming system. This can result in erratic operation and cause damage to the engine clutch, the ramming system, and the shoe.

1. Tip the rammer forward to allow access to the sightglass. Secure the rammer in this position.

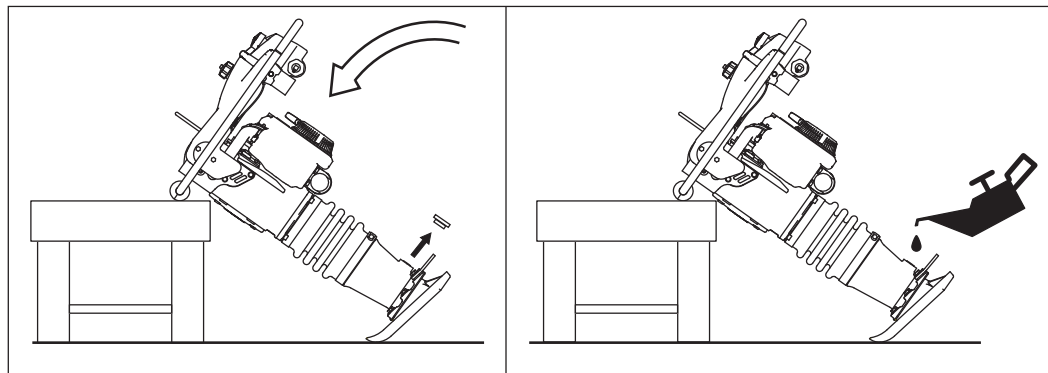

wc_gr007401

This procedure continues on the next page.

Continued from the previous page.

2. Remove the sightglass. Clean the threads of the sightglass, then wrap the threads with Teflon tape.
3. Add oil to the machine through the sightglass opening in the housing.
4. Re-install the sightglass, but do not torque it at this time.
5. Stand the machine upright and check the oil level.
6. Add oil as needed so that it fills 1/2 to 3/4 of the sightglass.
7. Torque the sightglass to 9 Nm (6 ft.lbs.).

Changing oil

Perform the following procedure to change the ramming system oil.

Note: *Dispose of used oil in accordance with local environmental regulations.*

1. Remove the drain plug **(b)**. (On BS 50 machines, remove the sightglass **(a)**.)

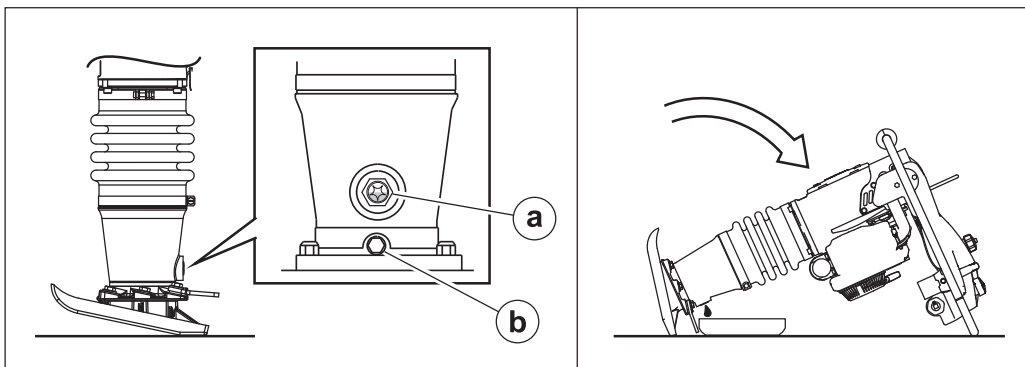

wc_gr007410

2. Tilt the rammer backward until it is resting on the handle and drain the oil into a suitable container.

Note: *It may take up to 10 minutes for the oil to drain.*

3. Re-install the drain plug. Torque it to 54 Nm (40 ft.lbs.).
4. Add oil as stated above.

Result

The ramming system oil has now been changed.

5.5 Checking the Fuel Lines and Fittings

When Daily before starting the machine

Procedure 1. Check the fuel lines **(a)** and fittings **(b)** for cracks and leaks.

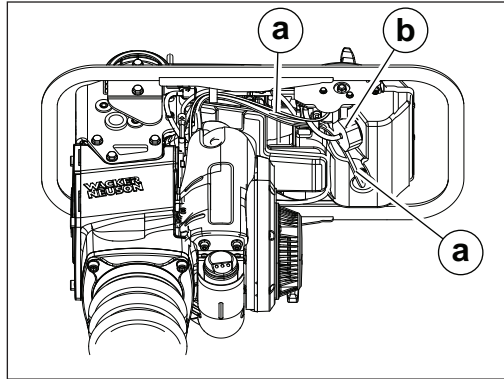

wc_gr010410

2. Repair or replace components as needed.

Result The fuel lines and fittings have now been checked.

5.6 Maintaining the Shoe Hardware

When On new machines, or after replacing shoe, check and tighten shoe hardware after the first five hours of operation. Inspect hardware every week thereafter.

Procedure Torque hardware as specified.

Cast Iron Shoe

Plastic Shoe

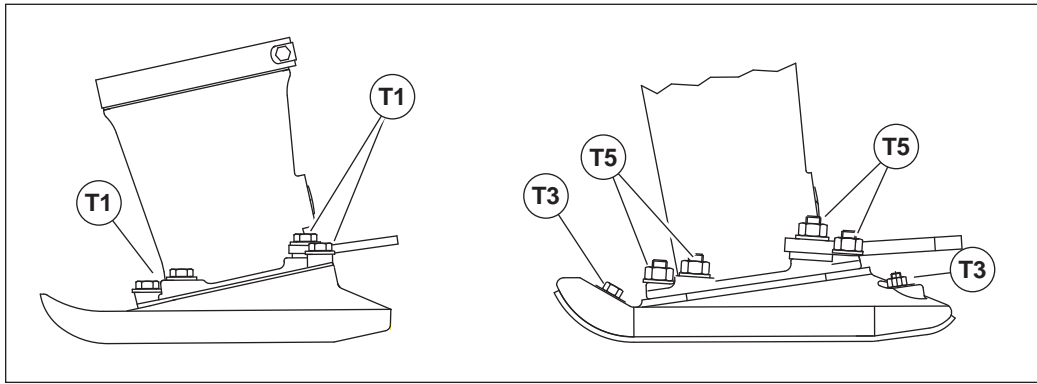

wc_gr005385

Torque	Nm	ft.lbs.
T1	86	63
T3	19	14
T5	79	58

5.7 Inspecting the Machine

When After the first five hours, and every week or every 25 hours thereafter (whichever comes first)

- Requirements**
- Engine stopped
 - Machine cool to the touch
 - Replacement parts as needed (refer to the Parts Book)
-

- Procedure**
1. Perform a walk-around inspection of the machine. Check for:
 - Loose or missing fasteners
 - Cracked, corroded, or missing parts
 - Damaged controls
-



CAUTION

Injury hazard.

- ▶ Do not operate the machine if any safety devices, guards, controls, or fasteners are loose, missing, or inoperative.
-

2. Tighten loose fasteners. Replace missing fasteners as needed.
 3. Replace damaged or missing parts. Use only Wacker Neuson replacement parts or those parts equivalent to the original in all types of specifications, such as physical dimensions, type, strength, and material.
-

Result The machine has now been inspected.

5.8 Cleaning the Engine Cooling Fins

When Every week, or every 25 hours (whichever comes first)

Background Clean engine cooling fins allow fresh air to freely circulate around the combustion chamber. Free air circulation is necessary to prevent the engine from overheating.

Requirements

- Engine stopped and cool to the touch
- Compressed air

Procedure Perform the procedure below to clean the engine cooling fins.

1. Locate the engine cooling fins **(a)**.

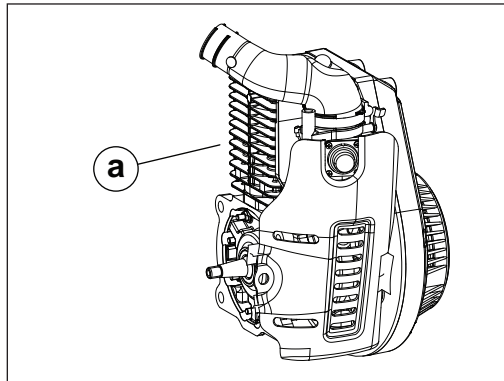

wc_gr011470

2. Use compressed air to blow dirt and debris off the engine cooling fins.

Result The engine cooling fins have been cleaned.

5.9 Cleaning and Checking the Spark Plug

When Every week, or every 25 hours (whichever comes first)

- Requirements**
- Engine stopped and cool to the touch
 - Spark plug wrench
 - Spark plug gap tool
 - Wire brush
 - Replacement spark plug as needed (see *Technical Data*)



WARNING

Burn hazard. The engine and muffler become very hot during operation and require cool-down time after the engine is stopped.

- ▶ Do not touch the engine, muffler, or spark plug until the machine is cool.

Procedure Perform the procedure below to clean and check the spark plug.

1. Disconnect the spark plug wire **(b)** and remove the spark plug **(a)**.

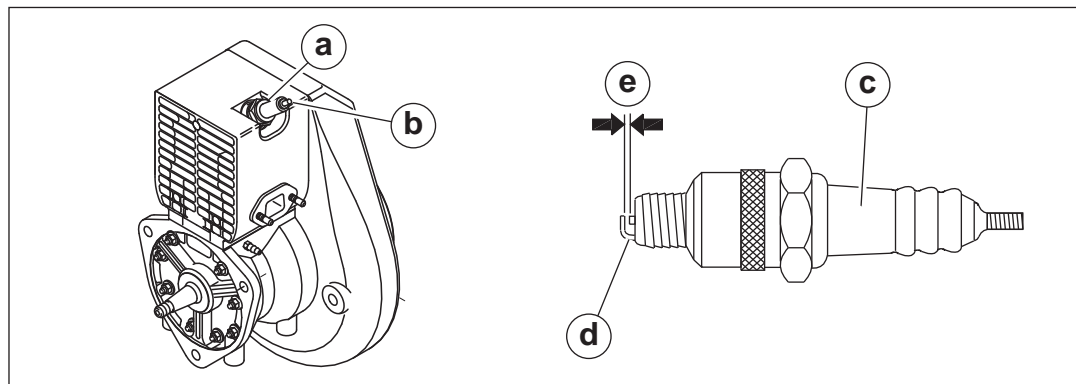

wc_gr011518

2. Inspect the spark plug. Replace the spark plug if the insulator **(c)** is cracked or chipped.
3. Clean spark plug electrodes **(d)** with a wire brush to remove carbon deposits.
4. Check the electrode gap **(e)** and adjust as needed. See *Technical Data* for the recommended gap setting.
5. Reinstall the spark plug and torque it to 35–41 Nm (25.8–30.2 ft.lbs.).

NOTICE: A loose spark plug can become very hot and may cause engine damage.

Result The spark plug has now been cleaned and checked.

5.10 Inspecting and Cleaning the Fuel Filter

When Every year or every 1200 hours (whichever comes first)

- Requirements**
- Engine stopped
 - Fuel tank empty
 - Clean, dry, lint-free cloth
 - Replacement fuel filter (as needed)

Procedure Perform the procedure below to clean the fuel filter.

1. Clamp, then disconnect the fuel hose **(b)** from the fuel filter **(a)**.

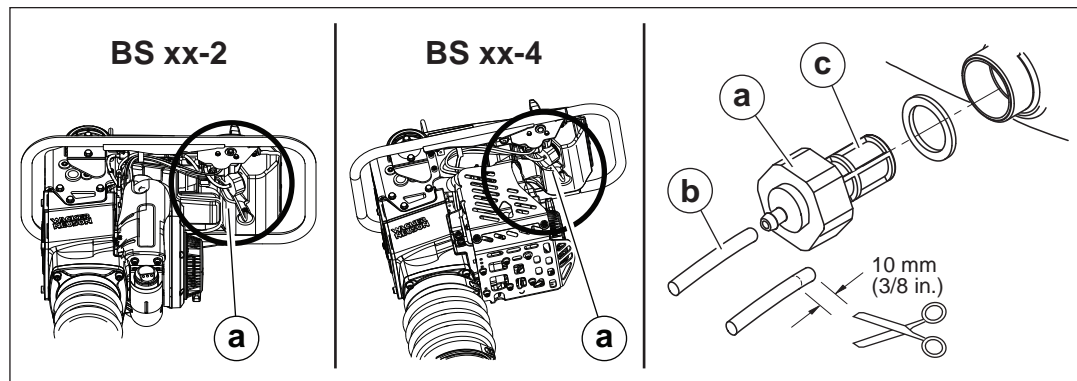

wc_gr010412

2. Unscrew and remove the fuel filter.
3. Wipe visible sediment or debris from the exterior of the fuel filter screen **(c)** using a clean, dry, lint-free cloth.
4. Inspect the fuel filter screen for cracks or damage. Replace the fuel filter if it is damaged.
5. Re-install the fuel filter.
6. To ensure a proper connection, cut approximately 10 mm (3/8 in.) from the end of the fuel hose, then connect it to the fuel filter.
7. Check for fuel leaks before restarting the machine.

Result The fuel filter has now been inspected and cleaned.

5.11 Replacing the In-Line Fuel Filter Assembly

When Every 5 months or every 500 hours (whichever comes first)

- Requirements**
- Engine stopped
 - Replacement in-line fuel filter assembly

Procedure Perform the procedure below to replace the in-line fuel filter assembly. The in-line fuel filter assembly consists of the fuel filter **(a)** and two hoses **(b)**.

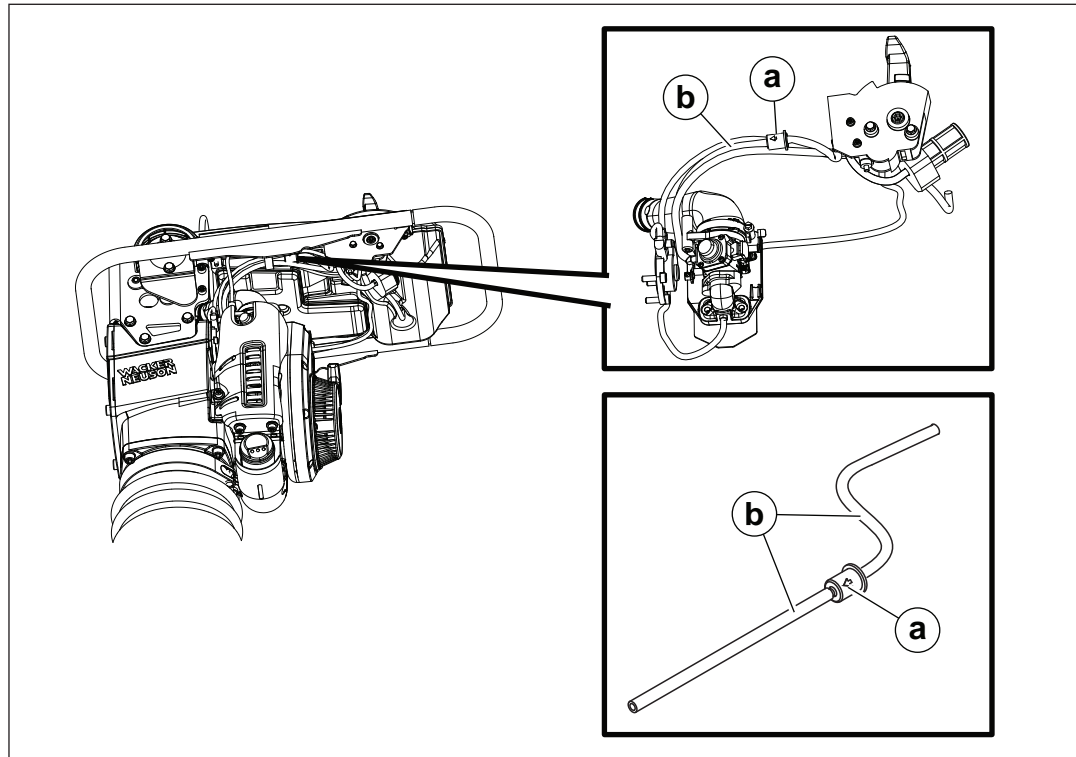

wc_gr012473

1. Set the throttle to the OFF position. This will close the fuel valve.
2. Remove the existing in-line fuel filter assembly and discard it in accordance with local environmental protection regulations.
3. Connect the new in-line fuel filter assembly, making sure to orient the fuel filter as shown in the illustration.
4. Set the throttle to the IDLE position. This will open the fuel valve.
5. Check for fuel leaks before restarting the machine.

Result The in-line fuel filter assembly has now been replaced.

5.12 Adjusting the Idle Speed

- Requirements**
- Tachometer
 - Phillips screwdriver

Procedure Perform the procedure below to adjust the idle speed.

1. Remove the guard **(c)**.

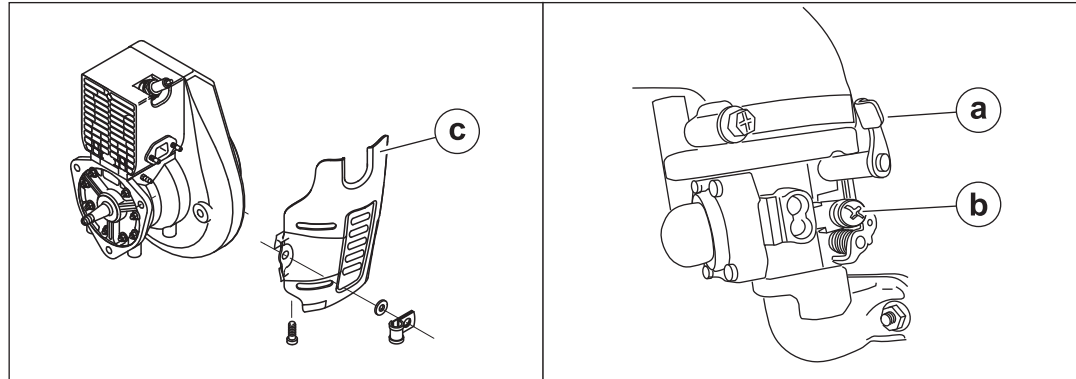

wc_gr007402

2. Start the engine and allow it to warm up to operating temperature.
3. Using the tachometer, set the engine idle speed with engine running at idle and choke **(a)** fully open.
4. Adjust idle speed screw **(b)** in or out to obtain correct idle speed. Refer to *Technical Data* for correct idle and operating rpm.

NOTICE: Do not over-tighten the idle speed screw. Damage to the carburetor may occur.

5. Re-install the guard.

Result The idle speed has now been adjusted.

5.13 Long-Term Storage

Introduction	This machine requires preventive maintenance before long-term storage. Performing preventive maintenance helps to preserve machine components and ensures that the machine will be ready for future use.
When	Prepare your machine for extended storage if it will not be operated for 30 days or more.
Preparing for storage	<p>Follow the procedures below to prepare your machine for storage.</p> <ol style="list-style-type: none"> 1. Complete any needed repairs. 2. Replenish or change oils (engine, ramming system, etc.) per the intervals specified in the Periodic Maintenance table. 3. 4-cycle machines only: Consult the engine owner's manual for instructions on preparing the engine for storage.
Stabilizing the fuel	<p>After completing the procedures listed above, fill the fuel tank completely and add a high-quality stabilizer to the fuel.</p> <ul style="list-style-type: none"> ■ Choose a stabilizer that includes cleaning agents and additives designed to coat/protect the cylinder walls. ■ Make sure the stabilizer you use is compatible with the fuel in your area, fuel type, grade, and temperature range. Do not add extra alcohol to fuels which already contain it (for example, E10). ■ Add the correct amount of stabilizer per the manufacturer's recommendations.
Storing the machine	<p>Perform these remaining steps to store your machine.</p> <ol style="list-style-type: none"> 1. Wash the machine and allow it to dry. 2. Move the machine to a clean, dry, secure storage location. 3. Secure the machine in an upright position. 4. Cover the machine.

5.14 Machine Disposal / Decommissioning

Introduction This machine must be properly decommissioned at the end of its service life. Responsible disposal of recyclable components, such as plastic and metal, ensures that these materials can be reused—conserving landfill space and valuable natural resources.

Responsible disposal also prevents toxic chemicals and materials from harming the environment. The operating fluids in this machine, including fuel, engine oil, ramming system oil, and grease, may be considered hazardous waste in many areas. Before decommissioning this machine, read and follow local safety and environmental regulations pertaining to the disposal of construction equipment.

Preparation Perform the following tasks to prepare the machine for disposal.

- Move the machine to a protected location where it will not pose any safety hazards and cannot be accessed by unauthorized individuals.
- Ensure that the machine cannot be operated from the time of final shutdown to disposal.
- Drain all fluids, including fuel, engine oil, and ramming system oil.
- Seal any fluid leaks.

Disposal Perform the following tasks to dispose of the machine.

- Disassemble the machine and separate all parts by material type.
- Dispose of recyclable parts as specified by local regulations.
- Dispose of all non-hazardous components that cannot be recycled.
- Dispose of waste fuel, oil, and grease in accordance with local environmental protection regulations.

6 Troubleshooting

Problem	Cause	Remedy
Engine does not start, or stalls.	No fuel in tank	Add fuel.
	Spark plug fouled	Clean or replace spark plug.
Engine does not accelerate, is hard to start, or runs erratically.	Spark plug fouled	Clean or replace spark plug.
	Obstructed muffler and/or exhaust port	Clear obstructions.
	Dirty or clogged air cleaner	Service air cleaner.
Engine overheats.	Dirty cooling fins	Clean the cooling fins.
Engine runs, but rammer does not tamp.	Obstructed exhaust port	Clear obstructions.
Engine runs, but rammer operation is erratic.	Oil or grease on clutch	Remove oil/grease from clutch.
	Soil buildup on ramming shoe	Clean soil from ramming shoe.
	Engine operating speed too high	Adjust engine operating speed.
Oil injection models only: Engine starts and runs for a short time—approximately 30 seconds—then stops.	Low oil level	Add oil to oil tank.

7 Technical Data

7.1 BS 50-2i

Machine		BS 50-2i
Engine model	—	WM80
Engine speed - operating	rpm	4400 ± 100
Engine speed - idle	rpm	2000 ± 100
Maximum rated power @ rated speed ¹	kW (hp)	1.7 (2.2) @ 4400 rpm
Clutch engagement	rpm	2500 ± 100
Spark plug	type	Champion QL87YC
Electrode gap	mm (in.)	0.76 (0.030)
Cylinder head compression (cold)	bar/cm ² (psi)	8.0–9.7 (120–140)
Air cleaner	type	Four-stage with cyclonic precleaner
Fuel specification	type	Regular unleaded gasoline (minimum 85 octane)
Oil specification, 2-cycle	type	Wacker Neuson 2-cycle or other fully synthetic oil meeting the NMMA TC-W3, JASO FD, or ISO-L-EGD specification.
Oil tank capacity	L (qt)	1.3 (1.4)
Fuel tank capacity	L (qt)	3.0 (3.2)
Fuel consumption	L (qt)/hr	1.0 (1.1)
Running time	hr	2.9
Ramming system lubrication	type	SAE 10W30
Ramming system oil capacity	ml (oz.)	710 (24)

¹ Net engine power rating per 80/1269/EEC and ISO 3046-1. Actual power output may vary due to conditions of specific use.

7.2 BS 50-2i Operating Weight

Machine Item Number		BS 50-2i 5200000642 5200000660 5200000687 5200000678 5200025428	BS 50-2i 5200000643 5200000658 5200000659 5200000687 5200025429	BS 50-2i 5200000661	BS 50-2i 5200000657 5200011099
Operating weight	kg (lb)	59 (131)	58 (129)	57 (126)	56 (124)

7.3 BS 60-2i

Machine		BS 60-2i
Engine model	—	WM80
Engine speed - operating	rpm	4400 ± 100
Engine speed - idle	rpm	2000 ± 100
Max. rated power @ rated speed ¹	kW (hp)	1.8 (2.4) @ 4400 rpm
Clutch engagement	rpm	2500 ± 100
Spark plug	type	Champion QL87YC
Electrode gap	mm (in.)	0.76 (0.030)
Cylinder head compression (cold)	bar/cm ² (psi)	8.0–9.7 (120–140)
Air cleaner	type	Four stage with cyclonic precleaner
Fuel specification	type	Regular unleaded gasoline
Oil specification, 2-cycle	type	Wacker Neuson two-cycle or other fully synthetic oil meeting the NMMA TC-W3, JASO FD, or ISO-L-EGD specification
Oil tank capacity	L (qt)	1.3 (1.4)
Fuel tank capacity	L (qt)	3.0 (3.2)
Fuel consumption	L (qt)/hr	1.2 (1.3)
Running time	hr	2.5
Ramming system lubrication	type	SAE 10W/30
Ramming system capacity	ml (oz.)	890 (30)

¹ Net engine power rating per 80/1269/EEC and ISO 3046-1. Actual power output may vary due to conditions of specific use.

7.4 BS 60-2i Operating Weight

Machine Item Number		BS 60-2i	BS 60-2i
		5200000645 5200000664 5200000682 5200000689 5200000690	5200000646 5200000665
Operating weight	kg (lb)	66 (145)	64 (141)

7.5 BS 70-2i

Machine		BS 70-2i
Engine model	—	WM80
Engine speed - operating	rpm	4400 ± 100
Engine speed - idle	rpm	2000 ± 100
Max. rated power @ rated speed ¹	kW (hp)	2.0 (2.7) @ 4400 rpm
Clutch engagement	rpm	2500 ± 100
Spark plug	type	Champion QL87YC
Electrode gap	mm (in.)	0.76 (0.030)
Cylinder head compression (cold)	bar/cm ² (psi)	8.0–9.7 (120–140)
Air cleaner	type	Four stage with cyclonic precleaner
Fuel specification	type	Regular unleaded gasoline
Oil specification, 2-cycle	type	Wacker Neuson two-cycle or other fully synthetic oil meeting the NMMA TC-W3, JASO FD, or ISO-L-EGD specification
Oil tank capacity	L (qt)	1.3 (1.4)
Fuel tank capacity	L (qt)	3.0 (3.2)
Fuel consumption	L (qt)/hr	1.3 (1.4)
Running time	hr	2.3
Ramming system lubrication	type	SAE 10W30
Ramming system capacity	ml (oz.)	890 (30)

¹ Net engine power rating per 80/1269/EEC and ISO 3046-1. Actual power output may vary due to conditions of specific use.

7.6 BS 70-2i Operating Weight

Machine Item Number		BS 70-2i 5200000649, 5200000650, 5200000672, 5200000673
Operating weight	kg (lb)	74 (164)

7.7 BS 50-2

Machine		BS 50-2
Engine model	—	WM80
Engine speed - operating	rpm	4400
Engine speed - idle	rpm	2000 ± 100
Max. rated power @ rated speed ¹	kW (hp)	1.7 (2.2) @ 4400 rpm
Clutch engagement	rpm	2500 ± 100
Spark plug	type	Champion QL87YC
Electrode gap	mm (in.)	0.76 (0.030)
Cylinder head compression (cold)	bar/cm ² (psi)	8.0–9.7 (120–140)
Air cleaner	type	Four-stage with cyclonic precleaner
Fuel specification	—	Gasoline-oil mixture
Gasoline/2-cycle oil mixing ratio	—	50:1 – 100:1
Oil specification, 2-cycle	—	Use only Wacker Neuson two-cycle or other fully synthetic oil meeting the NMMA TC-W3, JASO FD, or ISO-L-EGD specification. A gasoline/oil ratio in a range from 50:1 to 100:1 can be used. For optimum engine performance and durability, a 100:1 ratio with a fully synthetic oil meeting the specification described above is preferred.
Fuel tank capacity	L (qt)	3.0 (3.2)
Fuel consumption	L (qt)/hr	1.2 (1.3)
Running time	hr	2.9
Ramming system lubrication	type	SAE 10W30
Ramming system oil capacity	ml (oz.)	710 (24)

¹ Net engine power rating per 80/1269/EEC and ISO 3046-1. Actual power output may vary due to conditions of specific use.

7.8 BS 50-2 Operating Weight

Machine Item Number		BS 50-2 5200000641	BS 50-2 5200000655	BS 50-2 5200000653 5200000652	BS 50-2 5200000654 5200000685 5200000686	BS 50-2 5200000656
Operating weight	kg (lb)	59 (129)	59 (131)	56 (124)	58 (129)	57 (126)

7.9 BS 60-2

Machine		BS 60-2
Engine model	—	WM80
Engine speed - operating	rpm	4400
Engine speed - idle	rpm	2000 ± 100
Max. rated power @ rated speed ¹	kW (hp)	1.8 (2.4) @ 4400 rpm
Clutch engagement	rpm	2500 ± 100
Spark plug	type	Champion QL95YC
Electrode gap	mm (in.)	0.76 (0.030)
Cylinder head compression (cold)	bar/cm ² (psi)	8.0–9.7 (120–140)
Air cleaner	type	Four-stage with cyclonic precleaner
Fuel specification	—	Gasoline-oil mixture
Gasoline/2-cycle oil mixing ratio	—	50:1 – 100:1
Gasoline specification	—	Regular unleaded gasoline (minimum 85 octane)
Oil specification, 2-cycle	—	Use only Wacker Neuson two-cycle or other fully synthetic oil meeting the NMMA TC-W3, JASO FD, or ISO-L-EGD specification. A gasoline/oil ratio in a range from 50:1 to 100:1 can be used. For optimum engine performance and durability, a 100:1 ratio with a fully synthetic oil meeting the specification described above is preferred.
Fuel tank capacity	L (qt)	3.0 (3.2)
Fuel consumption	L (qt)/hr	1.2 (1.3)
Running time	hr	2.5
Ramming system lubrication	type	SAE 10W30
Ramming system oil capacity	ml (oz.)	890 (30)

¹ Net engine power rating per 80/1269/EEC and ISO 3046-1. Actual power output may vary due to conditions of specific use.

7.10 BS 60-2 Operating Weight

Machine Item Number		BS 60-2 5200000663, 5200000688, 5200019205
Operating weight	kg (lb)	66 (143)

7.11 BS 70-2

Machine		BS 70-2
Engine model	—	WM80
Engine speed - operating	rpm	4400
Engine speed - idle	rpm	2000 ± 100
Max. rated power @ rated speed ¹	kW (hp)	2.0 (2.7) @ 4400 rpm
Clutch engagement	rpm	2500 ± 100
Spark plug	type	Champion QL87YC
Electrode gap	mm (in.)	0,76
Cylinder head compression (cold)	bar/cm ² (psi)	8.0–9.7 (120–140)
Air cleaner	type	Four-stage with cyclonic precleaner
Fuel specification	—	Gasoline-oil mixture
Gasoline/2-cycle oil mixing ratio	—	50:1 – 100:1
Oil specification, 2-cycle	—	Use only Wacker Neuson two-cycle or other fully synthetic oil meeting the NMMA TC-W3, JASO FD, or ISO-L-EGD specification. A gasoline/oil ratio in a range from 50:1 to 100:1 can be used. For optimum engine performance and durability, a 100:1 ratio with a fully synthetic oil meeting the specification described above is preferred.
Fuel tank capacity	L (qt)	3.0 (3.2)
Fuel consumption	L (qt)/hr	1.3 (1.4)
Running time	hr	2.3
Ramming system lubrication	type	SAE 10W30
Ramming system oil capacity	ml (oz.)	890 (30)

¹Net engine power rating per 80/1269/EEC and ISO 3046-1. Actual power output may vary due to conditions of specific use.

7.12 BS 70-2 Operating Weight

Machine Item Number		BS 70-2 5200000670, 5200000671
Operating weight	kg (lb)	74 (164)

7.13 BS 65-V

Machine		BS 65-V
Engine model	—	WM80
Engine speed - operating	rpm	4400 ± 100
Engine speed - idle	rpm	1800 ± 100
Max. rated power @ rated speed ¹	kW/hp	2.0 (2.7) @ 4400 rpm
Clutch engagement	rpm	2500 ± 100
Spark plug	type	Champion QL87YC
Electrode gap	mm (in.)	0.76 (0.030)
Cylinder head compression (cold)	bar/cm ³ (psi)	8.0–9.7 (120–140)
Air cleaner	type	Four-stage with cyclonic precleaner
Fuel specification	—	Gasoline-oil mixture
Gasoline/2-cycle oil mixing ratio	—	50:1 – 100:1
Oil specification, 2-cycle	—	Use only Wacker Neuson two-cycle or other fully synthetic oil meeting the NMMA TC-W3, JASO FD, or ISO-L-EGD specification. A gasoline/oil ratio in a range from 50:1 to 100:1 can be used. For optimum engine performance and durability, a 100:1 ratio with a fully synthetic oil meeting the specification described above is preferred.
Fuel tank capacity	L (qt)	3.0 (3.2)
Fuel consumption	L (qt)/hr	1.2 (1.3)
Running time	hr	2.5
Ramming system lubrication	oil grade	SAE 10W30, service class SJ or higher
Ramming system oil capacity	ml (oz.)	890 (30)

¹ Net engine power rating per 80/1269/EEC and ISO 3046-1. Actual power output may vary due to conditions of specific use.

7.14 BS 65-V Operating Weight

Machine Item Number		BS 65-V 5200000669
Operating weight	kg (lb)	68 (150)

7.15 Sound Measurements

Products are tested for sound pressure level in accordance with EN 500-4:2011.
 Sound power level is tested in accordance with European Directive 2000/14/EC -
 Noise Emission in the Environment by Equipment for use outdoors.

Machine	Sound Pressure at Operator's Location dB(A)	Guaranteed Sound Power dB(A)
BS 50-2i	92	108
BS 60-2i	92	
BS 70-2i	93	
BS 50-2	92	108
BS 60-2	92	
BS 70-2	93	
BS 65-V	92	108

7.16 Vibration Measurements

Products are tested for hand/arm vibration (HAV) level in accordance with ISO 5349, EN1033, and EN500-4 where applicable.

Machine	Item number	HAV m/sec ²	HAV ft/sec ²
BS 50-2i	5200000642, 5200000643, 5200000659, 5200000660, 5200000658, 5200000678, 5200025428, 5200025429	9.8	32.1
	5200000661, 5200000657, 5200011099, 5200000687	5.4	17.7
BS 60-2i	5200000645, 5200000646, 5200000664, 5200000665, 5200000689, 5200000690, 5200000682	7.6	24.9
BS 70-2i	5200000649, 5200000650, 5200000673, 5200000672	6.8	22.3
BS 50-2	5200000655, 5200000654, 5200000685	9.8	32.1
	5200000641, 5200000652, 5200000656, 5200000653, 5200000686	5.4	17.7
BS 60-2	5200000663, 5200000688, 5200019205	7.6	24.9
BS 70-2	5200000670, 5200000671	6.8	22.3
BS 65-V	5200000663	8.6	28.2

HAV Hand-transmitted vibration was measured per ISO 5349-1. This measurement
Uncertainties includes an uncertainty of 1.5 m/s².

7.17 Dimensions—BS 50-2i, BS 50-2

mm (in.)

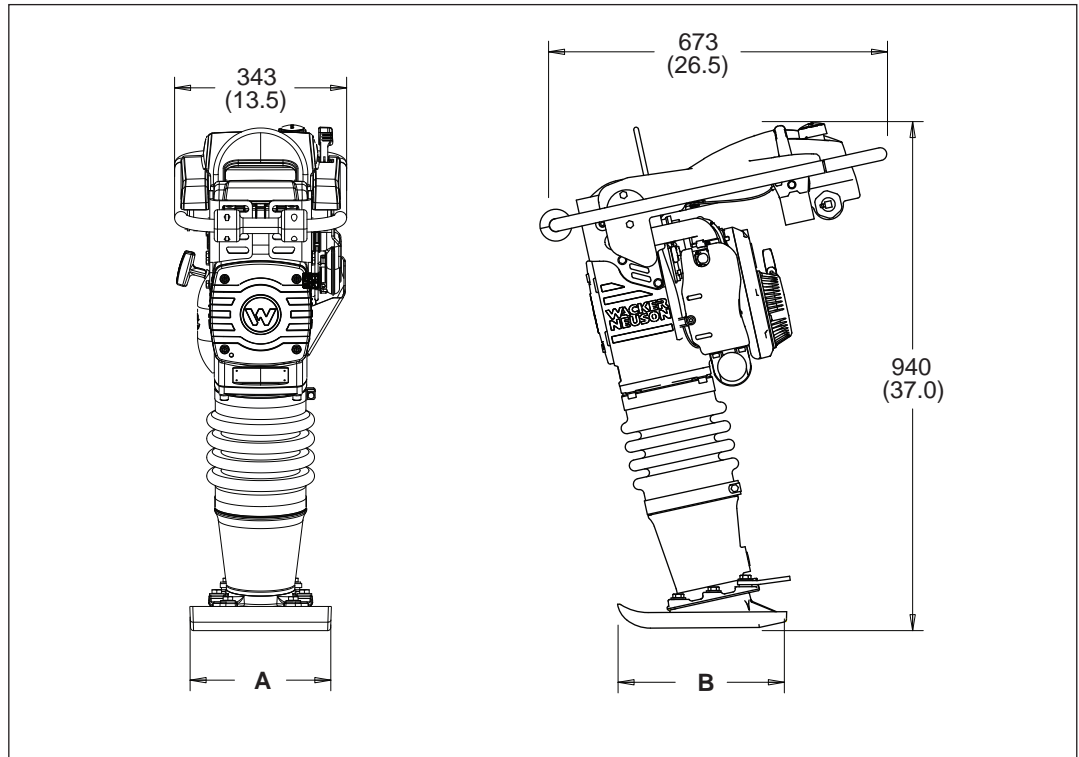

wc_gr011405

BS 50-2i	BS 50-2	A mm (in.)	B mm (in.)
5200000642 5200000660 5200000687 5200000678 5200025428	5200000656 5200000686	280 (11.03)	337 (13.27)
5200000643 5200000658 5200000659 5200025429	5200000641 5200000654 5200000685	250 (9.84)	337 (13.25)
5200000661 5200000687	5200000655	280 (11.03)	344 (13.55)
5200000657	5200000652	165 (6.50)	337 (13.25)
5200011099	5200000653	190 (7.50)	344 (13.55)

7.18 Dimensions—BS 60-2i, BS 60-2, BS 70-2i, BS 70-2, BS 65-V

mm (in.)

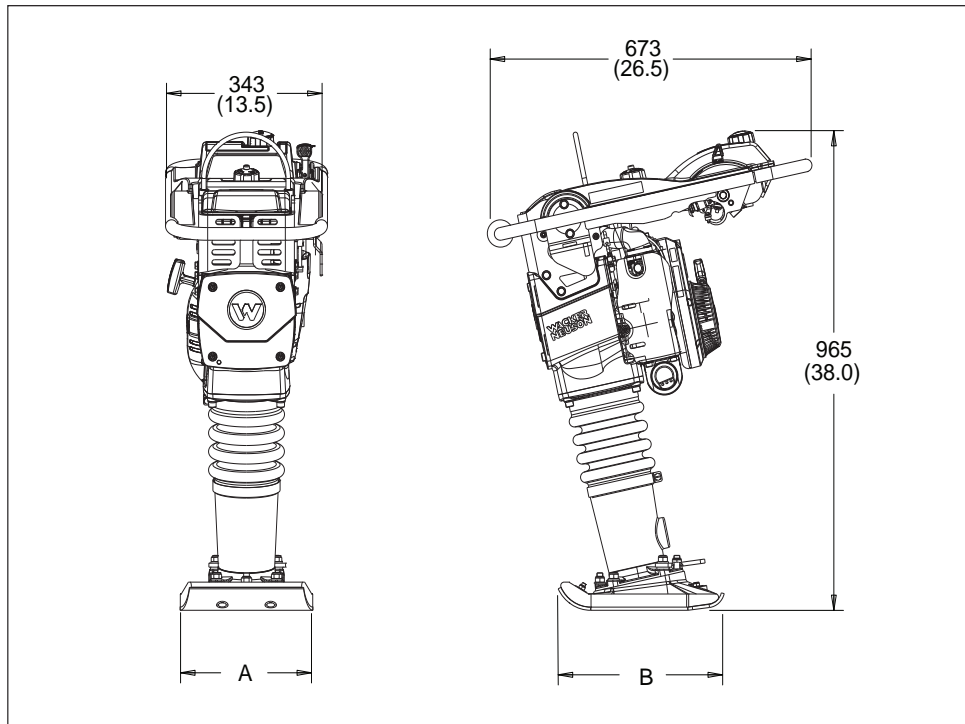

wc_gr011411

BS 60-2i	BS 60-2	A mm (in.)	B mm (in.)
5200000645 5200000664 5200000689 5200000682	5200000663 5200000688 5200019205	280 (11.02)	336 (13.25)
5200000646 5200000665 5200000690	—	280 (11.02)	342 (13.45)

BS 70-2i	BS 70-2	A mm (in.)	B mm (in.)
5200000649 5200000673	5200000671	330 (12.99)	342 (13.45)
5200000650 5200000672	5200000670	280 (11.02)	336 (13.25)

BS 65-V	A mm (in.)	B mm (in.)
5200000669	280 (11.02)	336 (13.25)

8 Emission Control Systems Information and Warranty—Gasoline

The Emission Control Warranty and associated information is valid only for the U.S.A., its territories, and Canada.

8.1 Emission Control System Background Information

Introduction

Wacker Neuson spark-ignited engines/equipment must conform with applicable Environmental Protection Agency (EPA) emissions regulations. There are two types of emissions that fall under these regulations: 1) exhaust, and 2) evaporative. These regulations require that manufacturers warrant the emission control systems for defects in materials and workmanship.

Furthermore, EPA regulations require all manufacturers to furnish written instructions describing how to operate and maintain the engines/equipment including the emission control systems. This information is provided with all Wacker Neuson engines/equipment at the time of purchase.

Exhaust Emissions

The combustion process produces carbon monoxide, oxides of nitrogen, and hydrocarbons. Control of hydrocarbons and oxides of nitrogen is very important because, under certain conditions, they react to form photochemical smog when subjected to sunlight. Carbon monoxide does not react in the same way, but it is toxic.

Wacker Neuson utilizes lean carburetor settings and other systems to reduce the emissions of carbon monoxide, oxides of nitrogen, and hydrocarbons.

Evaporative Emissions

Evaporative emissions are fuel emissions and generally include emissions that result from permeation of fuel through the fuel-system materials or from ventilation of the fuel system.

Wacker Neuson utilizes low-permeation fuel lines and fuel tanks where applicable to reduce evaporative emissions.

Problems that may affect Emissions

If any of the following symptoms arise, have the engine/equipment inspected and repaired by a Wacker Neuson dealer/service center.

- Hard starting or stalling after starting
- Rough idling
- Misfiring or backfiring under load
- Afterburning (backfiring)
- Presence of black exhaust smoke during operation
- High fuel consumption

Tampering and Altering

Tampering with or altering the emission control system may increase emissions beyond the legal limit. If evidence of tampering is found, Wacker Neuson may deny a warranty claim. Among those acts that constitute tampering are:

- Removing or altering of any part of the air intake, fuel, or exhaust systems.
- Altering or defeating the speed-adjusting mechanism causing the engine to operate outside its design parameters.

8.2 Limited Defect Warranty for Wacker Neuson Emission Control Systems

The Emission Control Warranty is valid only for the U.S.A., its territories, and Canada.

Wacker Neuson Sales Americas, LLC, N92 W15000 Anthony Avenue, Menomonee Falls, WI 53051, (hereinafter “Wacker Neuson”) warrants to the initial retail purchaser, and each subsequent owner, that this engine/equipment, including all parts of its emission control systems, have been designed, built, and equipped to conform at the time of initial sale to all applicable emission regulations of the U.S. Environmental Protection Agency (EPA), and that the engine/equipment is free of defects in materials and workmanship which would cause this engine/equipment to fail to conform to EPA regulations during its warranty period.

Wacker Neuson is also liable for damages to other engine/equipment components caused by a failure of any warranted parts during the warranty period.

Limited Defect Warranty Period for Wacker Neuson Emission Control Systems

The warranty period for this engine/equipment begins on the date of sale to the initial purchaser and continues for a minimum of two (2) years. For the warranty terms for your specific engine/equipment, visit wackerneuson.com.

Any implied warranties are limited to the duration of this written warranty.

What is covered

Wacker Neuson recommends the use of genuine Wacker Neuson parts, or the equivalent, whenever maintenance is performed. The use of replacement parts not equivalent to the original parts may impair the effectiveness of the engine/equipment emission controls systems. If such a replacement part is used in the repair or maintenance of the engine/equipment, assure yourself that such part is warranted by its manufacturer to be equivalent to the parts offered by Wacker Neuson in performance and durability. Furthermore, if such a replacement part is used in the repair or maintenance of the engine/equipment, and an authorized Wacker Neuson dealer/service center determines it is defective or causes a failure of a warranted part, the claim for repair of the engine/equipment may be denied. If the part in question is not related to the reason the engine/equipment requires repair, the claim will not be denied.

Emission Control Systems Information and Warranty—Gasoline

For the components listed in the following table, an authorized Wacker Neuson dealer/service center will, at no cost to you, make the necessary diagnosis, repair, or replacement necessary to ensure that the engine/equipment complies with the applicable EPA regulations. All defective parts replaced under this warranty become property of Wacker Neuson.

Exhaust Emissions

Systems Covered	Components
Fuel metering system	Carburetor and internal parts
	Air/fuel ratio feedback system (if applicable)
	Cold start enrichment system (if applicable)
	Regulator assembly (if applicable)
Exhaust system	Catalytic muffler (if applicable)
	Exhaust manifold (if applicable)
Air induction system	Air filter housing
	Air filter element*
	Intake manifold (if applicable)
Ignition system	Flywheel magneto
	Ignition module
	Electronic controls (if applicable)
	Spark advance/retard system (if applicable)
	Spark plug cap
	Spark plug*
Miscellaneous parts associated with the exhaust emission control system	Tubing
	Fittings
	Seals
	Gaskets
	Clamps

* Indicates expendable maintenance items. Warranted only to first scheduled replacement point.

Emission Control Systems Information and Warranty—Gasoline

Evaporative Emissions

Systems Covered	Components
Evaporative control system	Fuel tank (if applicable)
	Fuel tank cap (if applicable)
	Fuel line (if applicable)
	Fuel line fittings (if applicable)
	Clamps (if applicable)
	Carbon canister (if applicable)
	Purge port connector (if applicable)
Miscellaneous parts associated with the evaporative emission control system	Clamps
	Gaskets
	Mounting brackets

What is not covered

- Failures other than those resulting from defects in material or workmanship.
- Any systems or parts which are affected or damaged by owner abuse, tampering, neglect, improper maintenance, misuse, improper fueling, improper storage, accident and/or collision; the incorporation of, or any use of, add-on or modified parts, or unsuitable attachments, or the alteration of any part.
- Replacement of expendable maintenance items made in connection with required maintenance services after the item's first scheduled replacement as listed in the maintenance section of the engine/equipment operator's manual, such as spark plugs and filters.
- Incidental or consequential damages such as loss of time or the use of the engine/equipment, or any commercial loss due to the failure of the engine/equipment.
- Diagnosis and inspection charges that do not result in warranty-eligible service being performed.
- Any non-authorized replacement part, or malfunction of authorized parts due to use of non-authorized parts.

Emission Control Systems Information and Warranty—Gasoline

Owner's Warranty Responsibility

The engine/equipment owner is responsible for the performance of the required maintenance listed in the Wacker Neuson engine/equipment operator's manual. Wacker Neuson recommends that all receipts covering maintenance on the engine/equipment be retained, but Wacker Neuson cannot deny warranty coverage solely for the lack of receipts or for the failure to ensure the performance of all scheduled maintenance.

Normal maintenance, replacement, or repair of emission control devices and systems may be performed by any repair establishment or individual; however, warranty repairs must be performed by an authorized Wacker Neuson dealer/service center.

The engine/equipment must be presented to an authorized Wacker Neuson dealer/service center as soon as a problem exists. Contact Wacker Neuson Product Support Department (1-800-770-0957) or visit wackerneuson.com to find a dealer/service center in your area, or to answer questions regarding warranty rights and responsibilities.

How to Make a Claim

In the event that any emission-related part is found to be defective during the warranty period, you shall notify Wacker Neuson Product Support Department (1-800-770-0957, or technical.support@wackerneuson.com, or wackerneuson.com), and you will be advised of the appropriate dealer/service center where warranty repair can be performed. All repairs qualifying under this limited warranty must be performed by an authorized Wacker Neuson dealer/service center.

You must take your Wacker Neuson engine/equipment along with proof of original purchase date, at your expense, to the authorized Wacker Neuson dealer/service center during their normal business hours.

For owners located more than 100 miles from an authorized dealer/service center (excluding the states with high-altitude areas as identified in 40 CFR Part 1068, Appendix III), Wacker Neuson will pay for pre-approved shipping costs to and from an authorized Wacker Neuson dealer/service center.

Claims for repair or adjustment found to be caused solely by defects in material or workmanship will not be denied because the engine/equipment was not properly maintained and used.

The warranty repairs should be completed in a reasonable amount of time, not to exceed 30 days.

Emission Control Systems Information and Warranty—Gasoline

Notes



Important: For spare parts information, please see your Wacker Neuson Dealer, or visit the Wacker Neuson website at <http://www.wackerneuson.com/>.

Wichtig! Informationen über Ersatzteile erhalten Sie von Ihrem Wacker Neuson Händler oder besuchen Sie die Wacker Neuson Website unter <http://www.wackerneuson.com/>.

Important : Pour des informations sur les pièces détachées, merci de consulter votre distributeur Wacker Neuson, ou de visiter le site Internet de Wacker Neuson sur <http://www.wackerneuson.com/>.

Importante : Para saber más sobre las piezas de repuesto, póngase en contacto con su distribuidor de Wacker Neuson o acceda al sitio web de Wacker Neuson en <http://www.wackerneuson.com/>.

Importante : Per informazioni sui pezzi di ricambio, contattare il rivenditore Wacker Neuson o visitare il sito di Wacker Neuson all'indirizzo www.wackerneuson.com.

Viktigt : För information om reservdelar, kontakta din Wacker Neuson-leverantör eller besök Wacker Neusons webbplats på <http://www.wackerneuson.com/>.

Tärkeää : Pyydä varaosatietoja Wacker Neusonin jälleenmyyjältä tai vieraile Wacker Neusonin web-sivustolla osoitteessa <http://www.wackerneuson.com/>

Viktig : For informasjon om reservedeler, vennligst kontakt din Wacker Neuson-forhandler, eller besøk Wacker Neusons nettside på <http://www.wackerneuson.com/>.

Viktigt : Hvis du ønsker opplysninger om reservedele, bedes du kontakte din Wacker Neuson forhandler eller besøk Wacker Neuson websiden på <http://www.wackerneuson.com/>.

Belangrijk! Neem contact op met uw Wacker Neuson dealer of bezoek de website van Wacker Neuson op <http://www.wackerneuson.com/> voor meer informatie over reserveonderdelen.

Importante : Para obter informações sobre as peças sobresselentes, consulte o seu fornecedor da Wacker Neuson ou acesse ao site Web da Wacker Neuson em http://www.wackerneuson.com

Ważne : W celu uzyskania informacji na temat części zamiennych skontaktuj się z przedstawicielem firmy Wacker Neuson lub skorzystaj z witryny internetowej <http://www.wackerneuson.com/>.

Důležitě upozornění! Pro informace o náhradních dílech, prosím, kontaktujte svého Wacker Neuson dealera, nebo navštivte webové stránky <http://www.wackerneuson.com/>.

FONTOS: A pótalkatrészekre vonatkozó információkért kérjük, forduljon Wacker Neuson kereskedőjéhez vagy látogasson el a Wacker Neuson weboldalára a következő címen: <http://www.wackerneuson.com/>.

Важно! Для ознакомления с информацией о запасных частях, пожалуйста, обратитесь к местному торговому представителю компании Wacker Neuson или посетите веб-сайт <http://www.wackerneuson.com/>.

Σημαντικό : Για πληροφορίες σχετικά με τα ανταλλακτικά, μιλήστε με τον αντιπρόσωπό σας της Wacker Neuson, ή επισκεφθείτε τον ιστότοπο <http://www.wackerneuson.com/>.

Važno : Za rezervne dijelove obratite se svom Wacker Neuson prodavaču ili posjetite mrežne stranice tvrtke Wacker Neuson: <http://www.wackerneuson.com/>.

Önemli : Yedek parça bilgileri için Wacker Neuson Bayinize bakın veya Wacker Neuson web sitesini ziyaret edin. <http://www.wackerneuson.com/>

重要 交換部品の情報については、ワッカーノイゾンディーラーにお問い合わせ頂くか、ワッカーノイゾンウェブサイト <http://www.wackerneuson.com/> をご覧ください。

重要 有关备件信息，请咨询您的威克诺森经销商或访问威克诺森网站：
<http://www.wackerneuson.com/>。

Important : Pentru informații referitoare la piesele de schimb, vă rugăm să vă adresați distribuitorului Wacker Neuson sau să vizitați site-ul web Wacker Neuson la adresa <http://www.wackerneuson.com/>.

Важно : За информация относно резервни части, моля, обърнете се към местния дилър на Wacker Neuson или посетете уебсайта на Wacker Neuson на адрес <http://www.wackerneuson.com/>.

Wacker Neuson Produktion GmbH & Co. KG, Preußenstraße 41, D-80809 München,
Tel.: +49-(0)89-3 54 02-0 Fax: +49 - (0)89-3 54 02-390

Wacker Neuson Production Americas LLC, N92W15000 Anthony Ave., Menomonee Falls, WI. 53051
Tel.: (262) 255-0500 Fax: (262) 255-0550 Tel.: (800) 770-0957

Wacker Neuson Limited - Room 1701-03 & 1717-20, 17/F. Tower 1, Grand Century Place, 193 Prince Edward Road West, Mongkok, Kowloon, Hongkong. Tel: (852) 3605 5360, Fax: (852) 2758 0032