

GB

30  
YEARS  
1974 - 2004

# BIBULLDOG ADV

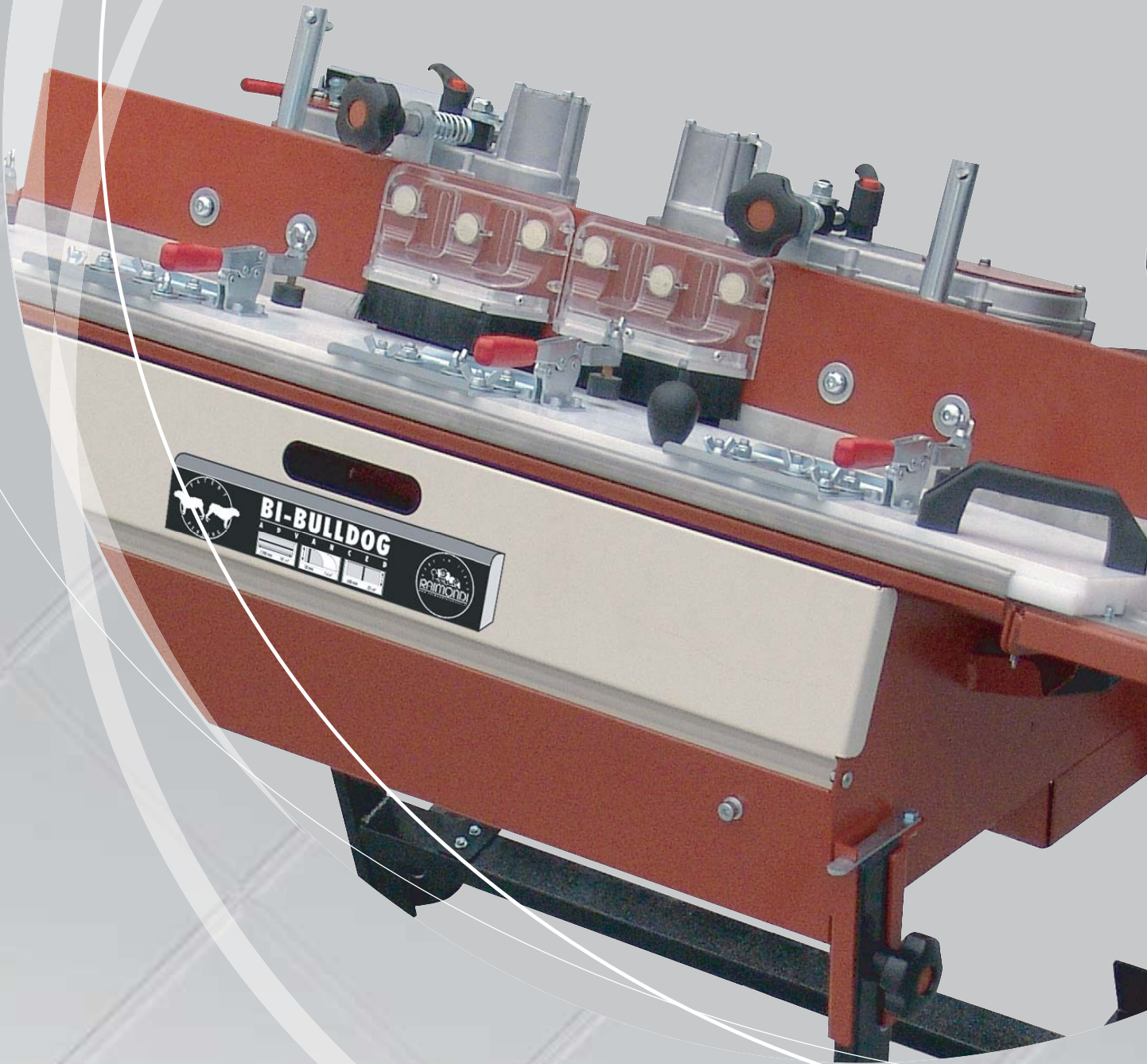

Use and maintenance manual



**RAIMONDI** S.p.A.

[www.raidiondiutensili.it](http://www.raidiondiutensili.it)

## TABLE OF CONTENTS

### CHAPTER 1 INTRODUCTION

1.1	DECLARATION OF CONFORMITY	3/44-1
1.2	TESTING, WARRANTY AND RESPONSIBILITY	4/44-1
1.3	ENVIRONMENTAL CONDITIONS	4/44-1
1.4	INTERVENTION REQUEST AND TECHNICAL SERVICE	5/44-1
1.5	SPARE PARTS ORDERS	5/44-1
1.6	MARKING	5/44-1

### CHAPTER 2 SAFETY RULES

2.1	SAFETY GENERAL RULES	6/44-2
2.2	DEFINITION OF SAFETY-RELATED TERMS	7/44-2
2.3	CORRECT USE OF THE MACHINE	7/44-2
2.4	CHARACTERISTICS OF THE MACHINE	7/44-2
2.5	DESCRIPTION OF MACHINE GROUPS	9/44-2
2.6	POSITION OF THE OPERATOR	10/44-2
2.7	SAFETY DEVICES	10/44-2
2.8	ACCESSORIES OF THE MACHINE	11/44-2
2.9	NOISE	11/44-2
2.10	VIBRATIONS	12/44-2
2.11	DEMOLITION AND DISPOSAL	14/44-2
2.12	CE MANUFACTURER'S DECLARATION	14/44-2

### CHAPTER 3 HANDLING, INSTALLATION, ADJUSTMENTS

3.1	PACKING TRANSPORT	15/44-3
3.2	MANUAL HANDLING	15/44-3
3.3	POWER SUPPLY	16/44-3
3.4	ASSEMBLY OF THE MACHINE	17/44-3
3.4.1	TANK FILLING	18/44-3

### CHAPTER 4 USE OF THE COMMANDS

4.1	ADJUSTING THE GRINDING WHEEL FOR HALF-ROUND SHAPING	19/44-4
4.2	ADJUSTING THE 45° GRINDING WHEEL FOR JOLLY CUTS/BEVELLING	20/44-4
4.3	BLOCKING OF MATERIAL	21/44-4
4.4	COMPLY WITH THE FOLLOWING WARNINGS FOR ALL PROFILING TYPES	22/44-4
4.5	HALF-BULLNOSE SHAPING	23/44-4
4.6	PERFORMING JOLLY CUTS (MITERING 45°) AND BEVELLING	24/44-4
4.7	GRINDING EDGES	24/44-4
4.8	SEQUENCE OF WHEELS	26/44-4
4.9	COMBINATION OF DIFFERENT MACHINES	28/44-4

### CHAPTER 5 MAINTENANCE INTERVENTIONS

5.1	CLEANING THE MACHINE	29/44-5
5.2	TANK EMPTYING AND CLEANING	29/44-5
5.3	SLIDING DEVICE REPLACEMENT	30/44-5
5.3.1	ADJUSTING THE SLIDING DEVICE	30/44-5
5.4	REPLACING THE GRINDING WHEEL	31/44-5
5.4.1	SHARPENING THE GRINDING WHEEL	32/44-5
5.5	STARTER REPLACEMENT	32/44-5
5.6	RECYCLE PUMP REPLACEMENT	33/44-5
5.7	STARTER OR THERMAL RELAY REPLACEMENT	34/44-5

### CHAPTER 6 ACCESSORIES

6.1	ACCESSORIES	35/44-6
6.2	SET-SQUARES	35/44-6
6.3	TUBULAR JUNCTION	35/44-6

### CHAPTER 7 DIAGNOSTICS

7.1	TROUBLE-SHOOTING	36/44-7
-----	------------------	---------

### CHAPTER 8 SPARE PARTS AND ELECTRIC DIAGRAM

8.1	SPARE PARTS	38/44-8
8.2	ELECTRIC DIAGRAMS	42/44-8

## 1.1 Declaration of conformity



The RAIMONDI S.p.A. company, with headquarters in Modena, Italy, Via dei Tipografi 11, represented by Mr. Ivan Raimondi as Legal Representative, declares under its sole responsibility that the machine named BIBULLDOG ADV, this declaration refers to, complies with the law provisions transposing the following Directives:

98/37/EEC	Machinery Directive
73/23/EEC	Low voltage Directive
89/336/EEC	Electromagnetic compatibility Directive
92/59/EEC	Directive on general product safety
85/374/EEC	Directive on Liability for defective products

Besides, it shall also be noted that, in the design and construction phases, the following technical standards have been complied with:

EN 12100-1	"Safety of machinery - Basic concepts, general principles for design: Terminology, methodology"
EN 12100-2	"Safety of machinery - Basic concepts, general principles for design: Technical principles"
EN 294	"Safety of machinery - Safety distances to prevent danger zones being reached by the upper limbs"
EN 418	"Emergency stop equipment"
EN 349	"Safety of machinery - Minimum gaps to avoid crushing of parts of the human body"
EN 1050	"Safety of machinery - Principles for risk assessment"
EN 842	"Safety of machinery - Visual danger signals - General requirements, Design and Testing"
EN 981	"Safety of machinery - System of auditory and visual danger and information signals"
EN 1037	"Safety of machinery - Prevention of unexpected start-up"
EN 811	"Safety of machinery - Safety distances to prevent danger zones being reached by the lower limbs"
EN 894-1	"Safety of machinery - Ergonomics requirements for the design of displays and control actuators Part 1: general principles for human interactions with displays and control actuators"
EN 894-2	"Safety of machinery - Ergonomics requirements for the design of displays and control actuators Part 2: Displays"
EN 894-3	"Safety of machinery - Ergonomics requirements for the design of displays and control actuators Part 3: Control actuators"
EN 953	"Safety of machinery - General requirements for the design and construction of fixed and movable guards"
EN 60204-1	"Electrical equipment of machines"
UNI EN 12418	"Masonry and stone cutting-off machines for job site. Safety"

Modena 17/10/2008

Mr. Ivan Raimondi  

## 1.2 Testing, warranty and responsibility

### Testing

The whole machine is sent to the customer ready for the installation, after passing the tests provided for by the manufacturer, in compliance with the laws in force.

### Warranty

During the 12-month warranty, RAIMONDI S.p.A. undertakes to supply, free of charge, those parts of its production found to be defective, in terms of material or processing.

Such parts will have to be returned to RAIMONDI S.p.A., shipped carriage free.

By warranty, we mean supply of defective parts, if any.

The warranty does not cover all the expenses as to travel, board, lodging, transport and manpower concerning the replacement of parts by the RAIMONDI S.p.A. technicians, which will be charged entirely on the Customer.

The warranty does not cover all the parts subject to wear.

As to purchased components, the supplier warranty will apply.

No compensation will be granted for expenses, damages or loss of profits incurred by customer.

Installation of purchased parts not complying with the specifications of RAIMONDI S.p.A., if purchased or not supplied by RAIMONDI S.p.A., if manufactured by it, as well as improper use of the machine, will make the warranty null and void.

### Responsibility

RAIMONDI S.p.A. is in no case responsible for operation anomalies or generic failures, caused by unauthorized use of the machine or by interventions and/or modifications carried out by external persons not authorized by RAIMONDI S.p.A. itself.

## 1.3 Environmental conditions

The environmental working conditions of the machine shall comply with the following indications:

Temperature	+10°C ÷ +55°C (50°F ÷ 131°F)
Humidity	10% ÷ 90% (not condensed)



**THE MACHINE SHALL BE POSITIONED IN PREMISES PROPERLY PROTECTED FROM THE RAIN.**

Environmental conditions other than those specified herein can cause serious damage to the machine and, in particular, to the electrical equipments.



**POSITIONING THE MACHINE IN ENVIRONMENTS NOT COMPLYING WITH THE INDICATIONS HEREIN WILL MAKE THE WARRANTY NULL AND VOID.**

Storage of the machine, while not working, allows for a temperature variation ranging between -10°C (14°F) and +70°C (158°F), all the other precautions still valid.



**USE IN ENVIRONMENTS WITH EXPLOSIVE ATMOSPHERE OR FIRE RISK IS STRICTLY FORBIDDEN.**

## 1.4 Intervention request - Technical Service

Each intervention request to the Technical Service shall be sent, by fax, to:

**RAIMONDI S.p.A.**

Technical Service

Telefax (39) 059 282 808

E.mail: raiutens@raimondiutensili.it

Specifying:

1. type of machine, registration number, serial number and year of production;
2. detected defects;
3. retailer where the machine was bought;
4. receipt for item purchased certifying the date of purchase by the user.

## 1.5 Spare parts orders

Each request of spare parts shall be sent, by fax, to:

**RAIMONDI S.p.A.**

Technical Service

Telefax (39) 059 282 808

E.mail: raiutens@raimondiutensili.it

specifying:

1. Machine model;
2. Registration number (see manual title page);
3. Code of the part to be ordered (see spare parts manual enclosed);
4. Requested quantity;
5. Shipping modality.

## 1.6 Marking

The machine identification data are engraved on the plate and shall always be indicated on every communication document exchanged between the user and the manufacturing company, for example in every assistance request or request of spare parts, etc.

The identification plate is placed on the machines.



**REMOVING OR TAMPERING WITH THE IDENTIFICATION PLATE IS STRICTLY FORBIDDEN.**



## 2.1 Safety general rules



**THE RULES LISTED BELOW SHALL BE CAREFULLY READ AND SHALL BECOME THE CORE OF THE DAILY PRACTICE IN THE OPERATION AND MAINTENANCE OF ALL THE EQUIPMENT, WITH A VIEW TO PREVENTING ANYTYPE OF INJURY TO PEOPLE AND/OR DAMAGING OF OBJECTS.**

1. Do not try to start the machine until its operation has been fully understood.
2. In case of doubts, despite having carefully and entirely read this manual, please contact the RAIMONDI S.p.A. Technical Service.
3. Make sure all the personnel involved in the use of the machine are made aware of all the safety-related instructions.
4. Before starting the machine, the operator shall verify the possible presence of visible defects on the safety devices and on the machine. In this case, immediately inform RAIMONDI S.p.A. or the closest Technical service Centre on every evident breaking.
5. Never start the machine until all the personnel in the areas surrounding the machine have been warned and moved away.
6. Daily check the correct operation of all the safety devices and switches.
7. Safety devices shall never be removed nor made ineffective.
8. During maintenance, adjustment or repair interventions, it might be necessary to disable some of the safety devices. This operation shall be carried out by authorized personnel only.
9. All the plates and signs applied on the machine shall be kept in perfect conditions. In case of damage, they shall be promptly replaced.
10. The operator shall be familiar with the function and position of the **STOP** and **START** buttons.
11. Replace parts deemed to be broken with original spare parts, warranted by the manufacturing company.
12. Never try reckless solutions!
13. Any intervention on live parts shall be carried out by authorized personnel only, who will have to operate exclusively with the machine disconnected from the mains.
14. Do not make any joint in the electrical connections of electric circuits.
15. Never intervene on moving parts, not even to unblock a jam.
16. Do not wear clothes, ornaments or accessories that might get entangled in the moving members.
17. Keep the area surrounding the machine clear.
18. Always wear protective glasses, hearing protectors and any other personal protection equipment in the areas where such equipment is required.
19. Always pay the greatest attention to all the warning and danger signs placed on the machine.
20. Always comply with and ensure compliance with the safety rules; in case of doubts, please consult this manual again before taking any action.
21. The machine shall be used exclusively for the uses it was intended for and in compliance with the provisions set forth in the contract with **RAIMONDI S.p.A.**



**DO NOT USE THE MACHINE FOR USES OTHER THAN THOSE INDICATED IN THIS MANUAL. DO NOT HANDLE PRODUCTS OTHER THAN THOSE INDICATED IN THE MANUAL. DO NOT INCREASE THE MACHINE SPEED BEYOND THE VALUE INDICATED IN THE MANUAL.**

Improper use of the machine can cause dangers for the personnel in charge of the machine operation and damage the machine itself.

For any problem that might arise during the machine life, and in any case not included in this manual, please contact our **Technical Service**, with a view to solving the problem in the shortest time possible.

## 2.2 Definition of safety-related terms

In this manual, the following terms will be employed as to safety:

<b>Dangerous area</b>	each area within and/or close to the machine, where the presence of an exposed person constitutes a risk for the safety and health of this person.
<b>Exposed person</b>	anybody standing, either partially or totally, in a dangerous area.
<b>Operator</b>	person in charge of the installation, operation, adjustment, maintenance, cleaning, repair, transport of parts of the machine and all the other activities required for its operation.
<b>Safety component</b>	component specifically designed by the manufacturer and sold separately from the machine, aimed at ensuring safety. Consequently, the device whose failed operation jeopardizes the safety of exposed persons will be considered as a safety component.

## 2.3 Correct use of the machine

BIBULLDOG ADV profiling machine is suitable for profiling edges on single- and double-fired ceramic tiles, porcelain gres, marble, natural stone, Tuscan terracotta tiles, cement agglomerates.



**THE MACHINE CANNOT BE USED FOR OTHER TYPES OF PRODUCTS WITHOUT PREVIOUS AUTHORIZATION BY RAIMONDI S.P.A., WHICH WILL NOT BE HELD RESPONSIBLE FOR DIRECT OR INDIRECT DAMAGE DERIVING FROM AN IMPROPER USE OF THE MACHINE.**

### Use

The machine is semi-automatic, the material feeding is set by human strength and so its feeding speed will have to be proportional to the hardness and thickness of the material to be profiled.

The cutting of materials shall always be made with sharp grinding wheels and clean water, which shall always be present in the tank in the required quantity.



**THE MACHINE CANNOT BE USED FOR DRY PROFILING OR WITH INEFFECTIVE GRINDING WHEELS.**

## 2.4 Characteristics of the machine

### Type of grinding wheels to be used

A series of grinding wheels, suitable for the BIBULLDOG ADV machine, have been designed.

Diamond grinding wheel characteristics:

External diameter	115 mm - 160 mm (4 1/2" - 6 5/16")
Hole diameter	20 mm (25/32")
Maximum shaping thickness	30 mm (1 3/16")
Direction of rotation	Counterclockwise
Rotation speed	rpm <sup>-1</sup> 4300

Types of allowed grinding wheel are defined below:

<b>DIAMOND GRINDING WHEEL</b>	<b>MEASUREMENT UNIT</b>	<b>RADIUS</b>	<b>RECOMMENDED FOR</b>
	(mm) (inches)	8 / 10 / 15 / 20 / 30 5/16" / 3/8" / 19/32" / 25/32" / 1 3/16"	HALF-BULLNOSE SHAPING
	(mm) (inches)	8 / 10 / 15 / 20 / 30 5/16" / 3/8" / 19/32" / 25/32" / 1 3/16"	HALF-BULLNOSE GRINDING / FINISHING
	(mm) (inches)	8 / 10 / 15 / 20 / 30 5/16" / 3/8" / 19/32" / 25/32" / 1 3/16"	BULLNOSE POLISHING
	(mm) (inches)	V 45° H 15 H 19/32"	JOLLY CUT / BEVELLING / MITERING 45°
	(mm) (inches)	90° H 16 / 30 H 5/8" / 1 3/16"	GRINDING
	(mm) (inches)	90° H 38 H 1 1/2"	POLISHING



**ALL RESPONSIBILITY WILL BE DECLINED IF NON-ORIGINAL GRINDING WHEELS ARE USED.**



## Technical characteristics

The BIBULLDOG ADV characteristics are outlined below:

<b>Model</b>	<b>Bibulldog ADV</b>	
Unladen mass ( <i>transport</i> )	kg	120
	U.S. lb t	264
Mass - running ( <i>driving</i> )	kg	143
	U.S. lb t	315
Mass - running ( <i>stationary</i> )	kg	133
	U.S. lb t	293
Tank capacity	Lt	23
	U.S. gal	6,1
Maximum shaping thickness	30 mm (1 3/16")	
Maximum shaping size (leght)	120 cm (47 1/4")	

## Technical characteristics of the different motors

The characteristics of BIBULLDOG ADV are listed below:

PHASE	VOLTAGE	CYCLES	POWER	RPM	ABSPORTION
SINGLE-PHASE	230 V	50 / 60 Hz	1,1 Kw (x2)	2800 - 3360	9,5 A
SINGLE-PHASE	110 V	50 / 60 Hz	1,1 Kw (x2)	2800 - 3360	17,8 A

## 2.5 Description of machine groups

The BIBULLDOG ADV series are made up of a series of groups. These interact to ensure functions are always effective. The groups are:

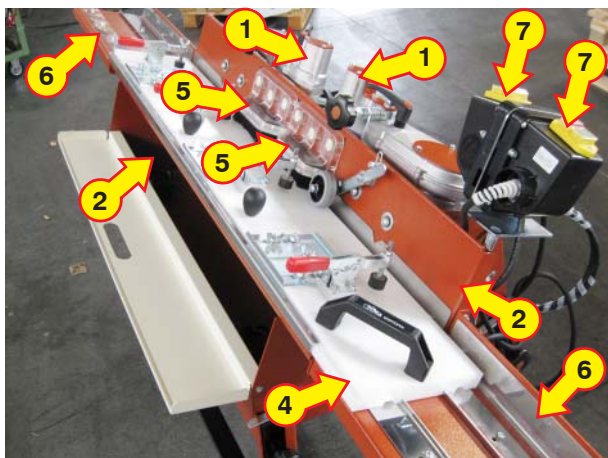

### 1 Motor group

On which the grinding wheel is positioned. It is equipped with adjustment knobs and handles.

### 2 Cooling group

It allows for the constant supply of cooling water for cutting, equipped with submersible pump and adjustment valve.

### 3 Frame

It is the load-bearing part of the machine, equipped with telescopic feet to ease transport on a vehicle. A series of wheels, positioned on the rear side, allows for quick and easy handling in the working area. It is equipped with sliding guides for the trolley.

### 4 Trolley

Equipped with pressing devices to block the material and with movable fences to prevent it from sliding.

### 5 Protection device

### 6 Extensions

### 7 Starting device

## 2.6 Position of the operator



The BIBULLDOG ADV series shall be used by one single operator, who will have to stand sideways the machine and, by grabbing the trolley handle, will be able to make half-bullnose shapings, bevels and “jolly” (45° mitering) cuts in safe conditions and unstressfully.

During the working phase, the operator shall always stand in the front part and grab the trolley handles with both hands.

The material shall always be leaned against the reference strikers and well-clamped under the pressing devices.



### **CUTTING DANGER.**

**THE MACHINE SHALL BE TURNED ON EXCLUSIVELY WHEN THE OPERATOR IS IN THE WORKING POSITION.**

**THE MACHINE SHALL BE TURNED OFF AT THE END OF EACH CUTTING OPERATION.**

**GETTING THE HANDS CLOSE TO THE GRINDING WHEEL WHILE IT IS RUNNING IS STRICTLY FORBIDDEN.**

## 2.7 Safety devices

The BIBULLDOG ADV series is equipped with the following safety devices:

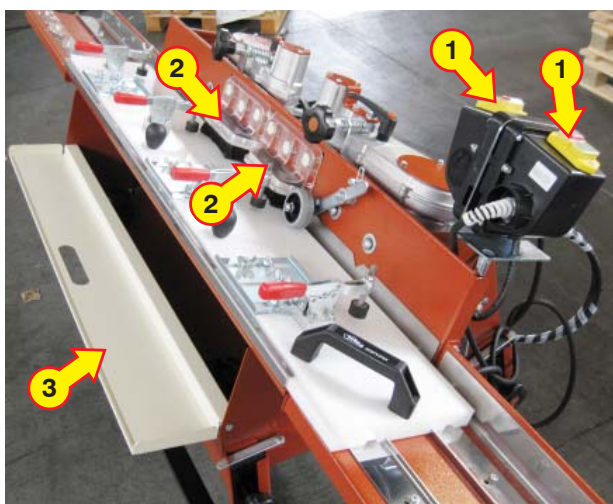

### **1 ON/OFF switch**

It allows for the start and stop of the machine. In case of potential danger, the machine shall be turned off by means of the red OFF switch.

### **2 Tool guard**

It prevents process water and debris from coming out of the cutting area.

### **3 Front door**

It prevents water and debris, caused by cutting, from coming out of the machine area.



**RAIMONDI S.P.A. WILL NOT BE HELD RESPONSIBLE FOR DAMAGE CAUSED BY EJECTIONS RESULTING FROM SCARCE MAINTENANCE OF OR TAMPERING WITH THE GUARDS, OR FROM AN ERRONEOUS POSITION OF THE OPERATOR (SEE PICTURE SHOWING THE POSITION OF THE OPERATOR).**

## 2.8 Accessories of the machine

The BIBULLDOG ADV series is supplied with the following accessories:



1. 30 mm (1 3/16") hexagon wrench;
2. 8 mm (5/16") socket head screw;
3. 80 cm (31 1/2") trolley for sizes up to 12 cm (4 3/4") of width;
4. 80 cm (31 1/2") trolley for sizes exceeding 12 cm (4 3/4") of width;
5. Dressing grinding wheel and stone holder;
6. Two extensions for sliding plane;
7. Striking plate;
8. Use and maintenance manual in the relative language.

## 2.9 Noise

The machine was designed and manufactured in such a way as to reduce at source the machine noise level. Obviously, sound pressure varies in relation to the type of blade, its wear status and the material to be cut; hence, we have made a series of measurements using different types of blades and different materials, both indoors and outdoors.

Measurements made in the operator position on a similar machine have provided the following values, where:



The weighted continuous equivalent sound pressure level A1 [ $L_{Aeq} = \text{dB(A)}$ ] Outdoor measurements

<b>Type of grinding wheel</b>		<b>Type of material</b>		
		Hollow	Porcelain	Stone
	Continuous	68,8	93,0	88,8
	Segmented	83,1	106,2	102,3

Weighted continuous equivalent sound pressure level A1 [ $L_{Aeq} = \text{dB(A)}$ ] Indoor measurements

<b>Type of grinding wheel</b>		<b>Type of material</b>		
		Hollow	Porcelain	Stone
	Continuous	75,5	97,5	95,8

Weighted maximum instant sound pressure level C1 [ $L_{pC} = \text{dB(C)}$ ] Outdoor measurements

<b>Type of grinding wheel</b>		<b>Type of material</b>		
		Hollow	Porcelain	Stone
	Continuous	71,6	96,7	92,4
	Segmented	86,4	110,4	106,4

The conditions for indoor measurements are the following:

Building size:	
length	8 m (26')
width	5 m (16')
height	3 m (10')
Type of premises:	
floor	polished concrete
covering	tile
walls	masonry with side glass
Instrument used	Bruel & Kjaer mod. 2221 class 1
Reference standard	DIN 45635

The use of the machine is only allowed provided that suitable hearing protection is ensured. The employer shall hence compulsorily provide the operators with personal protection equipment (earphones, plugs).

## 2.10 Vibrations

The machine was designed to minimize the effects generated by vibrations. In any case, these are associated to relevant factors, such as the type of material to be cut and wear of the disc.

The results of the measurements carried out in the field, implementing UNI EN ISO 8662-12:1999, are the following:

Handle		Linear values (0 = n.a.)					
A lin x	16,0	m/sec <sup>2</sup>					
A lin y	16,5	m/sec <sup>2</sup>					
A lin z	12,2	m/sec <sup>2</sup>					
A (lin) sum	26,4	m/sec <sup>2</sup>					
		Weighted values ISO 5349/2001 (0 = n.a.)					
A lin x	1,5	m/sec <sup>2</sup>					
A lin y	1,8	m/sec <sup>2</sup>					
A lin z	1,3	m/sec <sup>2</sup>					
A (lin) sum	2,7	m/sec <sup>2</sup>					
		A (8) (m/sec <sup>2</sup> )					
1,0	1,4	1,7	1,9	2,1	2,3	2,5	2,7
1	2	3	4	5	6	7	8
		Exposure time (hours)					

### Formula to calculate the level of daily exposure to vibrations - A(8)

For the comparison with exposure limit values and action values, the total weighted acceleration, obtained through the vector sum of the components, shall be standardized, namely analytically referred to a reference time of 8 hours.

$$A(8) = A_{(w) \text{ sum}} \sqrt{\frac{T}{T_0}}$$

where, in line with the standard adopted symbols:

- $A_{(w)sum}$  It is the total acceleration, sum of the three axial components.
- $A(8)$  It is the weighted equivalent acceleration for 8 hours.
- $T$  It is the overall acceleration exposure time -  $A_{(w)sum}$
- $T_0$  It is the reference time (8 hours, equal to 480 minutes or 28800 seconds).

In the overall assessment, non-continuous use caused by time fragmentation for material positioning and removal thereof once split up shall be taken into account. RAIMONDI S.p.A. believes BIBULLDOG ADV shall be included in the group of machines not exceeding the limit values provided for by the Directive 2004/44/EC.

If during the working day the operator foresees several exposures to vibrations of different origin and entity (as for the use of several vibrating equipments), the parameter  $A(8)$  will have to be calculated as weighted sum of the different contributions:

$$A(8) = \sqrt{\frac{1}{T_0} \sum_{i=1}^n A_{(w)sum,i}^2 \cdot T_i}$$

where:

- $A_{(w)sum,i}$  It is the total acceleration of the i-th operation.
- $T_i$  It is the overall acceleration exposure time -  $A_{(w)sum,i}$

Consequently, in this case, the employer shall compulsorily provide the operator with the protection devices set forth in the Legislative Decree 187/05 in relation to the values of the standardized daily personal exposure level  $A(8)$ .

## 2.11 Demolition and disposal

The manufacturer estimates a life of 15.000 hours of operation under normal conditions of use.

At the end of the life cycle, the company using the machine shall see to the demolition of the machine in compliance with the laws in force, first of all seeing to the emptying of lubricant fluids and overall cleaning of the different elements and, subsequently, separation of the parts making up the machine.

After disassembling the machine in line with the previous disassembling procedure, the different materials shall be separated in compliance with the laws of the country where the machine shall be eliminated. The machine does not contain harmful components or substances requiring particular removal procedures.



**DURING THE DISPOSAL PROCESS, COMPLIANCE WITH THE LAWS IN FORCE IN THE COUNTRY IS REQUIRED.  
POLLUTANTS, SUCH AS OILS AND SOLVENTS, SHALL BE STORED EXCLUSIVELY IN METAL DRUMS.**

## 2.12 CE Manufacturer's declaration

**DIRECTIVE 2002/95/EC** (RoHS Directive) of the European Parliament and of the Council of 27 January 2003 on the restriction of the use of certain hazardous substances in electrical and electronic equipment.

**DIRECTIVE 2002/96/EC** (WEEE Directive) of the European Parliament and of the Council of 27 January 2003 on waste electrical and electronic equipment.

With reference to the Directives in question, and in particular to the ANNEXES "I A" and "I B" of the Directive 2002/96/CE, RAIMONDI S.p.A., declares that its product.

### **DOES NOT FALL IN THE FIELD OF APPLICATION OF THE DIRECTIVE 2002/95/EC**

The Directive in question also provides for specific EXEMPTIONS, among which, at point 6 of the ANNEX of the Directive 2002/95/EC... 6) *Lead as an alloying element in steel containing up to 0,35 % lead by weight, aluminum containing up to 0,4 % lead by weight, and as a copper alloy containing up to 4 % lead by weight...*

The raw materials used by RAIMONDI S.p.A., for the manufacturing of its components, are comprised within such EXEMPTION limits.

All surface treatments and plastic materials, present in the RAIMONDI S.p.A. products, do not contain the forbidden substances listed in the Directive 2002/95/EC.

## 3.1 Packing transport

Transport shall be made using a fork lift truck, inserting the forks into the specific seats of the pallet. Use a lift truck having a suitable capacity (>200 Kg / 441 lbs).

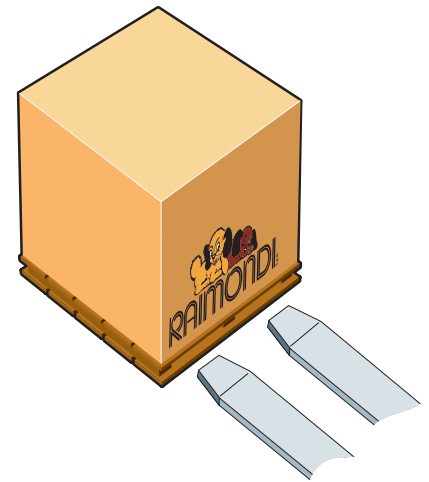

## 3.2 Manual handling

For handling exploit the lever effect, using the wheels in the rear side.



**MAKE SURE THE TROLLEY HAS BEEN REMOVED, THE TOOL BOX EQUIPPED WITH THE SPECIFIC SAFETY PIN HAS BEEN BLOCKED AND THE WATER TANK HAS BEEN EMPTIED.**



In case the machine needs to be stored during idle periods, it shall be kept in covered premises, so that the machine can be protected from bad weather, and free from aggressive chemicals .

Before storing the machine, disconnection from the mains and unloading of the cooling water tank is recommended.

The machine shall be stored in environments with adequate temperatures (from -10 to + 70°C) / (from 14° F to 158°F).

### 3.3 Power supply

The “BIBULLDOG ADV” profiling machine shall be supplied at the voltage corresponding to the value indicated on the “TECHNICAL DATA” plate, the machine shall be connected to a line only with an effective ground cable. In case of doubt, do not connect the machine. Connect the machine to a 16A socket.



**THE USE OF EXCESSIVELY LONG PATCH CORDS OR POWER SUPPLY WITH CURRENT GENERATORS, MIGHT LEAD TO THE FOLLOWING TROUBLES:**

1. SLOW STARTING OF THE MOTOR AND SAFETY DEVICES INTERVENTION;
2. MOTOR OVERHEATING WITH POWER DROP;
3. THE SWITCHING ON-OFF DEVICE DOES NOT WORK.



**IF THE MACHINE IS CONNECTED TO THE MAINS BY MEANS OF A PATCH CORD, THIS SHALL HAVE THE FOLLOWING CHARACTERISTICS:**

1. MAXIMUM LENGTH 10 METERS (33');
2. HAVING A SECTION SUITABLE FOR THE LOAD;
3. BEING COMPLETELY UNCOILED.

The “BIBULLDOG ADV” machine shall be connected to the mains equipped with a residual current circuit breaker (RCCB) or a Class II isolation transformer, having the characteristics indicated in the table:

<b>Transformer</b>	230V - 50 / 60 Hz 1,1 kW (x2)	110V - 50 / 60 Hz 1,1 kW (x2)
<b>RCCB</b>	9 / 11A Id 30mA	17 / 21A Id 30mA



**FOR THE CORRECT USE OF THE RESIDUAL CURRENT CIRCUIT BREAKERS, DO NOT FORGET TO CHECK THEIR EFFICIENCY BY MEANS OF THE TEST BUTTON PLACED ON THE FRONT PART OF THE DEVICE ITSELF.**



## 3.4 Assembly of the machine

 **TO CARRY OUT THIS OPERATION, WEAR THE PROTECTIVE GLOVES AND ACCIDENT-PREVENTION SHOES.**

Remove the machine from the pallet and make sure there are no broken or damaged parts.

 **MAKE SURE THE TOOLBOX HAS BEEN FIXED CORRECTLY.**

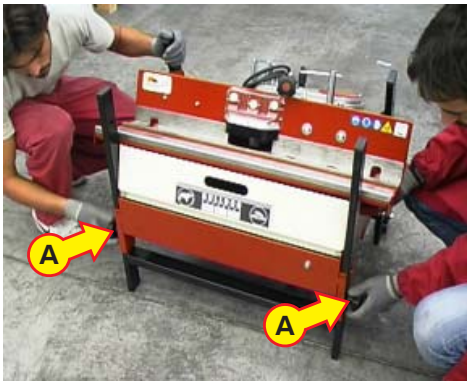

Free the front legs by completely unscrewing the leg fixing knobs (A). Go to the front side of the machine and lift it so that the leg goes past the left and right safety bars (B) and at this point close the bars.

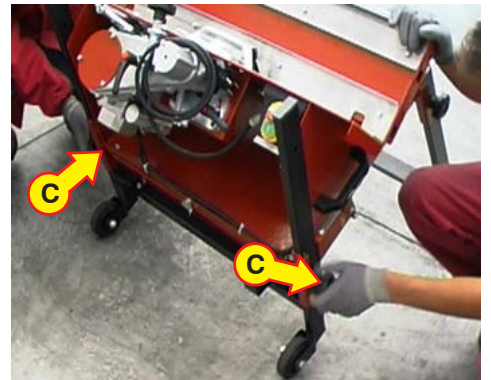

Slowly lower the machine until the leg is resting on the 2 safety bars (B) previously closed and firmly screw the leg fixing knobs (A).

Go to the rear side of the machine and completely unscrew the leg fixing knobs (C).

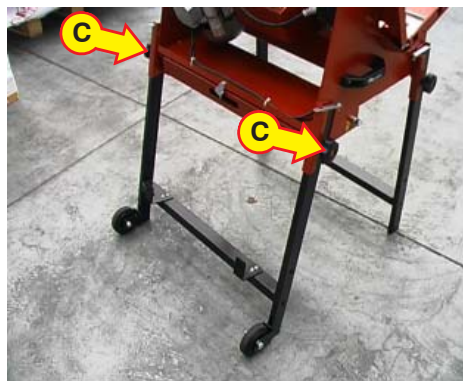

Lift the machine until the two safety bars can be inserted (B1). Lower the machine until the leg touches the safety bars (B1). Firmly screw the leg fixing knobs (C). Regulate the adjustable feet (D) to stabilize the machine.

### 3.4.1 Extensions for sliding plane

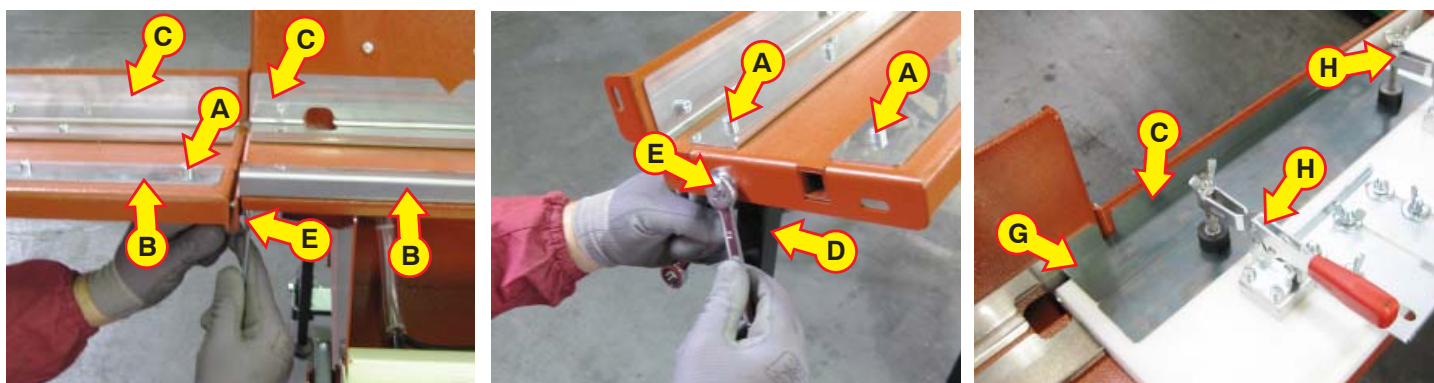

Remove the trolley from the machine. Approach extensions to the frame, fit screws (A) into their housings and clamp not completely the nuts. Mount on the extensions the supporting legs (D) and completely tighten screws (E).

To find levelness between the machine plane and the extension plane use a scale and adjust the feet. Fit the trolleys on guides. Position the striking plate (G) on the trolley plane and after checking it is leaning on the guide (C) of the machine clamp by means of clamps (H). Perfect the positioning of the extension so that by sliding the trolley the striking plate (G) keeps in contact with guides (C) of the machine and of the extensions.

Once the correct position is found clamp deeply the screws (A). Check for the correct assembly by sliding the trolley completely.

In case the trolley cannot slide loosen the screws (A) and repeat the above operations.

### 3.4.2 Tank filling



**TO CARRY OUT THIS OPERATION, MAKE SURE THE MACHINE IS NOT CONNECTED TO THE MAINS.**

After closing the drain hole with the specific plug, pour cold and clean water into the tank until a level 2 cm (3/4") above the recycle pump has been reached.

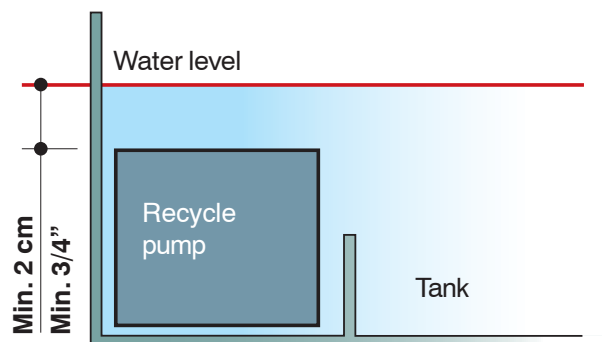

**TO ALLOW FOR THE PUMP CORRECT FUNCTIONING, WATER SHALL BE KEPT CLEAN. EACH TIME THE TANK WATER IS CHANGED, CLEAN THE FILTER AND THE PUMP IMPELLER.**



**POUR IN ENOUGH CLEAN WATER TO COVER THE PUMP.**

## 4.1 Adjusting the grinding wheel for half-round shaping

 **TO CARRY OUT THIS OPERATION, MAKE SURE THE MACHINE IS NOT CONNECTED TO THE MAINS.**

### Horizontal adjustments

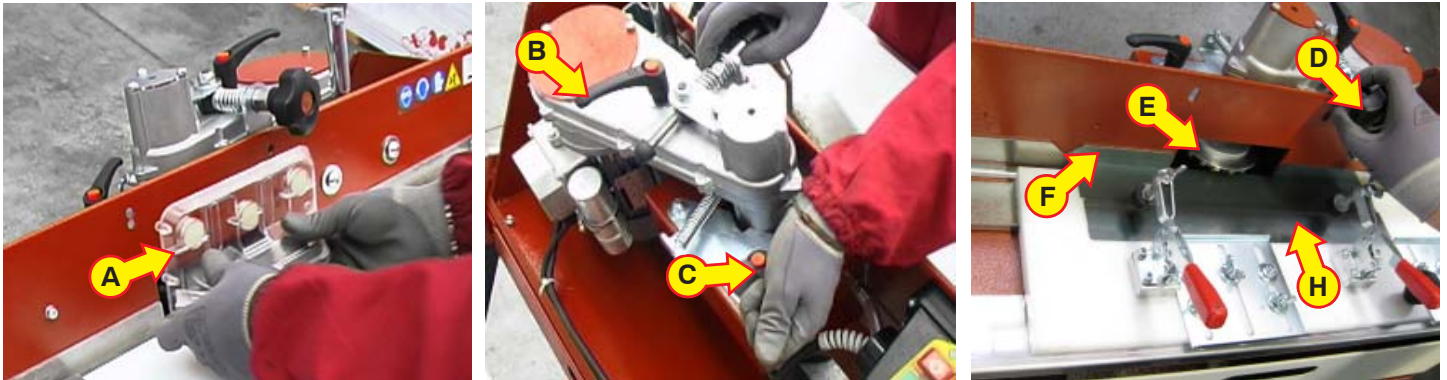

Remove the spray guard (A). Unblock the motor group by slackening the (B) and (C) handles. Position the striker (H) on the trolley base and after checking it is resting on the guides (F) block it by means of clamps (G). Screw or unscrew the knob (D), until the diamond profile (E) touches the striker (H).



### Vertical adjustments

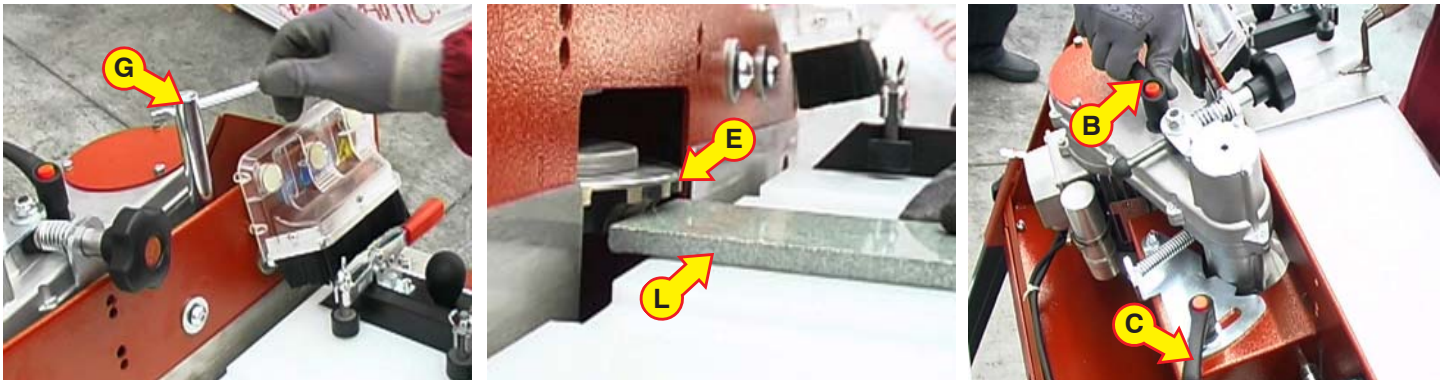

Insert the wrench (G) in the nut for vertical adjustment. Place the material to be profiled on the trolley (L). Screw or unscrew with the wrench (G) until the grinding wheel diamond rim (E) touches the material to be profiled. Block the (B) and (C) handles. Refit the spray guard (A).

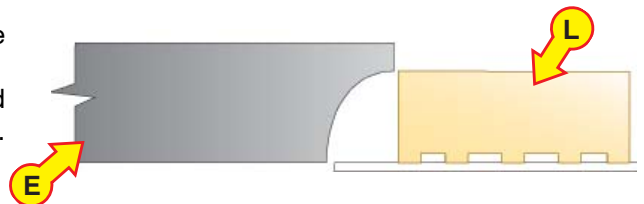

### Fine adjustments

Perform a 4 / 5 cm (1<sup>1/2</sup> / 2") chamfer and make sure the cut is as requested. If necessary make any fine adjustments, repeating the previously-illustrated steps.

## 4.2 Adjusting the 45° grinding wheel for Jolly cuts/bevelling



**TO CARRY OUT THIS OPERATION, MAKE SURE THE MACHINE IS NOT CONNECTED TO THE MAINS.**

### Adjustment for bevelling

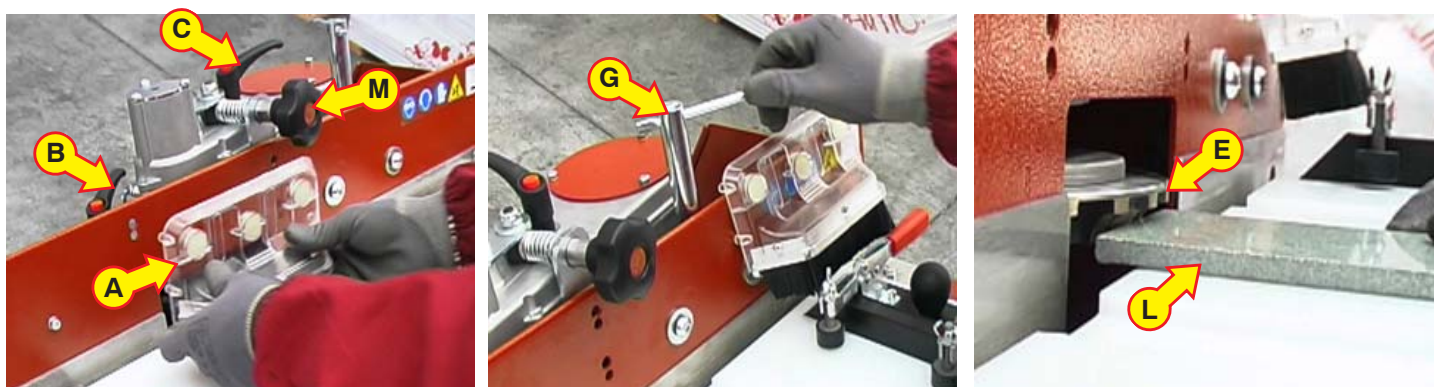

Remove the spray guard (A). Unblock the motor group by slackening the (B) and (C) handles. Insert the wrench (G) in the nut for vertical adjustment and screw until the grinding wheel height (E) slightly exceeds the thickness of the material to be bevelled. Place on the trolley the material (L) to be bevelled with the rear side leaning on the trolley. Lower the grinding wheel (E) by unscrewing with the wrench (G) until the diamond rim touches the material to be bevelled.

Remove the material (L) to be bevelled from the trolley, adjust the quantity of material to be removed using the knob (M). Block the motor group screwing again the (B) and (C) handles. Reposition the spray guard (A). Perform a 4 / 5 cm (1<sup>1/2</sup> / 2") bevelling and if necessary perfect the adjustment using the knob (M).

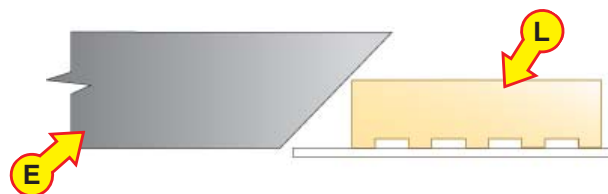

### 45° jolly (mitering) cut adjustment



Remove the spray guard (A). Unblock the motor group by slackening the (B) and (C) handles. Insert the wrench (G) in the nut for vertical adjustment and screw until the grinding wheel height (E) slightly exceeds the thickness of the material to be cut. Place the material to be cut on the trolley (L) with the glazed side leaning on the trolley. Lower the grinding wheel (E) by unscrewing by means of the wrench (G) until the diamond rim removes the desired quantity of material. Remove the material (L) to be cut from the trolley, move the grinding wheel closer by means of the knob (M) according to the quantity of material to be removed. Block the motor group by screwing the (B) and (C) handles. Reposition the spray guard (A). Perform a 4 / 5 cm (1<sup>1/2</sup> / 2") cut and if necessary perfect the adjustment by using the knob (M).

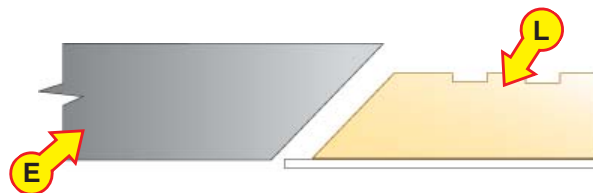

## 4.3 Blocking of material



**TO CARRY OUT THIS OPERATION, MAKE SURE THE MACHINE IS NOT CONNECTED TO THE MAINS.**

### Trolley suitable for sizes up to 12 cm (4 22/32") of width

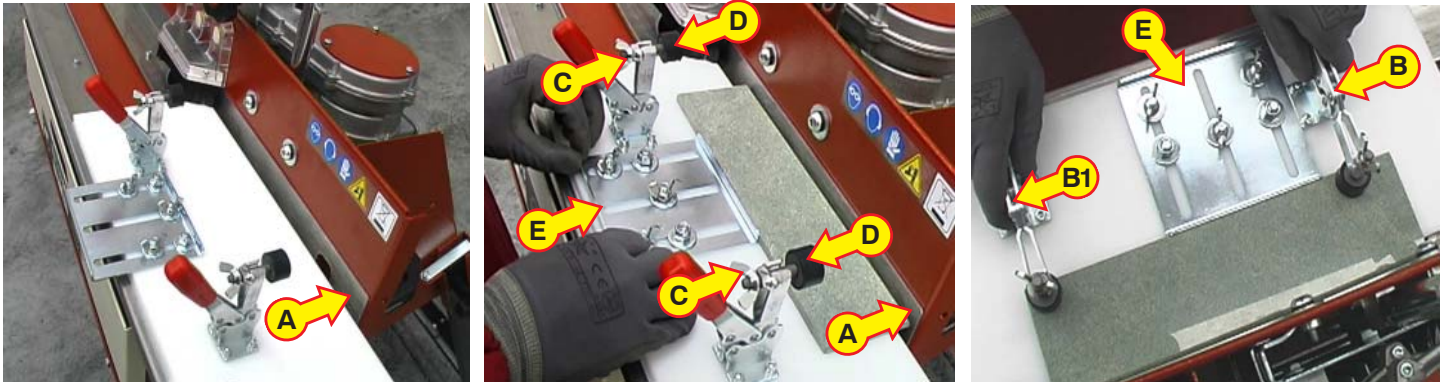

Make sure the side of the material leaning on the slide (A) is rectilinear and without irregularities. Place the material to be profiled on the trolley, perfectly leaning on the slide (A). To prevent the material from displacing, move the pins close to it (E). Block the material by means of (B) (B1) (B2) locking devices.

### Trolley suitable for sizes exceeding 12 cm (4 22/32") of width.

Make sure the side of the material leaning on the slide is rectilinear and without irregularities, place the material to be profiled on the trolley, perfectly leaning on the slide. Block the material by means of locking devices. To enhance the firmness of the material, especially for large size up to maximum width of 60 cm (23 5/8") and maximum length 80 cm (31 1/2"), it is advisable to use the optional set-square (see Chapter 6.1 "Optional accessories").



According to the thickness of the material to be profiled, the locking devices need to be adjusted, the wing nut needs to be unscrewed (C) and the pressing device to be screwed or unscrewed (D); firmly screw the wing nut (C) until the material is blocked.

 AN EXCESSIVE LOCKING DEVICE PRESSURE MAY CAUSE THE DEFORMATION OF THE TROLLEY AND JEOPARDIZE THE SLIDING MOVEMENT.

## 4.4 Comply with the following warnings for all profiling types

 BEFORE PROFILING, MAKE SURE THAT THE GRINDING WHEEL IS SHARP, PLACED IN THE CORRECT POSITION AND THAT THE MATERIAL HAS BEEN PROPERLY BLOCKED.

 BEFORE PROFILING, MAKE SURE THE KNOB AND THE HANDLE ON THE TROLLEY HAVE BEEN PROPERLY FIXED.

 THE FEEDING SPEED DURING THE PROFILING SHALL BE PROPORTIONAL TO THE HARDNESS AND THICKNESS OF THE MATERIAL TO BE PROFILED TO PREVENT THE MATERIAL FROM DISPLACING AND TO AVOID A MOTOR OVERLOAD.

IF THE PROFILING PERFORMANCE IS UNSATISFACTORY, DESPITE THE COMPLIANCE WITH ALL THE ABOVE-LISTED PROCEDURES, IT IS NECESSARY TO CHECK THE CLAMPS TIGHTNESS AND TO DRESS THE GRINDING WHEEL BY MEANS OF THE DRESSING STONE.

 AFTER YOUR WORK AND BEFORE DISENGAGING THE PIECE FROM THE CLAMPS, TURN OFF THE MACHINE BY MEANS OF THE POWER SWITCH.

 WHEN SHAPING, BEAR IN MIND THE INSTRUCTIONS GIVEN IN THE “*WORKSTATION PARAGRAPH*” (see paragraph 2.6).

## 4.5 Half-bullnose shaping



**Shaping phase (removal of the 90° angle and creation of the quarter round profile)**

**Suitable to cut bullnose up to 30 mm (1 3/16") of maximum thickness.**

- 1) Press the switch to turn on the machine.
- 2) Wait for cooling water.
- 3) Start your work grasping knob (A) with your left hand and handle (B) on the carriage with your right.
- 4) Proceed with shaping by pushing the carriage slowly forward towards the grinding wheel.
- 5) Continue the cut maintaining a constant speed.
- 6) Slow down towards the end of the cut.
- 7) If the materials is very hard or thick, repeat the shaping in 2 or 3 passes.
- 8) Every 50 linear metres (164') shaped, check condition of the grinding wheel profile.
- 9) Wear may alter the profile of the grinding wheel and lead to incorrect shaping. This will prevent correct execution of the subsequent stages of operation, namely grinding and polishing. To regenerate the grinding wheel profile, contact an authorised dealer.

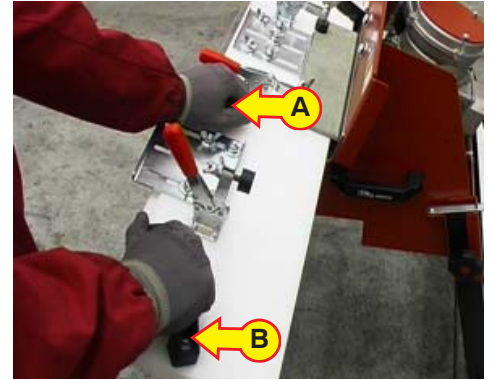

**Grinding / Finishing phase**

**To grind / finish the profile previously created with the grinding wheel:**

- 1) Use a grinding wheel with the same radius as that of the grinding wheel used for removal.
- 2) Perfect positioning of the grinding wheel so that it copies the shape previously created.
- 3) The amount of material removed should not exceed 2/10 of mm (0,008 inches).



**Polishing phase**

**Before polishing, it is essential to perform the grinding / finishing operations**

In order to maintain the grinding wheels in good working condition:

- 1) Use a grinding wheel with the same radius as that of the grinding wheel used previously for grinding / finishing.
- 2) Perfect positioning of the grinding wheel so that it copies the shape previously created.
- 3) The grinding wheel must maintain minimum contact with the material. The amount of material removed should not exceed 1/100 of mm (0,00004 inches).
- 4) Cooling water must be clean. Suspended dust resulting from the operations previously performed may damage the diamond rib.
- 5) The grinding wheel operating cycle is the following: 400 grain, 800 grain, 1500 grain, 1800 grain, 3500 grain.

**THE PASSAGE FROM A GRAIN TO ANOTHER SHALL BE GRADUAL AND COMPLY WITH THE RECOMMENDED PROCEDURE.**

## 4.6 Performing Jolly cuts (mitering 45°) and bevelling



### Removal phase

*Suitable for Jolly cutting (mitering 45°) and bevelling*

- 1) Adjust the position of the grinding wheel according to the quantity of material to remove.
- 2) If the material is very hard or thick, repeat the shaping in 2 or 3 passes.
- 3) Use of the grinding wheel in fixed position can lead to uneven wear of the diamond rib and streaking on its surface. To prevent this inconvenience occurring, change the position of the grinding wheel.

## 4.7 Grinding edges



### Removal / Grinding phase

*Suitable for removing / grinding edges up to 30 mm (1 3/16") thick.*

- 1) Adjust the position of the grinding wheel according to the quantity of material to remove.
- 2) If the material is very hard or thick, repeat the shaping in 2 or 3 passes.
- 3) Use of the grinding wheel in fixed position can lead to uneven wear of the diamond rib and streaking on its surface. To prevent this inconvenience occurring, change the position of the grinding wheel.

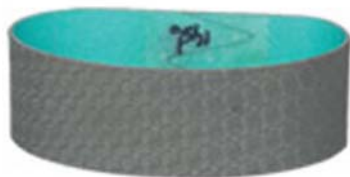

### Finishing phase

*Suitable for finishing edges up to 30 mm (1 3/16") thick.*



To finish the edge previously machined with the grinding wheel for removal:

- 1) Fit the 100 grain diamond belt on the rubber expander.
- 2) Adjust the position of the belt to obtain minimal contact with the edge.
- 3) The amount of material removed should not exceed 2/10 of mm (0,008 inches).
- 4) Use of the belt in fixed position can lead to uneven wear of the diamond rib and streaking on its surface. To prevent this inconvenience occurring, change the position of the belt.





#### Polishing phase

**Suitable for polishing edges up to 30 mm (1 3/16") thick.**



**BEFORE POLISHING, IT IS ESSENTIAL TO PERFORM THE GRIND-ING/POLISHING OPERATIONS.**

To keep the belt in good working order:

- 1) Adjust the position of the diamond belt for complete (but minimal) contact with the edge.
- 2) The amount of material removed should not exceed 1/100 of mm (0,00004 inches).
- 3) Cooling water must be clean. Suspended dust resulting from the operations previously performed may damage the diamond belt.
- 4) The belt operating cycle is the following: 400 grain; 800 grain.
- 5) Final polishing with a 800 grain belt can only be performed after pre-polishing with a 400 grain belt.
- 6) Use of the belt in fixed position can lead to uneven wear of the diamond rib and streaking on its surface. To prevent this inconvenience occurring, change the position of the belt (*see paragraph "4.2 Adjusting the 45° grinding wheel for jolly cuts/bevelling"*).

## 4.8 Sequence of wheels

**! IN CASE A SINGLE TOOL IS TO BE USED, THE SECOND TOOL HAS TO BE ADJUSTED TO PREVENT ITS INTERFERENCE WITH THE MATERIAL TO BE PROFILED.**

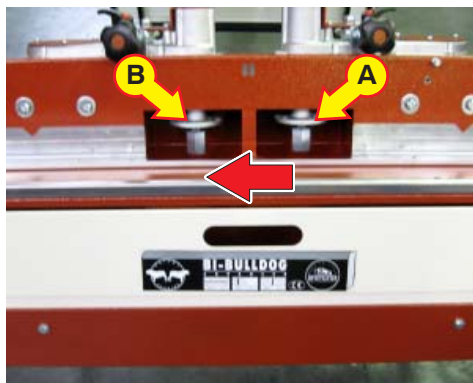

The Bibulldog ADV profiling machine is equipped with two motor groups (A) and (B) in series to allow execution of two different processing phases in a single pass.

### Profiling

To profile materials having high thickness or being very hard we suggest to carry out profiling using two wheels to be adjusted at two different heights.

The first wheel is 'high' and carries out a partial profiling the second wheel is 'low' and completes the profiling.

**THE AMOUNT OF MATERIAL PROFILED IN THE DIFFERENT PASSES HAS TO BE THE SAME.**

### 45° jolly cut





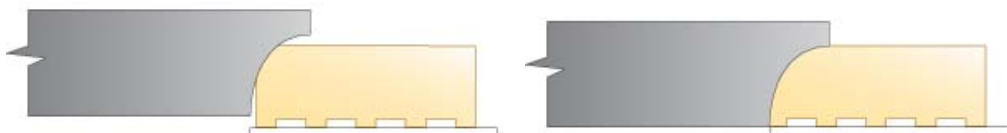

### Semi round cut



Possible combinations

WHEEL (A)	WHEEL (B)
 <p><i>PROFILING</i></p>	 <p><i>FINISHING</i></p>
 <p><i>POLISHING GR.400</i></p>	 <p><i>POLISHING GR.800</i></p>
 <p><i>POLISHING GR.1500</i></p>	 <p><i>POLISHING GR.1800</i></p>

WHEEL (A)	WHEEL (B)
 <p><i>PROFILING</i></p>	 <p><i>BAND GR.100</i></p>
 <p><i>BAND GR.400</i></p>	 <p><i>BAND GR.800</i></p>

## 4.9 Combination of different machines

The Bibulldog ADV series was conceived to be modular and to combine different machines belonging to the same series or to the Bulldog series.

**FOR THIS OPERATION THE JUNCTION ACCESSORY IS NECESSARY (see chapter optional accessories).**

**To combine one or more machines comply with the following:**

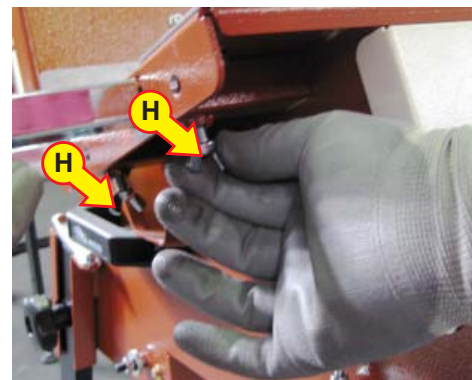
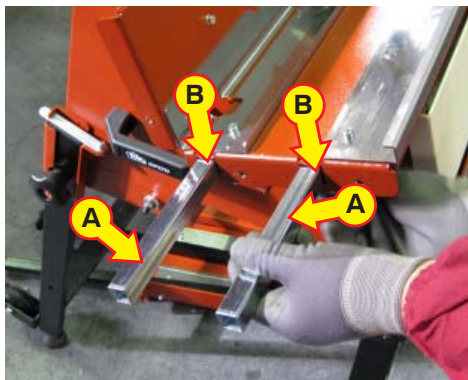

Remove any extension. Fit the tubular junctions (A) into a machine through the relevant slots (B) making them project of 10 cm (4"). Block the tubular junctions by means of wing nuts (H).

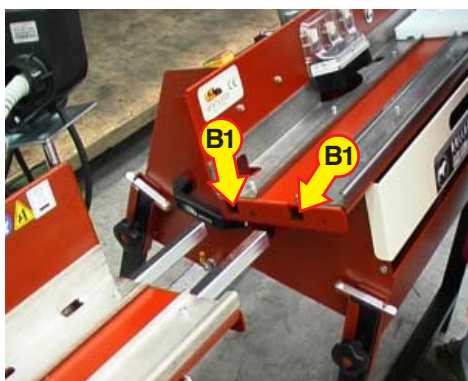

Approach the two machines and by means of the adjustable feet (C) make them reach the same height until the two previously inserted tubular junctions (A) are in line with the slots (B1) of the second machine. Fit the second machine into the two previously mounted tubular junctions of the former machine, until both frames come into contact.

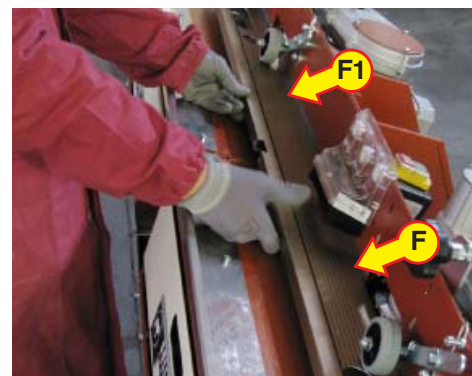
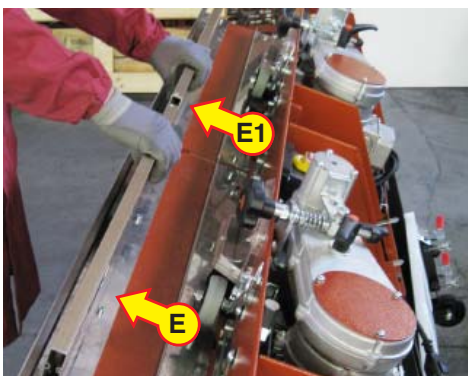

Insert the junction bolts (D) in the holes (G) screw the nuts without tightening them completely. By means of an aluminium rule check the planarity of the tables (E - E1) and of sides of the 2 machines (F-F1); perfect the alignment using the adjustable feet. Make sure the trolley slides properly in both directions. Tighten the junction bolts (D) and make sure the alignment of the two machines has not altered. Then tighten the wing nuts. (G). Reassemble any extension (see chapter 6.2 Extensions for the sliding surface).

### 5.1 Cleaning the machine

 TO CARRY OUT THIS OPERATION, MAKE SURE THE MACHINE IS NOT CONNECTED TO THE MAINS.

 NEVER USE BLASTS OF WATER. INSTEAD USE A DAMP SPONGE. KEEP THE CARRIAGE GUIDE CLEAN (DO NOT USE GREASE).

 TO CARRY OUT THIS OPERATION, WEAR THE PROTECTIVE GLOVES AND ACCIDENT-PREVENTION SHOES.

#### Lubrication



#### Grease, on a regular basis:

- The grinding wheel holder in the point where the flange/chuck come into contact.
- the vertical adjustment guide.

### 5.2 Tank emptying and cleaning

 TO CARRY OUT THIS OPERATION, MAKE SURE THE MACHINE IS NOT CONNECTED TO THE MAINS.

 TO CARRY OUT THIS OPERATION, WEAR THE PROTECTIVE GLOVES AND ACCIDENT-PREVENTION SHOES.

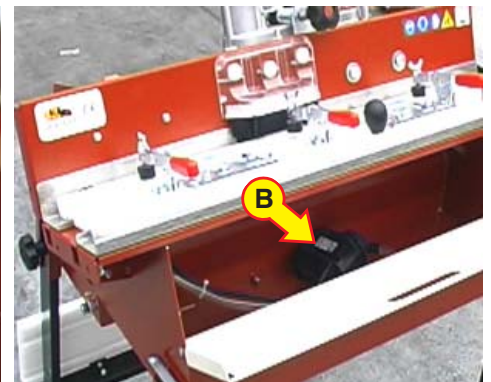

Place a bucket underneath the tank, close to the drain hole. Remove the plug (A) and let dirty water outflow. Remove the pump (B) from the tank. Then clean the tank thoroughly.

 DISPOSAL OF WATER CONTAINED WITHIN THE TANK SHALL BE MADE IN COMPLIANCE WITH THE LAWS IN FORCE IN THE COUNTRY OF USE.

 FOR A CORRECT OPERATION OF THE PUMP, WATER SHALL BE KEPT CLEAN.  
UPON EACH TANK WATER CHANGE, CLEAN THE FILTER AND THE PUMP ROTOR.

## 5.3 Sliding device replacement

**! TO CARRY OUT THIS OPERATION, WEAR THE PROTECTIVE GLOVES AND ACCIDENT-PREVENTION SHOES.**

In case the sliding guides wear out, comply with the following:

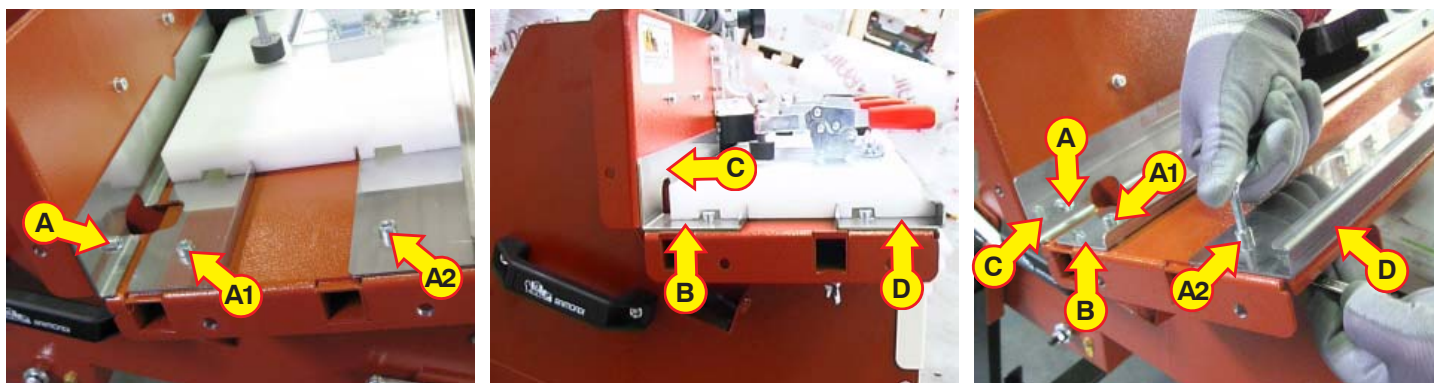

Unscrew all the (A) (A1) and (A2) screws. Remove the guides (B) (C) (D). Clean thoroughly the machine surfaces. Position the new guide (B), push it towards the tool and tighten the screws, but not completely (A1). Place the new guide (C) so that it adheres to the surface and fix it, clamping the screws completely (A). Then position the guide (D) and tighten the screws, but not firmly (A2).

### 5.3.1 Adjusting the sliding device

**! TO CARRY OUT THIS OPERATION, WEAR THE PROTECTIVE GLOVES AND ACCIDENT-PREVENTION SHOES.**

If you notice that the carriage features excessive clearance, proceed as follows:

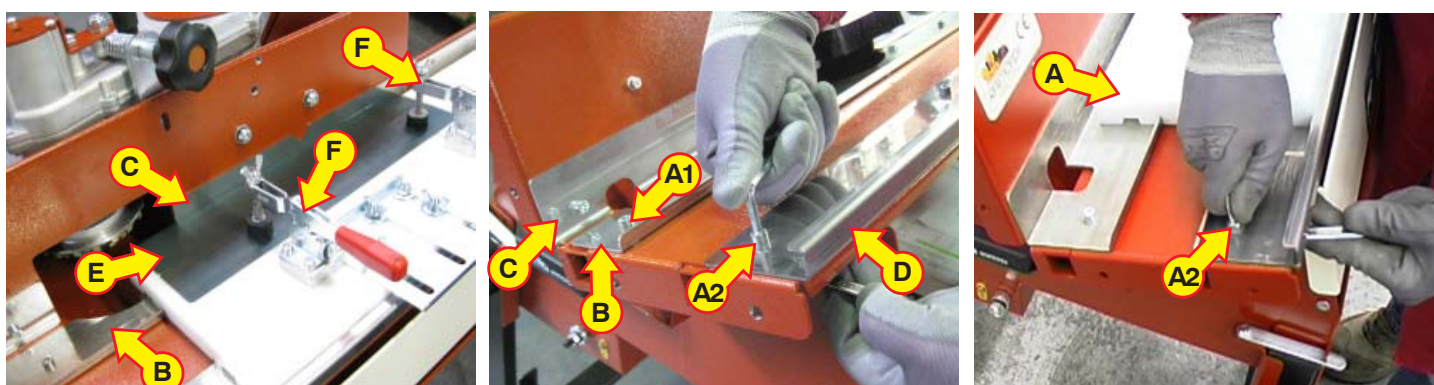

Insert the trolley (A) on the guides. Position the striker (E) on the trolley surface and after checking it is leaning on the guide (C) tighten it with the clamps (F). Make the trolley slide and perfect the guide position (B) so that the striker (E) keeps touching the guide (C). Once the right position is found, firmly tighten the screws (A1), the ones at the guide end first and then the central two. Push the guide (D) towards the trolley edge, leaving room (0,5 mm / 0,02 inches) between the guide and the trolley edge. Firmly tighten the screws (A2), the ones on the guide end first and then the central two. Check the correct assembly by making the trolley slide completely (A). If the trolley doesn't slide properly, slightly slacken the screws (A2) and repeat the above-described operations.

**! GUIDE ADJUSTMENTS MUST BE MADE ON THE EXTERNAL GUIDE ONLY.**

### 5.4 Replacing the grinding wheel



TO CARRY OUT THIS OPERATION, MAKE SURE THE MACHINE IS NOT CONNECTED TO THE MAINS.



TO CARRY OUT THIS OPERATION, WEAR THE PROTECTIVE GLOVES AND ACCIDENT-PREVENTION SHOES.

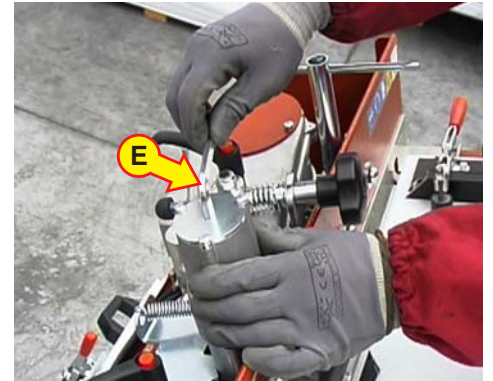
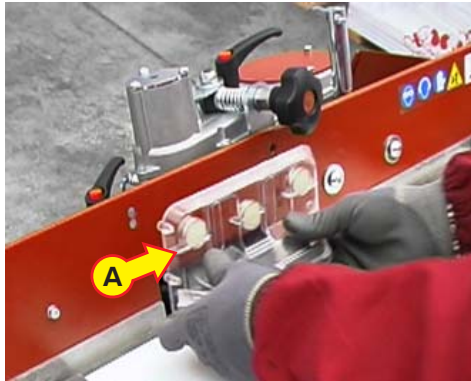

Remove the plastic spray guard (A). Open the tank door (B). Insert the B8 hexagon wrench stem (E) in the relevant seat, manually turning the grinding wheel to help the clutch.

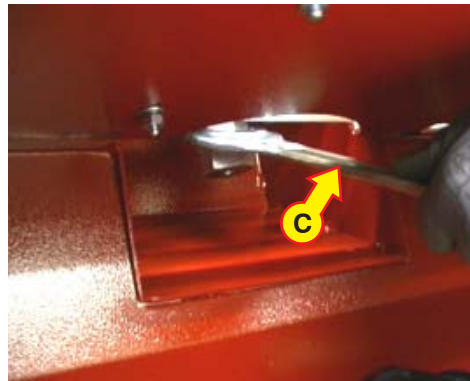

Using a size 30 wrench (C), undo the grinding wheel fixing nut (D) by turning it clockwise. Fit the new grinding wheel and lock it in place by turning the nut (D) counter-clockwise. Remove the B8 hexagon wrench (E). Try turning the cutter by hand to make sure it has been correctly fitted. Refit the spray guard (A).

## 5.4.1 Sharpening the grinding wheel

**TO CARRY OUT THIS OPERATION, WEAR THE PROTECTIVE GLOVES AND ACCIDENT-PREVENTION SHOES.**



Position the spray guard so that the brushes are in contact with the carriage table. Turn the machine on and wait for cooling water to reach the grinding wheel. Insert the sharpening stone in the stone holder. Hold the sharpening stone (**A**) against the grinding wheel. Hold it down whilst turning it alternately rightwards and leftwards. This operation must be repeated until the grinding wheel is sharp again.

**NEVER USE THE SHARPENING STONE WITHOUT THE RELATIVE HOLDER.**

## 5.5 Starter replacement

**TO CARRY OUT THIS OPERATION, WEAR THE PROTECTIVE GLOVES AND ACCIDENT-PREVENTION SHOES.**

**FOR THIS OPERATION, MAKE SURE THE MACHINE IS NOT CONNECTED TO THE MAINS AND THE TANK IS EMPTY.**

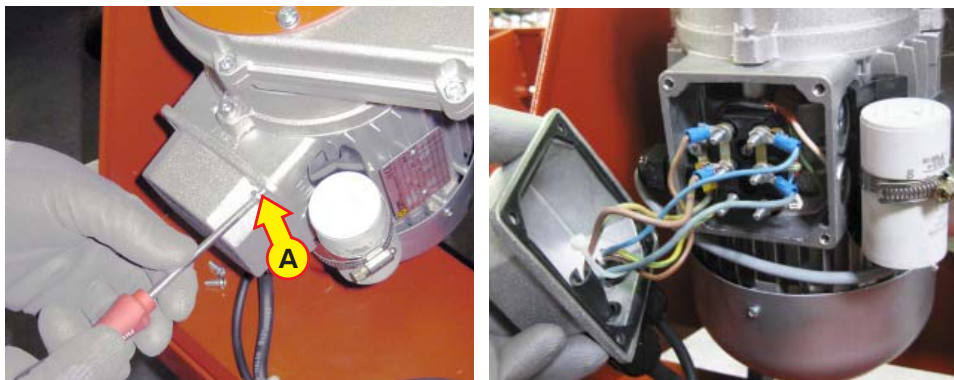

To remove the starter, unscrew the 2 fixing screws. Unscrew the screws of the motor terminal board cover (**A**) and disconnect the connecting cables. Assemble the new starter, restoring the connections in the motor terminal board and paying attention not to crush the wires.





**MAKE SURE THE STARTER VOLTAGE CORRESPONDS TO THE MACHINE SUPPLY VOLTAGE.**

## 5.6 Recycle pump replacement



**TO CARRY OUT THIS OPERATION, WEAR THE PROTECTIVE GLOVES AND ACCIDENT-PREVENTION SHOES.**



**FOR THIS OPERATION, MAKE SURE THE MACHINE IS NOT CONNECTED TO THE MAINS AND THE TANK IS EMPTY.**

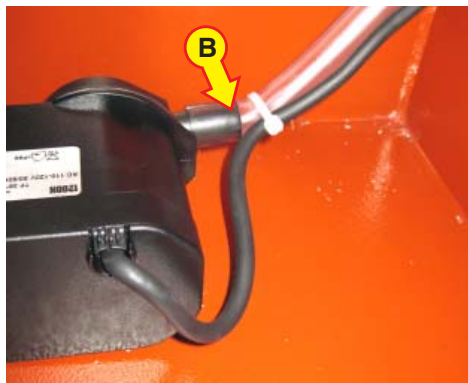
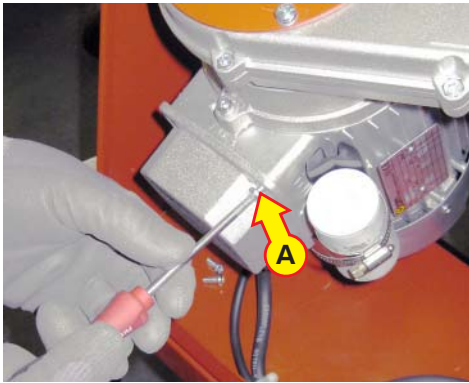

Empty the tank. Open the terminal block cover of the main electric motor (A). Unplug the pump's power supply cable. Disconnect the water delivery hoses (B). Replace the damaged pump with a new one, and restore connections. Close the terminal board cover, paying attention not to crush the wires. Reconnect the delivery hoses.



**AFTER THE REPLACEMENT, MAKE SURE THE CONNECTIONS IN THE TERMINAL BOARD HAVE BEEN MADE CORRECTLY.**

## 5.7 Starter or thermal relay replacement

 **TO CARRY OUT THIS OPERATION, WEAR THE PROTECTIVE GLOVES AND ACCIDENT-PREVENTION SHOES.**

 **FOR THIS OPERATION, MAKE SURE THE MACHINE IS NOT CONNECTED TO THE MAINS AND THE TANK IS EMPTY.**



Remove the starting device unscrewing the fixing screws (A). Disconnect the electric cables and replace the on/off switch or the damaged thermal relay (B). Reconnect the cables and tighten with the previously removed screws. Make sure the seal gasket (C) is not damaged. Replace it if needed.

## 6.1 OPTIONAL ACCESSORIES

### 6.2 Set-squares

Set-square for 80 x 60 cm (31 1/2" x 23 20/32") or 120 x 60 cm (47 1/4" x 23 20/32") sizes

To profile large-sized materials or to improve the firmness of the material on the trolley, set-squares for 80 x 60 cm (31 1/2" x 23 20/32") or 120 x 60 cm (47 1/4" x 23 20/32") are provided according to the trolley used.

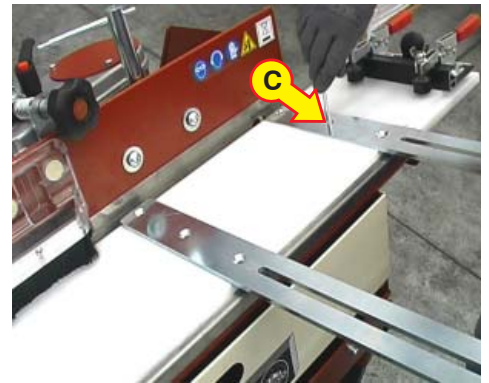
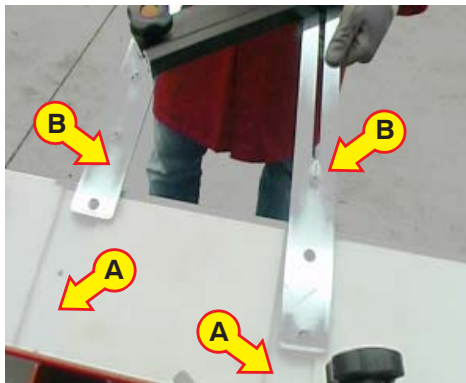

Insert the nuts in their seats on the trolley.  
Place the supports (B) in the groove and tighten the screws (C).

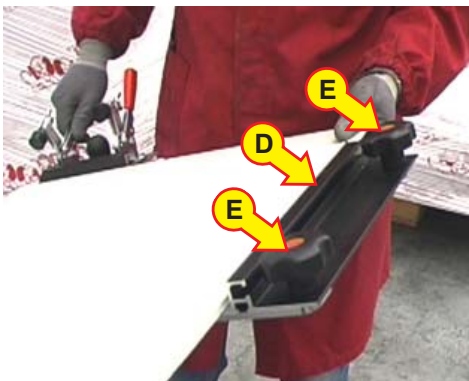

Assemble the square (B) on the supports (D) by means of the knobs (E). Make sure the square (D) slides smoothly on the supports (B).

### 6.3 Tubular junction

This tool is used to combine 2 machines, as previously illustrated in chapter 4.9.



## 7.1 Trouble-shooting

<b>Problem</b>	<b>Cause</b>	<b>Solutions</b>
<b>The machine does not work</b>	The plug is not correctly inserted in the power socket.	Push the plug completely into the power socket.
	Power socket undervoltage (Amp.).	Check the socket amperage.
	The power supply cable is interrupted.	Check the connection in the terminal board. Replace the power supply cable.
	Lack of voltage in the power socket.	Check or provide for the check of the power socket.
	The switch is damaged.	Replace the switch.
	The motor is interrupted.	Contact the retailer or the authorized technical service centre.
<b>The grinding wheel does not turn</b>	The belt is broken or water has got into the drive.	Contact the authorized technical service centre or the retailer.
	Grinding wheel incorrect assembly.	Check correct grinding wheel blocking.
<b>The motor is difficult to start</b>	Condenser failure.	Contact the authorized technical service centre or the retailer.
	No voltage to the motor.	Check the supply voltage. The power supply cable is longer than 10 mt (33'). The conductors section is undersized.
	Frictions in the drive.	Contact the authorized technical service centre or the retailer.
<b>Drive noise</b>	The bearings are damaged.	Contact the authorized technical service centre or the retailer.
<b>The machine turns off during work</b>	Motor excessive temperature.	Wait for the motor to cool down.
	Thermal-amperometric protection triggered.	Search for the cause of overheating.
<b>No water to the grinding wheel</b>	The pump is not working.	Make sure the pump is free from cutting residues In case pump replacement is required, please refer to the paragraph " <b>Water pump replacement</b> ".
	The water level in the tank is too low.	Add water in the tank.
	The tap is clogged.	Clean or replace the tap.
	The water recycle hose is bended or clogged.	Disconnect the water delivery hose from the pump and blow inside it. Clean it or replace it according to the wear status.
	Holes clogged in the pump filter.	Free all the holes in the filter of the rotor cover.
<b>Excessive backlash in the trolley sliding</b>	The guides are not aligned properly.	See paragraph " <b>Trolley adjustment</b> ".
<b>The grinding wheel does not cut "Grinding wheel sharpening"</b>	Worn grinding wheel.	Dress the diamond rim, see paragraph.
	Unfit grinding wheel.	Assemble suitable grinding wheel, see paragraph " <b>Recommended grinding wheel</b> ".

## Spare parts and electric diagram

## 8.1 Spare parts

<b>ITEM</b>	<b>ART. CODE</b>	<b>DESCRIPTION</b>
1	039CA03A2	TROLLEY FOR <120X12 CM (47 1/4" x 4 22/32") SIZES
1/1	256LA06D2	TROLLEY PLANE
1/2	305PF01C	OVAL KNOB
1/3	306IP03C	IHANDLE
1/4	427BLOCOM	TILE STOPPING DEVICE
1/5	427LA12D1	ANTISKID STOP
1/6	202SP02D	DESTAKO SHIM
2	039CA04A2	TROLLEY FOR SIZES EXCEEDING >120X80 CM (47 1/4" x 4 22/32")
2/1	191AE06D	SQUARE
2/2	256LA07D2	TROLLEY PLANE
2/3	305PF01C	OVAL KNOB
2/4	427BLOCOM	TILE STOPPING DEVICE
2/5	202SP02D	DESTAKO SHIM
3	114TO04D4	INOX "C" SLIDING GUIDE
4	114TO05D4	INOX SLIDING GUIDE/SLIDE
5	114TO05D4DX	INOX RIGHT SLIDE
6	114TO05D4SX	INOX LEFT SLIDE
7	129DE03D	LEFT HEXAGONAL NUT
8	202FC01D	DRAWERLOCK
9	202FG02D	LEGS STOP
10	202PP03D	PUMP HOLDER
11	235BU04A	230V 50HZ TR.12A STARTER
11	235BU05A	110V 50/60HZ TR.20A STARTER
11	235BU06A	230V 60HZ TR.15A STARTER
11/1	234MD01C	16A 230V 50/60HZ MICRO CIRCUIT-BREAKER NO THERMAL RELAY
11/1	234MT01A	230V C MICRO CIRCUIT-BREAKER WITH 15A THERMAL RELAY
11/1	234MT04A	115V C MICRO CIRCUIT-BREAKER WITH 20A THERMAL RELAY
11/2	234TR06C	12A THERMAL RELAY
11/3	246PM03D	MICRO CIRCUIT-BREAKER HOLDER + BASE
11/4	312N301C	3X1.5 NEOPRENE CABLE
11/5	312SK01D	NEOPRENE CABLE WITH "EU" PLUG
11/5	312US01D	NEOPRENE CABLE WITH "USA" PLUG
11/6	320GH04C	BS11 CABLE GLAND RING NUT
11/7	320PR01C	PG11 CABLE GLAND WITH RING NUT
11/8	320PS01C	BS11 CABLE GLAND RING NUT
12	240	230V 50HZ SUBMERSIBLE PUMP
12	240422	230V 60HZ SUBMERSIBLE PUMP
12	240110	110V 50/60HZ SUBMERSIBLE PUMP
13	263LX01A1	CUTTER PROTECTION
14	288L	DIAMOND DRESSING STONE
15	305MR16C	RETRACTABLE HANDLE

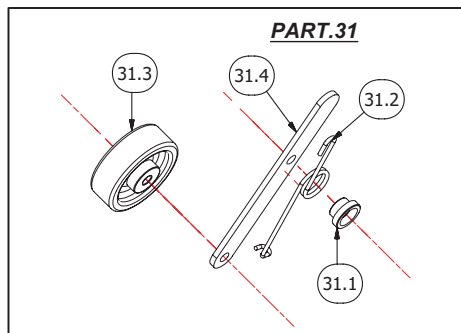
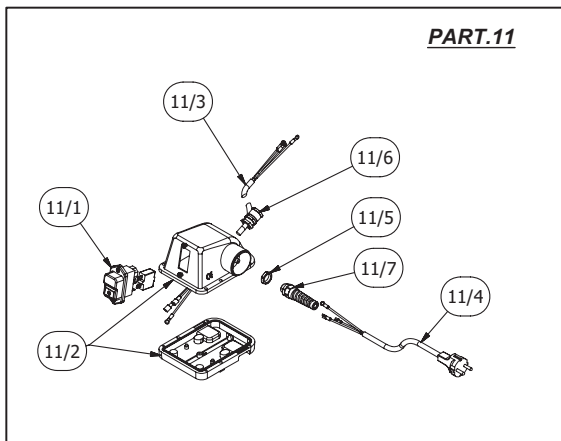
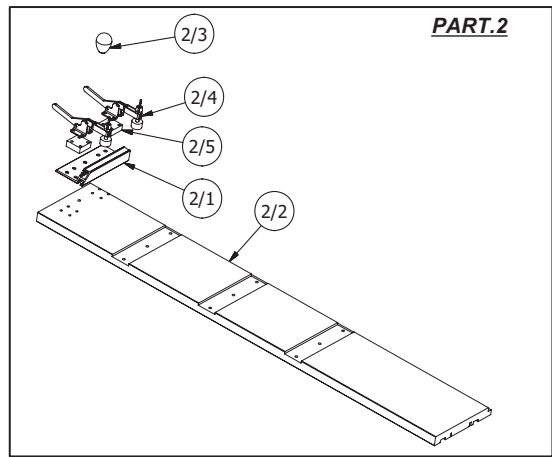
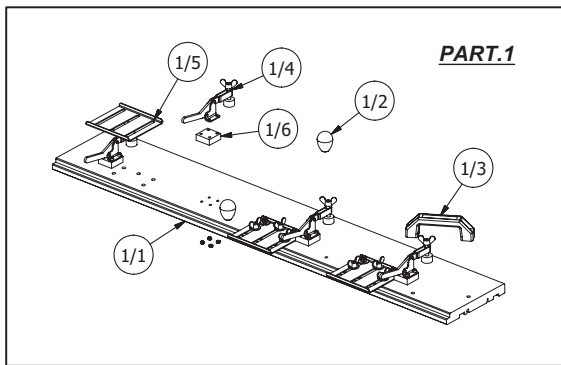
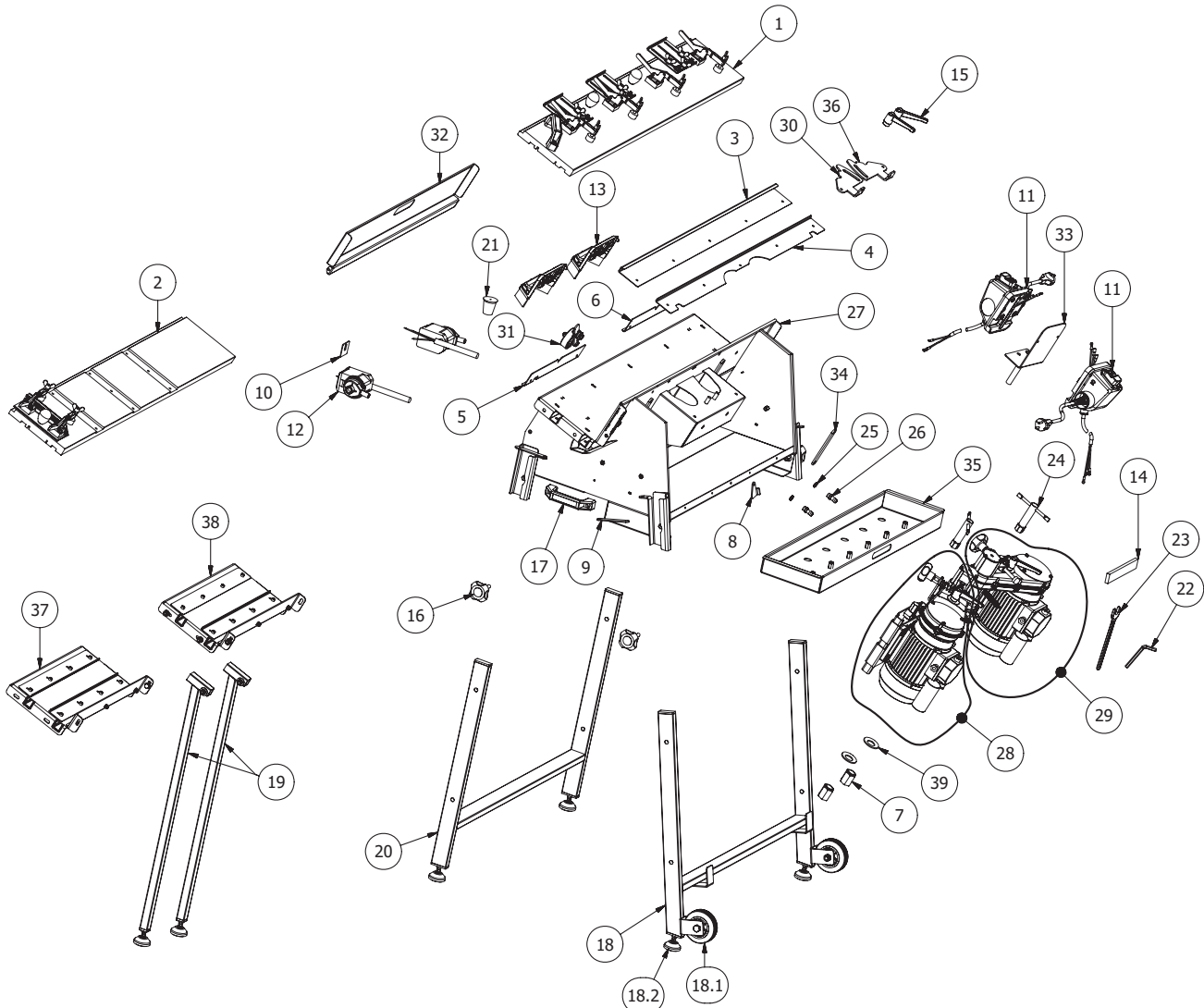

<b>ITEM</b>	<b>ART. CODE</b>	<b>DESCRIPTION</b>
16	305PM35C	KNOB
17	306IP03C	HANDLE
18	311SI06A	"H" LEG WITH WHEELS
18.1	315CB05C	RUBBER WHEEL
18.2	379PIE03C	ADJUSTABLE FOOT
19	311SI07A	LEG EXTENSION SUPPORT
20	311SI06A1	"H" LEG WITHOUT WHEELS
21	322CN03C	CONICAL PLUG
22	323BR05C	ALLEN WRENCH 8
23	323CH20C	CH 30 WRENCH
24	323TU19C	SOCKET WRENCH19
25	324DA01C	1/4" GAS NUT
26	324PG02C	RUBBER COUPLER Ø12 1/4" GAS
27	325VT01D2	FRAME TANK
28	427GR	BULL ADV/BI-BULL MOTOR GROUP
29	428GR	BI-BULL MOTOR GROUP
29	297IN86D	MOT.1,1KW 1,5HP 230V 50/60HZ
29	297IN86D60H	MOT.1,1KW 1,5HP 230V 60HZ
29	297IN86D/110	MOT.1,1KW 1,5HP 110V 50/60HZ
29	2871601C	16MF (230 V 50/60HZ) CAPACITOR
29	2878001C	80MF (110 V 50/60HZ) CAPACITOR
29	114TO01D	SLIDING LIFT GUIDE
30	427LA15D	MANDREL STOP
31	427PRE01A	PRESSING DEVICE
31.1	310BS02D	HEAD
31.2	314TO03D	TORSION SPRING
31.3	315CB07C	WHEEL C/BOC
31.4	377PR03D	WHEEL HOLDER
32	428LA05D	DOOR
33	428LA06D	STARTERS SUPPORT
34	428LA07D	MOTOR GROUP FIXING BRACKET
35	428LA13D	DRAWER
36	428LA15D	MANDREL STOP
37	428PR01A	RIGHT EXTENSION
38	428PR02A	LEFT EXTENSION
39	900ROND50T	GRINDING WHEEL STOP BELLEVILLE WASHER



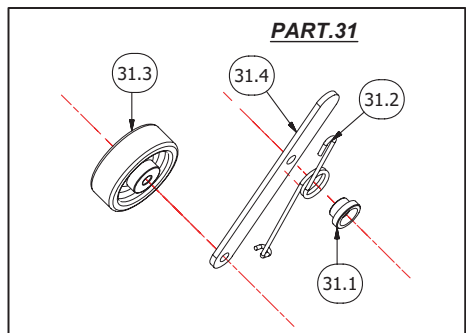
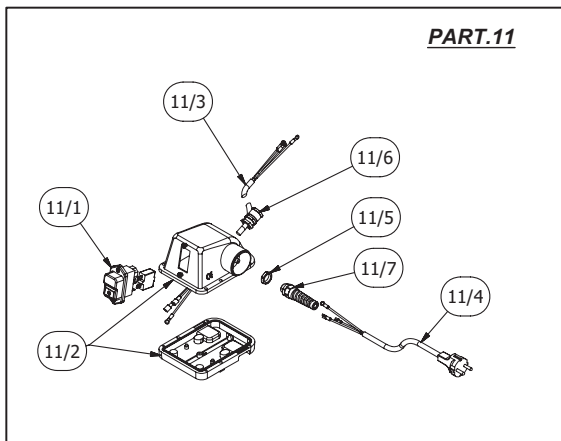
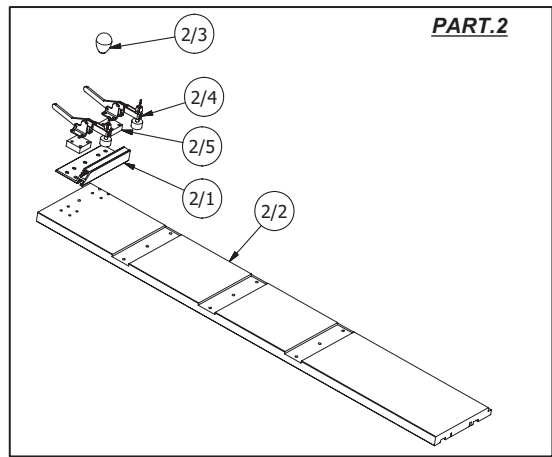
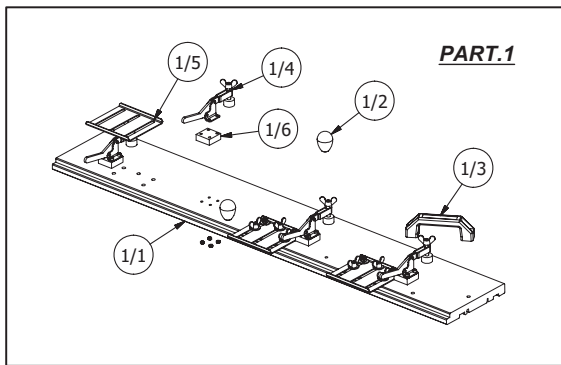
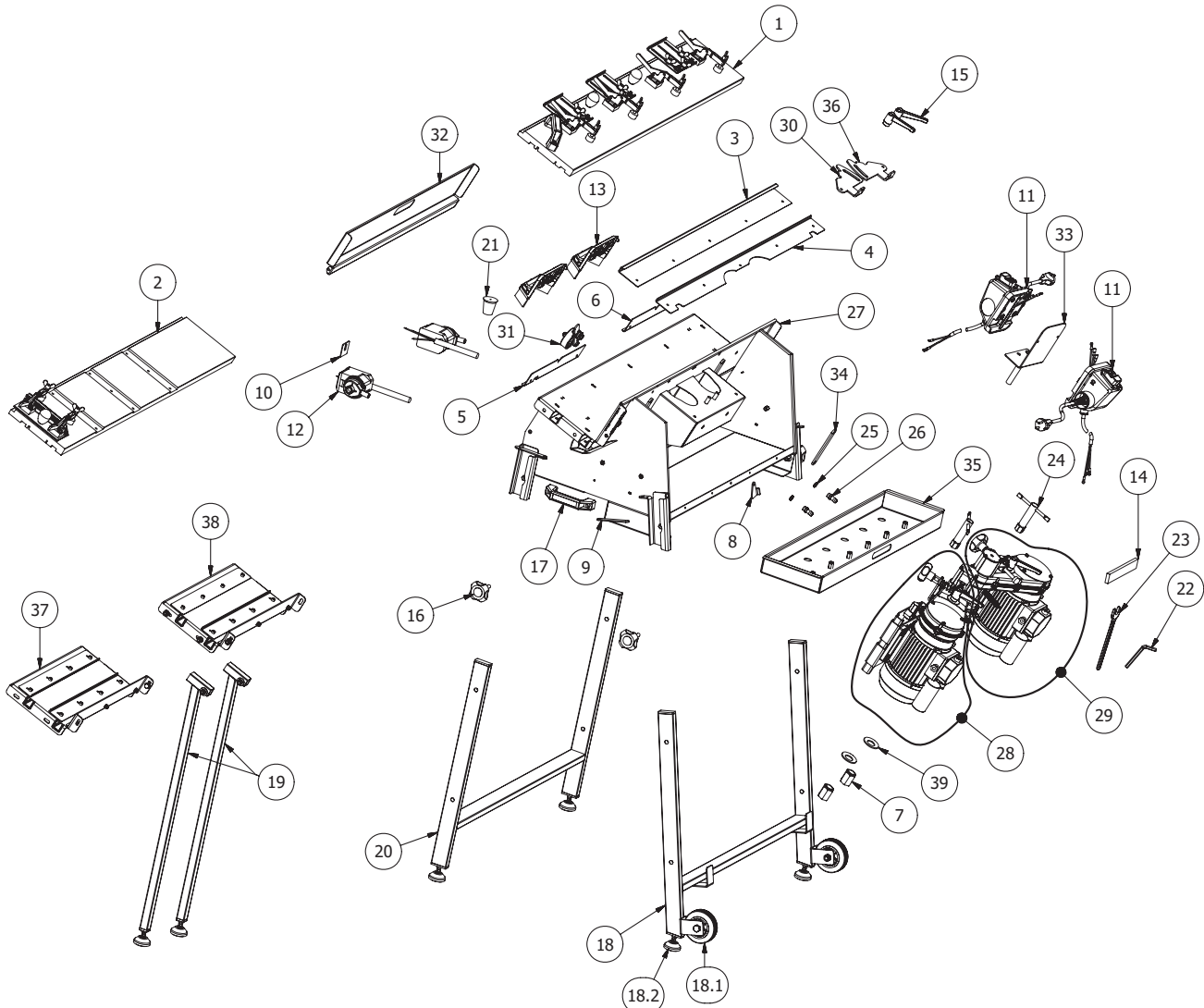

## 8.2 Electric diagram

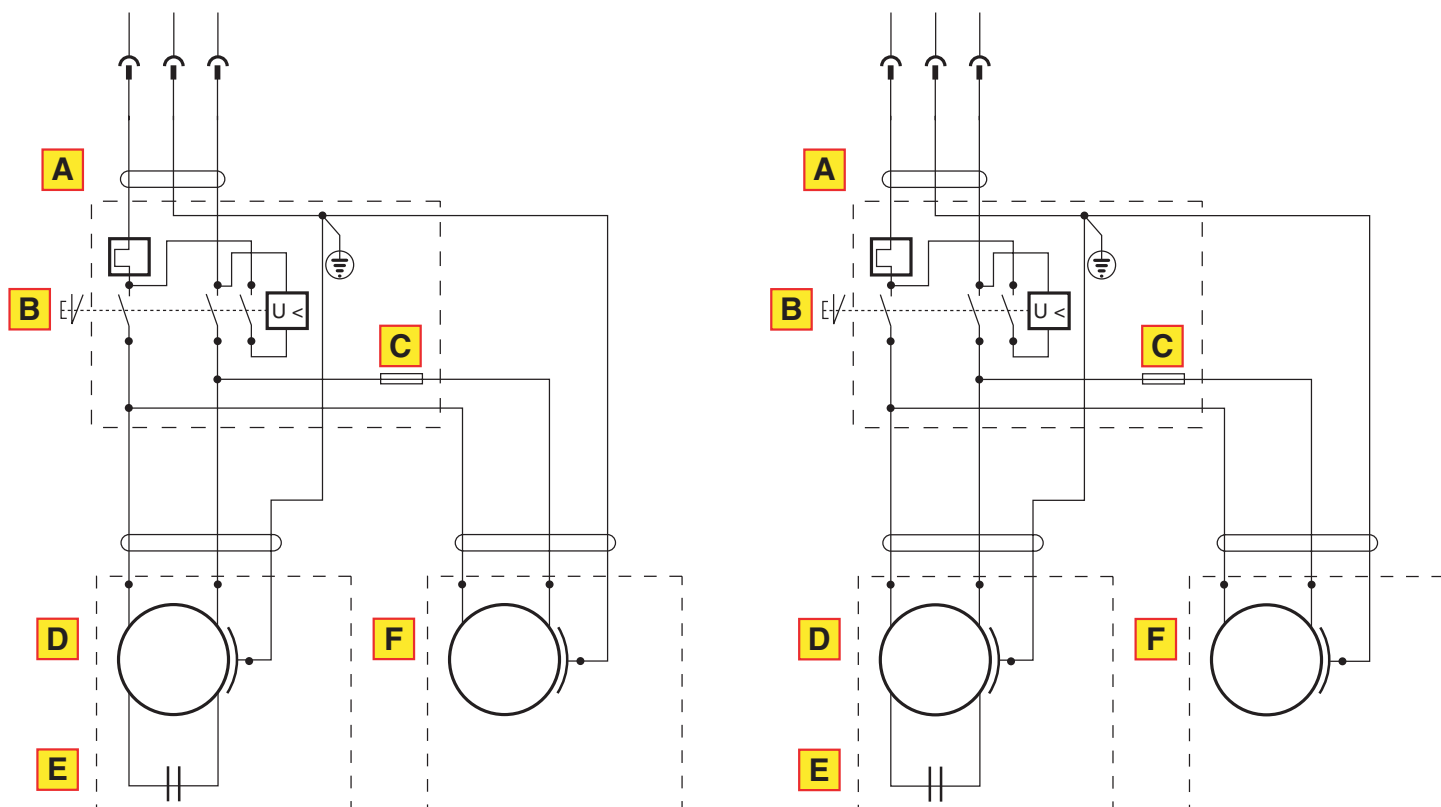

	230V - 50 / 60 Hz	110V - 50 / 60 Hz
<b>A</b>	3G 1,5H 07 RNF	3G 2,5H 07 RNF
<b>B</b>	9 / 11 A	17 / 21 A
<b>C</b>	F 1 A (x2)	F 2 A (x2)
<b>D</b>	SINGLE-PHASE 230V - 50 / 60Hz 1,1 kW (x2) 9,5A 2800 - 3360 rpm CLASS F MOTOR	SINGLE-PHASE 110V - 50 / 60Hz 1,1 kW (x2) 17,8A 2800 - 3360 rpm CLASS F MOTOR
<b>E</b>	230V - 20 $\mu$ F	110V - 100 $\mu$ F
<b>F</b>	230 V - 50 / 60Hz 13 W 0,84 A 2800 n <sup>-1</sup>	110 V - 50 / 60Hz 13 W 1,6 A 2800 n <sup>-1</sup>

TO BE  
FRANKED



**RAIMONDI**  
S.p.A.  
MACHINES & TOOLS FOR THE TILE & STONE PROFESSIONAL

Via dei Tipografi, 11  
41100 MODENA (Italy)



**30**  
YEARS  
1974 - 2004



**RAIMONDI**  
S.p.A.

MACHINES & TOOLS FOR THE TILE & STONE PROFESSIONAL

**WARRANTY  
CERTIFICATE**



<b>B</b>	<b>WARRANTY</b>		Model Bibulldog ADV	Registration number <input style="width: 90%;" type="text"/>
	Purchaser <input style="width: 95%;" type="text"/>			
Address <input style="width: 95%;" type="text"/>				
Postal code	<input style="width: 20px;" type="text"/>	<input style="width: 20px;" type="text"/>	Town	Province
Phone	<input style="width: 100%;" type="text"/>		Fax	<input style="width: 100%;" type="text"/>
Activity	<input type="checkbox"/> Floor layer	<input type="checkbox"/> Bricklayer	<input type="checkbox"/> Building enterprise	
	<input type="checkbox"/> Other			
Date of purchase	Name, address and stamp of the retailer			
<input style="width: 20px;" type="text"/>	<input style="width: 20px;" type="text"/>	<input style="width: 20px;" type="text"/>	<input style="width: 20px;" type="text"/>	<input style="width: 20px;" type="text"/>
<p>Data have been entered in our lists with a view to sending information and promotional material. At any time, in line with art.13 of the law 675/96, you will be able to access your data, request modification or erasure thereof, or oppose their use by writing to: RAIMONDI S.p.A. Via dei Tipografi n. 11 - 41100 MODENA (Italy)</p>				
<b>TO BE SENT ENTIRE LY FILLED IN, WITHIN 10 DAYS FROM THE DATE OF PURCHASE.</b>				



<b>A</b>	<b>WARRANTY</b>		Model Bibulldog ADV	Registration number <input style="width: 90%;" type="text"/>
	TO BE SHOWN TO THE TECHNICIAN			
Purchaser <input style="width: 95%;" type="text"/>				
Address <input style="width: 95%;" type="text"/>				
Postal code	<input style="width: 20px;" type="text"/>	<input style="width: 20px;" type="text"/>	Town	Province
Date of purchase	<input style="width: 20px;" type="text"/>	<input style="width: 20px;" type="text"/>	<input style="width: 20px;" type="text"/>	<input style="width: 20px;" type="text"/>
<p>Warranty clauses:</p> <ol style="list-style-type: none"> <li>1. The machine warranty covers a 12-month period since the date of purchase.</li> <li>2. The purchase date is the one indicated on the receipt for item purchased or invoice issued upon delivery of the machine by the retailer.</li> <li>3. Any warranty becomes null and void if the B part is not entirely filled in and if sent later than 10 days after the date of purchase (postmark date).</li> <li>4. By warranty we mean replacement or repair free of charge of components found to be defective since manufacturing.</li> <li>5. Replacement of components, if made by the retailer, will be recognized free of charge once replaced components have been returned to our headquarters to be examined and declared as defective. Labor expenses are not included in the warranty.</li> <li>6. All transport expenses will be charged on the purchaser.</li> <li>7. The warranty does not cover parts subjected to wear, damage caused by negligence, improper use and installation and, in any case, issues not resulting from ordinary operation of the machine.</li> <li>8. The warranty becomes null and void if the machine is tampered with or repaired by unauthorized personnel.</li> <li>9. The warranty does not cover replacement of the machine and extension of the warranty following intervention for failure issues.</li> <li>10. Nobody is entitled to modify the warranty conditions, nor to issue other warranties, in written or oral form, without the written authorization of RAIMONDI S.p.A.</li> <li>11. The warranty does not cover compensation for damage, either direct or indirect, of any nature, to persons or objects, resulting from use or suspension of use of the machine.</li> </ol>				

Date of production  /  /

Registration number