

OWNERS MANUAL

High Speed Hand Held Electric



Models:
CE414-350



FORM: CE414-350 rev 5-2016

WARRANTY

Norton warrants all products manufactured by it against defects in workmanship or materials for a period of one (1) year from the date of shipment to the customer.

The responsibility of Saint-Gobain Abrasives under this warranty is limited to replacement or repair of defective parts at Saint-Gobain's, Plainfield Indiana facility, or at a point designated by it, of such part as shall appear to us upon inspection at such point, to have been defective in material or workmanship, with expense for transportation borne by the customer.

In no event shall Saint-Gobain Abrasives be liable for consequential or incidental damages arising out of the failure of any product to operate properly.

This warranty is in lieu of all other warranties, expressed or implied, and all such other warranties are hereby disclaimed.

Important: Before placing equipment in operation, record the following information:

MODEL: _____ **SERIAL NO.** _____

PURCHASE FROM: _____

ADDRESS: _____

CITY _____ **STATE** _____ **ZIP** _____

TELEPHONE NO. _____

Before using this equipment, make sure that any person using it reads and understands the instructions in this owner's manual.

Instruction Manual Electric Hand Held High Speed Saw CE414-350

Dear customer

Thank you for purchasing this quality product from Saint-Gobain Abrasives.

For many decades, we have been a producer of professional duty construction equipment. Each of our products has been rigorously tested to withstand use of the everyday professional operator and to meet all safety regulations.

With the main body composed primarily of high quality aluminium and reinforced plastic components our products promise long service life with minimal down time.

We know you will be satisfied with your purchase because we have put a lot of care and attention to the assembly and testing of your product.



Before operating this machine, read and fully understand these operating instructions and always observe all safety regulations and instructions. If you have any further questions after reading these operating instructions, contact Saint-Gobain Abrasives customer service at 800-554-8003.



Observe the maintenance guidelines closely to ensure the long service life and safe operation of your equipment

Table of Contents

1	Information about these operating instructions	5
1.1	<i>Notational conventions used in the operating instructions</i>	5
2	Warning, Instruction and Notice Icons.....	5
3	Safety Provisions	8
3.1	<i>Correct Use</i>	8
3.2	<i>General Safety Notes</i>	8
	<i>Dust and Silica Warning</i>	7
3.3	<i>Prescribed Work Clothing / PPE (Personal Protection Equipment).....</i>	8
3.4	<i>In Transport</i>	9
3.5	<i>Before Use.....</i>	9
3.6	<i>Electrical Safety.....</i>	9
3.7	<i>During Work.....</i>	9
4	Power Tool Description and Features	13
4.1	<i>Technical Data.....</i>	13
4.2	<i>Scope of Delivery</i>	14
4.3	<i>Important Operating and Function Features.....</i>	14
4.4	<i>Power trigger usage</i>	15
4.5	<i>Electrical safety system.....</i>	16
5	Preparing for Use	17
5.1	<i>Installing/Removing the Blade</i>	17
5.2	<i>Adjusting the Blade Guard.....</i>	18
5.3	<i>Water Connection for Wet Cutting.....</i>	18
6	Power Tool Use	19
6.1	<i>Cutting Blades</i>	18
6.2	<i>Permissible Cutting Area and Danger From Kickback or Drawing Along.....</i>	20
6.3	<i>Working Behaviour and Working Technique</i>	21
6.4	<i>Cutting Metal</i>	21
6.5	<i>Cutting Concrete/Masonry Materials</i>	21
7	Operating and Maintenance Notes	22
7.1	<i>Cleaning and Care.....</i>	22
7.2	<i>Replacing the Carbon Brushes.....</i>	23
7.3	<i>Using the Kick Stand</i>	24
8	Warranty.....	25
9	Service Parts.....	25

1 Information About These Operating Instructions

These operating instructions are an integral part of the motor device.



They contain important information and instructions for handling the motor device. Always follow any specified safety regulations and instructions, as they are a prerequisite for ensuring that you are working safely with the equipment.



These operating instructions must be kept available at the place of use of the equipment at all times, and they must be read carefully by everybody who works on or with the equipment (including for maintenance, care and repairs).

These operating instructions must only be used as operating instructions for the motor device CE414-350. Any utilisation of the contents (text and graphics illustrations) – even in excerpts – without our prior written consent shall be forbidden and may be prosecuted.

1.1 Notational Conventions Used in the Operating Instructions

Text highlights

Xxxxx Underlined text marks interim headlines.

Xxxxx Text in italics marks advice and notes that facilitate use of the motor device for the user.

1 Xxxxx Numbered text with a black background marks main chapter headlines.

1.1 Xxxx Numbered text with a grey background marks main subchapter headlines.

Xxxxxxx Frames mark especially highlighted sections.

Structure

The operating instructions are structured by numbered main and subchapters. The table of contents on page 4 shows an overview of the structure.

Header

To make it easier for the user to find the chapters, the header names the main chapter to which the content on the respective page belongs.

Pictures and diagrams

Some graphical illustrations in these operating instructions are schematic illustrations or principle illustrations and may not show exactly your device model. The conveyed contents, however, are binding in any case.

2 Warning, instruction and Notice Icons

Important: If one or several icons in these operating instructions are centred and directly below a chapter header the notice applies for the entire chapter.

Warning, Instruction and Notice Icons used in the Operating Instructions and on the Equipment:



Danger! Failure to comply with the instructions could cause accidents with potentially life-threatening injuries



Caution! Failure to comply with the instructions could result in damage to the equipment or other material damage



Carefully read the operating instructions. This applies before taking the equipment into operation and before any cleaning, maintenance or assembly work.



Always wear the prescribed clothing. → Chap. 3.3, page 9



Always wear sturdy shoes with good grip.



Wear safety gloves. This applies to all work with or on the equipment



Before use, put on helmet, ear defenders and a visor.



Switch off the motor!



Noise level L_{WA} = 100 dB(A).



Never continue work with damaged cutting discs.



Only use cutting discs approved for a speed of $\geq 3.900 \text{ rpm (min}^{-1}\text{)}$



Attention: Kickback!
Notes in chap. 6.2 as of page 20 must be observed under all circumstances!



Attention: Danger of fire from sparks.



Wear breathing protection.



Do not use circular saw blades.

WARNING

Dust and Silica Warning

Grinding/cutting/drilling of masonry, concrete, metal and other materials can generate dust, mists and fumes containing chemicals known to cause serious or fatal injury or illness, such as respiratory disease, cancer, birth defects or other reproductive harm. If you are unfamiliar with the risks associated with the particular process and/or material being cut or the composition of the tool being used, review the material safety data sheet and/or consult your employer, the material manufacturer/supplier, governmental agencies such as OSHA and NIOSH and other sources on hazardous materials and make certain to comply with all product warnings and instructions for the safe and effective use of the material being cut. California and some other authorities, for instance, have published lists of substances known to cause cancer, reproductive toxicity, or other harmful effects.

Control dust, mist and fumes at the source where possible. In this regard use good work practices and follow the recommendations of the manufacturer/supplier, OSHA/NIOSH, and occupational and trade associations. Water should be used for dust suppression when wet cutting is feasible. When the hazards from inhalation of dust, mists and fumes cannot be eliminated through engineering controls such as either vacuum and/or water mist, the operator and any bystanders should always wear a respirator approved by NIOSH/MSHA for the material being cut.

California Proposition 65 Message

Some dust created by power sanding, sawing, grinding, drilling, and other construction activities contain chemicals known (to the State of California) to cause cancer, birth defects or other reproductive harm. Some examples of these chemicals are:

- Lead, from lead-based paints
- Crystalline silica, from bricks and cement and other masonry products
- Arsenic and chromium, from chemically treated lumber

For Addition Information Consult The Following Sources:

<http://www.osha.gov/dsg/topics/silicacrystalline/index.html>

<http://www.cdc.gov/niosh/consilic.html>

<http://oehha.ca.gov/prop65/law/P65law72003.html>

<http://www.dir.ca.gov/Title8/sub4.html>

Use Approved:



Eye Protection



Hearing Protection



Respiratory Protection



Head Protection

3 Safety Provisions

3.1 Correct use



This power tool must only be used to cut/shorten metals (hot cut) and mineral materials, such as concrete, masonry products (brick, block, pavers), with the cutting blade approved for the material and only for the working situation indicated in chap. 6 on page 19.

For specifically trained users in rescue missions, other approved cutting discs are also offered that can be used to cut various composites. These special applications are only permitted to specifically trained users.

This power tool can be used for indoor or outdoor work.

Use of this power tool for any other purpose, such as sawing of wood and to remove/grind off a material with the side surfaces of the blade is forbidden. Use of cutting tools, such as wood saw blades (which have a positive rake angle) or knives, must not be installed or used with this product disc.

3.2 General Power Tool Safety Warnings



WARNING *Read all safety warnings and all instructions. Failure to follow the warnings and instructions may result in electric shock, fire and/or serious injury.*

Save all warnings and instructions for future reference.

The term “power tool” in the warnings refers to your mains-operated (corded) power tool or battery-operated (cordless) power tool.

1. Work area safety

- a. **Keep work area clean and well lit.** *Cluttered or dark areas invite accidents.*
- b. **Do not operate power tools in explosive atmospheres, such as in the presence of flammable liquids, gases or dust.** *Power tools create sparks which may ignite the dust or fumes.*
- c. **Keep children and bystanders away while operating a power tool.** *Distractions can cause you to lose control.*

2. Electrical safety

- a. **Power tool plugs must match the outlet. Never modify the plug in any way. Do not use any adapter plugs with earthed (grounded) power tools.** *Unmodified plugs and matching outlets will reduce risk of electric shock.*
- b. **Avoid body contact with earthed or grounded surfaces, such as pipes, radiators, ranges and refrigerators.** *There is increased risk of electric shock if your body is earthed or grounded.*
- c. **Do not expose power tools to rain or wet conditions.** *Water entering a power tool will increase the risk of electric shock.*
- d. **Do not abuse the cord. Never use the cord for carrying, pulling or unplugging the power tool. Keep cord away from heat, oil, sharp edges or moving parts.** *Damaged or entangled cords increase the risk of electric shock.*
- e. **While operating a power tool outdoors, use an extension cord suitable for outdoor use.** *Use of a cord suitable for outdoor use reduces the risk of electric shock.*
- f. **If operating a power tool in a damp location is unavoidable, use a ground fault circuit interrupter (GFCI) protected supply.** *Use of an GFCI reduces the risk of electric shock.*

3. Personal safety

- a. **Stay alert, watch what you are doing and use common sense when operating a power tool. Do not use a power tool while you are tired or under the influence of drugs, alcohol or medication.** *A moment of inattention while operating power tools may result in serious personal injury.*

- b. **Use personal protective equipment. Always wear eye protection.** *Protective equipment such as dust mask, non-skid safety shoes, hard hat, or hearing protection used for appropriate conditions will reduce personal injuries.*
- c. **Prevent unintentional starting. Ensure the switch is in the off-position before connecting to power source and/or battery pack, picking up or carrying the tool.** *Carrying power tools with your finger on the switch or energising power tools that have the switch on invites accidents.*
- d. **Remove any adjusting key or wrench before turning the power tool on.** *A wrench or a key left attached to a rotating part of the power tool may result in personal injury.*
- e. **Do no overreach. Keep proper footing and balance at all times.** *This enables better control of the power tool in unexpected situations.*
- f. **Dress properly. Do not wear loose clothing or jewellery. Keep your hair, clothing and gloves away from moving parts.** *Loose clothes, jewellery or long hair can be caught in moving parts.*
- g. **If devices are provided for the connection of dust extraction and collection facilities, ensure these are connected and properly used.** *Use of dust collection can reduce dust-related hazards.*

4. Power tool use and care

- a. **Do not force the power tool. Use the correct power tool for your application.** *The correct power tool will do the job better and safer at the rate for which it was designed.*
- b. **Do not use the power tool if the switch does not turn it on and off.** *Any power tool that cannot be controlled with the switch is dangerous and must be repaired.*
- c. **Disconnect the plug from the power source and/or the battery pack from the power tool before making any adjustments, changing accessories, or storing power tools.** *Such preventative safety measures reduce the risk of starting the power tool accidentally.*
- d. **Store idle power tools out of the reach of children and do not allow persons unfamiliar with the power tool or these instructions to operate the power tool.** *Power tools are dangerous in the hands of untrained users.*
- e. **Maintain power tools. Check for misalignment or bindings of moving parts, breakage of parts and any other condition that may affect the power tool's operation. If damaged, have the power tool repaired before use.** *Many accidents are caused by poorly maintained power tools.*
- f. **Keep cutting tools sharp and clean.** *Properly maintained cutting tools with sharp cutting edges are less likely to bind and are easier to control.*
- g. **Use power tool, accessories and tool bits etc. in accordance with these instructions, taking into account the working conditions and the work to be performed.** *Use of the power tool for operations different from these intended could result in hazardous situation.*

5. Service

- a. **Have your power tool serviced by a qualified repair person using only identical replacement parts.** *This ensure the safety of the power tool is maintained.*

3.3 Prescribed Work Clothing / PPE (Personal Protection Equipment)



In order to prevent injuries, please make sure that you wear the prescribed clothing and protective equipment.



Clothes should be tight-fitting (no labels), but not hindering. When performing any work, wear a working suit of firm materials with sufficient flame resistance so that cannot catch fire by sparks flying (materials of leather, cotton after flame-inhibiting treatment or heavy close-meshed linen fabrics).

Check the information in the work clothes and ensure that no flammable materials and no easily melting materials like polyester or nylon are contained in the clothes. The working clothes must never be contaminated with flammable substances such as petrol or similar.

Never wear scarves, ties, jewellery or other clothes that may get caught in the cutting disc or blade, or objects in the environment, or the power tool. Tie back long hair and secure it under a helmet.



Wear a protective helmet during any work. Use personal hearing protection. Eye/face protection is mandatory pursuant to ANSI Z 87.1.



Wear firm safety shoes with steel toes and a good grip.



Wear protective gloves with non-slip palms.



Use breathing protection for dry cutting as protection from dust.

3.4 In Transport



- Before carrying the power tool (even for short distances), always switch off the motor, wait until the cutting disc has stopped, and disconnect the power supply. Carry the power tool by the top handle and have the cutting blade facing down and to the rear. Never carry the power tool by the power cable.
- Never carry or transport the power tool with the cutting disc or blade turning.

Advice: We recommend that you keep the original packaging in order to protect the equipment against transport damage in case you ever need to ship it or transport it.

3.5 Before Use



Before starting, check the entire power tool for operationally safe condition such as:

- The power trigger must move freely and return automatically to the idle position where the auto lock can engage fully. It must not be possible to operate saw without pushing (unlocking) the power trigger.
- The cutting blade/disc must be attached firmly to the spindle.
- In case of irregularities, recognisable damage, improper settings or limited function, the power unit must not be started. In such cases, have the power tool inspected by specialist workshops authorised by us.
- Only use the power tool if it is in completely assembled condition.
- All guards/cowl should be in place. Never use the machine if they have been removed!

3.6 Electrical Safety



- Keep at least 3 metres distance from any flammable material when operating this machine.
- Plug the power tool into the appropriate matching grounded outlet. Do not attempt to adapt the plug head to use with a non matching outlet.
- Avoid contact with earthed or grounded surfaces to avoid electric shock.

-
- Keep the power tool away from water. Do not leave the machine outside where it may be rained upon. Water exposure will increase the risk of electric shock.
 - Do not pressure wash or wash the machine. Water exposure will increase the risk of electric shock.
 - Do not carry the tool by the power cord. Do not use the machine if the cord is damaged. A damaged cord will increase the risk of electric shock. If damaged have the cord repaired by a certified technician immediately.
 - Use extension cables with the correct length and gauge. Refer to section 4.1 and view the recommended extension cable chart if not known what type of extension cable to use.
 - Keep extension cables unravelled during use to maintain the power tool's efficiency.
 - Only use undamaged extension cables to reduce the risk of electric shock.
 - When operating the power tool, make sure the power cable is always behind you.
 - Do not use the power tool if the power trigger does not turn on the motor. A malfunctioning power switch should be repaired by a certified technician.

3.7 During Work



In addition to the safety provisions already listed, the following safety provisions also apply when working with the motor device:

- Secure the workplace against accidental access by third parties, e.g. with warning signs. Only persons involved and wearing protective clothes must be present within 100' (30 m) around the working area.
- Check the site of deployment for possible dangers.
 - If spark created during cutting work must never be performed close to potentially explosive gases of liquids, or easily flammable objects.
 - No electrical lines must be placed in the area to be cut.
 - Objects that may fall off or topple over during work must be secured or removed from the working environment first.
 - Prepare the workplace so that secure backing away is possible.
- The work piece to be cut must be free of foreign bodies such as screws, nails or stones.
- When working in residential areas, observe the noise protection provisions.
- Work carefully, considerately and calmly and do not endanger any other persons.
 - Ensure good vision and light conditions.
 - Always remain within calling distance of other persons who may administer first aid in emergencies.
 - Put in working breaks in time.
 - Be attentive towards possible danger sources and take the corresponding preventive measures. Consider that use of hearing protection limits perception of sounds. Signal sounds, calls, etc. that announce danger may also be missed.
 - Observe tripping dangers and obstacles. Never work on unstable surfaces.
 - Always hold on to the power tool with both hands and always ensure a safe and firm stance.
 - Never cut standing on a ladder.
 - Guide the power tool so that no body part is located in the extended swivel range of the cutting disc.
 - Only process the work piece to be cut with the cutting disc running; never touch the floor or other objects with the cutting disc running.
 - Do not use the power tool to lever off and shovel away objects.
- Switch off the motor when the power tool starts to behave noticeably differently.
- Danger of hearing damage!

4 Power Tool Description and Features

4.1 Technical data

Model	C414-350	
Motor	Brush Motor	
Power	Amp	15
Voltage	V	115
Hertz	hz	60
Spindle Diameter	in / mm	0.787 (20mm)
Spindle Diameter with Bushing	in / mm	1 (25.4)
Blade Shaft Speed	rpm	3,900
Blade Flange Diameter	in / mm	4 (100)
Sound of Motor Without Cutting Blade	dB	100 dB
Maximum Blade Diameter	in / mm	14 (350)
Cutting Depth	in / mm	5 (125)
Dimensions	Height x Width x Length in / mm	11.1 (282) h x 11.3 (286) w x 28.7 (730) l
Weight without cutting disc	lb / kg	22.4 (10.2)

Recommended Extension Cables

12 AWG	50'
10 AWG	75'
8 AWG	100'

4.2 Scope of Delivery

- Machine CE414-350
- Tool: Universal Wrench
- Operating instructions

4.3 Important Operating and Function Features

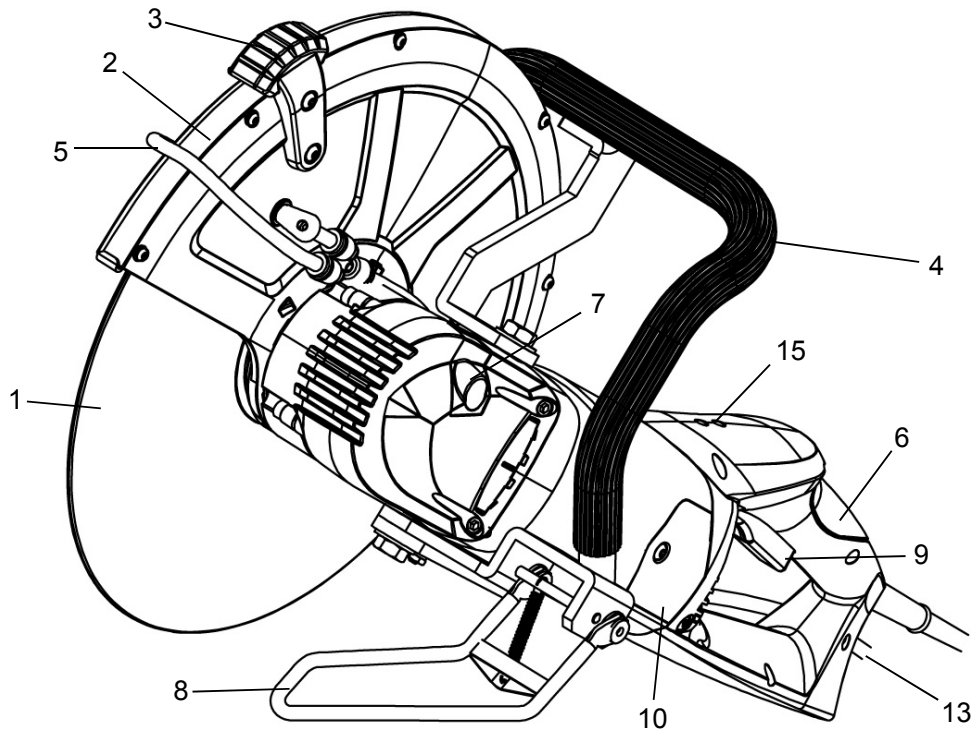

1. Cutting Blade	10. Carbon Brush Cover
2. Blade Guard	11. Blade Shaft Screw
3. Grip for Blade Guard Adjustment	12. Power Cable
4. Top Handle	13. Water Hose to Coupling
5. Water Hose	14. Water Coupling Connection (Wet Cutting)
6. Rear Handle	15. Power and Overload Indicator
7. Spindle Lock Button	16. Circuit Breaker
8. Kick Stand	17. Power Trigger Lock
9. Trigger Assemble	18. IC Board

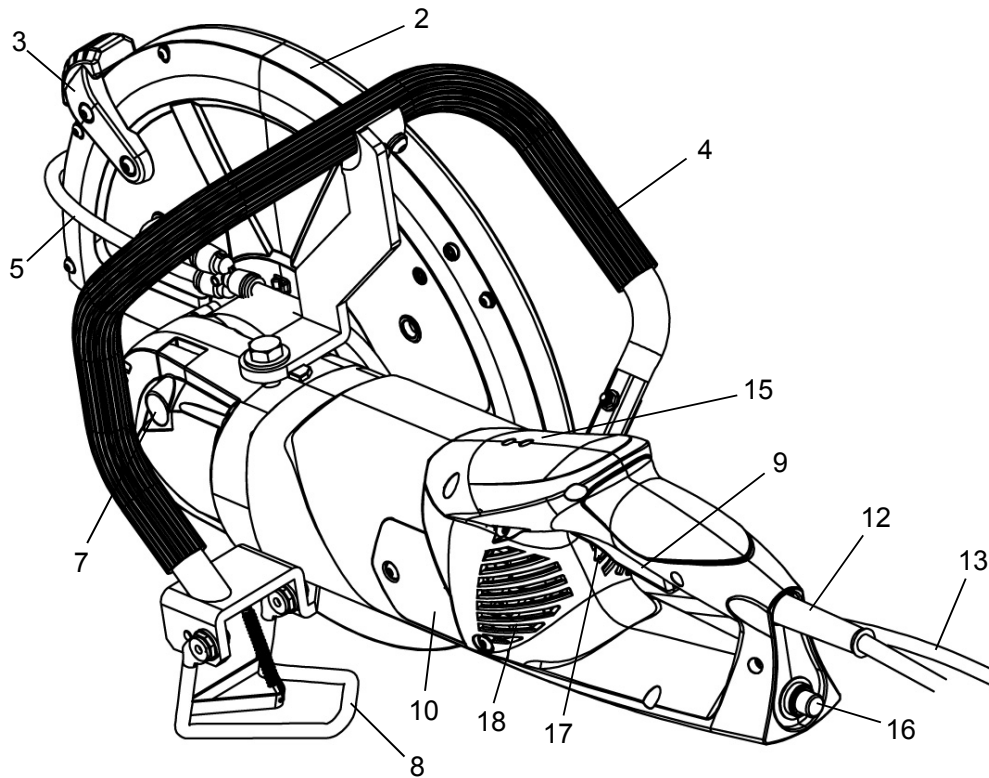

4.4 Power Trigger Usage

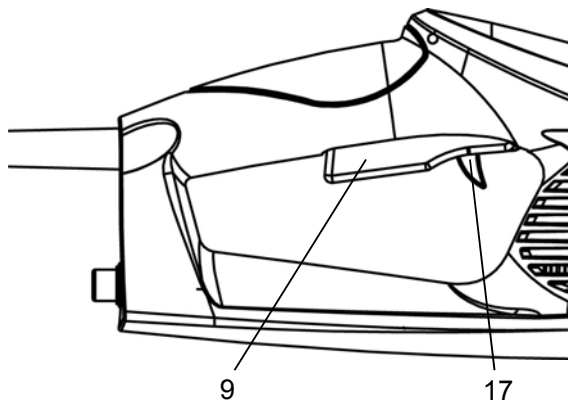

Testing functionality of power trigger

- To test the power trigger, connect the machine to the correct power supply, grasp the handle to position your fingers next to the power trigger. Using the index finger and push to disengage the lock trigger (17), shown on the left. With the lock disengaged, pull the power trigger up (9) and then release. The motor should turn on and then off when the trigger is released.
- If the motor does not turn off or blade does not stop spinning, have the switch assembly serviced immediately by a certified technician. In the mean time discontinue use of the power saw.
- The power trigger lock should also be tested. This time pull the power trigger only (9). If the motor turns on then the lock trigger is damaged and needs to be serviced. Have the switch assembly serviced by a certified technician. In the mean time discontinue use of the power saw.

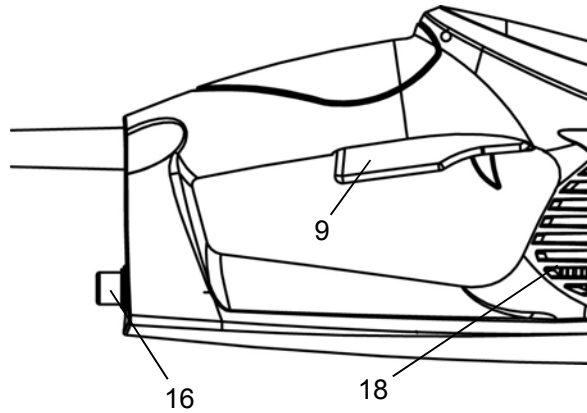

The heavy duty power switch in the power saw is coupled with two safety features. A soft start system (18) which prevents unintentional power trips during start-up, and overloads. Source of overload can be from user applying too much cutting force or from the blade jamming. The overloaded state has to be reset by releasing the power trigger (a) and then depressing it once again to return power to the motor. Before performing the reset, the source of overload should be corrected. A second safety device that runs in tandem with this system is a traditional non fuse circuit breaker (b). To reset this breaker the user must release the power trigger and depress the circuit breaker button located below the power cable. Now power can be sent to the motor once again.

5 Preparing for Use



5.1 Installing/Removing the Cutting Disc



The cutting discs used must correspond to the specifications from chap. **Error! Reference source not found.** on page **Error! Bookmark not defined.**

The power tool uses a 20mm spindle is paired with an adapter blade adapter for use with 1 inch (25.4mm) bore cuttings blade. The components are assembled as shown below, along with the universal wrench (e) included with the power tool to remove the blade bolt (d).

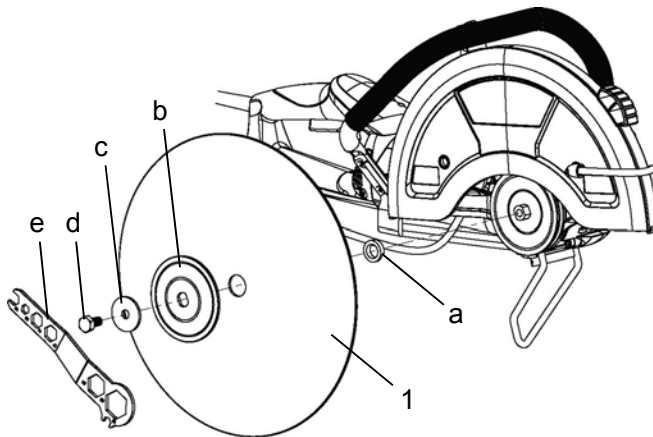

- For blade installation, the power tool must be put securely on the ground and unplugged. With the power tool handle facing you place left arm on the power tool body and use the correlating hand to press the spindle lock button (7) shown below. With the free hand use the universal wrench (e) to turn the blade bolt (d) clockwise, or away from you. Apply slight downward force from the left arm onto the motor body to keep the tool from moving, if it should:

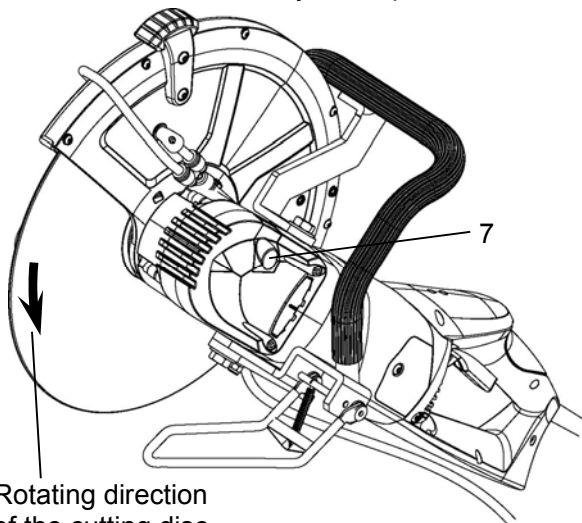

Rotating direction
of the cutting disc

- Remove the blade bolt (d), its washer (c) and outer flange (b). Install the cutting disc (1), and make sure the bore of the disc slides onto the adapter (a) all the way. Also locate the spinning direction of the disk and match it with the diagram above's note. If you are facing the blade guard, facing the side you are installing the cutting disc from. The disc must rotate clockwise.
- Once the cutting disc (1) is properly seated, reinstall the outer flange (b), washer (d) and blade bolt. Press the spindle lock button (7) again and this time use the universal wrench (e) to turn the blade bolt counter-clockwise until tight.

5.2 Adjusting the Blade Guard

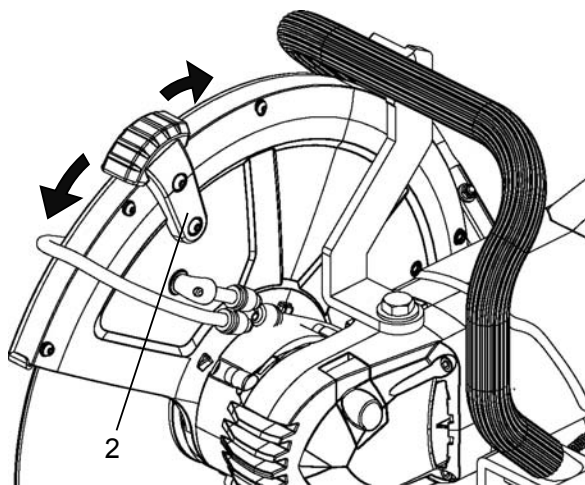

The blade guard shown on left can be swivelled forward and backward in a limited area.

For adjustment of the blade guard, the power tool must be put securely on the ground with the power supply disconnected. Securely hold the power tool at the top handle (4) with the one hand and push it firmly onto the ground. With the other hand at the handle for the blade guard adjustment (2), swivel the protective cowl accordingly.

To keep sparks and particles from being thrown at the operator, the blade guard should always be swivelled forward as far as the working situation permits.



When adjusting the blade guard ensure that the water supply line is not crimped and that blade does not contact water supply line.

5.3 Water Connection for Wet Cutting

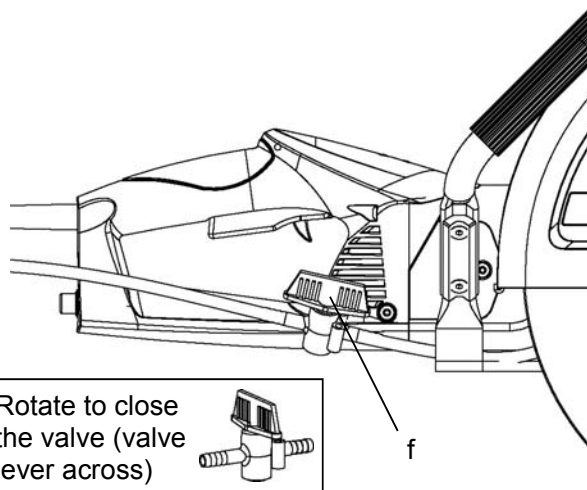

Rotate to close the valve (valve lever across)

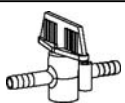

Lots of fine dust occurs when cutting mineral based materials. We recommend using the water connection when using diamond blades suitable for the material and rated for wet cutting. When cutting with the water, visibility of the material is improved, and blade life can increase due to the cooling effect of the water.

Before Wet Cutting:

- Connect suitable water line (maximum 80 PSI) or suitable pressure tank to the coupling connection (g).
- Operate the valve lever (f) to open or close the water supply to the desired flow rate.

After Wet Cutting:

- Close the water supply, i.e. put the valve lever perpendicular to the valve body.
- Let the cutting disc run at high speed for another approx. 30 seconds to completely remove the water.

6 Power Tool Use



Always observe all safety instructions and all information in this document before using this machine!

Check list for use (keywords only!)



- Before start-up:
 - Power tool in an operationally safe condition! Operating instructions complete
 - Prescribed work clothes Chap. 3.3, page 9
 - Working area inspected and secured Chap. 3.2, page 8, and Chap. 3.7, page 9
 - Blade installed Correctly Chap. 5.1, page 17, and Chap. **Error! Reference source not found.**, page 19
 - Blade Guard in best position Chap. 5.2, page 18
- During work – generally safe work: Operating instructions complete
 - Inspecting the working environment Chap. 3.7, page 9, Chap. 6.2, page 20, and Chap. 6.3, page 21
 - Water connection for wet cutting Chap. 5.3, page 15
 - Proper cutting technique Chap. 6.3, page 21, Chap. 6.4, page 21, and Chap. 6.5, page 21
- After work: Operating instructions complete
 - Cleaning and care Chap. 0, page 22
 - Replacing the carbon brushes Chap. 7.2, page 20
 - Using the flip stand Chap. 7.3, page 22
 - Maintenance Operating instructions complete

6.1 Blades



Only use Diamond Blades that correspond to the standards EN 12413 and EN 13236 and that are perfectly undamaged. The approved maximum speed of the cutting disc must be $\geq 4,450 \text{ rpm (min}^{-1}\text{)}$.

For cutting of metals (hot cutting) and cutting of mineral based materials – block, brick, concrete, stone (cold cutting), different cutting discs are offered. Use only the blades that are approved for the material to be cut.

Diamond cutting blades are only approved for cutting mineral based materials. When installing the diamond blade, always observe the rotating direction indicated on the diamond blade; otherwise, the cutting effect will reduce quickly from diamond loss.

Rotating direction of the blade in the installation process see: → Chap. 5.1, page 17

Synthetic resin based thin wheel cut of blades must not be exposed to moisture. The water connection for wet cutting must not be used when using synthetic resin cut off blades. Synthetic resin blades must not be used in high humidity or in rain. Only use synthetic resin blades until the end of the best-before date imprinted on the blade blotter or shipping box.

The power tool's spindle is designed for cutting discs with an inner bore of 20 mm.

Blades with an 1" inner bore must only be installed with the spindle adapter provided with the CE414-350. Using other spindle adapters may not allow the blade to be properly secured to the machine.

Installation of blades with 1" inner bore see: → Chap. 5.1, page 14

Blades with other inner bores must not be installed!

New blades must be tested for at least 60 seconds at the indicated maximum speed before the first cutting process. Take care that no body parts are in the path of the blade.

6.2 Permissible Cutting Area and Danger From Kickback or Drawing Along

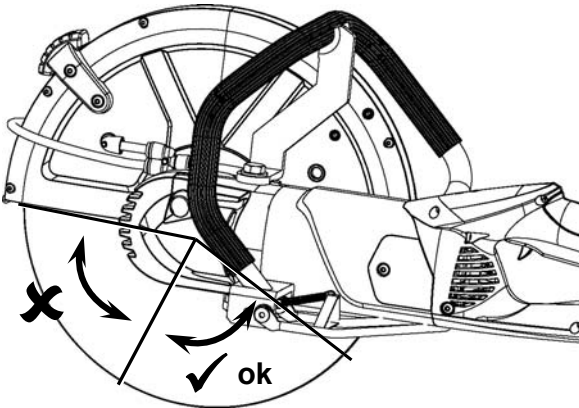

✘ The upper part of the blade must not be used for cutting!

✓ Only the lower part of the blade can be used for cutting!



Danger of injury from kickback!

Kickback results when the upper part of the blade is used for cutting.

The power tool can be pushed towards the user's causing loss of operator control which can result in injury.

- Never cut with the upper area of the blade!
- Take special care at insertion into cutting areas already started!



Danger of injury from drawing along!

Drawing along results when the cutting path becomes very narrow or from pinching the blade and the power tool is pulled away from the operator.

The power tool can accelerate away from the operator at high speeds and can result in injury.

- Always perform cutting at full rpm and repeated insertion into the cut at points already started.
- Always support the work piece so that the cutting point does not move and so that the cutting blade is not clamped or pinched.
- When starting a cut, always carefully move the cutting blade to the work piece; do not force the blade into the work.
- Only cut one item at a time!
- Ensure that no other work piece is touched when cutting.

6.3 Working Behaviour and Working Technique

- For complex cutting processes, cutting direction and order of the cuts to be performed must be specified in advance to prevent clamping of the cutting blade by the moving debris or injury from dropping parts.
- Always hold the power tool with both hands. Have the one hand on the rear handle, and the other hand on the top handle. Firmly grasp the handles with your thumb.
- Operate the power tool at full speed whenever cutting.
- Direction change, side pressure or tilting of the power tool during cutting is forbidden and can cause kick back or drawing along – both of which can result in injury.
- When shortening work pieces use a secure support and secure the work piece against slipping and twisting. The work piece must not be held with your foot or by another person.
- Always be ready for sudden kickback of the work piece and the possibility of quickly moving away from the work area.
- Observe that debris coming out of the cut can cause injury and property damage.

6.4 Cutting Metal



Always wear breathing protection when dry cutting.

Due to friction created by the rotating cutting blade metals are heated to extremely high temperatures. Be aware of hot flying sparks, and that the blade and material will be hot enough to cause personal injury or catch objects on fire.

- Swivel the blade guard down as far as possible for sparks to fly forward where possible, i.e. away from the user.
- Before cutting, specify and mark the cutting line, and approach the material with the blade at full speed.
- Only cut straight and vertically. Do not tilt.
- For a secure and smooth cut, it is best to push or move the power tool forward (away from the operator) in a controlled fashion (step cutting). When moving the power tool forwards, do not force the blade into the material.
- Large diameter round rods are best cut in steps.
- Thin tubes can be cut with a single sinking cut (plunge).
- Tubes with large diameters should be treated like large diameter rods. To avoid tilting and for better control of the cutting process, do not let the blade plunge into the material too far. Always cut flat around.
- I-beam or angled steel should be cut in steps.
- Steel bands or steel plates are cut like tubes; pulling flat with long cutting area.
- Material under tension (supported or material in a wall) always has to be grooved slightly on the pressure side and then cut from the pulling side so that the cutting disc is not clamped.

6.5 Cutting Concrete/Masonry Materials

Lots of fine dust occurs when cutting mineral materials such as block, brick, concrete, asphalt, and stone. We recommend that you use the water connection of the power tool when cutting mineral materials, and to use cutting discs suitable for wet cutting.

When cutting with water supply, the dust is bound, visual inspection is improved and the cutting disc service life is increased by the cooling effect of the water.

Water connection for wet cutting: →Water Chap. 5.3, page 15

Mineral materials are torn out at the point of contact and ejected from the cutting groove by the fast rotation of the cutting blade.

- Swivel the Blade Guard down as far as possible to protect the operator from cut particles.
- Mark the cutting line and cut a groove of approx. 3/16" (5mm) deep along the entire line with the motor running at full speed. This groove will be used as a guide during subsequent cuts.
- Perform the cutting process with even movements forward and back.
- When cutting thin pieces of stone, it may not be possible to cut completely through the stone without pinching the blade. In this case cut as deep as possible and then break the stone in half on a flat support.
- For best performance step cut.
- Do not force the blade into the cut.

7 Operating and Maintenance Notes



Maintenance, service, and repairs of all state-of-the-art power tools must be done by a qualified service technician. Some maintenance, service and repairs may require specialized tools and training. We recommend all work to be performed by the Norton Clipper selling Distributor or Norton Clipper Authorized Service Center. We also recommend that all work not described in these operating instructions and all work you are not comfortable with be performed by the Norton Clipper selling Distributor or Norton Clipper Authorized Service Center. The Norton Clipper selling Distributor or Norton Clipper Authorized Service Center technicians have the required training, experience, and equipment and can make the most cost-efficient solution available to you. He will advise and support you. For the nearest Norton Clipper selling Distributor or Norton Clipper Authorized Service Center please contact customer service at 1-800-554-8003.



Observe ALL safety instructions before beginning any maintenance, service, or repair work!



After a run-in time of approx. 5 operating hours, all screws and nuts that can be reached must be checked for tight fit and tightened again if required.

It is best to keep the power tool in a dry and safe location when not in use. Do not allow the power tool motor, switch, or electrical connections to become wet.

7.1 Cleaning and Care



This power tool must be cleaned thoroughly after each work day and inspected for damage; in particular the cooling air openings around the brushes, power switch, and blade guard, material deposits will form over time (in particular when wet cutting), which may impair free rotation of the cutting disc.

Only use the environmentally friendly cleaning products that are safe for Nylon, Plastics, Aluminium, and Magnesium. Never use fuel to clean!

NEVER pressure wash any electrical power tool.

- Remove material deposits from inside the blade guard with a piece of wood or similar object that will not damage the blade guard.
- Clean and inspect the blade shaft (spindle) and blade collars (flanges).
 - The blade collars should be one piece, flat with recess, free of all debris and all foreign material, free of damage, and are the correct size.

- Clean the blade and check it for damage. If any damage is found, replace the blade immediately and dispose of the blade so that it cannot be reused.

Regular Service Period Performed At Every Indicated Period →		After First Hour of Work	Beginning Of Day	During Blade Change	End Of Day	Once A Week	After Failure	After Damage
		Whole Machine	Inspect For Damaged or Missing Components	X	X	X	X	X
	Clean		X			X		
Blade Collars	Clean			X				
Water Hose, Water Fittings, and Nozzles	Clean		X			X		
	Inspect		X			X		X
Reachable Hardware	Tighten					X		

7.2 Replacing the Carbon Brushes



This electrical power tool is powered by a high horsepower low amperage air over brush motor. Replace the brushes when the motor begins to lose power. Brushes will typically need to be replaced during the life of the saw. Replace the brushes when over 2/3 of their original length is used (when the overall length of the brushes is less than 7/16" (11.1mm)). It is normal for the brushes to wear down.

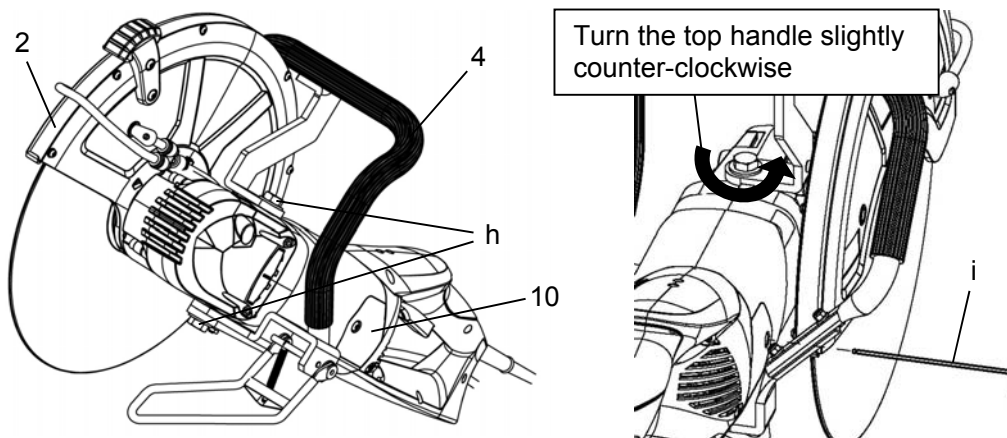

Brush replacement:

- Disconnect the electrical supply.
- Loosen the two bolts (h) slightly on the top handle.
- Turn the top handle slightly counter clockwise as shown above to give the brush cover on the protective cowl (2) side of the power tool room for removal.
- Using a 3mm hex key wrench (i) to open the carbon brush cover on both sides of the tool.

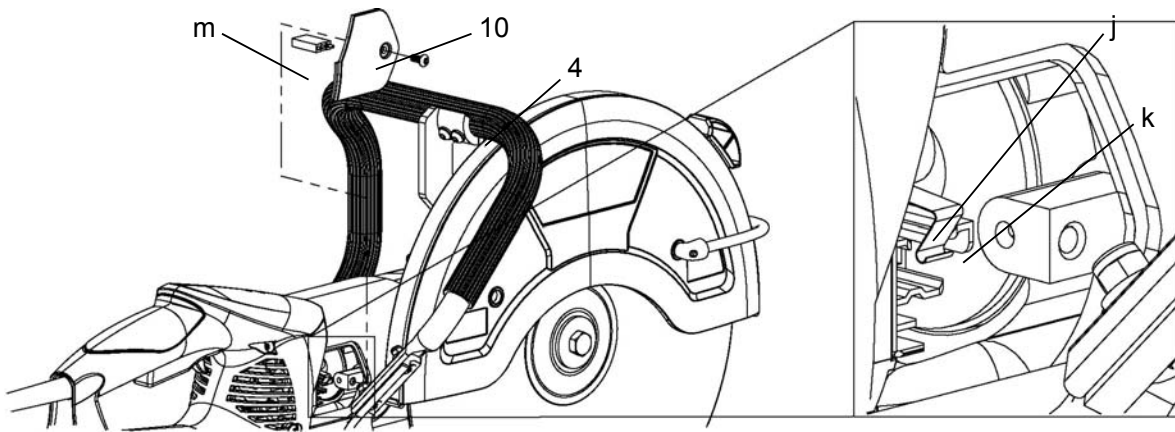

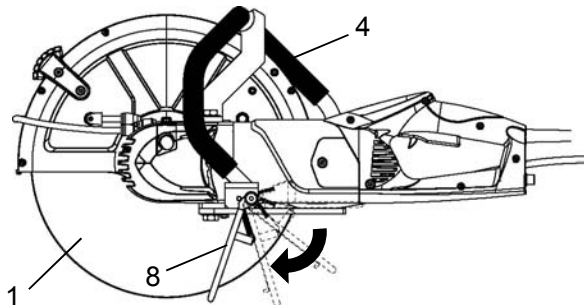

- Pull the compression spring back (j) and to the side so that it rests on either side of the carbon brush holder (k).
- Remove the carbon brushes (m). Use compressed air to remove any carbon build-up on the armature and to check for any signs of excessive wear. The armature can be rotated by hand by carefully turning the commutator (element the carbon brushes were pressed against) with your finger. Be careful not to leave any greasy residue on this surface.
- Place the new carbon brushes into the carbon brush holder (k).
- Reinstall the carbon brush covers.
- Return the top handle (4) into its correct position. Retighten the mounting bolts (h).

7.3 Using the Kick Stand



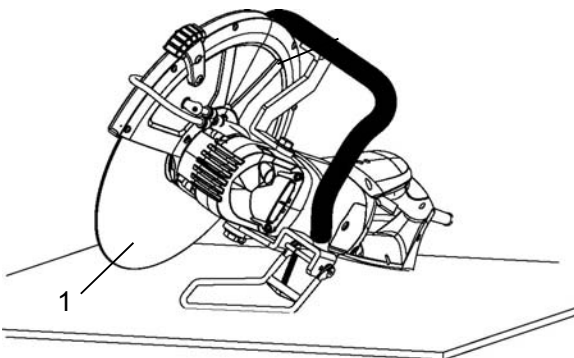

This power tool is packaged with a Kick Stand (8) retracted. With the one hand hold the tool by the top handle (4), if the saw has been used the cutting blade (1) should no longer be in motion, use your other hand to deploy the Kick Stand (8). Hold the machine as close to the center brace as possible, designated with a vertical arrow on the left. This position provides the best balance for this tool during transportation.

  When manipulating the Kick Stand (8) the cutting blade (1) must not be moving



Place the power tool down on the ground as shown on left. Even when leaned over, this machine is very stable. Do not attempt to set the machine down until the cutting blade (1) has stopped moving. Using the Kick Stand will prevent unintentional damage to your equipment by reducing its foot print in your work space. Furthermore the cutting blade and the motor body are easier to maintain while in this position.

  Before setting the power tool down on the Kick Stand, wait until the cutting blade (1) is no longer moving.

8. Warranty

Saint-Gobain Abrasives, Inc. (Norton Clipper) Products warrants the CE414-350 manufactured by it against defects in workmanship or materials for a period of six (6) months the date of shipment to the customer.

The responsibility of Saint-Gobain Abrasives, Inc. under this warranty is limited to replacement or repair of defective parts at Saint-Gobain Abrasives, Inc. Stephenville, Texas factory, or at a point designated by it, of such part as shall appear to us upon inspection at such point, to have been defective in material or workmanship, with expense for transportation borne by the customer.

In no event shall Saint-Gobain Abrasives, Inc. be liable for consequential or incidental damages arising out of the failure of any product to operate properly.

This warranty is in lieu of all other warranties, expressed or implied, and all such other warranties are hereby disclaimed.

Please understand that we cannot assume any warranty for the following damage causes:

- Non-observance of the operating instructions
- Omission of necessary maintenance and cleaning work.
- Damage due to improper voltage.
- Wear from regular use.
- Obvious overload because the upper performance limit is exceeded continually.
- Use of other than approved service parts.
- Application of force, improper treatment, misuse or accident.
- Overheating damage due to contamination at the fan housing.
- Repairs or service by persons who are not authorized by Saint-Gobain.
- Use of unsuitable spare parts or other than original parts if they caused the damage.
- Use of unsuitable or incorrect blade for application.
- Damage due to the usage conditions from renting.

Cleaning, care and adjustment are not deemed warranty services.

Warranty services must be performed by a authorised Norton Clipper service center.

9. Service parts

Several components are subject to wear in operation or regular wear and may have to be replaced in time. The following wear parts are not subject to the manufacturer's warranty:

- Operating materials
- Air filter
- Air Filter Holder
- Brushes
- Brush Caps

NOTES.



Saint-Gobain Abrasives

2770 West Washington
Stephenville, TX 76401
Phone: 254-918-2310
Fax: 254-918-2312



elipper®

WARNING

Some dust created by power sanding, sawing, grinding, drilling, and other construction activities contains chemicals known to cause cancer, birth defects or other reproductive harm. Some examples of these chemicals are:

- Lead from lead-based paints,
- Crystalline silica from bricks and cement and other masonry products, and
- Arsenic and chromium from chemically-treated lumber.

Your risk from these exposures varies, depending on how often you do this type of work. To reduce your exposure to these chemicals: work in a well ventilated area, and work with approved safety equipment, such as those dust masks that are specially designed to filter out microscopic particles.