



Operator's Instruction Manual

# SINGLE-DISC FLOOR GRINDER



**SEC-NG**



100 Thomas Johnson Drive, Frederick, MD 21702-4600 USA  
Phone: 301-638-3326 • 301-663-1600  
Fax: 800-447-3326 • 301-663-1607  
edcoinc.com • sales@edcoinc.com



**READ AND UNDERSTAND THE OPERATORS INSTRUCTION MANUAL THOROUGHLY BEFORE ATTEMPTING TO OPERATE THIS EQUIPMENT.**



**Death or serious injury could occur if this machine is used improperly.**



**SAFETY MESSAGES**

- Safety Instructions are preceded by a graphic alert symbol of DANGER, WARNING, or CAUTION.



Indicates an imminent hazard which, if not avoided, will result in death or serious injury.



Indicates an imminent hazard which, if not avoided, can result in death or serious injury.



Indicates hazards which, if not avoided, could result in serious injury and or damage to the equipment.

**GASOLINE/PROPANE POWERED EQUIPMENT**



- Engine exhaust from this product contains chemicals known to the State of California to cause cancer, birth defects or other reproductive harm.



- Gasoline is extremely flammable and poisonous. It should only be dispensed in well ventilated areas, and with a cool engine.

- Small gasoline engines produce high concentrations of carbon monoxide (CO) example: a 5 HP 4 cycle engine operation in an enclosed 100,000 cu. ft. area with only one change of air per hour is capable of providing deadly concentrations of CO in less than fifteen minutes. Five changes of air in the same area will produce noxious fumes in less than 30 minutes. Gasoline or propane powered equipment should not be used in enclosed or partially enclosed areas. Symptoms of CO poisoning include, headache, nausea, weakness, dizziness, visual problems and loss of consciousness. If symptoms occur - get into fresh air and seek medical attention immediately.

**ELECTRICAL POWERED EQUIPMENT**



Extreme care must be taken when operating electric models with water present: Ensure power cord is properly grounded, is attached to a Ground-Fault-Interrupter (GFI) outlet, and is undamaged.

- Check all electrical cables - be sure connections are tight and cable is continuous and in good condition. Be sure cable is correctly rated for both the operating current and voltage of this equipment.
- Improper connection of the equipment-grounding conductor can result in a risk of electric shock. Check with qualified electrician or service person if there is any doubt as to whether the outlet is properly grounded. Adhere to all local codes and ordinances.
- **NOTE:** In the event of a malfunction or breakdown, grounding provides a path of least resistance for the electric current to dissipate. The motor is equipped with a grounded plug and must be connected to an outlet that is properly installed and properly grounded. **DO NOT** modify the plug provided on the motor. If the plug does not fit the outlet have a qualified electrician install the proper receptacle.
- Switch motor OFF before disconnecting power.

- Do not disconnect power by pulling cord. To disconnect, grasp the plug, not the cord.
- Unplug power cord at the machine when not in use and before servicing.

**GENERAL INSTRUCTIONS**

- Equipment should only be operated by trained personnel in good physical condition and mental health (not fatigued). The operator and maintenance personnel must be physically able to handle the bulk weight and power of this equipment.
- This is a one person tool. Maintain a safe operating distance to other personnel. It is the operators' responsibility to keep other people (workers, pedestrians, bystanders, etc.) away during operation. Block off the work area in all directions with roping, safety netting, etc. for a safe distance. Failure to do so may result in others being injured by flying debris or exposing them to harmful dust and noise.
- This equipment is intended for commercial use only.
- For the operator's safety and the safety of others, always keep all guards in place during operation.
- Never let equipment run unattended.



- Personal Protection Equipment and proper safety attire must be worn when operating this machinery. The operator must wear approved safety equipment appropriate for the job such as hard hat and safety shoes when conditions require. Hearing protection **MUST** be used (operational noise levels of this equipment may exceed 85db). Eye protection **MUST** be worn at all times.



- Keep body parts and loose clothing away from moving parts. Failure to do so could result in dismemberment or death.

- Do not modify the machine.
- Stop motor/engine when adjusting or servicing this equipment. Maintain a safe operating distance from flammable materials. Sparks from the cutting-action of this machine can ignite flammable materials or vapors.

**DUST WARNING**



Some dust created by power sanding, sawing, grinding, drilling, and other construction activities contains chemicals known to cause cancer, birth defects, or other reproductive harm. Some examples of these chemicals are:

- Lead from lead-based paints, and
- Crystalline silica from bricks and concrete and other masonry products.

Your risk of exposure to these chemicals varies depending on how often you do this type of work. To reduce your risk: work in a well ventilated area, use a dust control system, such as an industrial-style vacuum, and wear approved personal safety equipment, such as a dust/particle respirator designed to filter out microscopic particles.



## SMI DUST AND SILICA WARNING

## A black rectangular icon with the word "WARNING" in white, bold, sans-serif capital letters.

Grinding/cutting/drilling of masonry, concrete, metal and other materials can generate dust, mists and fumes containing chemicals known to cause serious or fatal injury or illness, such as respiratory disease, cancer, birth defects or other reproductive harm. If you are unfamiliar with the risks associated with the particular process and/or material being cut or the composition of the tool being used, review the material safety data sheets and/or consult your employer, the manufacturers/suppliers, governmental agencies such as OSHA and NIOSH and other sources on hazardous materials. California and some other authorities, for instance, have published lists of substances known to cause cancer, reproductive toxicity, or other harmful effects.

Control dust, mist and fumes at the source where possible. In this regard use good work practices and follow the recommendations of the manufacturers/suppliers, OSHA/NIOSH, and occupational and trade associates. Water should be used for dust suppression when wet grinding/cutting/drilling is feasible. When the hazards from inhalation of dust, mists and fumes cannot be eliminated, the operator and any bystanders should always wear a respirator approved by NIOSH/OSHA for the material being used.

## A black rectangular icon with the word "WARNING" in white, bold, sans-serif capital letters.

Grinding/cutting/drilling of masonry, concrete and other materials with silica in their composition may give off dusts or mists containing crystalline silica. Silica is a basic component of sand, quartz, brick clay, granite and numerous other minerals and rocks. Repeated and/or substantial inhalation of airborne crystalline silica can cause serious or fatal respiratory diseases, including silicosis. In addition, California and some other authorities have listed respirable crystalline silica as a substance known to cause cancer. When grinding/cutting/drilling such materials, always follow the respiratory precautions mentioned above.



## Table of Contents

Safety and Warnings.....	2-3
Table of Contents.....	4
Specifications.....	5
Operating Controls .....	6
Getting started with your New Grinder .....	7-10
Operating Instructions.....	11-12
Attaching a Vacuum .....	13
Lubrication.....	13
Quick Change Multi-Accessory Disc .....	14-15
Maintenance Instructions .....	16
Maintenance Schedule.....	17
Notes.....	18
Limited Equipment Warranty.....	19



## SPECIFICATIONS

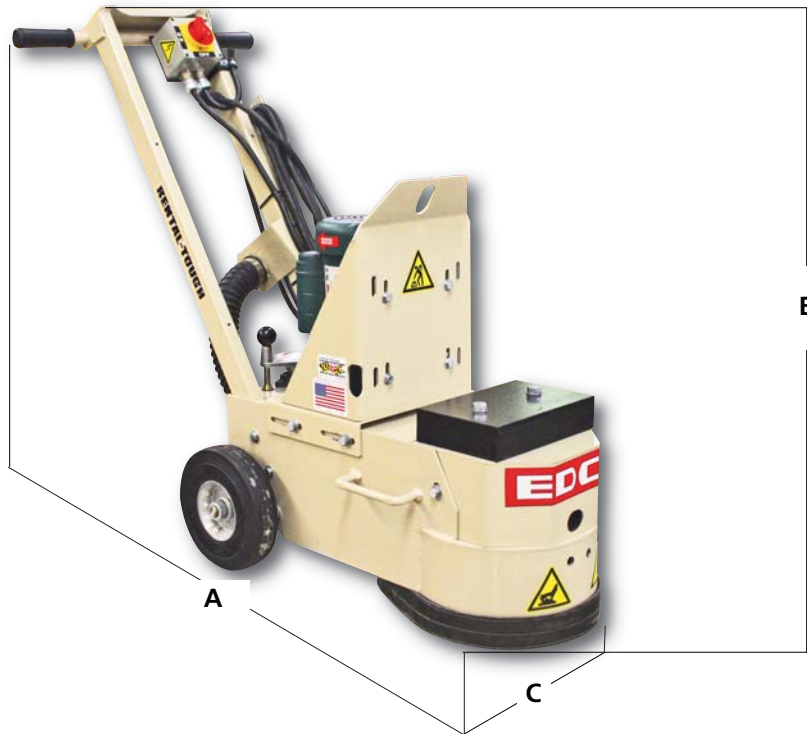

**NOTE:** All dimensions and weights are for reference only and subject to change at any time.

**Figure 1**

### HOW TO ORDER REPAIR PARTS

To insure product safety and reliability, always use genuine EDCO replacement parts when making repairs to the equipment.

When ordering parts, please specify the MODEL and SERIAL NUMBER of the machine as given on the NAMEPLATE. In addition, give part number, description and quantity as listed on the parts list.

Please note: Due to improvements and changes in the equipment the illustrations shown may be different from the actual machine.

Toll Free: Phone 1-800-638-3326 • Fax 1-800-447-3326

	SEC-H
"A"	42" 107cm
"B"	38" 97cm
"C"	22" 56cm
--	--
Head RPM	839
Weight	188 lbs/86kg



## OPERATING CONTROLS

### PLEASE NOTE:

Controls shown are for the model indicated.  
The location of these controls may vary on the different models.  
Due to improvements and changes in the equipment,  
the illustrations shown may vary from the actual machine.

## ELECTRIC MODEL

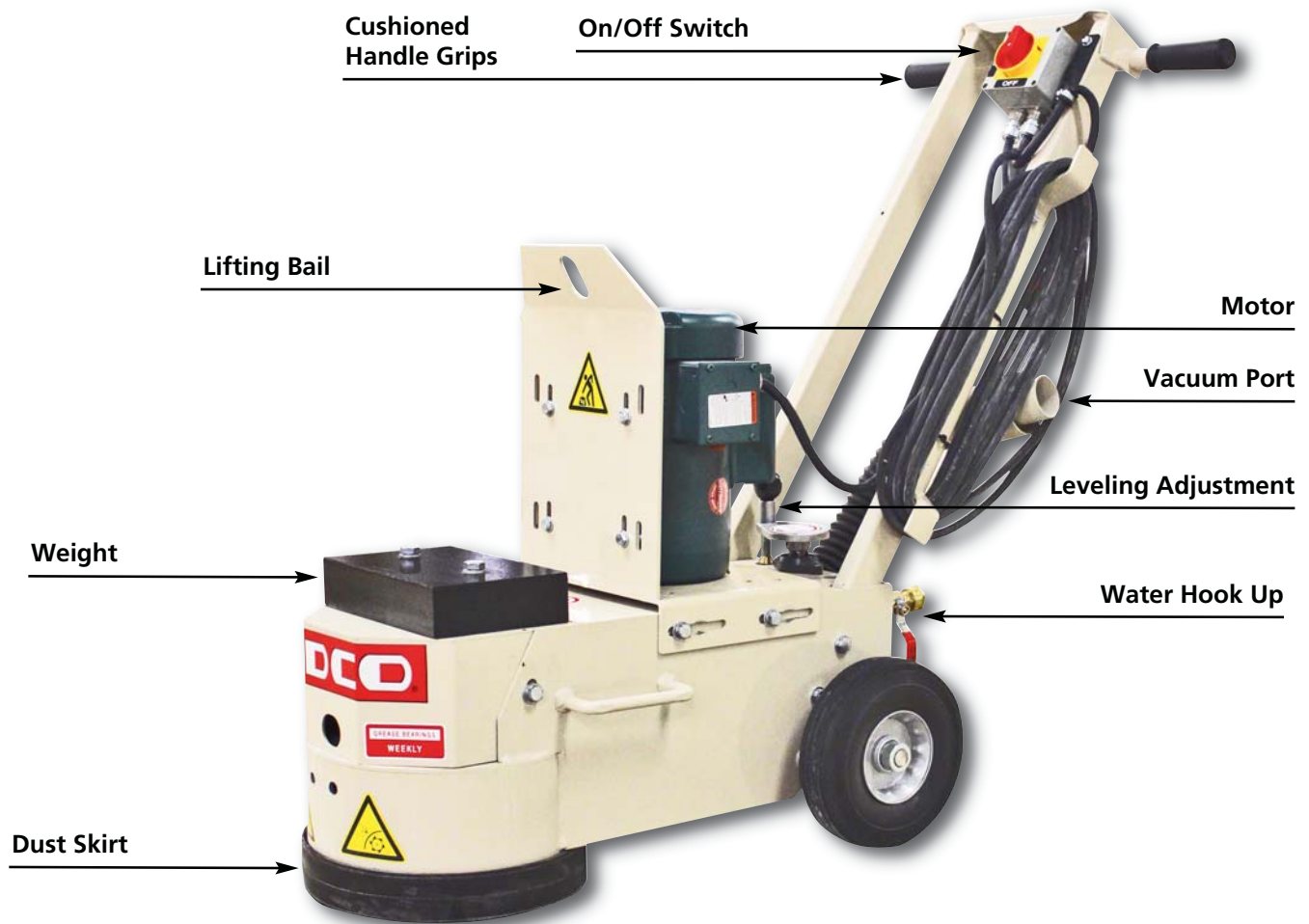

**Figure 2**



## GETTING STARTED WITH YOUR NEW GRINDER

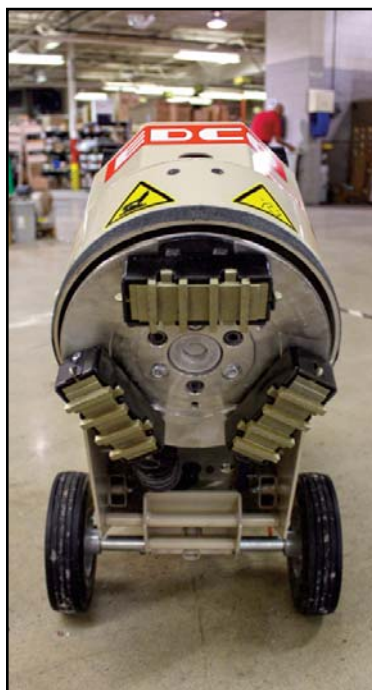

### 1. LOADING TOOLS:

Lean the machine back on the handle to expose the work area and load the proper tools for your job. Electric machines should be unplugged.

### LOADING TOOLS:

Once all tools are in the proper position return the machine to upright. Remember if you are using tools with PCD's or Strip-serts they have a leading edge and must be loaded as such. Also, remember the disc turns in the direction of arrow decal.

### CAUTION

Take care when loading tools. Edges of pockets are sharp.

**NOTE:** The above illustrations are viewing the Machine from the front bottom.  
**NOTE** the direction of rotation.



## GETTING STARTED WITH YOUR NEW GRINDER

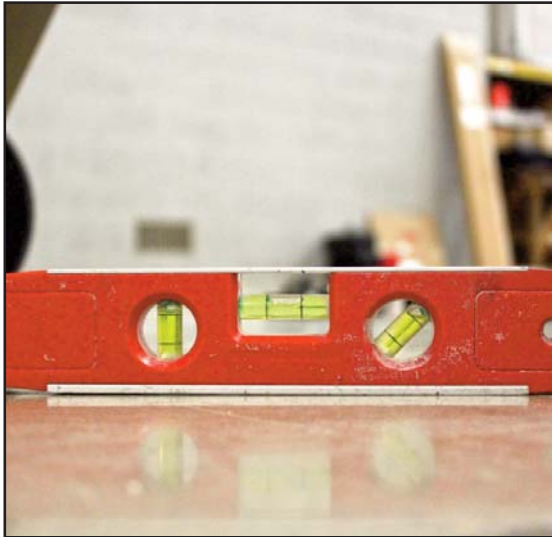

### BEGIN THE LEVELING PROCESS:

Check level of floor.



### BEGIN THE LEVELING PROCESS:

Lower machine to surface and match level. Adjust height by turning leveling handle in rear.



### BEGIN THE LEVELING PROCESS:

When leveling high profile tooling do not continue to turn handle past the level. Continued turning will disengage lower linkage from all thread.



### BEGIN THE LEVELING PROCESS:

Replace skirt leaving approximately 1/8" clearance above floor.





## GETTING STARTED WITH YOUR NEW GRINDER



### LEVELING:

Lean back slightly on the handle to get the tools off the surface and start the machine. Lower the machine to the surface and do a short touch pass on the concrete.



### LEVELING:

You are looking for a complete circle.



### LEVELING:

If you see a partial circle repeat the leveling process until complete circle is achieved.



## GETTING STARTED WITH YOUR NEW GRINDER



### LEVELING:

The bubble on the machine will not necessarily be centered once optimum operating position is achieved. It will also float back and forth during grinding. Level on your machine may not be the same as pictured above.



### ATTACH THE SKIRT:

Spacing approximately 1/8" off surface for best vacuum performance.

**FINAL NOTE:** If you are using tools that have no directionality they should be rotated occasionally for longer life and the machine should be readjusted as needed.



## OPERATING INSTRUCTIONS



- Read and understand all operating instructions before operating this equipment. Death or serious injury can result if this machine is used improperly.
- Concrete grinders are designed to be used to grind flat horizontal concrete slabs using EDCO approved accessories.
- The machines are equipped with electric motors.
- They are designed to be controlled by a single operator from a position at the rear of the machine.
- When operating equipment maintain a safe distance from other personnel in the area.

### BE SURE TO READ THE COMPLETE INSTRUCTIONS SUPPLIED WITH YOUR MACHINE

#### IMPORTANT: Perform Pre-Start Check

- Visually inspect the equipment for wear or damage.
- Be sure all guards are in place and functioning properly. Do not operate unless all guards are in place and secure.
- Perform all daily maintenance.
- Check to be sure water tubes are functioning properly if performing wet-grinding operations.
- Inspect accessories - Be sure the correct accessory is installed properly on the machine, mounting arrangement and its intended use.
- Check accessories for damage (see figure 6, below), the type of wear or damage will vary with the type of accessory.
- Inspect work area to determine the presence and location of deck inserts, pipes, columns and objects protruding from the slab surface so that they may be avoided during the grinding operation.
- FOR WET GRINDING: Attach the water supply. A flow rate of approximately 1/2 gallon per minute is recommended.

EXAMPLE OF SEVERLY WORN DYMA-SERT	EXAMPLE OF AN EVENLY WORN DYMA-SERT
	
<p>The above is an example of a DYMA-SERT that has not been rotated after every four hours of use. To get maximum life out of a DYMA-SERT they should be rotated 180° every four hours of use.</p>	<p>The above is an example of a DYMA-SERT that has been rotated after every four hours of use, as you can see the <i>wear is even</i> across all segments.</p>

Figure 6



## OPERATING INSTRUCTIONS

- **BEFORE STARTING THE MOTOR:** Raise the front of the machine clear of the working surface.
- **START MOTOR AND ALLOW IT TO REACH OPERATING SPEED:** Position the grinder at the starting point. Bring the motor to full speed. Lower the machine onto the slab surface. Use a slow sweeping motion from left to right and back continuously, and do not force the machine into the work, the motor should not strain when grinding.
- **WHEN WET GRINDING:** Water is required. Attach the water hose to the water hook-up valve. Use the valve to control the water flow.
- **FOR DRY GRINDING:** Provide a respirator and dust control system.
- **TO STOP THE MACHINE:** Stop forward motion, tilt machine to raise off of floor. Turn power switch off and let the motor come to a complete stop. Turn off the water supply.
- **WHEN MANEUVERING THE GRINDER:** Tilt grinder back enough so it does not strike the slab surface. Damage to accessories may occur with inadvertent contact with slab.
- **DO NOT FORCE GRINDER WHILE GRINDING**
- **IF THE POWER SOURCE FAILS:** Raise the grinder off of the floor. Disconnect the power source. Inspect the accessories for damage. Replace damaged (or questionable) accessories immediately.
- **WHEN TRANSPORTING THE GRINDER:** Disconnect the power source before lifting or removing any guards. Remove accessories when transporting.
- **WHEN HOISTING OR LIFTING A GRINDER:** Always inspect frame and attaching hardware for damage before lifting. Use proper safe hoisting and lifting techniques and hardware.

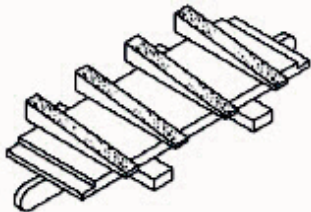
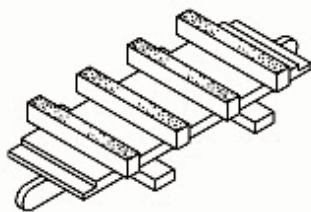

## ATTACHING A VACUUM / SERVICING HEAD ASSEMBLY



### PROCEDURE FOR ATTACHING A VACUUM:

If using a vacuum for dust control attach it to the vacuum port at the rear of the machine which is on the handle as pictured above, securing it with clamps. The port is shown in the above photo.



### FOR LUBRICATION:

Grease fittings are now available through access port in hood.



## FOR USE WITH QUICK-CHANGE MULTI-ACCESSORY DISC

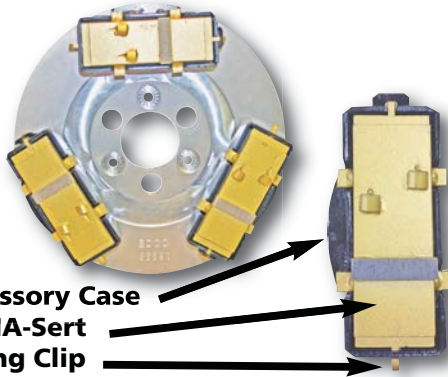

Accessory Case  
DYMA-Sert  
Spring Clip

### PCDyma-SERTS™

Makes quick work of epoxy coatings and hard glue - Ideal for the removal of hard and tacky surfaces including urethane epoxy, multi part epoxy, waterproofing membrane, pool deck coating, thick membrane, thick mastics, old and new epoxy coatings.

4 times stronger than carbide with incredible removal capabilities.

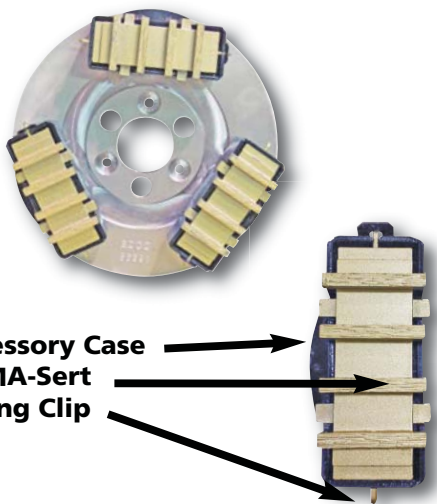

Accessory Case  
DYMA-Sert  
Spring Clip

### Dyma-SERTS™

Grind 5 times faster than grinding stones and lasts longer - up to 30,000 sq ft (2,800 sq m) of grinding action on standard 3,500 PDI concrete. Dyma-Serts can be used for wet or dry grinding.

Ideal for the removal or smoothing of rough surfaces or trowel marks, grinding terrazzo, repairing surface damage to concrete slabs, removing urethane or epoxy thincoats, grinding sharp aggregates such as flint and granite, removing surface imperfections from epoxy mortars, leveling high spots, removing thin mastics and thin-set.

5 times faster than grinding stones. Long Lasting!

Rotate the Dyma-SERTS™ only, not the case.

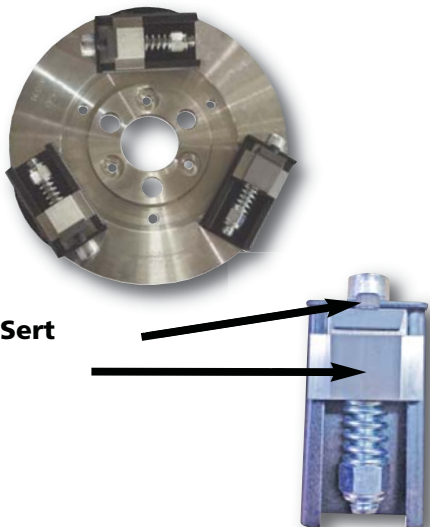

Hex Screw  
STRIP-Sert

### STRIP-SERTS™

Carbide tipped blocks are designed to clean floors without grinding into the concrete. STRIP-SERTS™ have a replaceable, multi-sided tungsten carbide edge that can be rotated for maximum use. Removes surface build-ups without grinding into the surface below.

Ideal for the removal of mastics, paints, resins, tar, fiberglass, ice and industrial buildups.

Use a hex wrench to remove hex screw to allow rotation of blade. Rotate this blade to expose a new cutting surface. There are four cutting surfaces on each blade.



## FOR USE WITH QUICK-CHANGE MULTI-ACCESSORY DISC

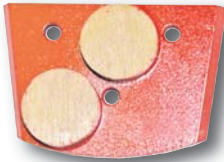

**DOUBLE DYMA-DOTS:** General Purpose Grind - Removes general purpose epoxy, mastics, thinsets, water-proofing coatings and more.



**SINGLE DYMA-DOTS:** Aggressive Grind - Grinds and removes thick epoxies, weather-proofing membrane and other coatings.

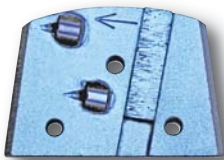

**DYMA-PCD ACCESSORY:** Extremely Aggressive Removal - Digs through industrial strength coverings, water-proofing membranes, thick epoxies and much more - *Leaves a textured concrete surface.*

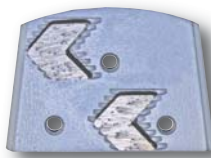

**DYMA-ARROW:** Hard glue removal, fast coating removal, create smooth surfaces and more.



**DYMA-PEAKS:** General Purpose Grind - Smooths surfaces with fewer scratches - Ideal for concrete preparation and polishing. Removes thinsets, concrete coatings and more.



## MAINTENANCE INSTRUCTIONS



1. Disconnect the machine from the power source. Disconnect the supply voltage connector at the machine on electric models before performing any maintenance. All maintenance to be performed by qualified personnel.

2. Never work under equipment without first properly securing the equipment to prevent it from moving or falling. Always work on a flat and level surface.

3. Perform a visual inspection of the entire machine before each operation. Be sure all fasteners are tight and secure, check for signs of metal cracking or fatigue, inspect for damage to electrical wiring, and inspect to be sure proper guards are in place and secure.

4. Before operation, check grinding discs to be sure they are tight. Grinding discs loosen with use. Tighten bolts as required.

An occasional drop of two of oil on the wheel bearings will help prevent binding.





## MAINTENANCE SCHEDULE

	Before Operation	Every 4 Hours	Daily	Every 50 Hours of Operation	As Required
Visual Inspection of Entire Machine			<b>X</b>		
Inspect Grinding Discs	<b>X</b>				
Clean Dust & Dirt Off Machine					<b>X</b>

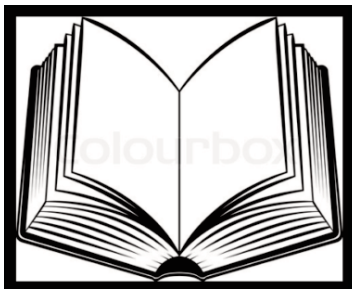

**Read and follow all instructions in the Engine Manufacturer's Owners Manual.**

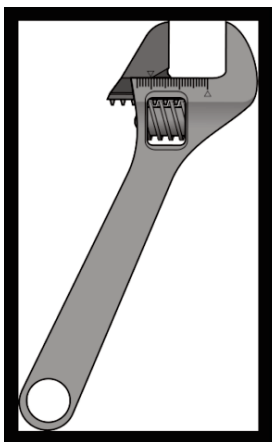

**Repairs are to be performed by approved EDCO repair technicians.**





## LIMITED EQUIPMENT WARRANTY OF SALE – TERMS & CONDITIONS

Equipment Development Company, Inc. herein referred to as EDCO (Seller) warrants that each new unit manufactured by EDCO to be free from defects in material and workmanship in normal use and service for a period of (1) one year (except for the cutter drum assembly on all model concrete/asphalt planes, in which case the warranty period shall be 90 days) from date of shipment to the original retail or equipment rental center owner.

Accessories or equipment furnished and installed on the product by EDCO but manufactured by others, including, but not limited to engines, motors, electrical components, transmissions etc., shall carry the accessory manufacturers own warranty.

EDCO will, at its option, repair or replace, at the EDCO factory or at a point designated by EDCO, any part which shall appear to the satisfaction of EDCO inspection to have been defective in material or workmanship.

EDCO reserves the right to modify, alter and improve any part or parts without incurring any obligation to replace any part or parts previously sold without such modified, altered or improved part or parts.

This warranty is in lieu of and excludes all other warranties, expressed, implied, statutory, or otherwise created under applicable law including, but not limited to the warranty of merchantability and the warranty of fitness for a particular purpose in no event shall seller or the manufacturer of the product be liable for special, incidental, or consequential damages, including loss of profits, whether or not caused by or resulting from the negligence of seller and/or the manufacturer of the product unless specifically provided herein. In addition, this warranty shall not apply to any products or portions thereof which have been subjected to abuse, misuse, improper installation, maintenance, or operation, electrical failure or abnormal conditions and to products which have been tampered with, altered, modified, repaired, reworked by anyone not approved by seller or used in any manner inconsistent with the provisions of the above or any instructions or specifications provided with or for the product

### FORCE MAJEURE

Seller's obligation hereunder are subject to, and Seller shall not be held responsible for, any delay or failure to make delivery of all or any part of the Product due to labor difficulties, fires, casualties, accidents, acts of the elements, acts of God, transportation difficulties, delays by a common carrier, inability to obtain Product, materials or components or qualified labor sufficient to timely perform part of or all of the obligations contained in these terms and conditions, governmental regulations or actions, strikes, damage to or destruction in whole or part of manufacturing plant, riots, terrorist attacks or incidents, civil commotions, warlike conditions, flood, tidal waves, typhoon, hurricane, earthquake, lightning, explosion or any other causes, contingencies or circumstances within or without the United States not subject to the Seller's control which prevent or hinder the manufacture or delivery of the Products or make the fulfillment of these terms and conditions impracticable. In the event of the occurrence of any of the foregoing, at the option of Seller, Seller shall be excused from the performance under these Terms and Conditions, or the performance of the Seller shall be correspondingly extended.

This document sets forth the terms and conditions pursuant to which the purchaser ("Purchaser") will purchase and Equipment Development Co. Inc. ("Seller") will sell the products, accessories, attachments (collectively the Products) ordered by the Purchaser. These terms and conditions shall govern and apply to the sale of Seller's Products to Purchaser, regardless of any terms and conditions appearing on any purchase order or other forms submitted by Purchaser to Seller, or the inconsistency of any terms therein and herein.

### 1. PRICE

All prices set forth on any purchase order or other document are F.O.B. Seller's facility or distribution point, as may be determined by Seller (F.O.B. Point). All prices are exclusive of any and all taxes, including, but not limited to, excise, sales, use, property or transportation taxes related to the sale or use of the Products, now or hereafter imposed, together with all penalties and expenses. Purchaser shall be responsible for collecting and/or paying any and all such taxes, whether or not they are stated in any invoice for the Products. Unless otherwise specified herein, all prices are exclusive of inland transportation, freight, insurance and other costs and expenses relating to the shipment of the Products from the F.O.B. point to Purchaser's facility. Any prepayment by Seller of freight insurance and other costs shall be for the account of Purchaser and shall be repaid to Seller.

### 2. PAYMENT TERMS

Payment terms are as follows. 2% 10 days (to approved and qualified accounts), Net 30 days. This is a cash discount for invoices paid within 10 days after the invoice date, regardless of date of receipt of shipment. This is not a trade discount and will not be granted to accounts that do not adhere to stated terms.

\*All past due accounts are subject to a late payment fee of 1.5% per month or a maximum allowed by law if different, along with the expenses incidental to collection including reasonable attorney's fees and costs.

\*Seller reserves the right to hold shipments against past due accounts.

\*Seller reserves the right to alter payment terms.

### 3. FREIGHT TERMS

All shipments will be made F.O.B. shipping point as designated in these Terms and Conditions, and title shall pass at the F.O.B. point. Delivery to the initial common carrier shall constitute delivery to the Purchaser. Any claims for loss or damage during shipment are to be filed with carrier by the Purchaser. Seller will not assume responsibility for the performance of the carrier.

Back orders will be shipped in the most practical fashion with charges consistent with our freight policy established with the original order. UPS, FED EX, MAIL or shipments by other couriers are subject to the same terms and conditions as outlined in paragraph #3 "Freight Terms".

### 4. DELIVERY, DAMAGES, SHORTAGES

Seller shall use reasonable efforts to attempt to cause the Products to be delivered as provided for in these Terms & Conditions. Delivery to the initial common carrier shall constitute the delivery to the Purchaser. Seller's responsibility, in so far as transportation risks are concerned ceases upon the delivery of the Products in good condition to such carrier at the F.O.B. point and all the Products shall be shipped at the Purchaser's risk. Seller shall not be responsible or liable for any loss of income and/or profits, or incidental, special, consequential damages resulting from Seller's delayed performance in shipment and delivery.

### 5. RETURN OF DEFECTIVE PRODUCTS

Defective or failed material shall be held at the Purchaser's premises until authorization has been granted by Seller to return or dispose of Products. Products that are to be returned for final inspection must be returned Freight Prepaid in the most economical way. Credit will be issued for material found to be defective upon Seller's inspection based on prices at time of purchase.

### 6. PRODUCTS ORDERED IN ERROR

Products may be returned, provided that claim is made and Seller is notified within 7 days of receipt of Products, and the Products are in original buyer's possession not more than 30 days prior to return, subject to Seller's approval. If Products are accepted for return, they must be Freight Prepaid and buyer will be charged a minimum of 15% restocking charge, plus a charge back for outbound freight charges if the original order was shipped prepaid. Returns are not accepted for any Products that are specifically manufactured to meet the buyer's requirement of either specifications or quantity.

### AGREEMENTS

These Terms and Conditions constitute the entire agreement between Seller and Purchaser as it relates to terms and conditions of sale, and supersedes any and all prior oral or written agreements, correspondence, quotations or understandings heretofore in force between the parties relating to the subject matter hereof. There are no agreements between Seller and Purchaser with respect to the Product herein except those specifically set forth in and made part of these terms and conditions. Any additional terms, conditions and/or prices are rejected by Seller.

These terms and conditions may be modified, cancelled or rescinded only by a written agreement of both parties executed by their duly authorized agents.

**USE ONLY GENUINE EDCO PARTS & ACCESSORIES**  
**For your own safety, the safety of others and the life of your machine.**



**SURFACE PREPARATION, RESTORATION, PROFESSIONAL  
SAWING EQUIPMENT & HAND HELD TOOLS**

**100 Thomas Johnson Drive, Frederick, MD 21702  
Phone: 1-800-638-3326 or 301-663-1600  
Fax: 1-800-447-3326 or 301-663-1607**

**Email: [sales@edcoinc.com](mailto:sales@edcoinc.com)  
Website: [edcoinc.com](http://edcoinc.com)**

**Patents Pending & Issued**



Printing 4.2015