

GB

ZOE ADV

30
YEARS
1974 - 2004



Use and maintenance manual



RAIMONDI S.p.A.

www.raimondiutensili.it

TABLE OF CONTENTS

CHAPTER 1 INTRODUCTION

1.1	DECLARATION OF CONFORMITY	3/40-1
1.2	TESTING, WARRANTY AND RESPONSIBILITY	4/40-1
1.3	ENVIRONMENTAL CONDITIONS	4/40-1
1.4	INTERVENTION REQUEST AND TECHNICAL SERVICE	5/40-1
1.5	SPARE PARTS ORDERS	5/40-1
1.6	MARKING	5/40-1

CHAPTER 2 SAFETY RULES

2.1	SAFETY GENERAL RULES	6/40-2
2.2	DEFINITION OF SAFETY-RELATED TERMS	7/40-2
2.3	CORRECT USE OF THE MACHINE	7/40-2
2.4	CHARACTERISTICS OF THE MACHINE	7/40-2
2.5	DESCRIPTION OF MACHINE GROUPS	9/40-2
2.6	POSITION OF THE OPERATOR	10/40-2
2.7	SAFETY DEVICES	10/40-2
2.8	ACCESSORIES OF THE MACHINE	10/40-2
2.9	NOISE	11/40-2
2.10	VIBRATIONS	12/40-2
2.11	DEMOLITION AND DISPOSAL	13/40-2
2.12	CE MANUFACTURER'S DECLARATION	13/40-2

CHAPTER 3 HANDLING, INSTALLATION, ADJUSTMENTS

3.1	PACKING TRANSPORT	14/40-3
3.2	MANUAL HANDLING	14/40-3
3.3	POWER SUPPLY	15/40-3
3.4	ASSEMBLY OF THE MACHINE	16/40-3
3.4.1	TANK FILLING	17/40-3

CHAPTER 4 USE OF COMMANDS

4.1	PRELIMINARY OPERATIONS BEFORE CUTTING	18/40-4
4.1.1	DIAMOND BLADE EXTERNAL PROTECTION	18/40-4
4.2	CUTTING	19/40-4
4.3	DIAGONAL CUTS	21/40-4
4.4	45° JOLLY CUTS	21/40-4
4.5	DIAMOND BLADE SHARPENING	23/40-4
4.6	SQUARE ADJUSTMENT	23/40-4
4.6.1	SUPPORT ALIGNMENT	25/40-4
4.7	SLIDING DEVICE ADJUSTMENT	25/40-4

CHAPTER 5 MAINTENANCE INTERVENTIONS

5.1	BLADE REPLACEMENT	26/40-5
5.2	RECYCLE PUMP REPLACEMENT	27/40-5
5.3	STARTER REPLACEMENT	28/40-5
5.4	STARTING DEVICE REPLACEMENT	28/40-5
5.5	TANK EMPTYING AND CLEANING	29/40-5

CHAPTER 6 ACCESSORIES

6.1	ACCESSORIES	31/40-6
6.2	TILE STOPPING DEVICE	31/40-6
6.3	EXTENSION BENCHES	31/40-6
6.4	SET-SQUARE	32/40-6
6.5	ROLLING SIDE TABLE	32/40-6

CHAPTER 7 DIAGNOSTICS

7.1	TROUBLE-SHOOTING	33/40-7
-----	------------------	---------

CHAPTER 8 SPARE PARTS AND ELECTRIC DIAGRAM

8.1	SPARE PARTS	34/40-8
8.2	ELECTRIC DIAGRAMS	38/40-8

1.1 Declaration of conformity



The RAIMONDI S.p.A. company, with headquarters in Modena, Italy, Via dei Tipografi 11, represented by Mr. Ivan Raimondi as Legal Representative, declares under its sole responsibility that the machine named ZOE ADV, this declaration refers to, complies with the law provisions transposing the following Directives:

98/37/EEC	Machinery Directive
73/23/EEC	Low voltage Directive
89/336/EEC	Electromagnetic compatibility Directive
92/59/EEC	Directive on general product safety
85/374/EEC	Directive on Liability for defective products

Besides, it shall also be noted that, in the design and construction phases, the following technical standards have been complied with :

EN 12100-1	"Safety of machinery - Basic concepts, general principles for design: Terminology, methodology"
EN 12100-2	"Safety of machinery - Basic concepts, general principles for design: Technical principles"
EN 294	"Safety of machinery - Safety distances to prevent danger zones being reached by the upper limbs"
EN 418	"Emergency stop equipment"
EN 349	"Safety of machinery - Minimum gaps to avoid crushing of parts of the human body"
EN 1050	"Safety of machinery - Principles for risk assessment"
EN 842	"Safety of machinery - Visual danger signals - General requirements, Design and Testing"
EN 981	"Safety of machinery - System of auditory and visual danger and information signals"
EN 1037	"Safety of machinery - Prevention of unexpected start-up"
EN 811	"Safety of machinery - Safety distances to prevent danger zones being reached by the lower limbs"
EN 894-1	"Safety of machinery - Ergonomics requirements for the design of displays and control actuators Part 1: general principles for human interactions with displays and control actuators "
EN 894-2	"Safety of machinery - Ergonomics requirements for the design of displays and control actuators Part 2: Displays"
EN 894-3	"Safety of machinery - Ergonomics requirements for the design of displays and control actuators Part 3: Control actuators"
EN 953	"Safety of machinery - General requirements for the design and construction of fixed and movable guards"
EN 60204-1	"Electrical equipment of machines"
UNI EN 12418	"Masonry and stone cutting-off machines for job site. Safety "

Modena 12/09/2007

Ivan Raimondi

A handwritten signature in red ink, appearing to read 'Ivan Raimondi', is written over the printed name.

1.2 Testing, warranty and responsibility

Testing

The whole machine is sent to the customer ready for the installation, after passing the tests provided for by the manufacturer, in compliance with the laws in force.

Warranty

During the 12-month warranty, RAIMONDI S.p.A. undertakes to supply, free of charge, those parts of its production found to be defective, in terms of material or processing.

Such parts will have to be returned to RAIMONDI S.p.A., shipped carriage free.

By warranty, we mean supply of defective parts, if any.

The warranty does not cover all the expenses as to travel, board, lodging, transport and manpower concerning the replacement of parts by the RAIMONDI S.p.A. technicians, which will be charged entirely on the Customer.

The warranty does not cover all the parts subject to wear.

As to purchased components, the supplier warranty will apply.

No compensation will be granted for expenses, damages or loss of profits incurred by customer.

Installation of purchased parts not complying with the specifications of RAIMONDI S.p.A., if purchased or not supplied by RAIMONDI S.p.A., if manufactured by it, as well as improper use of the machine, will make the warranty null and void.

Responsibility

RAIMONDI S.p.A. is in no case responsible for operation anomalies or generic failures, caused by unauthorized use of the machine or by interventions and/or modifications carried out by external persons not authorized by RAIMONDI S.p.A. itself.

1.3 Environmental conditions

The environmental working conditions of the machine shall comply with the following indications:

Temperature	0°C ÷ +55°C	32°F ÷ 131°F
Humidity	10% ÷ 90% (not condensed)	104°F



THE MACHINE SHALL BE POSITIONED IN PREMISES PROPERLY PROTECTED FROM THE RAIN

Environmental conditions other than those specified herein can cause serious damage to the machine and, in particular, to the electrical equipments.



POSITIONING THE MACHINE IN ENVIRONMENTS NOT COMPLYING WITH THE INDICATIONS HEREIN WILL MAKE THE WARRANTY NULL AND VOID

Storage of the machine, while not working, allows for a temperature variation ranging between -10°C and +70°C, all the other precautions still valid.



USE IN ENVIRONMENTS WITH EXPLOSIVE ATMOSPHERE OR FIRE RISK IS STRICTLY FORBIDDEN

1.4 Intervention request - Technical Service

Each intervention request to the Technical Service shall be send, by fax, to:

RAIMONDI S.p.A.

Technical Service

Telefax (39) 059 282 808

E.mail: raiutens@raimondiutensili.it

Specifying:

1. type of machine, registration number, serial number and year of installation;
2. detected defects;
3. retailer where the machine was bought.
4. receipt for item purchased certifying the date of purchase by the user

1.5 Spare parts orders

Each request of spare parts shall be sent, by fax, to:

RAIMONDI S.p.A.

Technical Service

Telefax (39) 059 282 808

E.mail: raiutens@raimondiutensili.it

specifying:

1. Machine model;
2. Registration number (see manual title page);
3. Code of the part to be ordered (see spare parts manual enclosed);
4. Requested quantity;
5. Shipping modality;

1.6 Marking

The machine identification data are engraved on the plate and shall always be indicated on every communication document exchanged between the user and the manufacturing company, for example in every assistance request or request of spare parts, etc.

The identification plate is placed on the machines



**REMOVING OR TAMPERING WITH
THE IDENTIFICATION PLATE IS
STRICTLY FORBIDDEN.**

2.1 Safety general rules



THE RULES LISTED BELOW SHALL BE CAREFULLY READ AND SHALL BECOME THE CORE OF THE DAILY PRACTICE IN THE OPERATION AND MAINTENANCE OF ALL THE EQUIPMENT, WITH A VIEW TO PREVENTING ANY TYPE OF INJURY TO PEOPLE AND/OR DAMAGING OF OBJECTS.

1. Do not try to start the machine until its operation has been fully understood.
2. In case of doubts, despite having carefully and entirely read this manual, please contact the RAIMONDI S.p.A. Technical Service.
3. Make sure all the personnel involved in the use of machine are made aware of all the safety-related instructions.
4. Before starting the machine, the operator shall verify the possible presence of visible defects on the safety devices and on the machine. In this case, immediately inform RAIMONDI S.p.A. or the closest Technical service Centre on every evident breaking.
5. Never start the machine until all the personnel in the areas surrounding the machine have been warned and moved away.
6. Daily check the correct operation of all the safety devices and switches.
7. Safety devices shall never be removed nor made ineffective .
8. During maintenance, adjustment or repair interventions, it might be necessary to disable some of the safety devices. This operation shall be carried out by authorized personnel only.
9. All the plates and signs applied on the machine shall be kept in perfect conditions. In case of damage, they shall be promptly replaced.
10. The operator shall be familiar with the function and position of the **STOP** and **START** buttons.
11. Replace parts deemed to be broken with original spare parts, warranted by the manufacturing company.
12. Never try reckless solutions!
13. Any intervention on live parts shall be carried out by authorized personnel only, who will have to operate exclusively with the machine disconnected from the mains
14. Do not make any joint in the electrical connections of electric circuits.
15. Never intervene on moving parts, not even to unblock a jam.
16. Do not wear clothes, ornaments or accessories that might get entangled in the moving members.
17. Keep the area surrounding the machine clear.
18. Always wear protective glasses, hearing protectors and any other personal protection equipment in the areas where such equipment is required.
19. Always pay the greatest attention to all the warning and danger signs placed on the machine.
20. Always comply with and ensure compliance with the safety rules; in case of doubts, please consult this manual again before taking any action.
21. The machine shall be used exclusively for the uses it was intended for and in compliance with the provisions set forth in the contract with **RAIMONDI S.p.A.**



DO NOT USE THE MACHINE FOR USES OTHER THAN THOSE INDICATED IN THIS MANUAL. DO NOT HANDLE PRODUCTS OTHER THAN THOSE INDICATED IN THE MANUAL. DO NOT INCREASE THE MACHINE SPEED BEYOND THE VALUE INDICATED IN THE MANUAL.

Improper use of the machine can cause dangers for the personnel in charge of the machine operation and damage the machine it self.

For any problem that might arise during the machine life, and in any case not included in this manual, please contact our **Technical Service**, with a view to solving the problem in the shortest time possible.

2.2 Definition of safety-related terms

In this manual, the following terms will be employed as to safety:

Dangerous area	each area within and/or close to the machine, where the presence of an exposed person constitutes a risk for the safety and health of this person.
Exposed person	anybody standing, either partially or totally, in a dangerous area.
Operator	person in charge of the installation, operation, adjustment, maintenance, cleaning, repair, transport of parts of the machine and all the other activities required for its operation.
Safety component	component specifically designed by the manufacturer and sold separately from the machine, aimed at ensuring safety. Consequently, the device whose failed operation jeopardizes the safety of exposed persons will be considered as a safety component.

2.3 Correct use of the machine

The machine was designed and manufactured to cut and bevel (45° jolly) single- and double-fired ceramic tiles, porcelain gres, marble, natural stone, Tuscan terracotta tiles, cement agglomerates.



THE MACHINE CANNOT BE USED FOR OTHER TYPES OF PRODUCTS WITHOUT PREVIOUS AUTHORIZATION BY RAIMONDI S.P.A., WHICH WILL NOT BE HELD RESPONSIBLE FOR DIRECT OR INDIRECT DAMAGE DERIVING FROM AN IMPROPER USE OF THE MACHINE

Use

The machine is semi-automatic, the blade advancement is determined by the human strength and so its advancement speed will have to be commensurate with the hardness and thickness of the material to be cut. Cutting of materials shall be made with sharp blades and water, which shall always be present in the tank, in the required quantity.



THE MACHINE CANNOT BE USED FOR DRY CUTTING AND WITH INEFFECTIVE BLADES.

2.4 Characteristics of the machine

Type of blades to be used

A series of cutting blades, suitable for the ZOE ADV machine, will ensure optimization of the activity, as well as good results.

Blade characteristics:

External diameter	360 mm / 14"
Hole diameter	25,4 mm / 1"
Direction of rotation	CLOCKWISE
Rotation speed	rpm ⁻¹ 2000 ÷ 2400

Types of allowed blades are defined below:

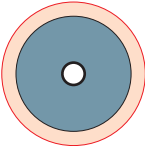
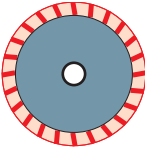
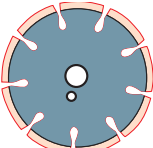
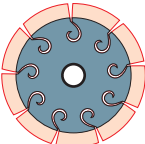
BLADE	RECOMMENDED FOR
 <p>CONTINUOUS RIM</p>	Ceramic, single-fired tiles.
 <p>TURBO CONTINUOUS RIM</p>	Ceramic, single-fired tiles
 <p>SEGMENTED</p>	Marble, terracotta tiles, natural stone, concrete
 <p>SPECIAL SEGMENTED</p>	Porcelain gres



USE OF BLADES OTHER THAN THOSE INDICATED HEREIN IS FORBIDDEN.

Technical characteristics of the different models

The ZOE ADV series includes three different models, differing in terms of cut length. The characteristics of each model are outlined below:

Model		ZOE 85 ADV	ZOE105 ADV	ZOE 130 ADV
Unladen mass (<i>transport</i>)	kg	80	84	98
	U.S. lb t	177	186	216
Mass - running (<i>driving</i>)	kg	96	101	118
	U.S. lb t	212	223	260
Mass - running (<i>stationary</i>)	kg	118	122	136
	U.S. lb t	260	269	300
Tank capacity	Lt	38	38	38
	U.S. gal	12	12	12
Maximum cutting thickness		120 mm / 4 ³ / ₄ "	120 mm / 4 ³ / ₄ "	120 mm / 4 ³ / ₄ "
Cut length		85 cm / 33 ¹ / ₂ "	105 cm / 41 ³ / ₈ "	130 cm / 51 ³ / ₁₆ "

Technical characteristics of the different motors

The ZOE ADV series includes a series of motors, which can be:

1. SINGLE-PHASE	230 V	50 Hz	2,2 kW 14A	2800 rpm	Class F motor
2. SINGLE-PHASE	230 V	60 Hz	2,2 kW 14A	3360 rpm	Class F motor
3. SINGLE-PHASE	115 V	50 Hz	1,65 kW 19A	2800 rpm	Class F motor
4. SINGLE-PHASE	115 V	60 Hz	1,65 kW 19A	3360 rpm	Class F motor

2.5 Description of machine groups

The ZOE ADV series are made up of a series of groups. These interact to ensure functions are always effective. The groups are:



1 Motor group

on which the cutting blade is positioned. Equipped with an ergonomic handle for an easier use for the operator and connection to the power supply.

2 Cooling group

It allows for the constant supply of cooling water for cutting, equipped with submersible pump, water collection tank and adjustment cock.

3 Frame

It is the load-bearing part of the machine, equipped with telescopic feet to ease transport on motor vehicle. A series of wheels, located on the side opposite the operator, allow for quick and easy movements in the working area. It is equipped with aluminum benches where the material to be cut can be leaned on.

4 Square group

It is made up of a series of millimeter instruments that determine the perpendicularity and uniformity of cuts to be made on the materials.

2.6 Position of the operator

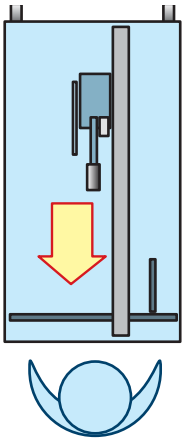

The ZOE ADV series shall be used by one single operator, who will have to stand in front of the machine and, by grabbing the ergonomic handle, will be able to make cuts in safe conditions and unstressfully.

During the working phase, the operator shall always stand in the front part and grab the handle with one hand, while the other hand holds the material to be cut over the work bench.

The material shall always be leaned against the reference square.

! CUTTING DANGER
THE MACHINE SHALL BE TURNED ON EXCLUSIVELY WHEN THE OPERATOR IS IN THE WORKING POSITION. THE MACHINE SHALL BE TURNED OFF AT THE END OF EACH CUTTING OPERATION. GETTING THE HANDS CLOSE TO THE CUTTING BLADE WHEN IT IS RUNNING IS STRICTLY FORBIDDEN.

2.7 Safety devices

The ZOE ADV series is equipped with the following safety devices:



1 **ON/OFF switch**

It allows for the start and stop of the machine. In case of potential danger, the machine shall be turned off by means of the red OFF switch.

2 **Blade guards**

The side protections of the blade prevent water and debris, produced during the cutting operation, from reaching the operator. The brushes of the guard are subject to wear and shall be replaced at regular intervals.

Another safety device is represented by the electric supply plug, which, in case of danger, will have to be immediately disconnected.

! RAIMONDI S.P.A. WILL NOT BE HELD RESPONSIBLE FOR DAMAGE CAUSED BY EJECTIONS RESULTING FROM SCARCE MAINTENANCE OF OR TAMPERING WITH THE GUARDS, OR FROM AN ERRONEOUS POSITION OF THE OPERATOR (SEE PICTURE SHOWING THE POSITION OF THE OPERATOR).

2.8 Accessories of the machine

The ZOE ADV series is supplied with the following accessories:



1. 30 mm. hexagon wrench.
2. 10 mm. socket head screw.
3. Use and maintenance manual in the relative language.

2.9 Noise

The machine was designed and manufactured in such a way as to reduce at source the machine noise level. Obviously, sound pressure varies in relation to the type of blade, its wear status and the material to be cut; hence, we have made a series of measurements using different types of blades and different materials, both indoors and outdoors.

Measurements made in the operator position on a similar machine have provided the following values, where:



The weighted continuous equivalent sound pressure level A1 [$L_{Aeq} = \text{dB(A)}$] Outdoor measurements

<i>Type of blade</i>	<i>Type of material</i>				
	Hollow	Double-firing	Porcelain	Brick	Stone
 Continuous	68,8	88,3	93,0	87,9	88,8
 Segmented	83,1	101,1	106,2	103,7	102,3
 Special segmented	71,9	89,8	96,0	92,4	94,8

Weighted continuous equivalent sound pressure level A1 [$L_{Aeq} = \text{dB(A)}$] Indoor measurements

<i>Type of blade</i>	<i>Type of material</i>				
	Hollow	Double-firing	Porcelain	Brick	Stone
 Continuous	75,5	96,7	97,5	88,7	95,8

Weighted maximum instant sound pressure level C1 [$L_{pc} = \text{dB(C)}$] Outdoor measurements

<i>Type of blade</i>	<i>Type of material</i>				
	Hollow	Double-firing	Porcelain	Brick	Stone
 Continuous	71,6	91,8	96,7	91,4	92,4
 Segmented	86,4	105,1	110,4	107,8	106,4
 Special segmented	74,8	93,4	99,8	96,1	98,6

The conditions for indoor measurements are the following:

Building size:

length	8 m
width	5 m
height	3 m

Type of premises:

floor	polished concrete
covering	tile
walls	masonry with side glass

Instrument used Bruel & Kjaer mod. 2221 class 1

Reference standard DIN 45635

The use of the machine is only allowed provided that suitable hearing protection is ensured. The employer shall hence compulsorily provide the operators with personal protection equipment (earphones, plugs).

2.10 Vibrations

The machine was designed to minimize the effects generated by vibrations. In any case, these are associated to relevant factors, such as the type of material to be cut and wear of the disc.

The results of the measurements carried out in the field, implementing UNI EN ISO 8662-12:1999, are the following:

Handle		Linear values (0 = n.a.)					
A lin x	16,0	m/sec ²					
A lin y	16,5	m/sec ²					
A lin z	12,2	m/sec ²					
A (lin) sum	26,4	m/sec ²					
		Weighted values ISO 5349/2001 (0 = n.a.)					
A lin x	1,5	m/sec ²					
A lin y	1,8	m/sec ²					
A lin z	1,3	m/sec ²					
A (lin) sum	2,7	m/sec ²					
A (8) (m/sec ²)							
1,0	1,4	1,7	1,9	2,1	2,3	2,5	2,7
1	2	3	4	5	6	7	8
Exposure time (hours)							

Formula to calculate the level of daily exposure to vibrations - A(8)

For the comparison with exposure limit values and action values, the total weighted acceleration, obtained through the vector sum of the components, shall be standardized, namely analytically referred to a reference time of 8 hours.

$$A(8) = A_{(w)sum} \sqrt{\frac{T}{T_0}}$$

where, in line with the standard adopted symbols:

- $A_{(w)sum}$ It is the total acceleration, sum of the three axial components.
- $A(8)$ It is the weighted equivalent acceleration for 8 hours.
- T It is the overall acceleration exposure time - $A_{(w)sum}$
- T_0 It is the reference time (8 hours, equal to 480 minutes or 28800 seconds)

In the overall assessment, non-continuous use caused by time fragmentation for material positioning and removal thereof once split up shall be taken into account. RAIMONDI S.p.A. believes ZOE ADV shall be included in the group of machines not exceeding the limit values provided for by the Directive 2004/44/EC.

If during the working day the operator foresees several exposures to vibrations of different origin and entity (as for the use of several vibrating equipments), the parameter A(8) will have to be calculated as weighted sum of the different contributions:

$$A(8) = \sqrt{\frac{1}{T_0} \sum_{i=1}^n A_{(w)sum,i}^2 \cdot T_i}$$

where:

- $A_{(w)sum,i}$ It is the total acceleration of the i-th operation
- T_i It is the overall acceleration exposure time - $A_{(w)sum,i}$

Consequently, in this case, the employer shall compulsorily provide the operator with the protection devices set forth in the Legislative Decree 187/05 in relation to the values of the standardized daily personal exposure level A(8).

2.11 Demolition and disposal

The manufacturer estimates a life of 15.000 hours of operation under normal conditions of use.

At the end of the life cycle, the company using the machine shall see to the demolition of the machine in compliance with the laws in force, first of all seeing to the emptying of lubricant fluids and overall cleaning of the different elements and, subsequently, separation of the parts making up the machine.

After disassembling the machine in line with the previous disassembling procedure, the different materials shall be separated in compliance with the laws of the country where the machine shall be eliminated. The machine does not contain harmful components or substances requiring particular removal procedures.



**DURING THE DISPOSAL PROCESS, COMPLIANCE WITH THE LAWS IN FORCE IN THE COUNTRY IS REQUIRED.
POLLUTANTS, SUCH AS OILS AND SOLVENTS, SHALL BE STORED EXCLUSIVELY IN METAL DRUMS.**

2.12 CE Manufacturer's declaration

DIRECTIVE 2002/95/EC (RoHS Directive) of the European Parliament and of the Council of 27 January 2003 on the restriction of the use of certain hazardous substances in electrical and electronic equipment.

DIRECTIVE 2002/96/EC (WEEE Directive) of the European Parliament and of the Council of 27 January 2003 on waste electrical and electronic equipment.

With reference to the Directives in question, and in particular to the ANNEXES "I A" and "I B" of the Directive 2002/96/CE, RAIMONDI S.p.A., declares that its product.

DOES NOT FALL IN THE FIELD OF APPLICATION OF THE DIRECTIVE 2002/95/EC

The Directive in question also provides for specific EXEMPTIONS, among which, at point 6 of the ANNEX of the Directive 2002/95/EC... 6) *Lead as an alloying element in steel containing up to 0,35 % lead by weight, aluminum containing up to 0,4 % lead by weight, and as a copper alloy containing up to 4 % lead by weight...*

The raw materials used by RAIMONDI S.p.A., for the manufacturing of its components, are comprised within such EXEMPTION limits.

All surface treatments and plastic materials, present in the RAIMONDI S.p.A. products, do not contain the forbidden substances listed in the Directive 2002/95/EC

3.1 Packing transport

Transport shall be made using a fork lift truck, inserting the forks into the specific seats of the pallet. Use a lift truck having a suitable capacity (>200 Kg).

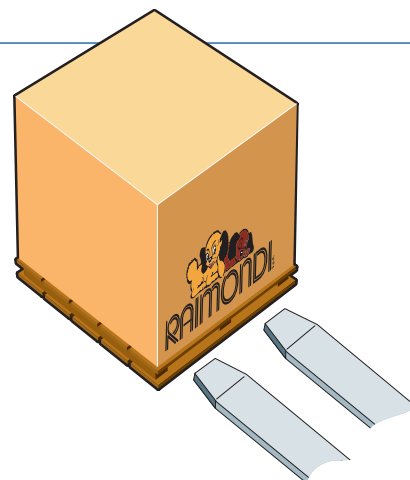

3.2 Manual handling

Manual handling

For handling use the transport handle, exploiting the lever effect, specifically provided to this end, located on the front side of the machine and on wheels in the rear side.

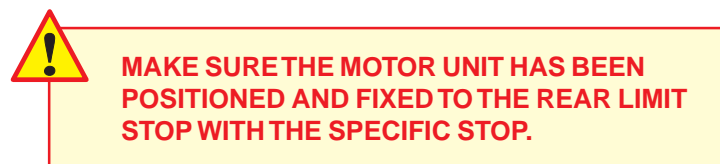

Lifting

Two persons are required to lift the machine; to do so, grab the specific handles positioned on the front and rear sides of the machine.

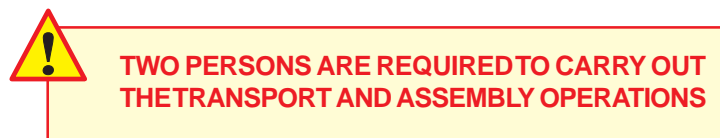
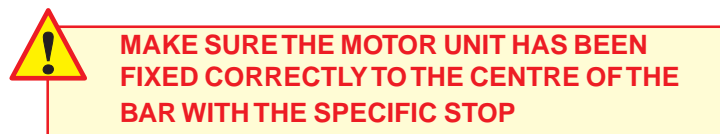

In case the machine needs to be stored during idle periods, it shall be kept in covered premises, so that the machine can be protected from bad weather, and free from aggressive chemicals .
Before storing the machine, disconnection from the mains and unloading of the cooling water tank is recommended.
The machine shall be stored in environments with adequate temperatures (from -10 to + 70°C).

3.3 Power supply

The “ZOE” saw machine shall be supplied at the voltage corresponding to the value indicated on the “TECHNICAL DATA” label.
The machine shall be connected to a line only with an effective ground cable. In case of doubt, do not connect the machine.



THE USE OF EXCESSIVELY LONG PATCH CORDS OR POWER SUPPLY WITH CURRENT GENERATORS, MIGHT LEAD TO THE FOLLOWING TROUBLES:

1. SLOW STARTING OF THE MOTOR AND SAFETY DEVICES INTERVENTION;
2. MOTOR OVERHEATING WITH POWER DROP;
3. THE SWITCHING ON-OFF DEVICE DOES NOT WORK



IF THE MACHINE IS CONNECTED TO THE MAINS BY MEANS OF A PATCH CORD, THIS SHALL HAVE THE FOLLOWING CHARACTERISTICS:

1. MAXIMUM LENGTH 10 METERS
2. HAVING A SECTION SUITABLE FOR THE LOAD
3. BEING COMPLETELY UNCOILED

Connect the machine to a 16A socket.

The “ZOE” machines shall be connected to the mains equipped with a residual current circuit breaker (RCCB) or a Class II isolation transformer, having the characteristics indicated in the table:

Transformer	230V - 50 Hz 3,2 kW	230V - 60 Hz 3,2 kW	115V - 50 Hz 2,1 kW	115V - 60 Hz 2,1 kW
RCCB	14A Id 20mA	14A Id 20mA	18A Id 20mA	18A Id 20mA



FOR THE CORRECT USE OF THE RESIDUAL CURRENT CIRCUIT BREAKERS, DO NOT FORGET TO CHECK THEIR EFFICIENCY BY MEANS OF THE TEST BUTTON PLACED ON THE FRONT PART OF THE DEVICE ITSELF.

3.4 Assembly of the machine

! TO CARRY OUT THIS OPERATION, WEAR THE PROTECTIVE GLOVES AND ACCIDENT-PREVENTION SHOES

Remove the machine from the pallet and make sure there are no broken or damaged parts.

! MAKE SURE THE MOTOR GROUP HAS BEEN FIXED CORRECTLY



Free the rear leg by completely unscrewing the leg fixing handles (A). Go to the rear side of the machine and, by means of the handle (B), lift the machine until the leg has completely come out of the frame. Turn the leg by 180° so that the wheels are turned outwards and put it back into the frame. Two persons are required to carry out this operation.

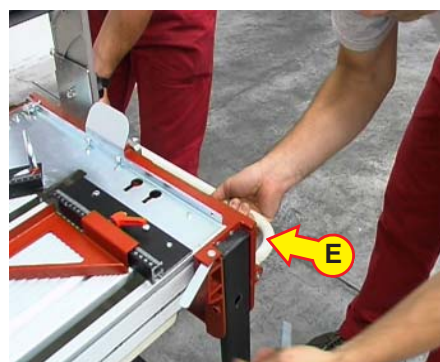
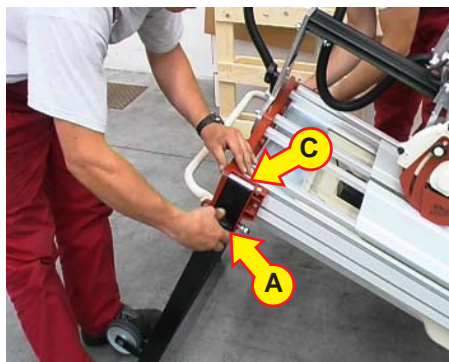

Slowly lower the machine until the leg is resting on the safety bar (C) previously closed and firmly screw the leg fixing knobs (A). Go to the front side of the machine and completely unscrew the leg fixing knobs (D).

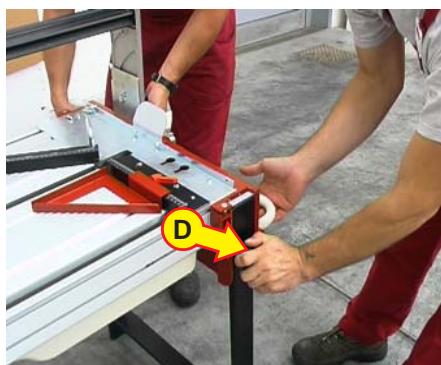
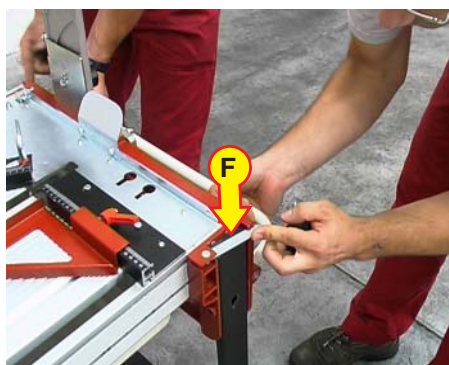

Grip the handle (E) and lift the machine until the two safety bars (F) can be inserted. Lower the machine until the leg touches the safety bars (F). Firmly screw the leg fixing handles (D).

3.4.1 Tank filling



TO CARRY OUT THIS OPERATION, MAKE SURE THE MACHINE IS NOT CONNECTED TO THE MAINS.

After closing the drain hole with the specific plug, pour cold and clean water into the tank until a level 2cm above the recycle pump has been reached.

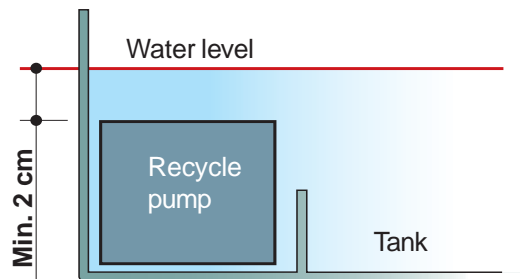

4.1 Preliminary operations before cutting

The machine is equipped with a device, located next to the blade, defined as pressing device (A).



THE MAXIMUM CUT THICKNESS USING THIS DEVICE IS 20 mm.



BEFORE POSITIONING FOR THE 45° JOLLY CUT, REMOVE THE PRESSING DEVICE.

4.1.1 Diamond blade external protection

The external protection (B) shall be positioned in relation to the thickness of the material to be cut.



THE DISTANCE FROM THE WORK BENCH SHALL NOT BE LESS THAN 35 mm.



4.2 Cutting

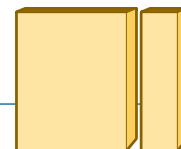

BEFORE CUTTING, MAKE SURE THE UPRIGHT LOCKING HANDLE (A) AND LIFT LOCKING KNOB (B) HAVE BEEN SCREWED TO THE END OF TRAVEL AND THAT CUTTING LINE / SQUARE ALIGNMENT IS COMPRISED WITHIN THE TOLERANCE RANGE $\pm 1,5$ MM PER METER

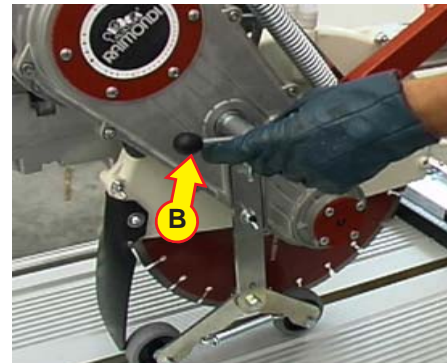

During cutting, advance speed shall be proportionate to the hardness and thickness of the material to be cut, in order to avoid flexure or distortion of the blade and motor overload.



IN CASE OF CUTTING OF THICK MATERIALS, IT IS ADVISABLE THAT CUTTING IS MADE IN SEVERAL PASSES ACCORDING TO THE HARDNESS OF THE MATERIAL

Push the starting switch, wait until cooling water of the diamond blade has come out. Start cutting slowly approaching the diamond blade to the material to be cut. Go on cutting keeping a constant advancement speed, slowing down when close to the end of cutting.

In case of breaking of the end part of the tile (last centimeter) sharpen the diamond blade making some cuts with the dressing stone.

If the problem is not solved, comply with the following:

make a cut of about 2 cm on one side of the tile, turn it and make the cut until you reach the 2 cm cut previously made.

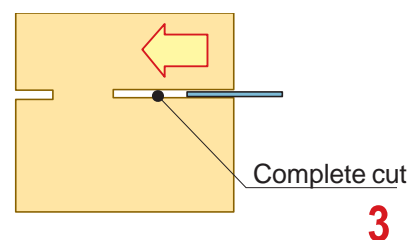
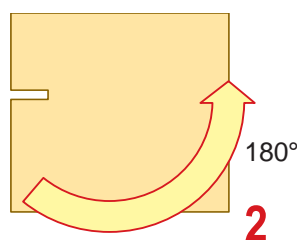
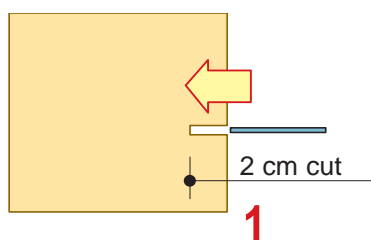

DURING THE CUTTING OPERATION, COMPLY WITH THE INSTRUCTIONS IN THE "OPERATOR POSITION" PARAGRAPH

VERIFY CLEAN WATER IS IN THE TANK, IN A QUANTITY SUCH THAT THE PUMP IS COMPLETELY SUBMERGED - SEE PARAGRAPH "5.5 TANK CLEANING". TURBID WATER CAN CAUSE MALFUNCTIONING OR BREAKING OF THE PUMP

ACT ON THE SPECIFIC COCK (C) TO SET THE CORRECT WATER FLOW ON THE BLADE.



The maximum length of the cut can be obtained as follows:

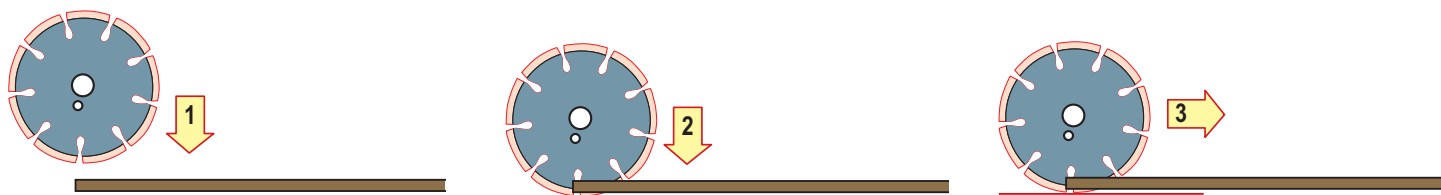

1. Bring the motor group to the beginning of the cut and at the maximum rise position.
2. Get into the material from above, like when using a cutting-off machine
3. When the low position has been reached, advance with the blade to make a complete cut.

		Cut	Cutting-off machine cut
ZOE 130 ADV	tiles size	0-115	115-130
ZOE 105 ADV	tiles size	0-90	90-105
ZOE 85 ADV	tiles size	0-70	70-85

Comply with the following:



release the motor group by slackening the handle (E), so that the blade is in the position of maximum rise, and bring it to the beginning of the cut. Place the piece to be cut on the work bench, push the starting switch, wait for the cooling water to reach the cutting blade. Slowly lower the motor group by means of the handle (F) so that the blade gets into the material, block the motor group tightening the handle (E). Advance with the blade to complete the cutting operation.

4.3 Diagonal cuts

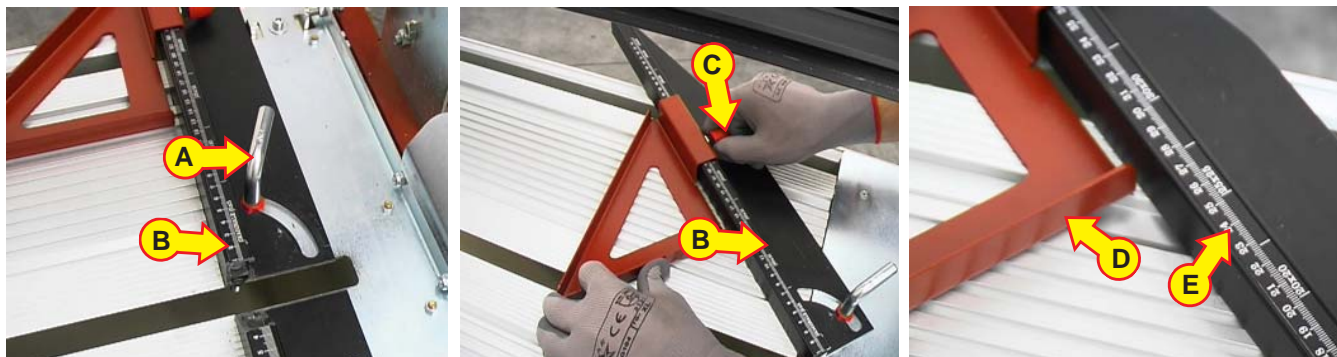
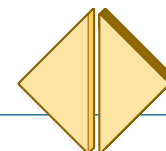

Slacken the lever (A) and position the square (B) at 45°, tighten the lever (A).
 Slacken the lever (C) and position the triangle (D) as indicated by the mark on the millimeter bar (diagonal) placed on the square (E).
 While keeping the blade above the surface of the tile, let the motor group slide and perfect, varying the inclination of the square (B), the position thereof so that the blade at the beginning and at the end of the cut matches the vertexes of the tile. Once this has been achieved, tighten the lever (A) completely, place the triangle (D) close to the edge of the tile and tighten the lever (C) completely.



**IN CASE OF CUTS WITH INCLINATIONS OTHER THAN 90° AND 45°, THE CUTTING LINE SHALL BE DRAWN ON THE TILE.
 WITH MOTOR TURNED OFF, PLACE THE TILE ONTO THE MACHINE BENCH, LET THE BLADE SLIDE OVER THE TILE, MAKING SURE THE CUTTING LINE MATCHES THE LINE PREVIOUSLY DRAWN ON THE TILE.
 APPROACH THE TRIANGLE (D) TO THE TILE EDGE AND BLOCK IT BY TIGHTENING THE LEVER (C).**

4.4 45° jolly cuts

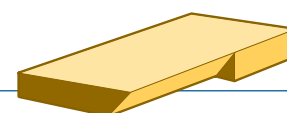

BRING THE MOTOR GROUP TO MAXIMUM HEIGHT POSITION.

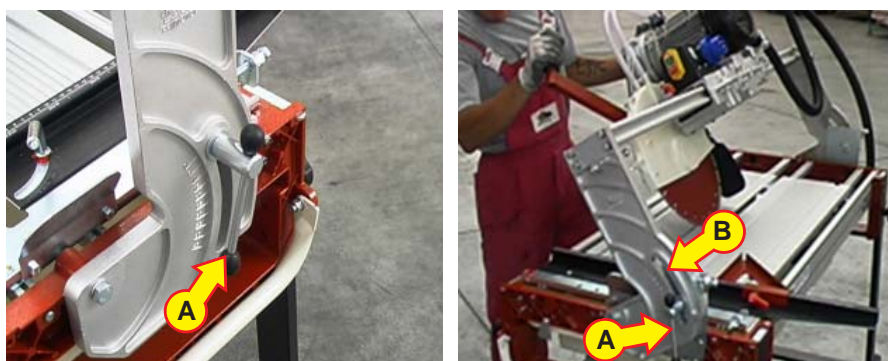

Slacken the uprights locking handles (A) (front and rear), tilt the sliding bar (B) to the end of travel and block it by firmly screwing the uprights locking handles (A).

! BEFORE POSITIONING FOR THE 45° JOLLY CUT, REMOVE THE PRESSING DEVICE (B) AND PLACE THE BLADE PROTECTION.

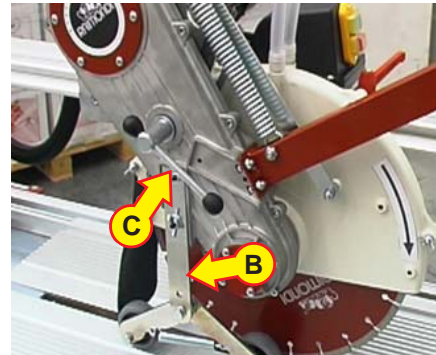
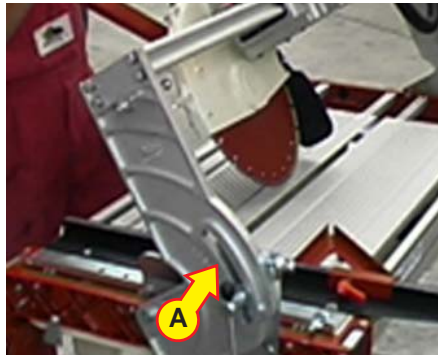

Lower the motor head (D) so that the diamond blade rim is at the same height of the work bench and block it by tightening the handle (C) completely.

! BEFORE MAKING CUTS, MAKE SURE THE UPRIGHT LOCKING KNOBS (A) AND MOTOR LIFT LOCKING KNOBS (C) HAVE BEEN SCREWED COMPLETELY.

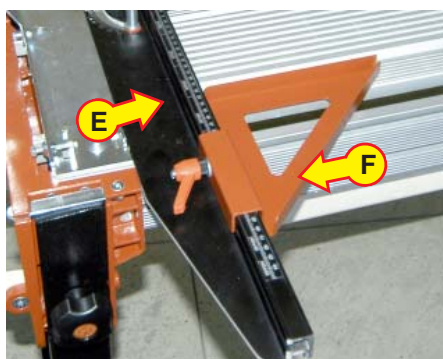

Place the tile to be beveled with glaze side turned upwards on the work bench, making sure it is perfectly resting on the square (E). Visually check the diamond blade is at the level of the glaze. Approach the triangle (F) to the tile and block it by means of the lever.

Make a 2/3 cm test jolly cut to verify it is at glaze level, if needed, after slackening the blocking lever of the triangle (F) perfect the positioning of the tile. Once the desired positioning has been achieved, approach the triangle (F) and block it by tightening the lever.

To carry out the jolly cut correctly, the blade shall be properly sharpened as a blade insufficiently sharpened would bend, not allowing to keep the cutting line at the same height of the glaze. In case of breaking of the end part of the tile, sharpen the blade making some cuts with the dressing stone.



! FOR 45° JOLLY CUTS, USE EXCLUSIVELY CONTINUOUS RIM OR SEGMENTED DIAMOND BLADES



If the problem continues, comply with the following:
make a 2cm jolly cut (1) on the orthogonal side to the side to be "jolly cut". Turn the tile by 90° (2).
Make the jolly on the desired side (3).

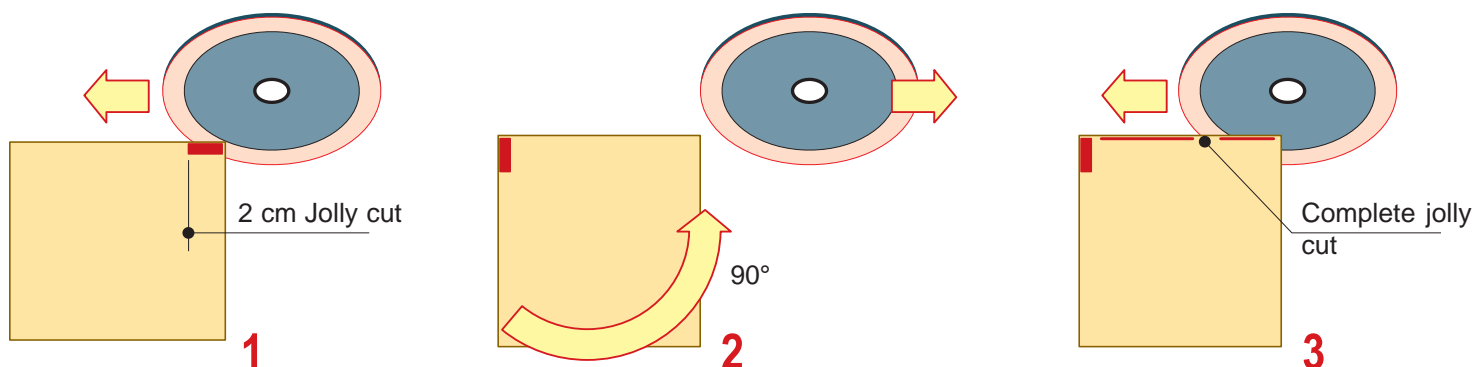

4.5 Diamond blade sharpening

When you notice that during cutting the blade "sparks", that at the end of cutting it "breaks" the tile and that advancement requires too much of an effort, the blade shall be dressed making repeated cuts on the dressing stone supplied.



4.6 Square adjustment



FOR THIS OPERATION, MAKE SURE THE MACHINE IS NOT CONNECTED TO THE MAINS.



MAKE SURE THE SQUARE (A) IS CLEAN AND IN CONTACT WITH THE STOP (B) AND THAT THE LEVER (C) IS BLOCKED

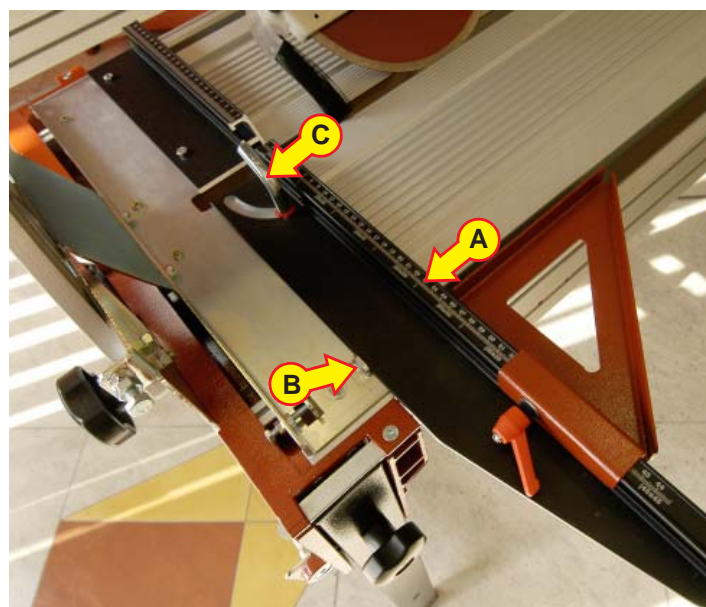

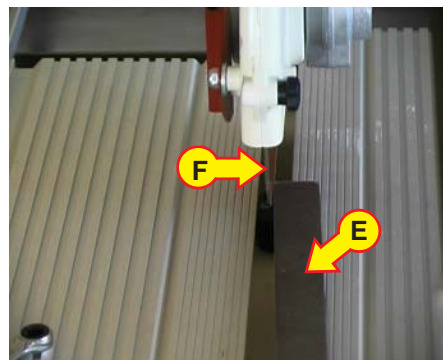
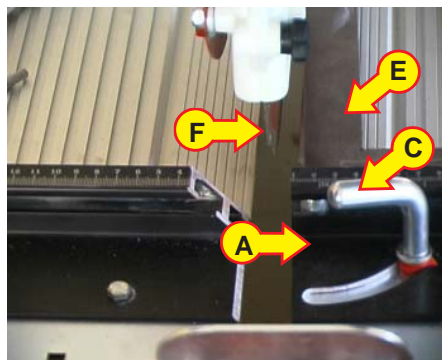

Bring the motor group to end of cutting position, lean the check square (E) against the swiveling square (A). Position the check square until it grazes the blade (F), have the motor group slide and verify whether the blade follows the square (E).

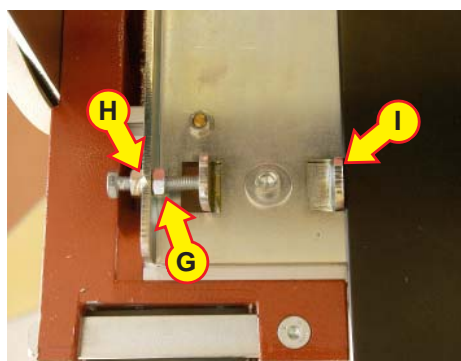
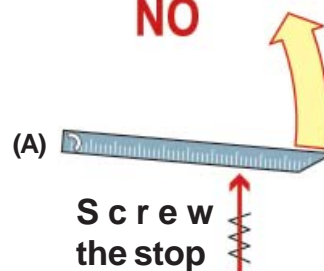
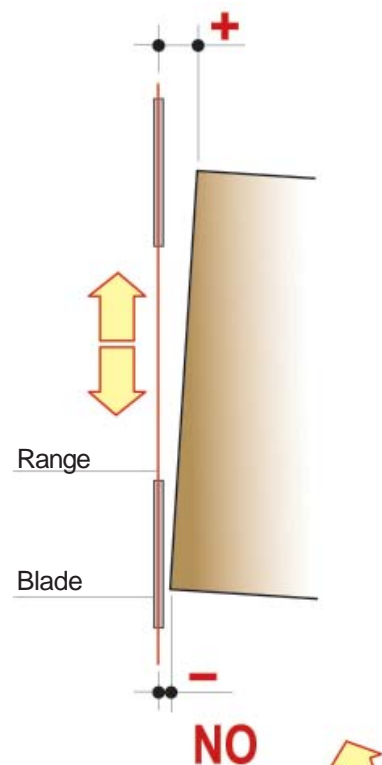
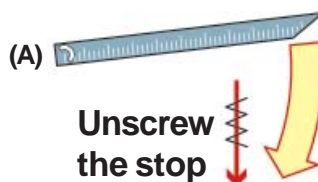
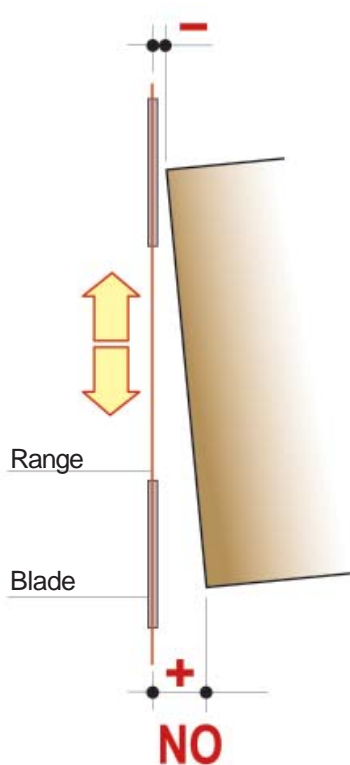
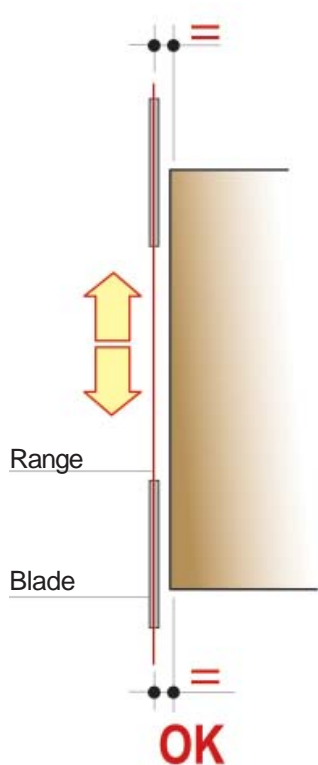

To adjust the square, comply with the following:
 Slacken the bolt (G) and the lever (C), adjust the square by means of the adjusting screw (H), hit the square (A) against the adjustment bracket (I) with the help of a tile or the check square.

4.6.1 Support alignment

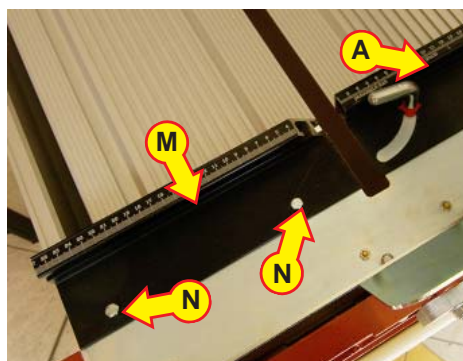

Slacken the fixing screws (**N**) of the support (**M**), lean a rule or a tile against the swiveling square (**A**) previously adjusted. Make the support (**M**) adhere to the rule or tile and tighten the fixing screws (**N**) completely.

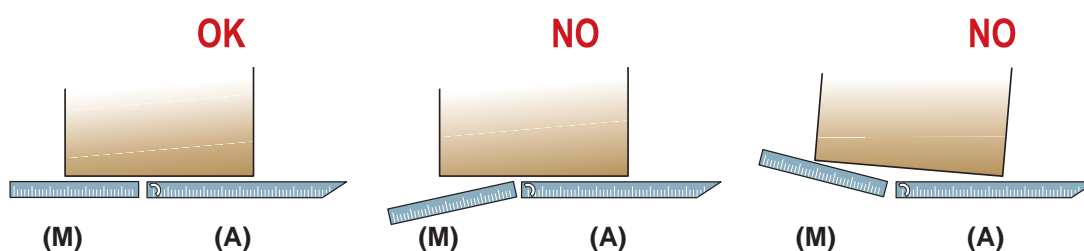

! A DEVIATION OF $\pm 1,5$ MM PER METER IS FALLS WITHIN THE MACHINE TOLERANCE RANGE

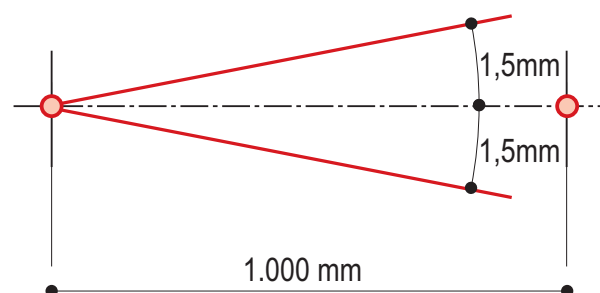

4.7 Sliding device adjustment

In case excessive backlash of the motor group is detected, comply with the following:

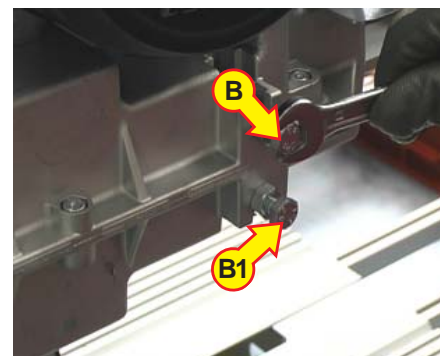
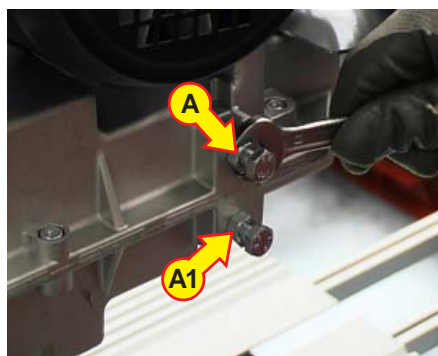
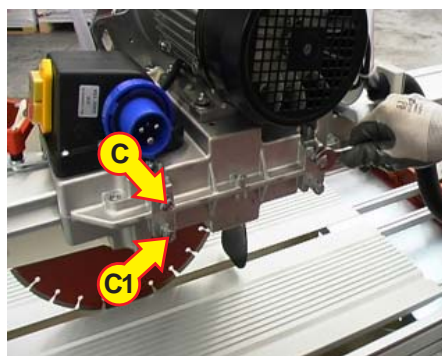

Slacken the 4 stop nuts (**A-A1**) with the 13 mm hexagon wrench. Eliminate the backlash by screwing the screws (**B-B1**). Attention: the screws (**B-B1**) shall be tightened with equal pressure. Repeat the same operation on the screws (**C-C1**). Once backlash has been eliminated, screw again the 4 stop nuts (**A-A1**). Have the motor unit slide to check the correct adjustment.

5.1 Blade replacement



FOR THIS OPERATION, WEAR PROTECTIVE GLOVES



FOR THIS OPERATION, MAKE SURE THE MACHINE IS NOT CONNECTED TO THE MAINS.

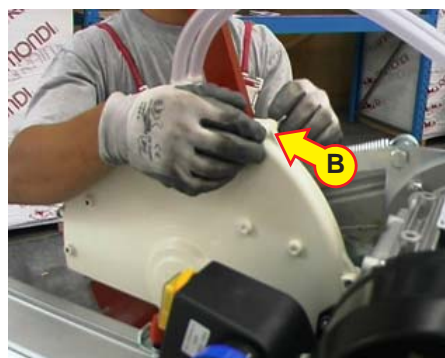

To replace the blade, first unscrew the wing nut (A); then bring the blade to maximum height position and remove the blade protection (B) unscrewing the remaining wing nuts. Insert the 10 mm socket head screw (E) into the specific housing, with the 30 mm hexagon wrench, unscrew counter-clockwise the blade locking nut (C).

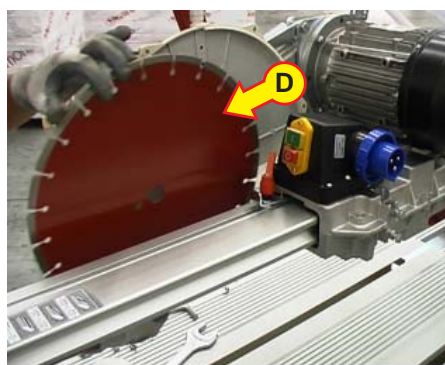
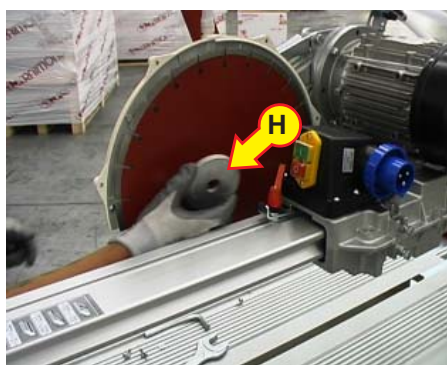

Remove the blade flange (H), extract the worn blade (D), assemble the new blade, matching the arrows indicating the direction of rotation engraved on the blade and on the blade cover. Reassemble the blade retaining flange (H). Insert the 10 mm socket head screw (E) into the seat located on the flange shaft, with the 30 mm hexagonal wrench, screw the blade stop nut clockwise. Manually turn the blade to check its correct assembly. The blade shall turn without frictions or rubbing.

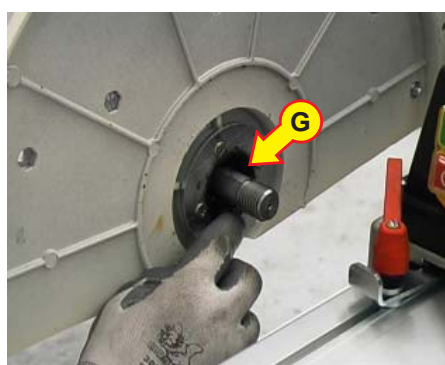

DANGER

IF THE BLADE CENTERING HOLE INCLUDES AN ADAPTER RING, UPON INSERTION INTO THE BLADE FLANGE, MAKE SURE IT STAYS IN THE CORRECT POSITION.

For a correct operation and long life of the blade shaft, once the blade has been disassembled, it is advisable to extract the blade flange (F) and grease the bearing (G).

5.2 Recycle pump replacement



FOR THIS OPERATION, MAKE SURE THE MACHINE IS NOT CONNECTED TO THE MAINS AND THE TANK IS EMPTY.

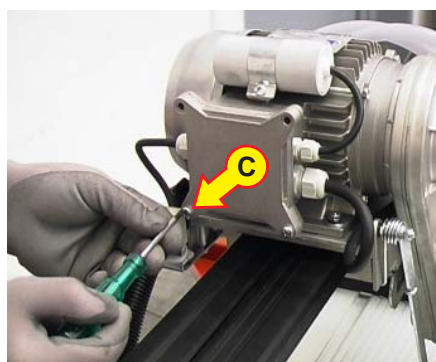
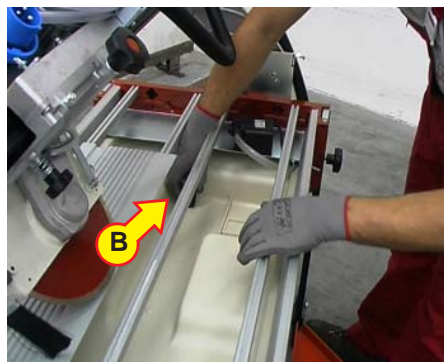

Remove the work bench (A), place a bucket underneath the tank, close to the drain hole. Remove the plug (B) to unload all the water from the tank. Open the cover of the terminal board box, located on the electric motor, by means of the screws (C).

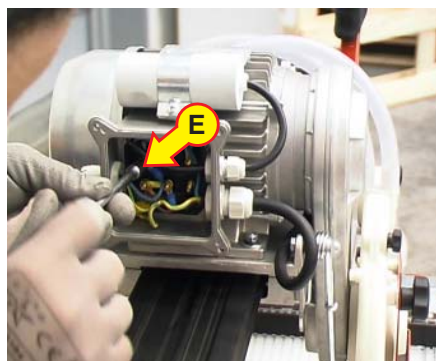
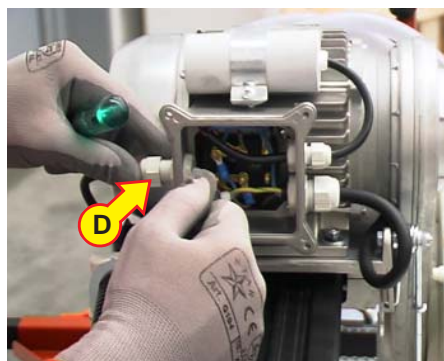

Unscrew the cable gland (D), cut the bands within the terminal board box and disconnect the pump power supply cables (E), disconnect the relative ground cable (F).

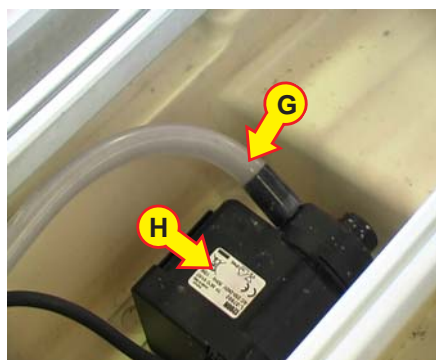
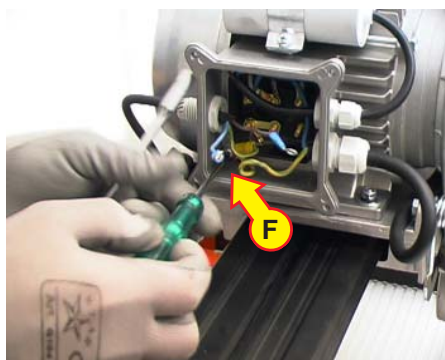

Disconnect the water delivery hoses (G), replace the damaged pump (H) with the new pump and restore the electric connections. Close the terminal board box, paying attention not to crush the conductors. Reconnect the water delivery hose (G).



AFTER THE REPLACEMENT, MAKE SURE THE CONNECTIONS HAVE BEEN MADE CORRECTLY

5.3 Starter replacement



FOR THIS OPERATION, MAKE SURE THE MACHINE IS NOT CONNECTED TO THE MAINS AND THE TANK IS EMPTY.

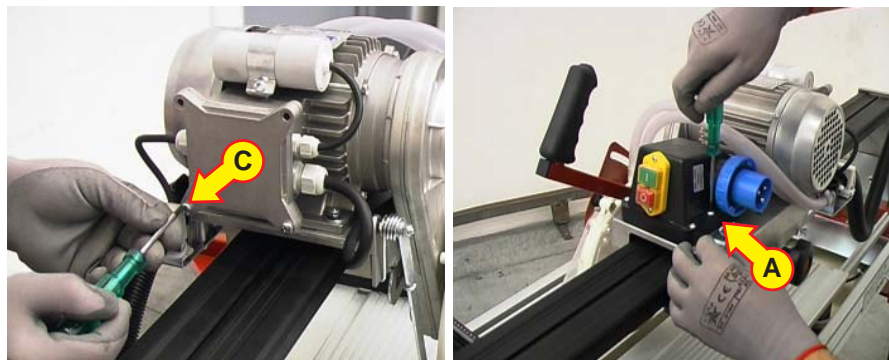

Open the terminal board cover of the electric motor (see paragraph “recycle pump replacement”), disconnect the cable coming from the starter.

Unscrew the starter screws (A) and replace it, tighten the previously removed screws. Restore the connections to the motor. Close the terminal board cover paying attention not to crush the cables and position the rubber seal gasket correctly.



AFTER THE REPLACEMENT, MAKE SURE THE CONNECTIONS HAVE BEEN MADE CORRECTLY

5.4 Starting device replacement



FOR THIS OPERATION, MAKE SURE THE MACHINE IS NOT CONNECTED TO THE MAINS AND THE TANK IS EMPTY.

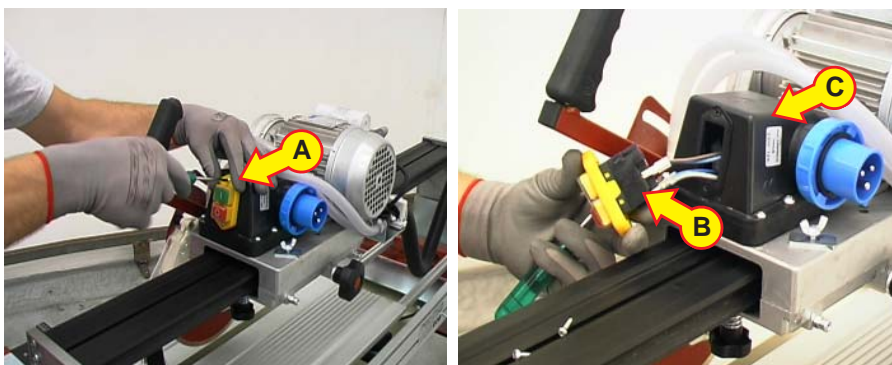

Remove the starting device unscrewing the fixing screws (A). Disconnect the electric cables and replace the on/off switch or the damaged thermal relay (B). Reconnect the cables and tighten with the previously removed screws. Make sure the seal gasket (C) is not damaged. Replace it if needed.



AFTER THE REPLACEMENT, MAKE SURE THE CONNECTIONS IN THE TERMINAL BOARD HAVE BEEN MADE CORRECTLY, VERIFYING THE BLADE ROTATION DIRECTION

5.5 Tank emptying and cleaning



FOR THIS OPERATION, MAKE SURE THE MACHINE IS NOT CONNECTED TO THE MAINS.



Place a bucket underneath the tank, close to the drain hole. Remove the plug (A) and let dirty water outflow. Remove the pump (B) from the tank.



DISPOSAL OF WATER CONTAINED WITHIN THE TANK SHALL BE MADE IN COMPLIANCE WITH THE LAWS IN FORCE IN THE COUNTRY OF USE.

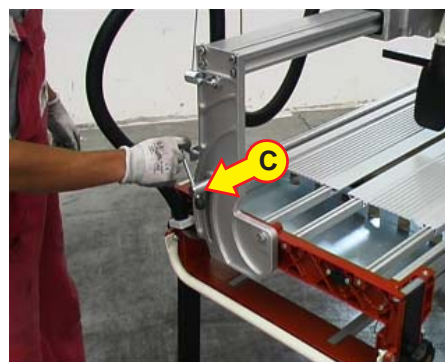

BEFORE TILTING THE SLIDING BAR:

- 1) REMOVE THE PRESSING DEVICE;
- 2) MAKE SURE THE DIAMOND BLADE DOES NOT CLASH AGAINST THE MACHINE FRAME

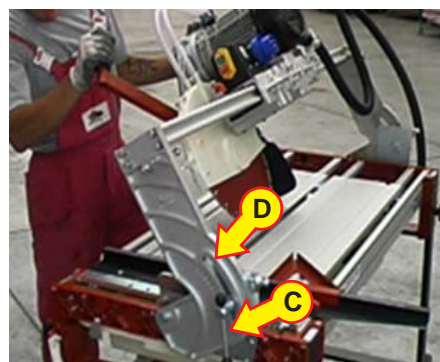

To extract the tank, the sliding bar shall be positioned at 45°. Bring the motor group to maximum height position. Slacken the uprights locking handles (C) (front and rear), tilt the sliding bar (D) to the end of travel and block it by screwing the uprights locking handles (C) completely.

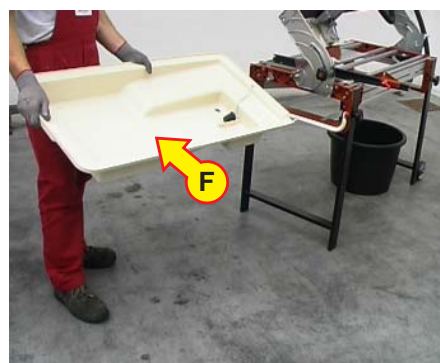
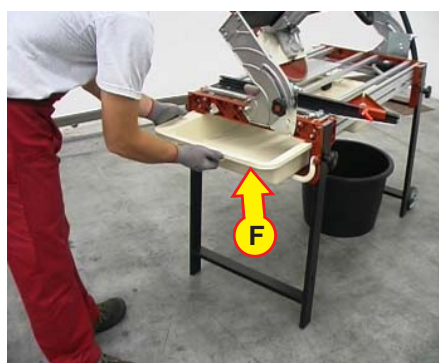
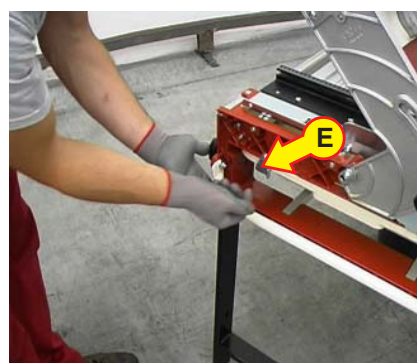

Turn the tank stop (E) counterclockwise, extract the tank (F) and clean it thoroughly.

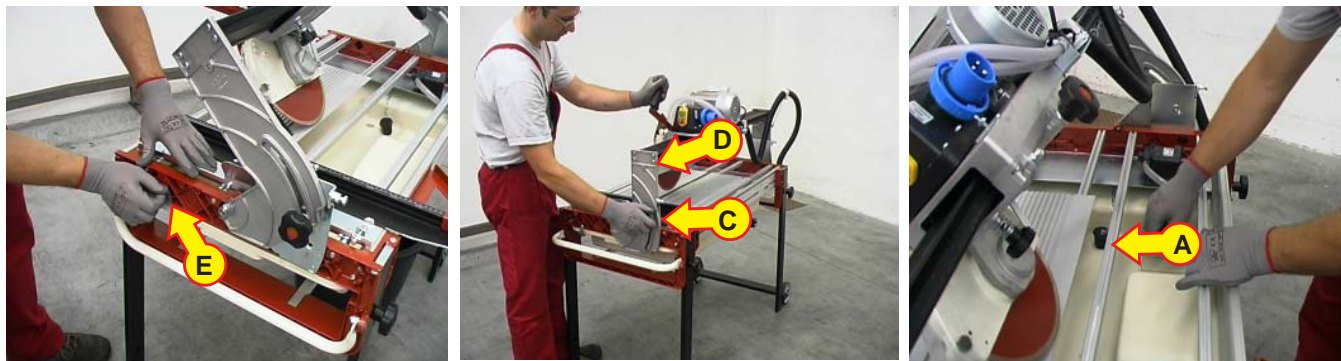

Insert the clean tank (F), turn the tank stop (E) clockwise, to prevent its movement.
Slacken the uprights locking handles (C) (front and rear), bring the sliding bar (D) back to vertical position to the end of travel and block it, screwing the uprights locking handles (C) completely.



Put the plug (A) and the recycle pump (B) back in place.



FOR A CORRECT OPERATION OF THE PUMP, WATER SHALL BE KEPT CLEAN
UPON EACH TANK WATER CHANGE, CLEAN THE FILTER AND THE PUMP ROTOR.

6.1 OPTIONAL ACCESSORIES

6.2 Tile stopping device

The tile stopping device prevents movements of the tile during cutting. It is particularly useful in case of cutting of large-sized tiles.

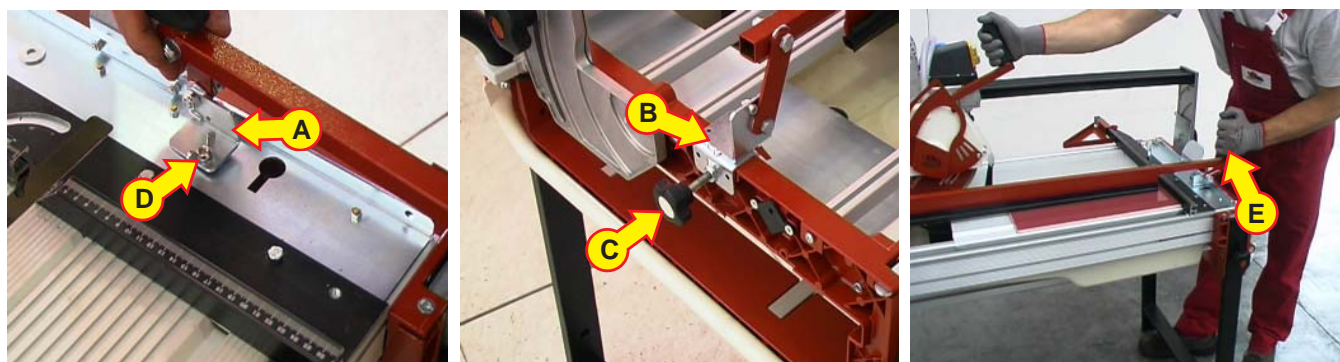

Insert the oval head screw located on the bracket (A) into the specific slot. On the other side of the machine, insert the clamp bracket (B) onto the tank head. After verifying that the tile stopping device is parallel to the cutting line, tighten the handle (C) and the wing nut (D) completely. Once the tile has been positioned on the machine bench, by acting on the handle (E), the tile is blocked.

6.3 Extension benches

The extension benches that can be applied to the sides of the tank to increase the size of the machine bench.

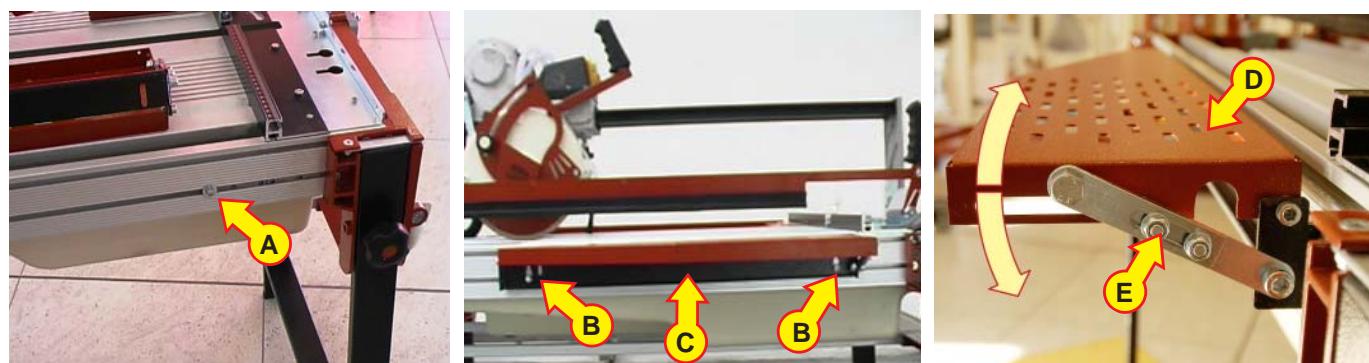

Slacken the screws (A) until the bracket (C) can be fitted on the screws (A) through the slots (B). Once insertion has been completed, lift the extension bench (D) and push the bracket (C) upwards. After checking the extension benches are at least 2 cm from the swiveling square, screw the screws (A) completely. In case the extension bench is not at the same level of the machine bench, it can be adjusted after slackening the nuts (E).

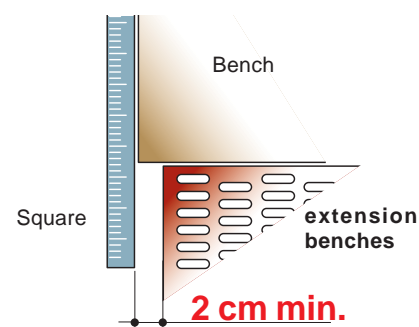

6.4 Set-square

In case of repeated cuts or jolly on large-sized tiles, the set-square ensures constant cuts or jollies of the preset size.

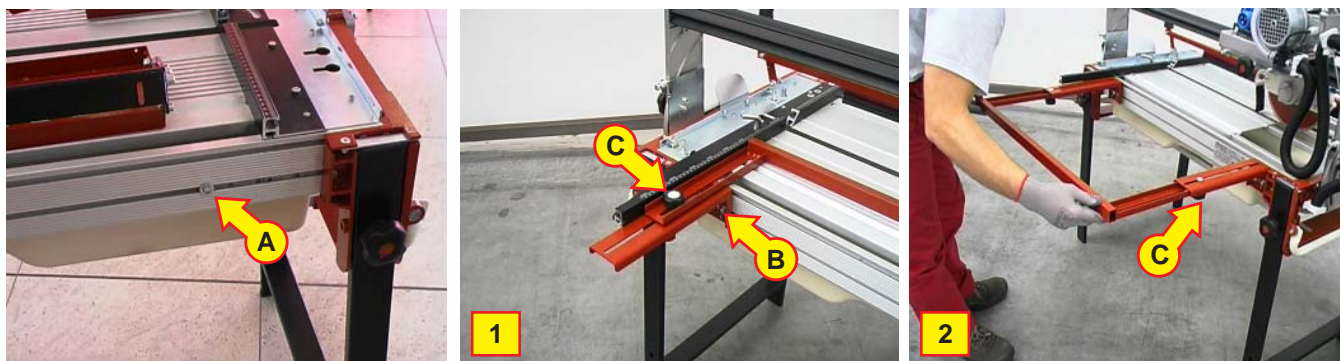

The set-square shall be fixed to the side profiles of the tank by means of the brackets (A).

Remove the screws on the brackets (A). Slacken the handles (C). Fix the set-square onto the brackets (A) by means of the wing nuts (B).

Picture 1 For cuts / jolly from 0 to 50cm

Picture 2 For cuts / jolly from 50 to 80cm

6.5 Rolling side table

To ease the positioning of big-sized and thick materials.

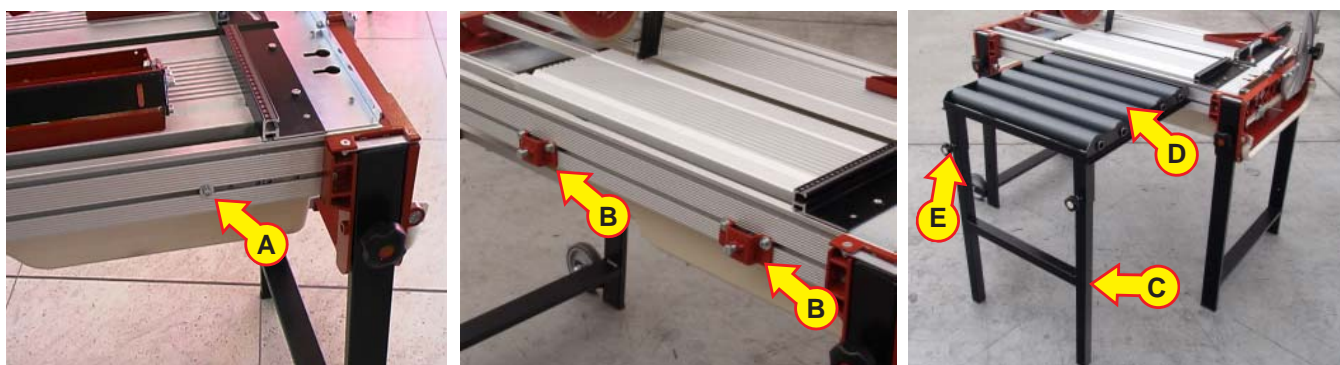

Screw the omega brackets (B) onto the brackets (A).

Insert the support leg (C) onto the rollers (D) and block it by means of the handles (E).

Insert the rollers with the support leg in the omega brackets (B) and fix it to the frame.

Slacken the handles (E) to adjust the rollers (D) height in relation to the machine bench.

7.1 Trouble-shooting

Problem	Cause	Solutions
The machine does not work	The plug is not correctly inserted in the power socket	Push the plug completely into the power socket
	Power socket undervoltage (Amp.)	Check the socket amperage
	The power supply cable is interrupted	Check the connection in the terminal board Replace the power supply cable
	Lack of voltage in the power socket	Check or provide for the check of the power socket
	The switch is damaged	Replace the switch
	The motor is interrupted	Contact the retailer or the authorized technical service centre
The blade does not turn	The belt is broken or water has got into the drive	Contact the authorized technical service centre or the retailer
	Blade assembly not correct	Check correct blocking of the disc
Drive noise	The bearings are damaged	Contact the authorized technical service centre or the retailer
The machine turns off during work	Motor excessive temperature	Wait for the motor to cool down
	Thermal-amperometric protection triggered	Search for the cause of overheating
No water to the blade	The pump is not working	Make sure the pump is free from cutting residues In case pump replacement is required, please refer to the paragraph “Water pump replacement”
	The water level in the tank is too low	Add water in the tank
	The cock is clogged	Clean or replace the cock
	The water recycle hose is bended or clogged	Disconnect the water delivery hose from the pump and blow inside it. Clean it or replace it according to the wear status.
	Holes clogged in the pump filter	Free all the holes in the filter of the rotor cover.
Excessive backlash in the motor Adjustment of the sliding device	The pulleys shall be adjusted	See paragraph “group sliding”
	The pulleys are worn	Contact the authorized technical service centre or the retailer
The blade does not cut	Blade worn	Screw the diamond rim, see paragraph “Blade sharpening”
	Blade not suitable	Assemble of suitable blade, see paragraph “Recommended blades”
Cut out of square	The square is not at 90°	See paragraph “Square adjustment”
Jolly not at glaze level	The blade bends	See paragraph “45° jolly cut”

8.1 Spare parts

ITEM	ART. CODE	DESCRIPTION
1	114RE16D	ZOE 85ADV SLIDING BAR
1	114RE16D1	ZOE 105ADV SLIDING BAR
1	114RE16D2	ZOE 130ADV SLIDING BAR
2	129DE03CDX	BLADE LOCKING NUT 20MA DX.
3	154SE12A	HANDLE WITH KNOB ZOE 85/105 ADV
3	154SE13D	HANDLE HOLDER FOR ZOE HANDLE 130 ADV
3.1	154SE14A	HANDLE WITH KNOB ZOE 130 ADV
4	156NL15D	STEEL GRID ZOE 85/105 ADV
4	156NL15D1	STEEL GRID ZOE 130 ADV
5	158GB07D	BLADE COVER LOCKING RING NUT
6	179SET360E	DIAMOND BLADE Ø 360
7	191AE07D	LEFT SUPPORT SQUARE
8	191GE02D	SQUARE HOLDER
9	192SQ04A	RIGHT TRIANGLE SQUARE
9.1	900CH8X12	8X12 M6 KEY
9.2	305MR03C	M6X15 RETRACTABLE HANDLE
10	202BP02D	LEFT UPRIGHT HOLDER
11	202BP03D	RIGHT UPRIGHT HOLDER
12	202FS05D	SQUARE ADJUSTER
13	202PR02D	COCK HOLDING BRACKET
14	235ZS 02A	110V 50/60 HZ STARTER WITH 25A THERMAL RELAY
14	235ZS 03A	230V 60HZ STARTER WITH 25A THERMAL RELAY
14	235ZS 01A	230V 50HZ STARTER WITH 15A THERMAL RELAY
14.1	320PR01C	PG11 CABLE GLAND WITH RING NUT
14.2	246PM07D	MICRO CIRCUIT-BREAKER HOLDER
14.3	264SI01C	230V CE BLUE BUILT-IN SOCKET
14.4	234MT01A	230V 50/60 HZ MICRO CIRCUIT-BREAKER WITH 15A THERMAL RELAY
14.4	234MT02A	115V 50/60 HZ MICRO CIRCUIT-BREAKER WITH 25A THERMAL RELAY
14.4	234MD03C	115V MICRO CIRCUIT-BREAKER NO THERMAL RELAY
15	240	230V 50 HZ SUBMERSIBLE PUMP
15	240110	110V 50/60 HZ SUBMERSIBLE PUMP
15	240422	230V 60 HZ SUBMERSIBLE PUMP
16	251RE01D	SLIDING BAR HOLDER UPRIGHT
17	262CP11D	PAIR OF BLADE COVER COUPLE
18	263FE05A	BLADE PROTECTION ZOE ADV

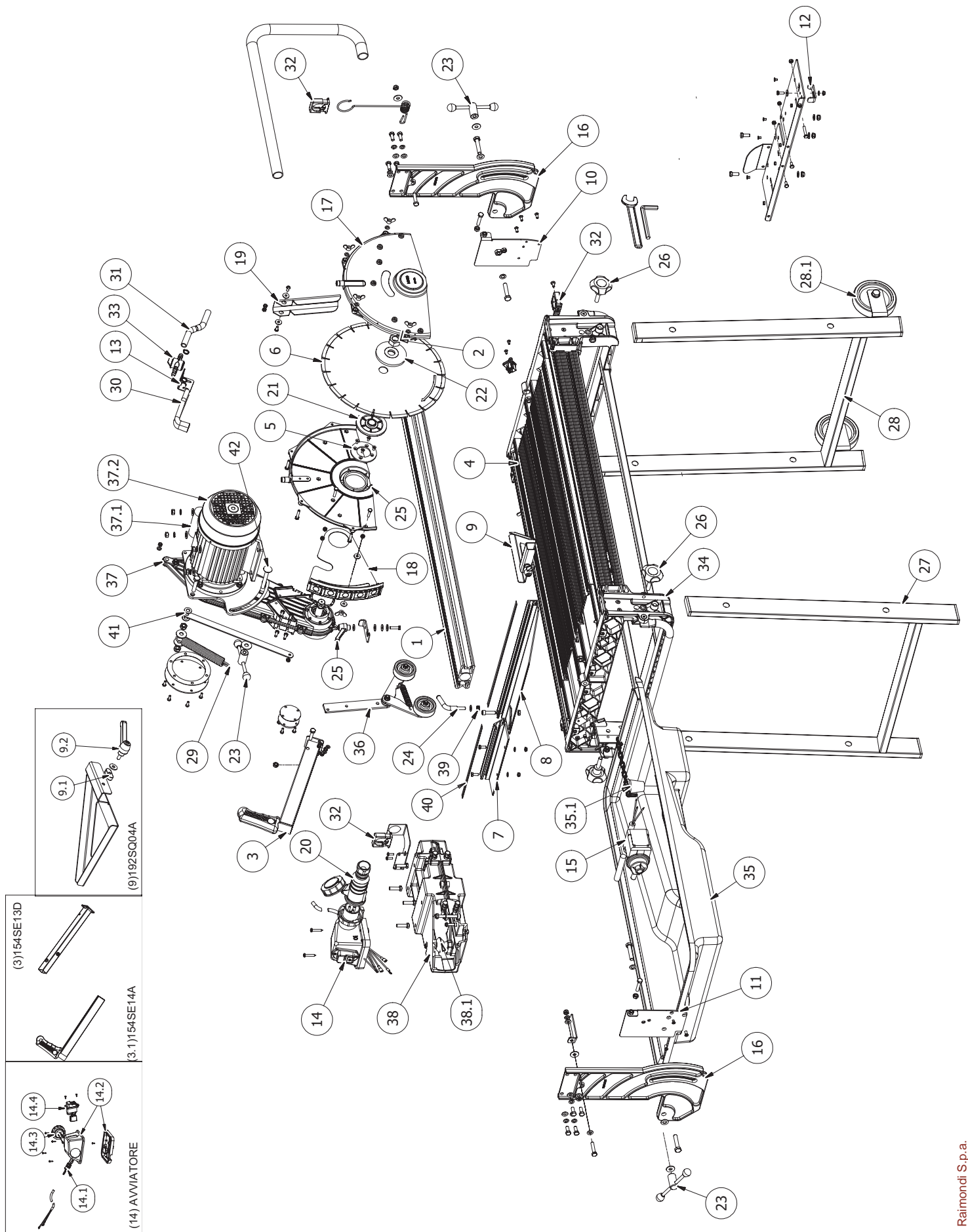

ITEM	ART. CODE	DESCRIPTION
19	263GM03D	RUBBER SPLASHGUARDS
20	264PV04C	IP67 230V SOCKET
21	278PA12D	BLADE HOLDING FLANGE
22	278PB03G	BLADE LOCKING FLANGE
23	305MA01A	FEMALE HANDLE LL45
24	305MF01D	FIXED HANDLE M8X25
25	305MR15C	RETRACTABLE HANDLE M6
26	305PM35C	KNOB M10X40
27	311GH02A	FRONT LEG
28	311GH03A	REAR LEG WITH WHEELS
28.1	315CB10C	WHEEL Ø E125X31 F15
29	314TR08D	TENSION SPRING
30	318T1107D	HOSE Ø 11X16 0,47 mt
31	318T1111D	HOSE Ø 11X16 2,40 mt ZOE 85ADV
31	318T1112D	HOSE Ø 11X16 2,60 mt ZOE 105ADV
31	318T1115D	HOSE Ø 11X16 3,10 mt ZOE 130ADV
32	320PG04C	CABLE GLAND
33	324RD01D	COCK
34	325VP01A	ZOE 85ADV FRAME TANK
34	325VP02A	ZOE 105ADV FRAME TANK
34	325VP03A	ZOE 130ADV FRAME TANK
35	326SE08A	TANK 38LT
35.1	322CN03C	TANK PLUG
36	420BLOSCO	SLIDING PRESSING DEVICE
37	420GR	MOTOR GROUP
37.1	2878001C	80MF MOTOR 115V 50/60 HZ CONDENSER
37.1	2875001C	50MF MOTOR 230V 50/60 HZ CONDENSER
37.2	297IN84D	MOTOR 2,2 230V 60HZ
37.2	297IN84D50	MOTOR 1.65 KW 110V 50HZ
37.2	297IN84D60	MOTOR 1.65 KW 110 60 HZ
37.2	297IN84D60H	MOTOR 2.2 230V 60 HZ
38	420GS01A	SLIDING UNIT
38.1	309CS01A	CONVEX PULLEY WITH BEARING
39	420LETTOR	SQUARE DEGREES INDICATOR
40	903MMPIK	MILLIMETER RULE (2PZ)
41	425LR07D	BLADE COVER CONTROL LEVER
42	900TTDE10B	SCREW UNI5732 10X80

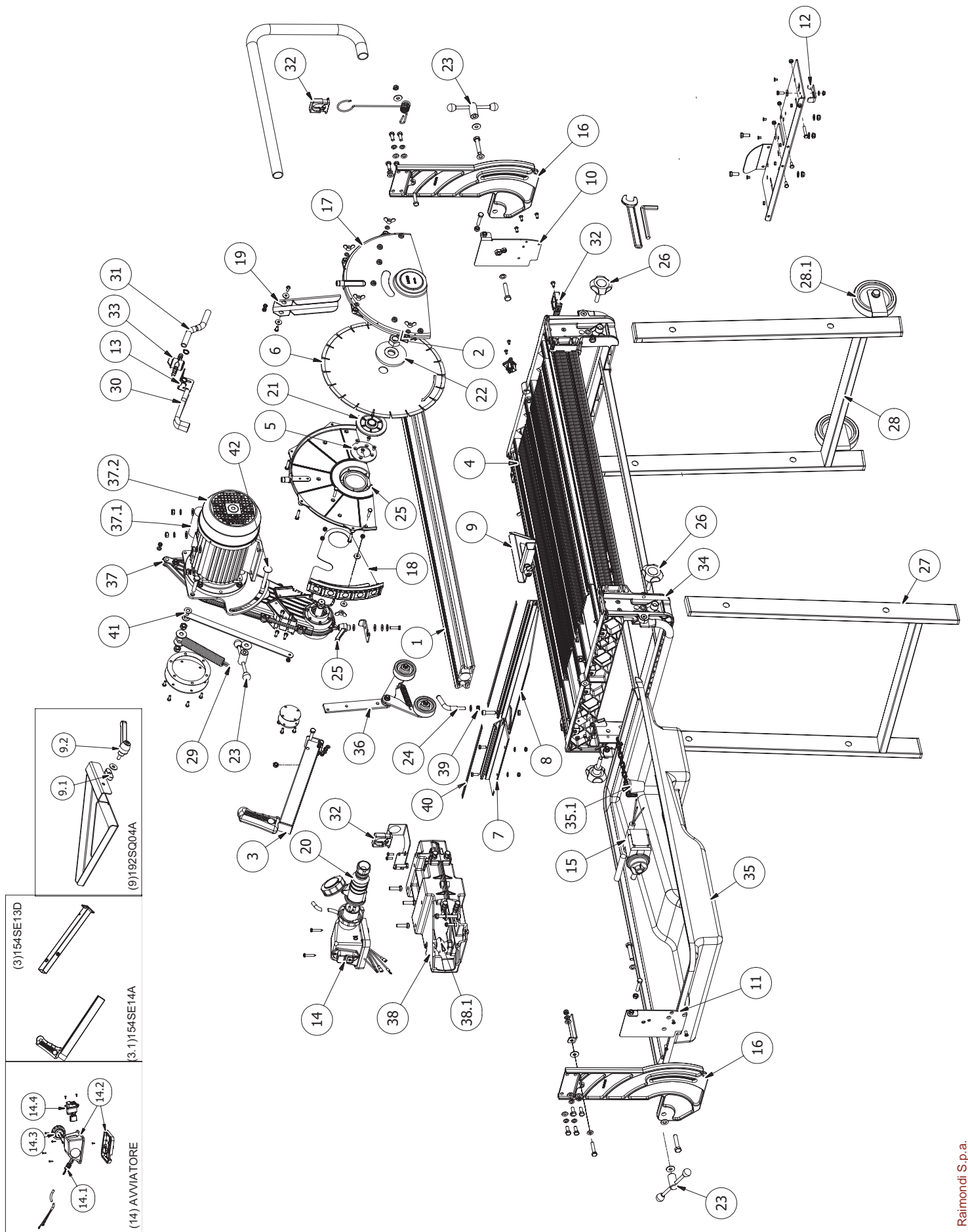

8.2 Electric diagram

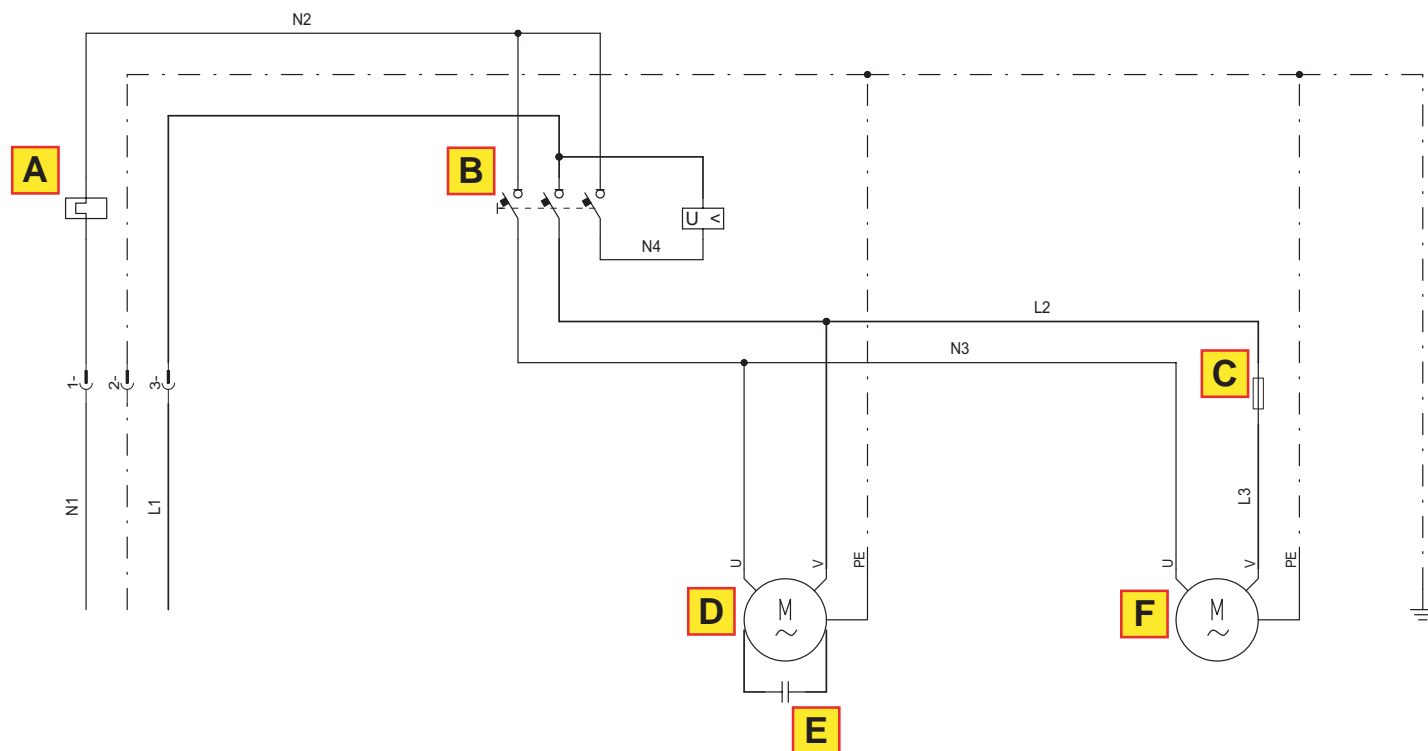

	230V - 50 Hz	230V - 60 Hz	115V - 50 Hz	115V - 60 Hz
A	3G 1,5H 07 RNF	3G 1,5H 07 RNF	3G 2,5H 07 RNF	3G 1,5H 07 RNF
B	15 A	15 A	22 A	22 A
C	F 1 A	F 1 A	F 2 A	F 2 A
D	MONOFASE 230V-50Hz 1,85 kW 9,2A 2800 min ⁻¹ class F motor	MONOFASE 230V-60Hz 1,85 kW 9,2A 3360 min ⁻¹ class F motor	MONOFASE 115V-50Hz 1,1 kW 16A 2800 min ⁻¹ class F motor	MONOFASE 115V-60Hz 1,1 kW 16A 3360 min ⁻¹ class F motor
E	230 V 50 µF	230 V 50 µF	115 V 80 µF	115 V 80 µF
F	230-50Hz 13 W 0.84 A 2800 n ⁻¹	230-60Hz 15 W 0.84 A 3360 n ⁻¹	115-50Hz 13 W 0.16 A 2800 n ⁻¹	115-60Hz 13 W 0.84 A 3360 n ⁻¹

TO BE
FRANKED



RAIMONDI
S.p.A.
MACHINES & TOOLS FOR THE TILE & STONE PROFESSIONAL

Via dei Tipografi, 11
41100 MODENA (Italy)

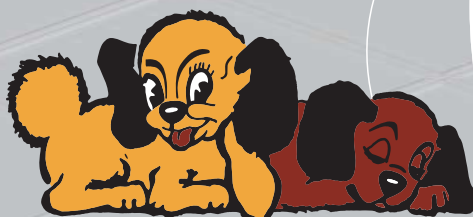

RAIMONDI
S.p.A.

MACHINES & TOOLS FOR THE TILE & STONE PROFESSIONAL

**WARRANTY
CERTIFICATE**



B WARRANTY	Model ZOE 85 / 105 / 130 ADV	Registration number <input style="width: 100%;" type="text"/>
Purchaser _____		
Address _____		
Postal code <input style="width: 20px;" type="text"/> <input style="width: 20px;" type="text"/> <input style="width: 20px;" type="text"/> <input style="width: 20px;" type="text"/>	Town _____	Province _____
Phone _____		Fax _____
Activity <input type="checkbox"/> Floor layer <input type="checkbox"/> Bricklayer <input type="checkbox"/> Building enterprise <input type="checkbox"/> Other		
Date of purchase <input style="width: 20px;" type="text"/> <input style="width: 20px;" type="text"/> <input style="width: 20px;" type="text"/> <input style="width: 20px;" type="text"/> 20 <input style="width: 20px;" type="text"/> <input style="width: 20px;" type="text"/>	Name, address and stamp of the retailer <div style="border: 1px solid black; height: 100px; width: 100%;"></div>	

Data have been entered in our lists with a view to sending information and promotional material.
 At any time, in line with art.13 of the law 675/96, you will be able to access your data, request modification or erasure thereof, or oppose their use by writing to:
 RAIMONDI S.p.A.
 Via dei Tipografi n. 11 - 41100 MODENA (Italy)

TO BE SENT ENTIRE LY FILLED IN, WITHIN 10 DAYS FROM THE DATE OF PURCHASE.



A WARRANTY TO BE SHOWN TO THE TECHNICIAN	Model ZOE 85 / 105 / 130 ADV	Registration number <input style="width: 100%;" type="text"/>
Purchaser _____		
Address _____		
Postal code <input style="width: 20px;" type="text"/> <input style="width: 20px;" type="text"/> <input style="width: 20px;" type="text"/> <input style="width: 20px;" type="text"/>	Town _____	Province _____
Date of purchase <input style="width: 20px;" type="text"/> <input style="width: 20px;" type="text"/> <input style="width: 20px;" type="text"/> <input style="width: 20px;" type="text"/> 20 <input style="width: 20px;" type="text"/> <input style="width: 20px;" type="text"/>		

Warranty clauses:

1. The machine warranty covers a 12-month period since the date of purchase.
2. The purchase date is the one indicated on the receipt for item purchased or invoice issued upon delivery of the machine by the retailer.
3. Any warranty becomes null and void if the B part is not entirely filled in and if sent later than 10 days after the date of purchase (postmark date).
4. By warranty we mean replacement or repair free of charge of components found to be defective since manufacturing.
5. Replacement of components, if made by the retailer, will be recognized free of charge once replaced components have been returned to our headquarters to be examined and declared as defective. Labor expenses are not included in the warranty.
6. All transport expenses will be charged on the purchaser.
7. The warranty does not cover parts subjected to wear, damage caused by negligence, improper use and installation and, in any case, issues not resulting from ordinary operation of the machine.
8. The warranty becomes null and void if the machine is tampered with or repaired by unauthorized personnel.
9. The warranty does not cover replacement of the machine and extension of the warranty following intervention for failure issues.
10. Nobody is entitled to modify the warranty conditions, nor to issue other warranties, in written or oral form, without the written authorization of RAIMONDI S.p.A.
11. The warranty does not cover compensation for damage, either direct or indirect, of any nature, to persons or objects, resulting from use or suspension of use of the machine.

Date of production / /

Registration number