



BPR1080
VIBRATING PAVER ROLLER
PARTS BOOK



www.BARTELLGLOBAL.com

Doc. # PB-B19038
Orig. Rel. - 03/2021
Curr Rev. - 00

TABLE OF CONTENTS

<u>PARTS LIST 1 - VIBRATING PAVER ROLLER</u>	3
FULL ASSEMBLY: BPR1080	3
FULL ASSEMBLY: BPR1080 - PARTS LIST 1	4
<u>PARTS LIST 2 - VIBRATING PAVER ROLLER</u>	7
VIBRATOR: BPR1080	7
VIBRATOR: BPR1080 - PARTS LIST 2	8

PARTS LIST 1 – VIBRATING PAVER ROLLER

FULL ASSEMBLY: BPR1080

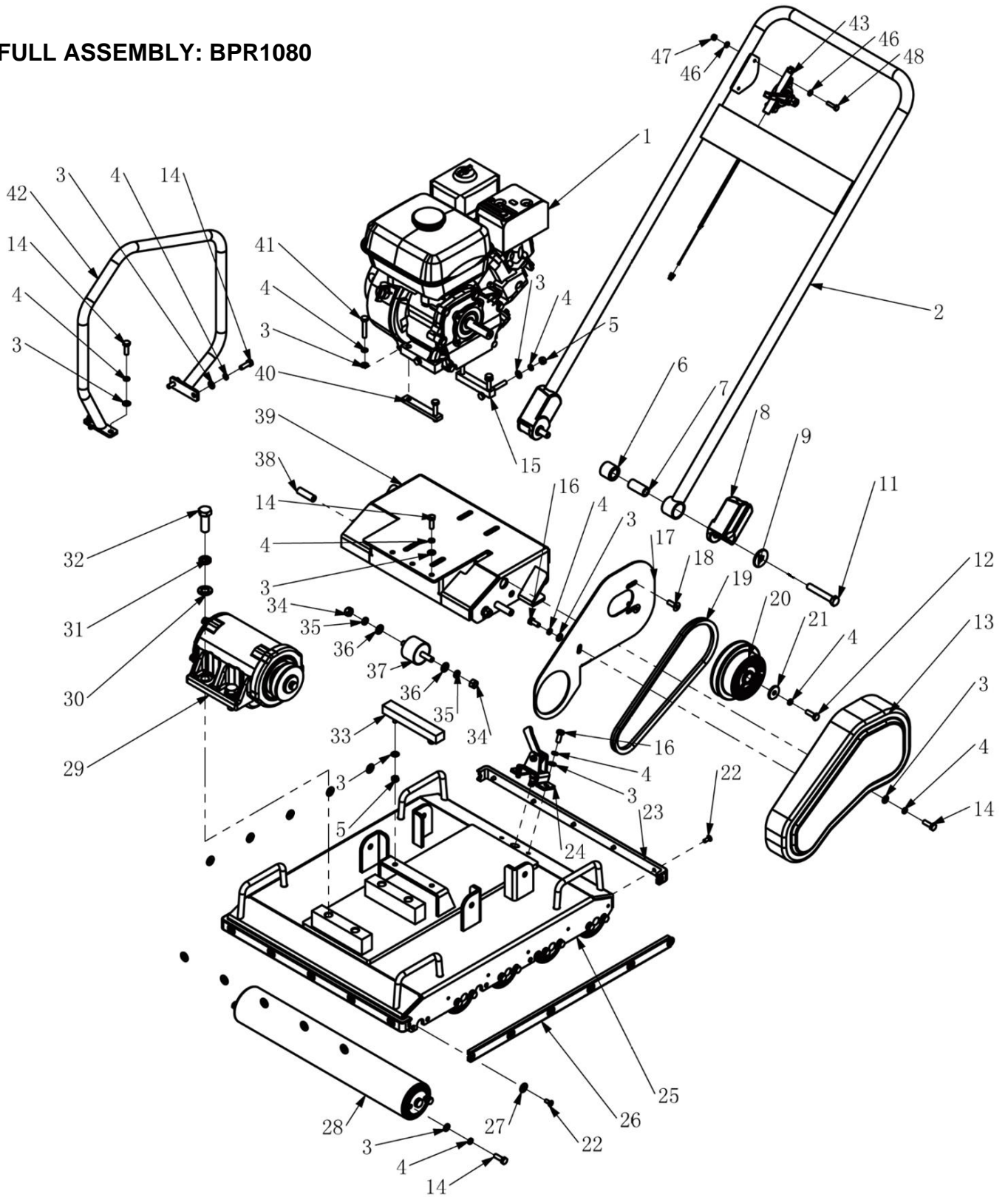

FULL ASSEMBLY: BPR1080 – PARTS LIST 1

Item #	Part #	Description	QTY	Remarks
1	-	ENGINE	1	
2	65CPC-95-28B	HANDLE	1	
3	11667	WASHER, M8	36	
4	11614	LOCKWASHER, M8	35	
5	11617	LOCKNUT, M8-1.25	3	
6	65CPC-95-30B	RUBBER COLLAR	2	
7	65CPC-95-29B	METAL COLLAR	2	
8	65CPC-95-31B	HANDLE BOOT	2	
9	14267	WASHER, M12	2	
10	10735	LOCKWASHER, M12	2	
11	22675	HHCS M12-1.75x75MM	2	
12	11256	FHSCS,5/16"-24UNFx1"	1	
13	65101237-01036	BELT COVER	1	
14	11619	HHCS M8-1.25x25MM	26	
15	65CPC-95-13B	MOUNTING BAR, W/ TENSION BOLT	1	
16	10999	HHCS M8-1.25X20MM	3	
17	65101237-01035	BACK PLATE, BELT COVER	1	
18	11256	FHSCS, 5/16"-24UNFx1"	2	
19	11896	BELT, AX30	1	
20	30202	CLUTCH ASSEMBLY	1	
21	30042	CLUTCH RETAINING WASHER	1	
22	14928	FHSCS M6-1.0x14MM	22	
23	651233	BUMPER, RUBBER, FRONT AND REAR	2	
24	651241	PARKING BRAKE	1	
25	651238	MAIN PLATE, LOWER	1	
26	651234	BUMPER, RUBBER, SIDES	2	
27	14447	WASHER, M6	22	
28	651232	ROLLER ASSEMBLY	4/5	
29	651010	EXCITER	1	
30	31211	WASHER, M16	4	
31	31260	LOCKWASHER, M16	4	
32	651078	HHCS M16-2.0x45MM	4	
33	651236	SQUARE SHOCK ABSORBER	1	
34	11802	LOCKNUT, M10-1.5	8	
35	11621	LOCKWASHER, M10	8	
36	41516	WASHER, M10	8	
37	651030	SHOCK ABSORBER	4	
38	651237	HANDLE POSITION LIMIT BAR	2	

CON'T ON NEXT PAGE

CON'T FROM PREVIOUS PAGE

39	651239	ENGINE PLATE	1	
40	65CPC-95-12B	ENGINE MOUNTING BAR	1	
41	11745	HHCS M8-1.25x55MM	4	
42	651240	PROTECTION FRAME	1	
43	65CPC-95-27B	THROTTLE LEVER ASSEMBLY	1	
46	14447	WASHER, M6	4	
47	10069	NUT, M6	2	
48	30281	HHCS M6-1.0x25MM	2	

INTENTIONALLY LEFT BLANK

PARTS LIST 2 – VIBRATING PAVER ROLLER

VIBRATOR: BPR1080

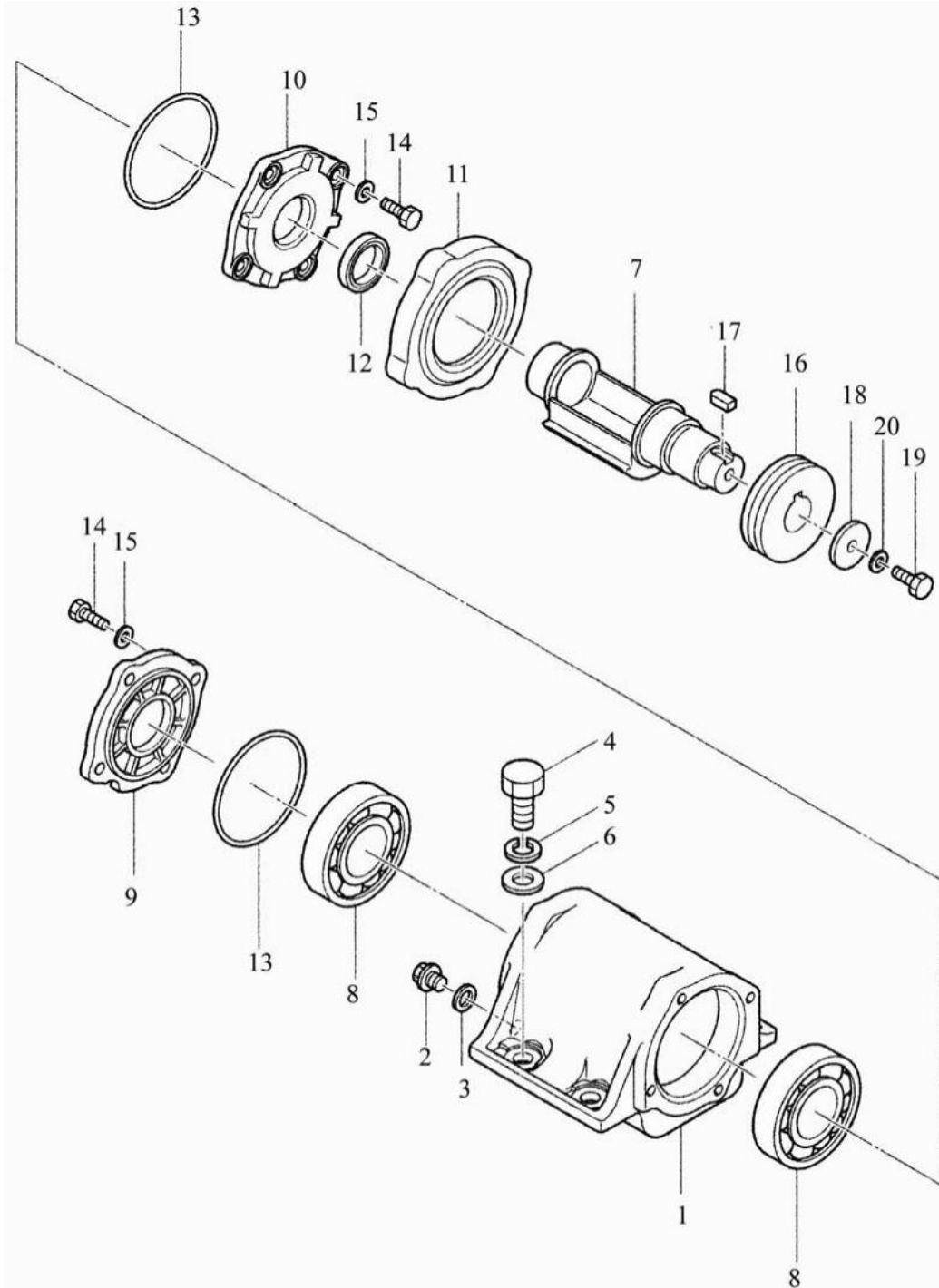

VIBRATOR: BPR1080 – PARTS LIST 2

Item #	Part #	Description	QTY	Remarks
-	651010	VIBRATOR ASSEMBLY	1	
1	65CPC-95-01A	VIBRATING CASE	1	
2	65CPC-95-02A	DRAIN PLUG, M12-1.25x10MM LG	1	
3	60848	SEALING WASHER, M12	1	
4	651078	HHCS, M16-2.0x45MM LG	4	
5	31260	LOCKWASHER, M16	4	
6	31211	PLAIN WASHER, M16	4	
7	65CPC-E60-14A	VIBRATION WEIGHTS	1	
8	60845	BEARING, 6211	2	
9	65CPC-95-09A	CASE RIGHT COVER	1	
10	65CPC-95-010A	CASE LEFT COVER	1	
11	65CPC-95-011A	BELT COVER GUARD	1	
12	60873	OIL SEAL 35x48x10	1	
13	60843	O-RING 100 x 3.1	2	
14	11619	HHCS, M8-1.25x25MM LG	8	
15	10998 11667	LOCKWASHER, M8 PLAIN WASHER, M8	8	
16	651113	PULLEY	1	
17	651094	KEY 8x7x20	1	
18	14998	FENDER WASHER M10	1	
19	13348	HHCS, M10-1.5x25MM LG	1	
20	11621	LOCKWASHER, M10	1	

BARTELL

BARTELL GLOBAL



Bartell Morrison Inc.
170 Traders Blvd E
Mississauga, Ontario, Canada
L4Z 1W7
Tel: 1-647-953-4100
Fax: 1-647-953-4101



Bartell Morrison (USA) LLC
200 Commerce Drive, Unit A
Freehold, New Jersey, USA
07728
Tel: 1-848-225-8100
Fax: 1-848-225-8101



Innovatech
4701 Allmond Ave
Louisville, Kentucky, USA
40209
Tel: (425) 405-9100
Fax: (425) 405-9101



SPE International
Honeyholes Lane
Dunholme, Lincoln, UK
LN2 3SU
Tel: +44 (0)1673 860709
Fax: +44 (0)1673 861119



**BARTELL
GLOBAL**

**5 BRANDS - 1 SOURCE FOR
GREAT EQUIPMENT**

BARTELL morrison SPE Innovatech CONTEC

BARTELLGLOBAL.COM