



INSTALLATION, OPERATION & MAINTENANCE MANUAL

J & JX SERIES SIDE DISCHARGE Electric Submersible Pumps

Single Phase
115 & 230V
Three Phase
208V, 230V, 460V & 575V

CAST IRON

SINGLE PHASE

J400
J750
J1500
J1500H

THREE PHASE

J08 J15H
J15 J22H
J22 J37H
J37 J55CH
J55C J75CH
J75C

316 STAINLESS STEEL

SINGLE PHASE

JX400SS
JX750SS
JX1500SS
JX1500HSS

THREE PHASE

JX08SS JX15HSS
JX15SS JX22HSS
JX22SS JX37HSS
JX37SS JX55CHSS
JX55CSS JX75CHSS
JX75CSS

Read this manual carefully before installing, operating or servicing these pump models. Observe all safety information. Failure to comply with instructions may result in personal injury and/or property damage. Please retain these instructions.

TABLE OF CONTENTS

INTRODUCTION.....	4
SAFETY	5
INSPECTION	6
PRE-INSTALLATION INSPECTION.....	6
OIL FILL QUANTITY/TYPE.....	7
PUMP INSTALLATION	8
POSITIONING THE PUMP	8
PUMP ROTATION.....	9
PUMP OPERATION.....	10
TYPICAL MANUAL DEWATERING-EFFLUENT INSTALLATION	10
TYPICAL AUTOMATIC DEWATERING-EFFLUENT INSTALLATION	11
INTENDED METHODS OF CONNECTION.....	12
SINGLE PHASE WIRING INSTRUCTIONS	13
THREE PHASE WIRING INSTRUCTIONS	13
TROUBLE SHOOTING	14
PUMP WILL NOT RUN	14
PUMP RUNS BUT DOES NOT DELIVER RATED CAPACITY	5
SERVICING YOUR SUBMERSIBLE PUMP	5
MAINTAINING YOUR PUMP	5
CHANGING SEAL OIL.....	5
EXPLODED VIEW OF J400, JX400SS.....	15
EXPLODED VIEW OF J750, J1500, J1500H.....	16
EXPLODED VIEW OF J08, J15, J15H	17
EXPLODED VIEW OF J22, J22H, J37, J37H,	18
EXPLODED VIEW OF J55C, JX55CSS, J55CH, JX55CHSS, J75C, JX75CSS, J75CH, JX75CHSS	19
EXPLODED VIEW OF JX750SS, JX1500SS, JX1500HSS (PRECISION CAST MODELS).....	20
EXPLODED VIEW OF JX08SS, JX15SS, JX15HSS (PRECISION CAST MODELS)	21
EXPLODED VIEW OF JX22SS, JX37SS (PRECISION CAST MODELS).....	22
J SERIES PARTS LIST	23
JX PRECISION CAST PARTS LIST	25
SINGLE PHASE WIRING DIAGRAM 115V & 230V W/O GOVERNOR SWITCH.....	27
MODELS J400, JX400SS	27
MODELS J750, JX750, J1500, JX1500H, JX1500HSS.....	28
THREE PHASE WIRING DIAGRAM	29
208V	29
MODELS J08, JX08SS, J15, JX15SS, J15H, JX15HSS, J22, JX22SS, J22H, JX22HSS, J37, JX37SS, J37H, J37HSS, J55C, J55CSS, J55CH, J55CHSS, J75C, JX75CSS, J75CH, J75CHSS.....	29
230V	30
MODELS J08, JX08SS, J15, JX15SS, J15H, JX15HSS, J22, JX22SS, J22H, JX22HSS, J37, JX37SS, J37H, J37HSS, J55C, J55CSS, J55CH, J55CHSS, J75C, JX75CSS, J75CH, J75CHSS.....	30
460V	31
MODELS J08, JX08SS, J15, JX15SS, J15H, JX15HSS, J22, JX22SS, J22H, JX22HSS, J37, JX37SS, J37H, J37HSS, J55C, J55CSS, J55CH, J55CHSS, J75C, JX75CSS, J75CH, J75CHSS.....	31
575V	32
MODELS J08, JX08SS, J15, JX15SS, J15H, JX15HSS, J22, JX22SS, J22H, JX22HSS, J37, JX37SS, J37H, J37HSS, J55C, J55CSS, J55CH, J55CHSS, J75C, JX75CSS, J75CH, J75CHSS.....	32
SEAL MINDER®	33
WARRANTY AND LIMITATION OF LIABILITY.....	35
START-UP REPORT FORM	36
NOTES:.....	39



INTRODUCTION

This Installation, Operation and Maintenance manual provides important information on safety and the proper inspection, disassembly, assembly and testing of the BJM Pumps® J & JX Series submersible pump. This manual also contains information to optimize performance and longevity of your **BJM Pumps** submersible pump.

The submersible J Series pumps are designed to pump water and municipal/industrial effluent wastewater. The JX Series pumps are designed to pump corrosive liquids in concentrations chemically compatible with 316SS and FKM. The J & JX Series pumps are not explosion proof. They are not designed to pump volatile or flammable liquids.

Note: Consult chemical resistance chart for compatibility between pump materials and liquid before operating pump.

If you have any questions regarding the inspection, disassembly, assembly or testing please contact your **BJM Pumps** distributor, or BJM Pumps, LLC.

BJM Pumps, LLC
123 Spencer Plain Rd.
Old Saybrook, CT 06475, USA

Fax: 860-399-7784
Phone: 877-256-7867
Phone: 860-399-5937

For assistance with your electric power source, please contact a certified electrician.

Please pay attention to the following alert notifications. They are used to notify operators and maintenance personnel to pay special attention to procedures, to avoid causing damage to the equipment, and to avoid situations that could be dangerous to personnel.

NOTE: Instructions to aid in installation, operation, and maintenance or which clarify a procedure.

⚠ DANGER

Immediate hazards that WILL result in severe personal injury or death. These instructions describe the procedure required and the injury which will result from failure to follow the procedure.

⚠ WARNING

Hazards or unsafe practices that COULD result in severe personal injury or death. These instructions describe the procedure required, and the injury which could result from failure to follow the procedure.

⚠ CAUTION

Hazards or unsafe practices which COULD result in personal injury or product or property damage. These instructions describe the procedure required and the possible damage which could result from failure to follow the procedure.



SAFETY

Pump installations are seldom identical. Each installation and application can vary due to many different factors. It is the owner/service mechanics responsibility to repair, service, and test to ensure that the pump integrity is not compromised according to this manual.

⚠ WARNING

Risk of electric shock – this pump has not been investigated for use in swimming pool areas.

⚠ DANGER

Do not pump flammable, inflammable or volatile liquids. Death or serious injury will result.

⚠ WARNING

Before attempting to open or service the pump:

- 1) Familiarize yourself with this manual.
- 2) Unplug or disconnect the pump power cable to ensure that the pump will remain inoperative.
- 3) Allow the pump to cool if overheated.

⚠ WARNING

Do not operate the pump with a worn or damaged electric power cable. Death or serious injury could occur.

⚠ WARNING

Never attempt to alter the length or repair any power cable with a splice. The pump motor and pump motor and cable must be completely waterproof. Damage to the pump or personal injury may result from alterations.

⚠ WARNING

After the pump has been installed, make sure that the pump and all piping are secure before operation.

⚠ WARNING

Do not lift the pump by the power cable piping or discharge hose. Attach proper lifting equipment to the lifting handle (or lifting rings) fitted to the pump. Do not suspend the pump by the power cable.

⚠ WARNING

Obtain the services of a qualified electrician to troubleshoot, test and/or service the electrical components of this pump.

⚠ CAUTION

Pumps and related equipment must be installed and operated according to all national, local and industry standards.



INSPECTION

Review all safety information before servicing pump.

The following are recommended installation practices/procedures for the pump. If there are questions in regards to your specific application, contact your local **BJM Pumps** distributor or BJM Pumps, LLC.

PRE-INSTALLATION INSPECTION

- 1) Check the pump for damage that may have occurred during shipment.
- 2) Inspect the pump for any cracks, dents, damaged threads, etc.
- 3) Check power cord (and Seal Minder® cord, if installed) for any cuts or damage.
- 4) Check for, and tighten any hardware that appears loose.
- 5) Carefully read all tags, decals and markings on the pump.

If anything appears to be abnormal, contact your **BJM Pumps** distributor or BJM Pumps, LLC. If damaged, the pump may need to be repaired before use. Do not install or use the pump until appropriate action has been taken.

Lubrication:

No additional lubrication is necessary. The shaft seal and bearings are fully lubricated from the factory. Seal oil should be checked once per year. See table below.



Note: For EPDM seals propylene glycol is used in the seal chamber

OIL FILL QUANTITY/TYPE

Models	Qty. oil in seal chamber		
	U.S. fl. oz.	C.C.	Type of oil
J400	5.1	150	ISO 32 NSF Food Mineral Grade
J750	9	265	ISO 32 NSF Food Mineral Grade
J1500	9	265	ISO 32 NSF Food Mineral Grade
J08	9	265	ISO 32 NSF Food Mineral Grade
J15	9	265	ISO 32 NSF Food Mineral Grade
J22	10.8	320	ISO 32 NSF Food Mineral Grade
J37	10.8	320	ISO 32 NSF Food Mineral Grade
J55C	45.6	1350	ISO 32 NSF Food Mineral Grade
J75C	45.6	1350	ISO 32 NSF Food Mineral Grade

Models	Qty. oil in seal chamber		
	U.S. fl. oz.	C.C.	U.S. fl. oz.
J1500H	9	265	ISO 32 NSF Food Mineral Grade
J15H	9	265	ISO 32 NSF Food Mineral Grade
J22H	10.8	320	ISO 32 NSF Food Mineral Grade
J37H	10.8	320	ISO 32 NSF Food Mineral Grade
J55CH	45.6	1350	ISO 32 NSF Food Mineral Grade
J75CH	45.6	1350	ISO 32 NSF Food Mineral Grade

Models	Qty. oil in seal chamber		
	U.S. fl. oz.	C.C.	Type of oil
JX400SS	5.1	150	ISO 32 NSF Food Mineral Grade
JX750SS	10.1	300	ISO 32 NSF Food Mineral Grade
JX1500SS	10.1	300	ISO 32 NSF Food Mineral Grade
JX08SS	10.1	300	ISO 32 NSF Food Mineral Grade
JX15SS	10.1	300	ISO 32 NSF Food Mineral Grade
JX22SS	13.5	400	ISO 32 NSF Food Mineral Grade
JX37SS	13.5	400	ISO 32 NSF Food Mineral Grade
JX55CSS	45.6	1350	ISO 32 NSF Food Mineral Grade
JX75CSS	45.6	1350	ISO 32 NSF Food Mineral Grade

Models	Qty. oil in seal chamber		
	U.S. fl. oz.	C.C.	Type of oil
JX1500HSS	10.1	300	ISO 32 NSF Food Mineral Grade
JX15HSS	10.1	300	ISO 32 NSF Food Mineral Grade
JX22HSS	13.5	400	ISO 32 NSF Food Mineral Grade
JX37HSS	13.5	400	ISO 32 NSF Food Mineral Grade
JX55CHSS	45.6	1350	ISO 32 NSF Food Mineral Grade
JX75CHSS	45.6	1350	ISO 32 NSF Food Mineral Grade



PUMP INSTALLATION

J & JX Series pumps have been evaluated for use with water or water based solutions. Please contact the manufacturer for additional information.

⚠ WARNING

Risk of electric shock. Pump models; J400, JX400, J750 & JX750 (115v) are supplied with a grounding conductor and grounding-type attachment plug. Pump models 230V single phase pumps and all three phase pumps do not come with electric plug connectors. To reduce the risk of electric shock, be certain that it is connected only to a properly grounded, grounding-type receptacle.

Lifting:

Attach a rope or lifting chain (not included) to the handle (or lifting rings) on the top of the pump.

⚠ CAUTION

Do not lift the pump by the power cable or discharge hose/piping. Proper lifting equipment (rope/chain) must be used.

POSITIONING THE PUMP

BJM Pumps, J & JX Series pumps are designed to operate fully or partially submerged. Do not run the pump dry. Refer to data sheet for minimum submersion depth for your particular model. Data sheets can be obtained by calling BJM Pumps, LLC at 860-399-5937. As a general rule, J and JX Series side discharge pumps can pump down to a level above the suction screen. Pumping lower than screen will permit air to enter the pump and cavitate, lose prime or become air bound.

⚠ CAUTION

- Do not run the pump dry.
- Pump liquid should not exceed a maximum temperature of 104°F.
- Never place the pump on loose or soft ground. The pump may sink, preventing water from reaching the impeller. Place on a solid surface or suspend the pump with a lifting rope/chain. The J & JX Series pumps are provided with a suction strainer to prevent large solids from clogging the impeller. Any spherical solids which pass through the strainer should pass through the pump.
- For maximum pumping capacity, use the proper size non-collapsible hose or rigid piping. A check valve may be installed after the discharge to prevent back flow when the pump is shut off.



PUMP ROTATION

Two ways to check the correct pump rotation:

1. By looking at the impeller; the rotation of the impeller should be counter clockwise as shown in the picture below.

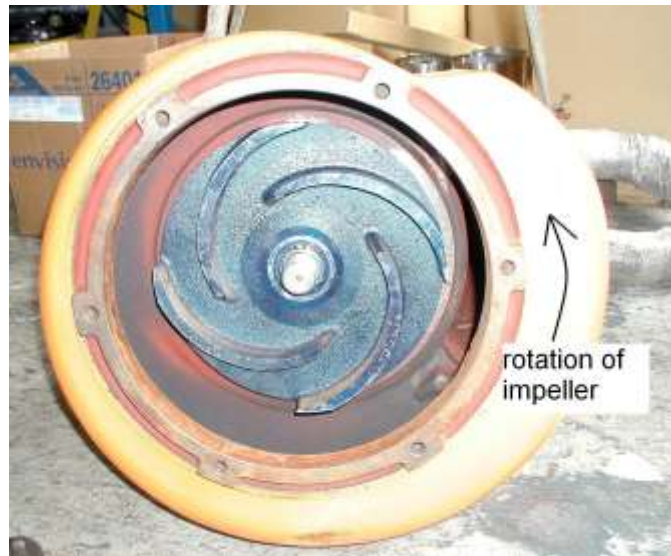

2. By looking from the top of the pump. Since the impeller cannot be seen, the best way to check the rotation is to check the kick back motion of the pump when the pump just starts. The kick back motion of the pump should be counter clockwise as shown in the picture below.





PUMP OPERATION

⚠ WARNING

This pump is designed to handle dirty water that contains some solids. It is not designed to pump volatile or flammable liquids. Do not attempt to pump any liquids which may damage the pump or endanger personnel as a result of pump failure.

⚠ DANGER

Do not operate this pump where explosive vapors or flammable material exist. Death or Serious injury will result.

TYPICAL MANUAL DEWATERING-EFFLUENT INSTALLATION

NOTE: Maximum recommended starts should not exceed 10 times per hour.

All J & JX models are provided with a 33" (10m) power cord (exception; J1500, JX1500, J1500H) are supplied with a 50' (15m) power cord. **NEVER** splice the power cable due to safety and warranty considerations. Always keep the plug end dry.

Note: 230V, single phase and 208V, 230V, 460V & 575V three phase units do not have a plug and have to be provided separately.

⚠ WARNING

Do not alter the length or repair any power cable with a splice. The pump motor and cable must be completely waterproof. Damage to the pump or personal injury may result from alterations.

For manual operation: 115 volt: plug the power cable into any 115 volt grounded receptacle. 208, 230, 460 & 575 volt: Attach the proper plug, connect directly to the power source or control box. Check the direction of the rotation. Tilt the pump and start it. It should twist in the opposite direction of the arrow (on pump). It is recommended that a Ground Fault Interrupter (GFI) type receptacle (or equivalent) be used.

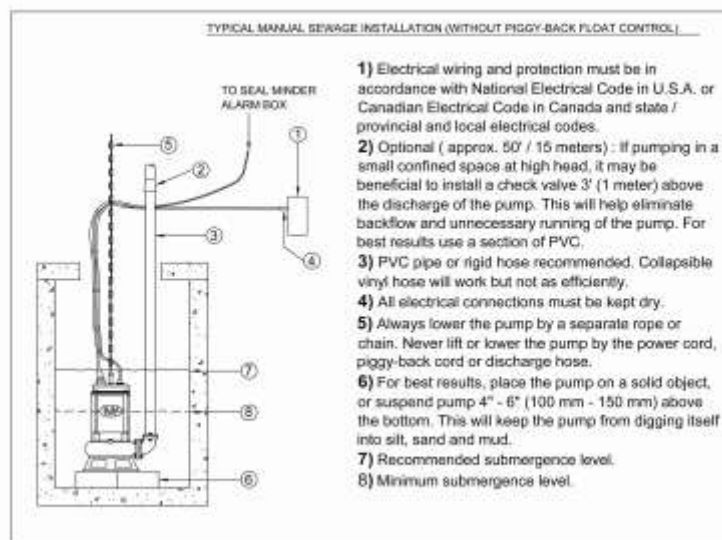



Single phase pumps always use a three-prong grounded receptacle. It is recommended that a Ground Fault Interrupter (GFI) type receptacle (or equivalent) be used.

STOPPING

To stop the pump (manual and automatic mode), unplug it from the power source, turn off the breaker, or turn the power source off (generator).

TYPICAL AUTOMATIC DEWATERING-EFFLUENT INSTALLATION

NOTE: Maximum recommended starts should not exceed 10 times per hour.

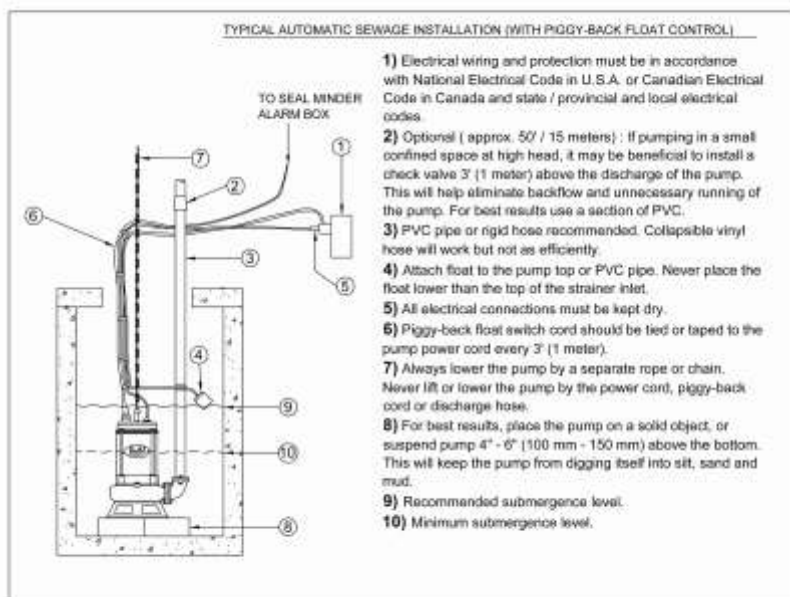

Float switches (wired into the pump motor or piggy-back style) are available from the factory as an option.

Note: 208, 230V 460V & 575V pumps do not have a plug installed.

Three phase pumps need a separate control box with float(s) for automatic operation.

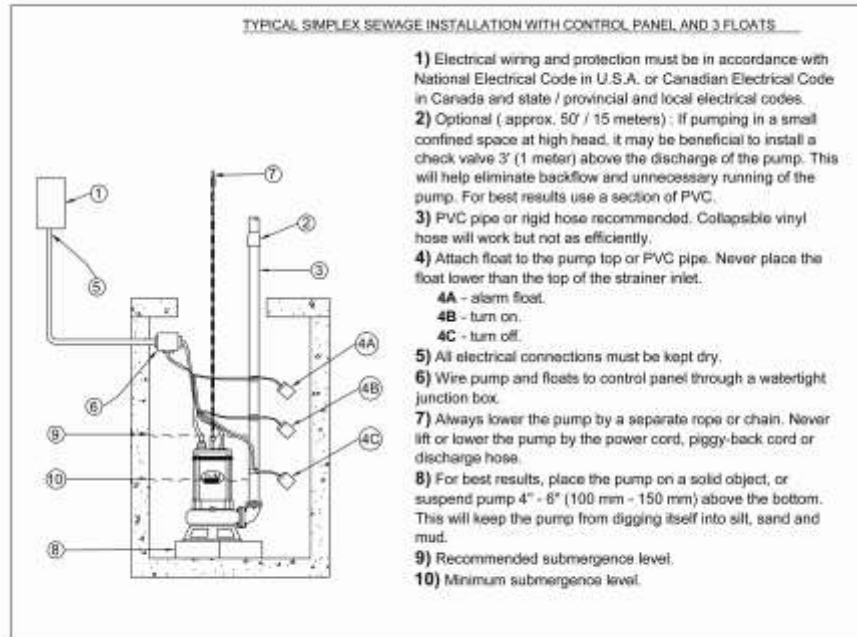

STOPPING

To stop the pump (manual and automatic mode), unplug it from the power source, turn off the breaker, or turn the power source off (generator).

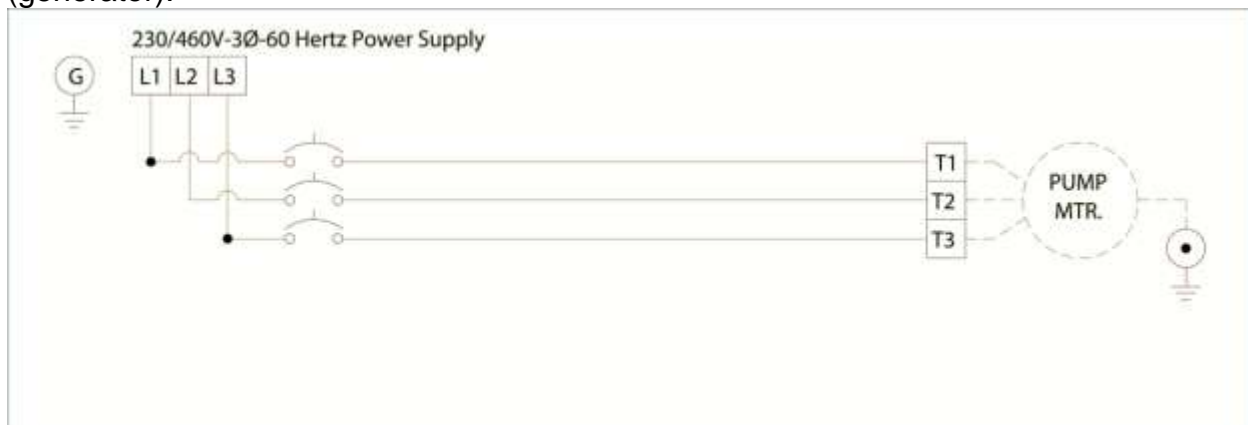

Typical 3 phase manual control 1

INTENDED METHODS OF CONNECTION



Use with approved motor control that matches motor input in full load amperes. "UTILISER UN DÉMARREUR APPROUVÉ CONVARIANT AU COURANT À PLEINE CHARGE DU MOTEUR."

BJM Pumps has been evaluated for use with water or water based solutions. Please contact the manufacturer for additional information.



SINGLE PHASE WIRING INSTRUCTIONS



FOR YOUR PROTECTION, ALWAYS DISCONNECT PUMP FROM ITS POWER SOURCE BEFORE HANDLING. Single phase pumps are supplied with a three prong grounded plug to help protect you against the possibility of electrical shock. **DO NOT UNDER ANY CIRCUMSTANCES REMOVE THE GROUND PIN.** The three prong plug **must** be inserted into a mating three prong grounded receptacle. **IF** the installation does not have such a receptacle it must be changed to the proper type, wired and grounded in accordance with the National Electrical Code and all applicable local codes and ordinances



“Risk of electrical shock” Do not remove power supply cord and strain relief or connect conduit directly to the pump.



Installation and checking of electrical circuits and hardware should be performed by a qualified licensed electrician.

THREE PHASE WIRING INSTRUCTIONS



FOR YOUR PROTECTION, ALWAYS DISCONNECT PUMP FROM ITS POWER SOURCE BEFORE HANDLING.

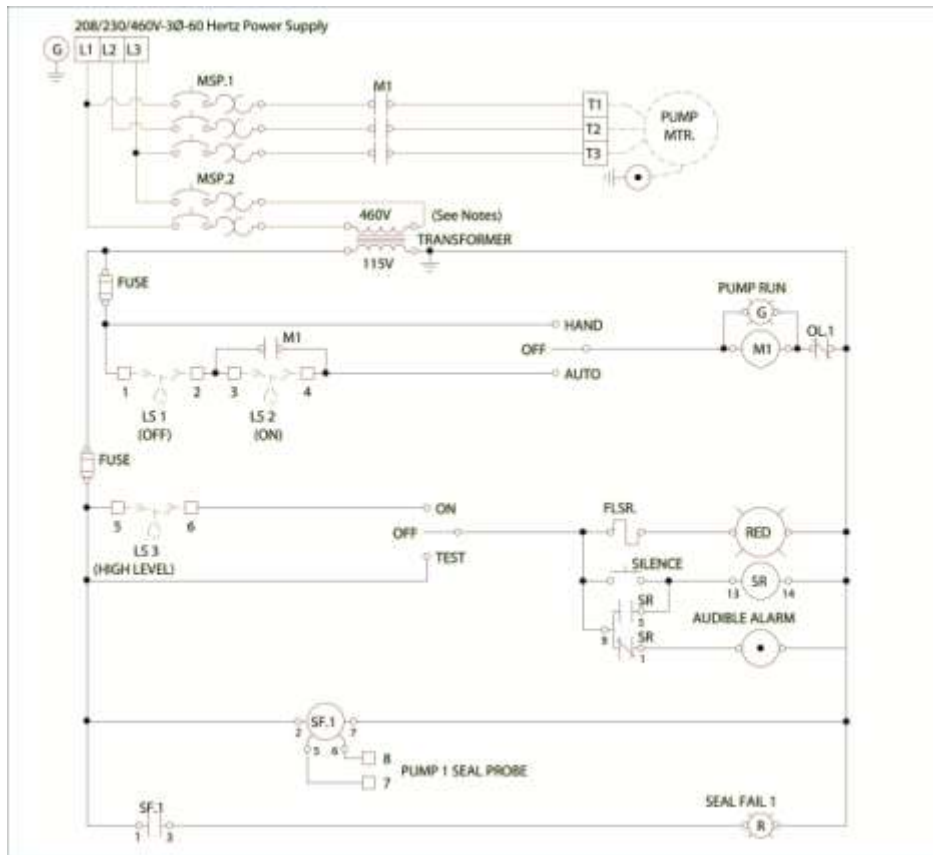

Typical 3 phase Auto Control 1



⚠ WARNING

“Risk of electrical shock” Do not remove power supply cord and strain relief or connect conduit directly to the pump.

⚠ WARNING

Installation and checking of electrical circuits and hardware should be performed by a qualified licensed electrician.

To automatically operate a non-automatic three phase pump, a control panel is required. Follow the instructions provided with the panel to wire the system. For automatic three phase pumps see automatic three phase wiring diagram.

Before installing a pump, check the pump rotation to insure that wiring has been connected properly to power source, and that the green lead of power cord (See wiring diagram), is connected to a valid ground, momentarily energize the pump, observing the directions of kick back due to starting torque. Rotation is correct if kick back is in the opposite direction of rotation arrow on the pump casing. If rotation is not correct, switching of any two power leads other than ground will provide the proper rotation.

Three phase pumps have integral motor overload protection. It is recommended that all three phase pumps using a motor starting device also incorporate motor overload protection. Pumps **must** be installed in accordance with the National Electrical Code and all applicable local codes and ordinances. Pumps are not to be installed in locations classified as hazardous in accordance with National Electrical Code, ANSI/NFPA 70.

Connect pump to a junction box, outlet box, control box, enclosure with a wiring compartment that meets NEC and local electrical codes. The provision for supply connection shall reduce the risk of water entry during temporary, limited submersion and shall comply with the applicable requirements of the Standard for Enclosures for Electrical Equipment, UL 50, or the standard for Metallic Outlet Boxes, UL 514A, and the standard for Motor-Operated Water Pumps. UL 778.

TROUBLE SHOOTING

⚠ WARNING

Disconnect the power source to the pump BEFORE attempting any type of trouble shooting, service or repair.

PUMP WILL NOT RUN

1. Check power supply (fuses, breaker). Reset power.
2. Blocked impeller. Remove strainer, check and clean.
3. Defective cable or incorrect wiring.
4. Strainer clogged. Check and clean as necessary.
5. Float switch tangled/obstructed. Clean and free float switch from obstruction.
6. Float switch defective. Replace float switch.
7. Pump overheated or temperature of liquid exceeds pump operating temperature.



Warning: Pump will restart automatically when motor over-heat protection switch cools.

PUMP RUNS BUT DOES NOT DELIVER RATED CAPACITY

1. Discharge line clogged, restricted or hose kinked. Check discharge hose/pipe.
2. Worn impeller and/or suction cover. Inspect and replace as necessary.
3. Pump overloaded due to liquid pumped being too thick.
4. Pumping air. Check liquid level and position of pump.
5. Excessive voltage drops due to long cables.
6. Three phase only; pump running backwards, check rotation.

SERVICING YOUR SUBMERSIBLE PUMP

Pump should be disconnected from the electric power supply before proceeding to do any service or maintenance.

To service or repair your pump, please contact your local **BJM Pumps** distributor. Service should only be performed by a qualified electrician.

MAINTAINING YOUR PUMP

- Pump should be disconnected from the electric power supply before proceeding to do any service or maintenance.
- Pump should be inspected at regular intervals.
- More frequent inspections are required if the pump is used in a harsh environment.
- Preventative maintenance should be performed to reduce the chance of premature failure.
- Worn impellers and lip seals should be replaced.
- Cut or cracked power cords must be replaced. **(Never operate a pump with a cut, cracked or damaged power cord.)**
- Seal oil should be checked once per year.
- Maintenance should always be done when taking a pump out of service before storage.
 - 1) Clean pump of dirt and other build up.
 - 2) Check condition of oil around the shaft seals.
 - 3) Check hydraulic parts: check for wear.
 - 4) Inspect power cable. Make sure that it is free of nicks or cuts.

CHANGING SEAL OIL

Changing the seal oil in the J & JX Series pumps is very easy.

- 1) Make sure that the pump cable is disconnected from the power source.
- 2) Lay the pump down on its side.
- 3) Remove the screws that hold the bottom plate in place.
- 4) Remove bottom plate.
- 5) Remove screws holding the suction cover.
- 6) Remove the suction cover.
- 7) Remove the impeller.



- 8) Remove the inspection screw for the oil chamber (pos#50-08). Pour out a small sample of the oil. If it is milky white, or contains water, then the oil and possible, the mechanical seal, should be changed. If an oil change is needed:
- 9) Remove the screws that hold the oil chamber cover in place & remove the oil.
- 10) Replace the mechanical seal if necessary.
- 11) Replace the oil.
- 12) Assemble the pump.

EXPLODED VIEW OF J400, JX400SS

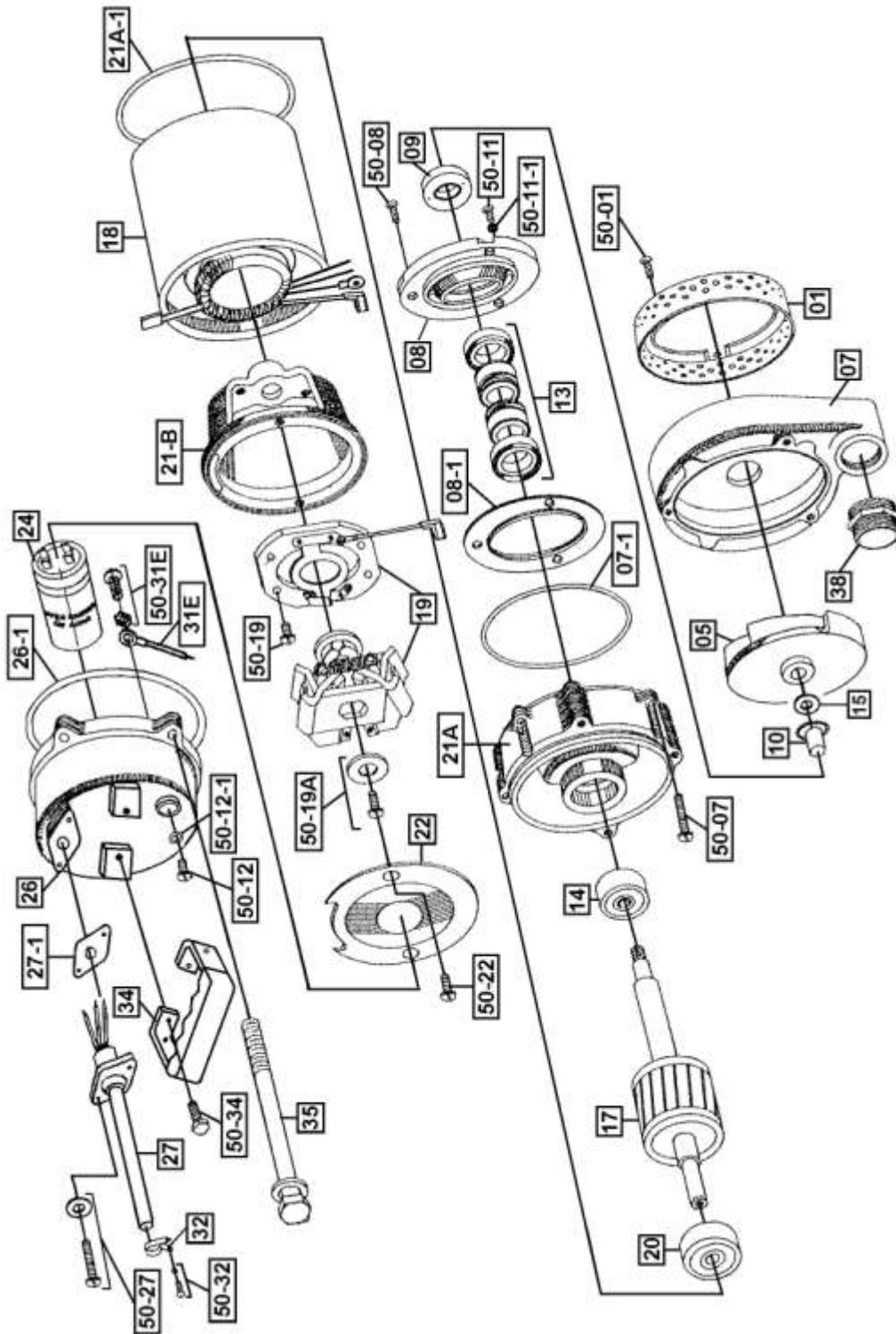



EXPLODED VIEW OF J750, J1500, J1500H

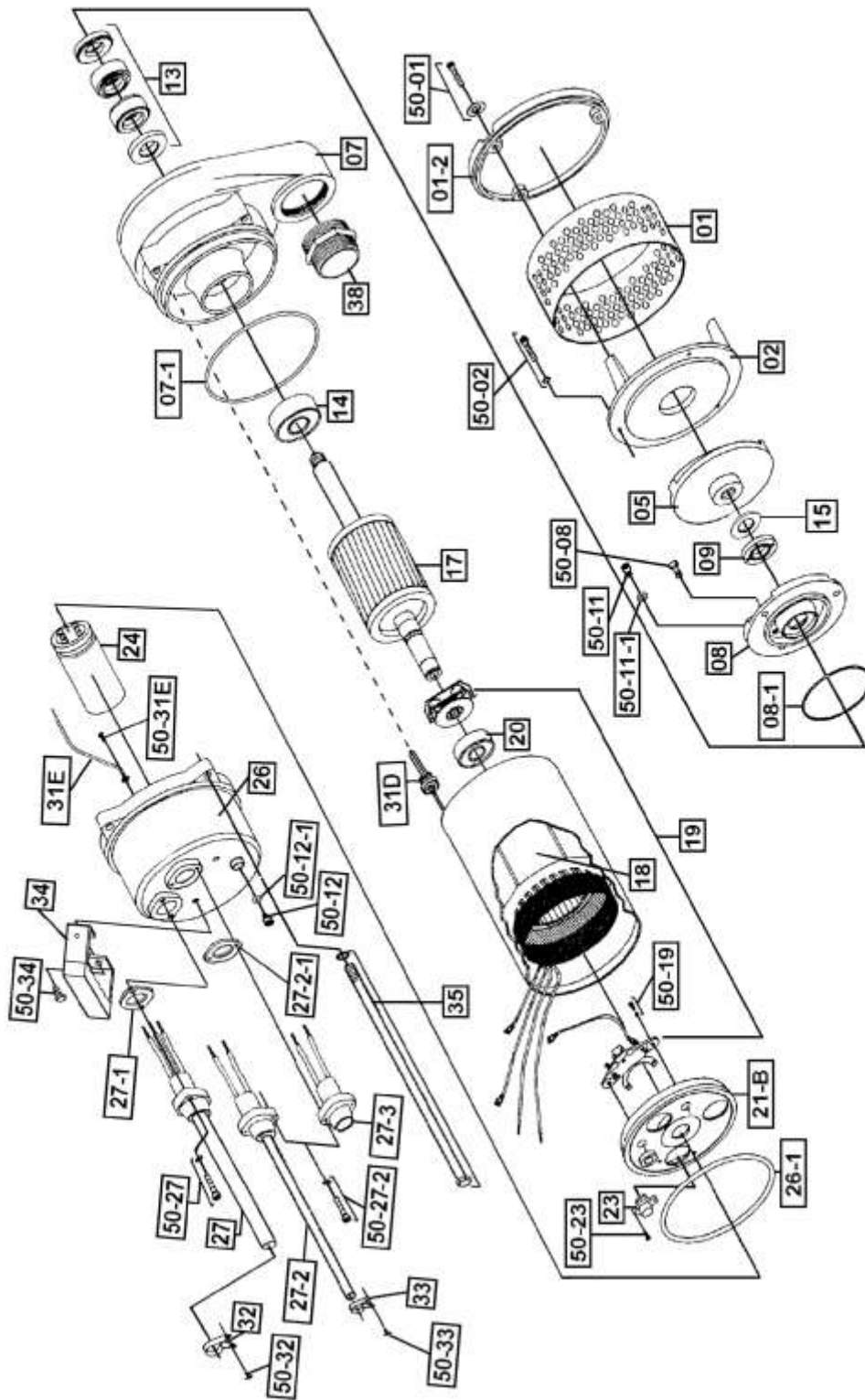



EXPLODED VIEW OF J08, J15, J15H

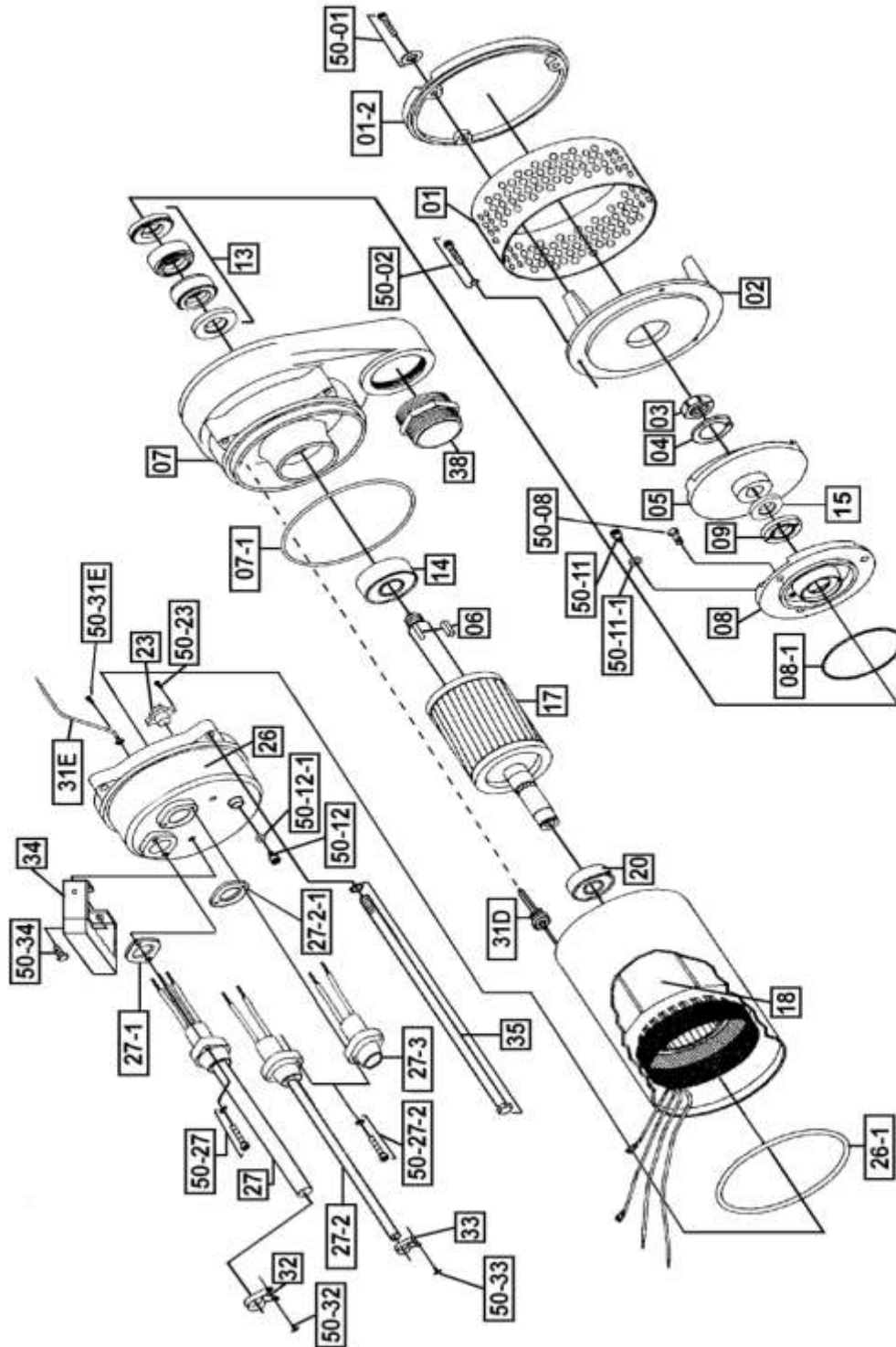



EXPLODED VIEW OF J22, J22H, J37, J37H

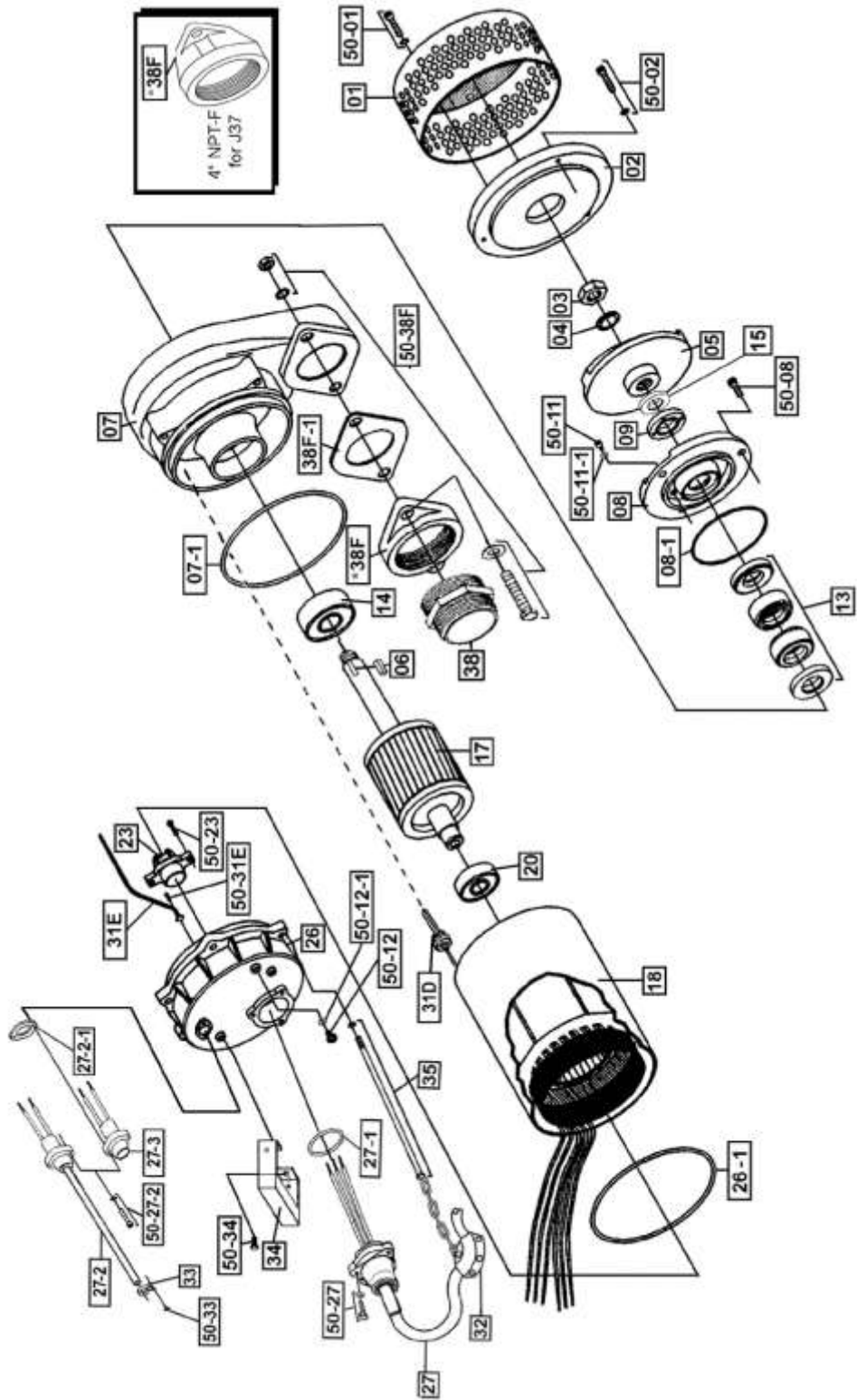



EXPLODED VIEW OF J55C, JX55CSS, J55CH, JX55CHSS, J75C, JX75CSS, J75CH, JX75CHSS

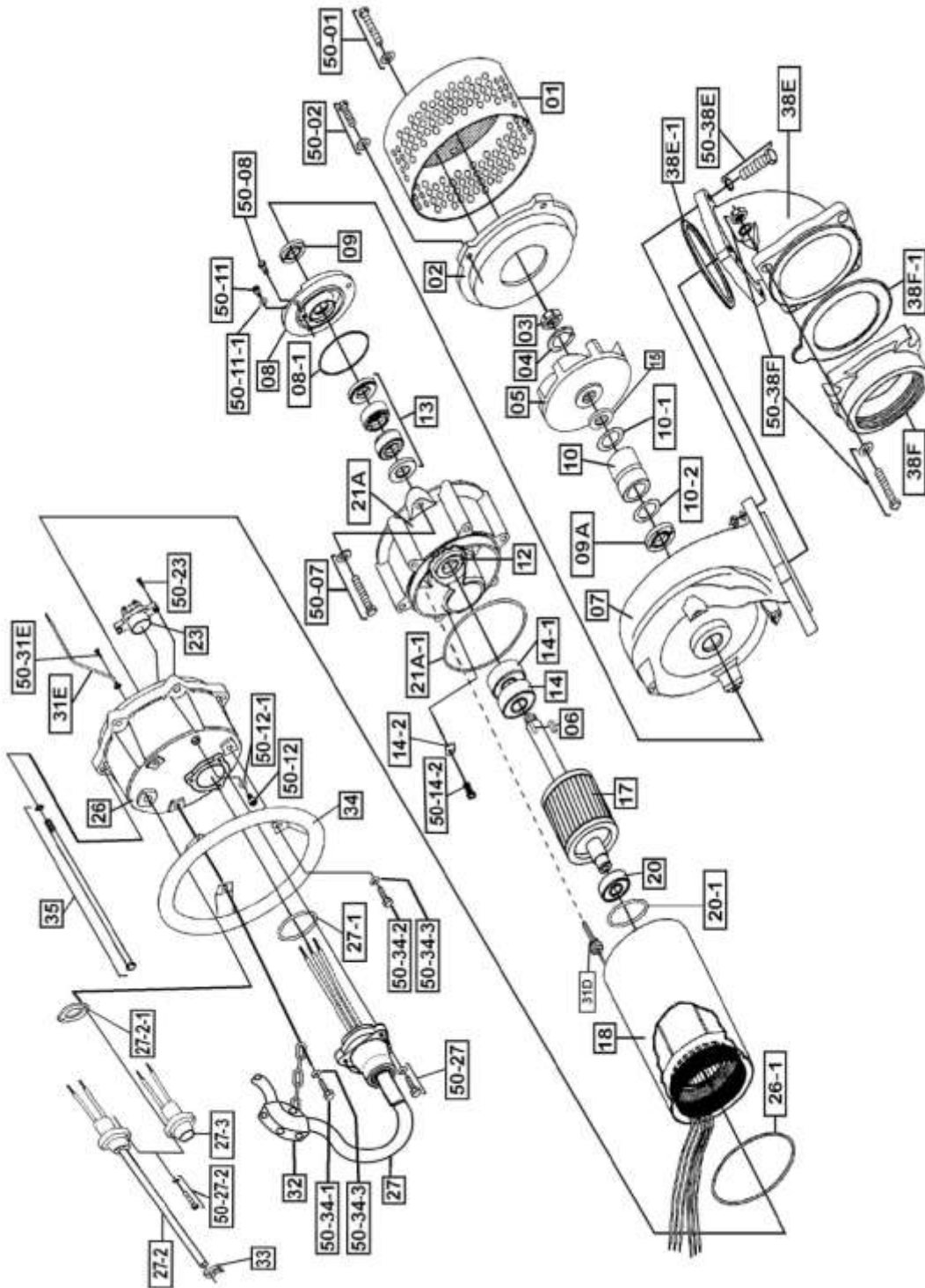



EXPLODED VIEW OF JX750SS, JX1500SS, JX1500HSS (PRECISION CAST MODELS)

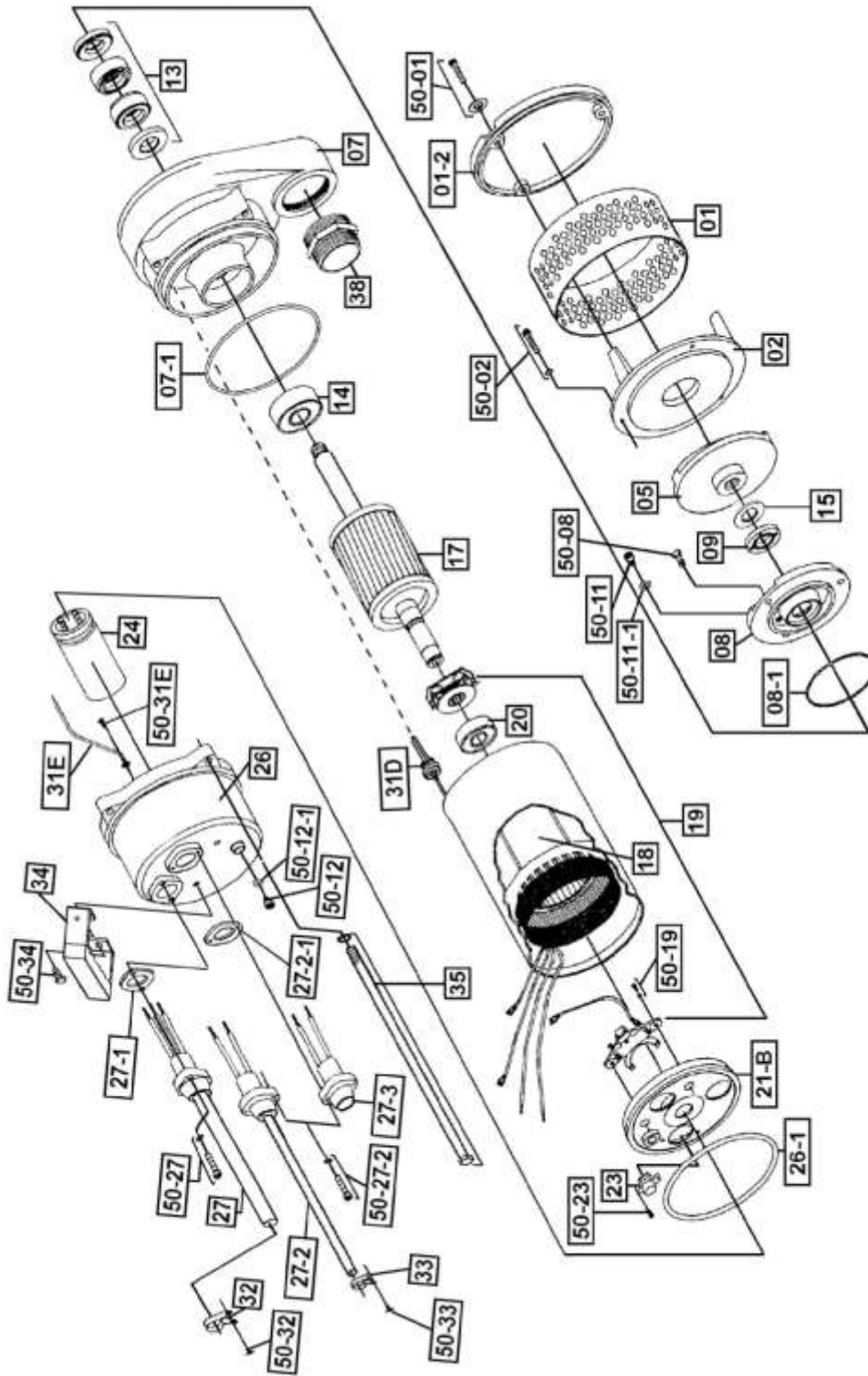



EXPLODED VIEW OF JX08SS, JX15SS, JX15HSS (PRECISION CAST MODELS)

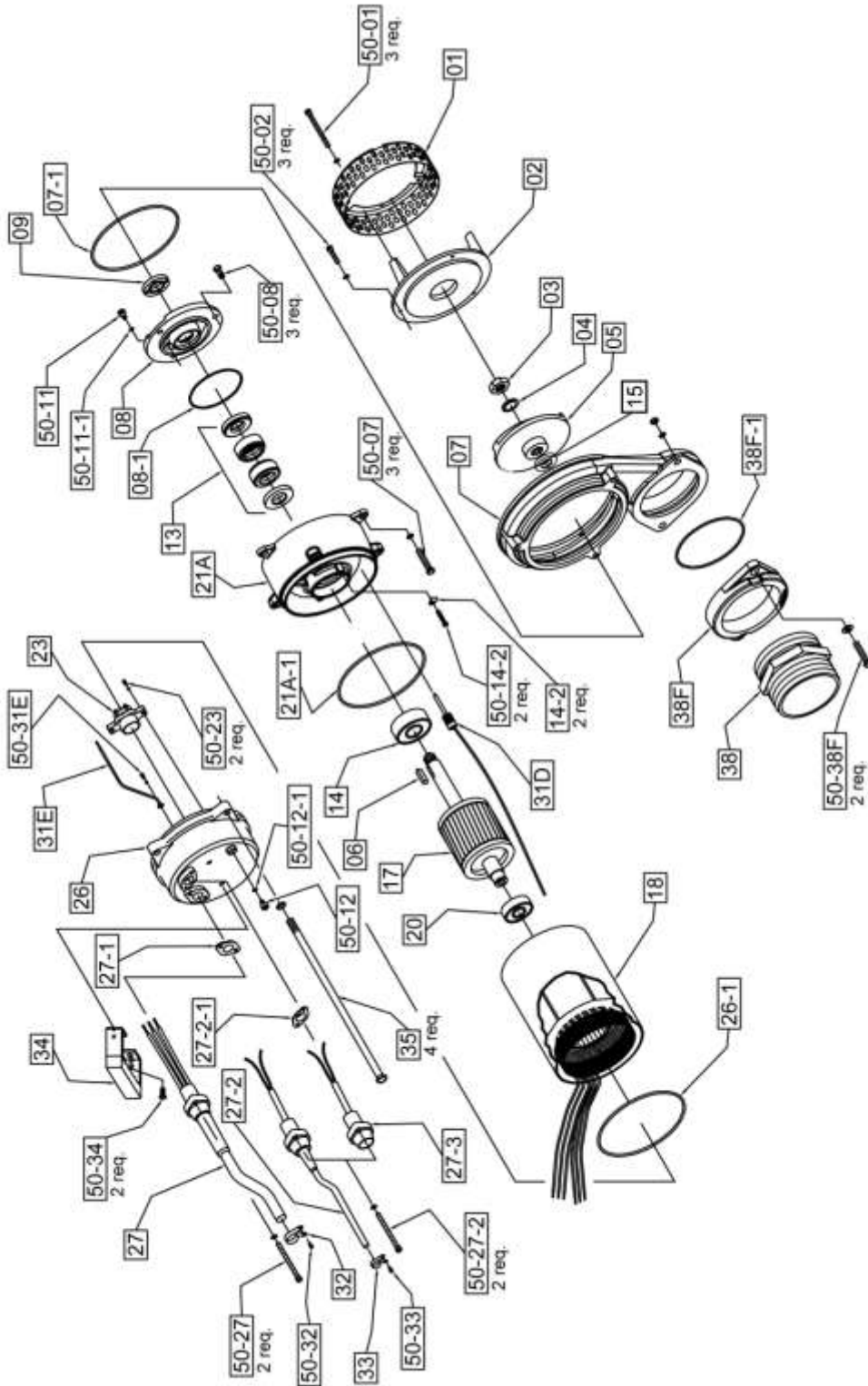



EXPLODED VIEW OF JX22SS, JX37SS (PRECISION CAST MODELS)

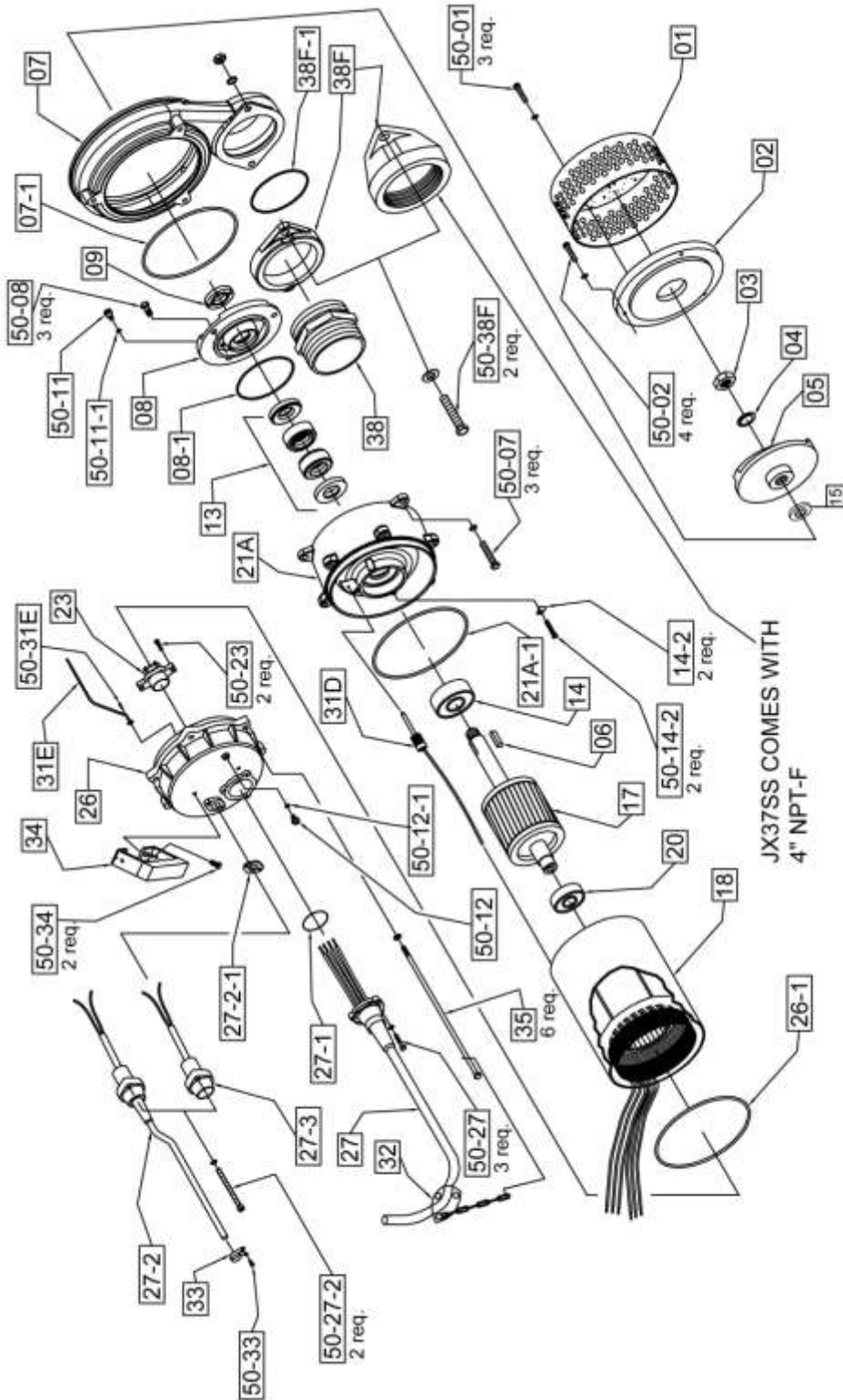

J SERIES PARTS LIST

	Pump Model	J150	J400	J750	J1500	J1500H	J08	J15	J15H	J22	J22H	J37	J37H	J55C	J55CH	J75C	J75CH
Pos. No.	Part Description	Item #	Item #	Item #	Item #	Item #	Item #	Item #	Item #	Item #	Item #	Item #	Item #	Item #	Item #	Item #	Item #
01	Strainer with Bottom Plate	201979	201964	-	-	-	-	-	-	201973	201973	201973	201973	201976	201976	201976	201976
01	Strainer	-	-	201969	201969	201969	201969	201969	201969	-	-	-	-	-	-	-	-
01-2	Bottom Plate	-	-	202007	202007	202007	202007	202007	202007	-	-	-	-	-	-	-	-
02	Suction Cover	-	-	202026	202026	202026	202026	202026	202026	202009	202011	202009	202011	202031	202032	202031	202032
03	Impeller Nut	202890	-	-	-	-	202894	202894	202894	202894	202894	202894	202894	202895	202895	202895	202895
04	Lock washer	-	-	-	-	-	202907	202907	202907	202907	202907	202907	202907	202904	202904	202904	202904
05	Impeller	202921	202055	202930	202062	202064	202933	202067	202069	202937	202072	202074	202076	202078	202079	202082	202083
06	Impeller Key	-	-	-	-	-	202140	202140	202140	202140	202140	202140	202140	202141	202141	202141	202141
07	Pump Housing	202988	202993	202163	202165	202163	202163	202165	202163	202167	202167	202167	202167	203007	203007	203007	203007
07 -1	O-Ring (Kit Only)	Kit	Kit	Kit	Kit	Kit	Kit	Kit	Kit	Kit	Kit	Kit	Kit	Kit	Kit	Kit	Kit
08	Oil Chamber Cover	202207	202207	202211	202211	202211	202211	202211	202211	202211	202211	202211	202211	203043	203043	203043	203043
08 -1	O-Ring (Kit Only)	Kit	Kit	Kit	Kit	Kit	Kit	Kit	Kit	Kit	Kit	Kit	Kit	Kit	Kit	Kit	Kit
09	Lip Seal Buna-N	202229	202229	202231	202231	202231	202231	202231	202231	202231	202231	202231	202231	203055	203055	203055	203055
09	Lip Seal FKM (Optional)	202230	202230	202233	202233	202233	202233	202233	202233	202233	202233	202233	202233	203058	203058	203058	203058
09	Lip Seal EPDM (Optional)	203050	203050	203053	203053	203053	203053	203053	203053	203053	203053	203053	203053	203056	203056	203056	203056
09A	Double Lip Seal Buna-N	-	-	-	-	-	-	-	-	-	-	-	-	202249	202249	202249	202249
09A	Double Lip Seal FKM (Optional)	-	-	-	-	-	-	-	-	-	-	-	-	202240	202240	202240	202240
09A	Double Lip Seal EPDM (Optional)	-	-	-	-	-	-	-	-	-	-	-	-	203060	203060	203060	203060
10	Shaft Sleeve	202258	202258	-	-	-	-	-	-	-	-	-	-	202256	202256	202256	202256
10-1	O-Ring (Kit Only)	-	-	-	-	-	-	-	-	-	-	-	-	Kit	Kit	Kit	Kit
10-2	O-Ring (Kit Only)	-	-	-	-	-	-	-	-	-	-	-	-	Kit	Kit	Kit	Kit
12	Lip Seal for Lower Bearing	-	-	-	-	-	-	-	-	-	-	-	-	202236	202236	202236	202236
13	Mechanical Seal Buna-N	202269	202259	200501	200501	200501	200501	200501	200501	200501	200501	200501	200501	200305	200305	200305	200305
13	Mechanical Seal FKM**	-	202260	200500	200500	200500	200500	200500	200500	200500	200500	200500	200500	200304	200304	200304	200304
14	Lower Ball Bearing	200957	200493	200958	200958	200958	200958	200958	200958	200959	200959	200959	200959	200960	200960	200961	200961
14-1	Lower Ball Bearing	-	-	-	-	-	-	-	-	-	-	-	-	200960	200960	200961	200961
14-2	Lower Bearing Retainer Clip	-	-	-	-	-	-	-	-	-	-	-	-	202279	202279	202279	202279
15	Impeller Shim Kit	-	-	200481	200481	200480	200480	200480	200480	200480	200480	200480	200480	200479	200479	200479	200479
17	Rotor w/ Shaft 115/230V, 1PH	202299	202302	203086	203091	203091	-	-	-	-	-	-	-	-	-	-	-
17	Rotor w/ Shaft, 3 PH	-	-	-	-	-	202306	202310	202310	202314	202314	202318	202318	202343	202343	202345	202345
18	Stator w/Casing, 115V, 1PH	-	200509	200511	-	-	-	-	-	-	-	-	-	-	-	-	-
18	Stator w/Casing, 230V, 1PH	-	200521	200570	200514	200514	-	-	-	-	-	-	-	-	-	-	-
18	Stator w/Casing, 208V, 3PH	-	-	-	-	-	200524	200528	200528	200532	200532	200536	200536	200665	200665	-	-
18	Stator w/Casing, 230/460V, 3PH	-	-	-	-	-	200546	200550	200550	200554	200554	200558	200558	200562	200562	200566	200566
18	Stator w/Casing, 575V, 3PH	-	-	-	-	-	200588	200592	200592	200596	200596	200600	200600	200605	200605	200609	200609
19	Governor Switch w/Switch Plate	-	202359	202360	202360	202360	-	-	-	-	-	-	-	-	-	-	-
20	Upper Ball Bearing	200966	200957	200967	200967	200967	200967	200967	200967	200958	200958	200958	200958	200959	200959	200959	200959
20-1	O-Ring (Kit Only)	-	-	-	-	-	-	-	-	-	-	-	-	Kit	Kit	Kit	Kit
21A	Oil Chamber	202990	200498	-	-	-	-	-	-	-	-	-	-	202178	202178	202169	202169
21A-1	O-Ring (Kit Only)	Kit	Kit	-	-	-	-	-	-	-	-	-	-	Kit	Kit	Kit	Kit
21B	Motor Cover	-	202365	202368	202368	202368	-	-	-	-	-	-	-	-	-	-	-
22	Cover Plate Upper	-	202380	-	-	-	-	-	-	-	-	-	-	-	-	-	-
23	Overload 115V, 1PH	-	-	202383	-	-	-	-	-	-	-	-	-	-	-	-	-
23	Overload 230V, 1PH	-	-	202395	202383	202383	-	-	-	-	-	-	-	-	-	-	-
23	Overload 208V, 3PH	-	-	-	-	-	202385	202388	202388	202390	202390	202392	202392	202394	202394	-	-
23	Overload 230V, 3PH	-	-	-	-	-	202385	202388	202388	202390	202390	202392	202392	202394	202394	202396	202396
23	Overload 460V, 3PH	-	-	-	-	-	202387	202388	202388	202389	202389	202391	202391	202393	202393	202394	202394

23	Overload 575V, 3PH	-	-	-	-	-	202399	202387	202387	202386	202386	202389	202389	202391	202391	202393	202393
24	Capacitor 115V	202414	202415	202417	-	-	-	-	-	-	-	-	-	-	-	-	-
24	Capacitor 230V	-	202416	202418	202420	202420	-	-	-	-	-	-	-	-	-	-	-
26	Pump Top Cover	203119	203120	202433	202433	202433	202435	202435	202435	202445	202445	202445	202445	202439	202439	202439	202439
26-1	O-Ring (Kit Only)	Kit	Kit	Kit	Kit	Kit	Kit	Kit	Kit	Kit	Kit	Kit	Kit	Kit	Kit	Kit	Kit
27	Power Cable w/ Gland-115V, 1PH	201682	204257	204258	-	-	-	-	-	-	-	-	-	-	-	-	-
27	Power Cable w/ Gland-230V, 1PH, No Plug	-	201684	201694	204260	204260	-	-	-	-	-	-	-	-	-	-	-
27	Power Cable w/ Gland- 3PH	-	-	-	-	-	201701	201701	201701	203442	203442	203444	203444	203446	203446	203446	203446
27-1	O-Ring (Kit Only)	Kit	Kit	Kit	Kit	Kit	Kit	Kit	Kit	Kit	Kit	Kit	Kit	Kit	Kit	Kit	Kit
27-2	Seal Minder Cable	-	-	202763	202764	202764	202763	202763	202763	202763	202763	202763	202763	202763	202763	202763	202763
27-2-1	O-Ring (Kit Only)	-	-	Kit	Kit	Kit	Kit	Kit	Kit	Kit	Kit	Kit	Kit	Kit	Kit	Kit	Kit
27-3	Oil Sensor Cap	-	-	203139	203139	203139	203139	203139	203139	203139	203139	203139	203139	203139	203139	203139	203139
31D	Seal Minder Probe	-	-	202409	202409	202409	202409	202409	202409	203998	203998	203998	203998	204000	204000	204000	204000
31E	Ground Wire w/Ring Term.	203145	203145	203145	203145	203145	203145	203145	203145	203145	203145	203145	203145	203145	203145	203145	203145
32	Power Cord Line Clip / Strain Relief	-	203161	203161	203161	203161	203161	203161	203161	204161	204161	202497	202497	202497	202497	202497	202497
33	Seal Minder Cable Line Clip	-	-	203163	203163	203163	203163	203163	203163	203163	203163	203163	203163	203163	203163	203163	203163
34	Handle	203167	202517	202517	202517	202517	202517	202517	202517	202517	202517	202517	202517	203171	203171	203171	203171
35	Holding Rods	-	202665	202666	202668	202668	202669	202670	202670	202671	202671	202672	202672	202673	202673	202674	202674
38	Discharge Nipple	-	202531	202531	202534	202531	202531	202534	202531	202534	202531	202534	202531	-	-	-	-
38E	Discharge Elbow	-	-	-	-	-	-	-	-	-	-	-	-	202560	202560	202560	202560
38E-1	Gasket Discharge Elbow Buna-N	-	-	-	-	-	-	-	-	-	-	-	-	203210	203210	203210	203210
38E-1	Gasket Discharge Elbow FKM (Optional)	-	-	-	-	-	-	-	-	-	-	-	-	203211	203211	203211	203211
38F	Discharge Flange	-	-	-	-	-	-	-	-	202545	202543	202545	202543	202537	202538	202537	202537
38F	Discharge Connection 4" FNPT	-	-	-	-	-	-	-	-	202552	-	202552	-	-	-	-	-
38F-1	Gasket -Discharge Flange Buna-N	-	-	-	-	-	-	-	-	202659	202659	202659	202659	203210	203210	203210	203210
38F-1	Gasket - Discharge Flange FKM (Optional)	-	-	-	-	-	-	-	-	202660	202660	202660	202660	203211	203211	203211	203211
50-01	Bolt - Strainer/Stand	203233	202694	203238	203238	203238	203238	203238	203238	203231	203231	203231	203231	203229	203229	203229	203229
50-02	Screw	-	-	203216	203216	203216	203216	203216	203216	203228	203228	203228	203228	203229	203229	203229	203229
50-07	Screw	203217	203216	-	-	-	-	-	-	-	-	-	-	203229	203229	203229	203229
50-08	Screw	203233	203215	203219	203219	203219	203219	203219	203219	203219	203219	203219	203219	203246	203246	203246	203246
50-11	Screw	203218	203218	203218	203218	203218	203218	203218	203218	203218	203218	203218	203218	203218	203218	203218	203218
50-11-1	O-Ring (Kit Only)	Kit	Kit	Kit	Kit	Kit	Kit	Kit	Kit	Kit	Kit	Kit	Kit	Kit	Kit	Kit	Kit
50-12	Screw	-	203218	203218	203218	203218	203218	203218	203218	203218	203218	203218	203218	203218	203218	203218	203218
50-12-1	O-Ring (Kit Only)	-	Kit	Kit	Kit	Kit	Kit	Kit	Kit	Kit	Kit	Kit	Kit	Kit	Kit	Kit	Kit
50-14-2	Screw	-	-	-	-	-	-	-	-	-	-	-	-	203219	203219	203219	203219
50-19A	Screw	-	203215	-	-	-	-	-	-	-	-	-	-	-	-	-	-
50-19	Screw	-	202693	202693	202693	202693	-	-	-	-	-	-	-	-	-	-	-
50-21A	Screw	202702	-	-	-	-	-	-	-	-	-	-	-	-	-	-	-
50-22	Screw	-	202692	-	-	-	-	-	-	-	-	-	-	-	-	-	-
50-23	Screw	-	-	202700	202700	202700	202700	202700	202700	202700	202700	202700	202700	202700	202700	202700	202700
50-26	Acorn Nut and Washer	202701	-	-	-	-	-	-	-	-	-	-	-	-	-	-	-
50-27	Screw	203232	203216	203216	203216	203216	203216	203216	203216	203246	203246	203246	203246	203246	203246	203246	203246
50-27-2	Screw for Seal Minder Cable	-	-	203216	203216	203216	203216	203216	203216	203216	203216	203216	203216	203216	203216	203216	203216
50-31E	Screw	202692	202692	202692	202692	202692	202692	202692	202692	202692	202692	202692	202692	202692	202692	202692	202692
50-32	Screw	-	203214	203214	203214	203214	203214	203214	203214	-	-	-	-	-	-	-	-
50-33	Screw	-	203214	203214	203214	203214	203214	203214	203214	203214	203214	203214	203214	-	-	-	-
50-34	Screw	-	203219	203219	203219	203219	203219	203219	203219	203219	203219	203219	203219	-	-	-	-
50-34-1	Screw for Handle w/ Cable Chain	-	-	-	-	-	-	-	-	-	-	-	-	203228	203228	203228	203228
50-34-2	Screw for Handle	-	-	-	-	-	-	-	-	-	-	-	-	203288	203288	203288	203288
50-34-3	Lock Washer	-	-	-	-	-	-	-	-	-	-	-	-	202902	202902	202902	202902
50-38E	Bolt - Discharge Elbow	-	-	-	-	-	-	-	-	-	-	-	-	203287	203287	203287	203287
50-38F	Bolt - Discharge Flange	-	-	-	-	-	-	-	-	-	-	-	-	203287	203287	203287	203287
	O-Ring Kit-Buna N	202623	202625	202628	202628	202628	202635	202635	202635	202637	202637	202637	202637	202639	202639	202639	202639

JX PRECISION CAST PARTS LIST

	Pump Model	JX400SS	JX750SS	JX1500SS	JX1500HSS	JX08SS	JX15SS	JX15HSS	JX22SS	JX22HSS	JX37SS	JX37HSS	JX55CSS	JX55CHSS	JX75CSS	JX75CHSS
Pos. No.	Part Description	Item #	Item #	Item #	Item #	Item #	Item #	Item #	Item #	Item #	Item #	Item #	Item #	Item #	Item #	Item #
01	Strainer with Bottom Plate	201965	201971	201971	201971	201971	201971	201971	201974	201974	201974	201974	201977	201977	201977	201977
02	Suction Cover	-	202027	202028	202027	202027	202028	202027	202010	202012	202010	202012	202034	202033	202034	202033
03	Impeller Nut	-	-	-	-	202894	202894	202894	202894	202894	202894	202894	202895	202895	202895	202895
04	Lock washer	-	-	-	-	202907	202907	202907	202907	202907	202907	202907	202904	202904	202904	202904
05	Impeller	202056	202060	202063	202065	202066	202068	202070	202071	202073	202075	202077	202081	202080	202085	202084
06	Impeller Key	-	-	-	-	202140	202140	202140	202140	202140	202140	202140	202141	202141	202141	202141
07	Pump Housing	202994	202164	202166	202164	202164	202166	202164	202168	202168	202168	202168	202171	202171	202171	202171
07-1	O-Ring (Kit Only)	Kit	Kit	Kit	Kit	Kit	Kit	Kit	Kit	Kit	Kit	Kit	Kit	Kit	Kit	Kit
08	Oil Chamber Cover	202208	202214	202214	202214	202214	202214	202214	202219	202219	202219	202219	202216	202216	202216	202216
08-1	O-Ring (Kit Only)	Kit	Kit	Kit	Kit	Kit	Kit	Kit	Kit	Kit	Kit	Kit	Kit	Kit	Kit	Kit
09	Lip Seal FKM	202230	202232	202232	202232	202232	202232	202232	202235	202235	202235	202235	203058	203058	203058	203058
09	Lip Seal Buna-N (Optional)	202229	203051	203051	203051	203051	203051	203051	202234	202234	202234	202234	203055	203055	203055	203055
09	Lip Seal EPDM (Optional)	203050											203056	203056	203056	203056
09A	Double Lip Seal FKM	-	-	-	-	-	-	-	-	-	-	-	202240	202240	202240	202240
09A	Double Lip Seal Buna-N (Optional)	-	-	-	-	-	-	-	-	-	-	-	202249	202249	202249	202249
09A	Double Lip Seal EPDM (Optional)	-	-	-	-	-	-	-	-	-	-	-	203060	203060	203060	203060
10	Shaft Sleeve	202258											202257	202257	202257	202257
12	Lip Seal for Lower Bearing	-	-	-	-	-	-	-	-	-	-	-	202236	202236	202236	202236
13	Mechanical Seal FKM**	202260	204240	204240	204240	204240	204240	204240	204243	204243	204243	204243	200304	200304	200304	200304
13	Mechanical Seal Buna-N	202259	200501	200501	200501	200501	200501	200501	200302	200302	200302	200302	200305	200305	200305	200305
14	Lower Ball Bearing	200493	200958	200958	200958	200958	200958	200958	200959	200959	200959	200959	200960	200960	200961	200961
14-1	Lower Ball Bearing	-	-	-	-	-	-	-	-	-	-	-	200960	200960	200961	200961
14-2	Lower Bearing Retainer Clip	-	202279	202279	202279	202279	202279	202279	202279	202279	202279	202279	202279	202279	202279	202279
15	Impeller Shim Kit	-	200481	200480	200480	200480	200480	200480	200480	200480	200480	200480	200479	200479	200479	200479
17	Rotor w/ Shaft 115/230V, 1PH	202303	203089	203093	203093	-	-	-	-	-	-	-	-	-	-	-
17	Rotor w/ Shaft, 3 PH	-	-	-	-	202308	202312	202312	202316	202316	202320	202320	202344	202344	202346	202346
18	Stator w/Casing, 115V, 1HP	200510	200513	-	-	-	-	-	-	-	-	-	-	-	-	-
18	Stator w/Casing, 230V, 1PH	200522	200571	200516	200516	-	-	-	-	-	-	-	-	-	-	-
18	Stator w/Casing, 208V, 3PH	-	-	-	-	200526	200530	200530	200534	200534	200538	200538	200667	200667	-	-
18	Stator w/Casing, 230/460V, 3PH	-	-	-	-	200548	200552	200552	200556	200556	200560	200560	200564	200564	200568	200568
18	Stator w/Casing, 575V, 3PH	-	-	-	-	200590	200594	200594	200598	200598	200602	200602	200607	200607	200611	200611
19	Governor Switch w/Switch Plate	202359	202360	202360	202360	-	-	-	-	-	-	-	-	-	-	-
20	Upper Ball Bearing	200957	200967	200967	200967	200967	200967	200967	200958	200958	200958	200958	200959	200959	200959	200959
20-1	O-Ring (Kit Only)	-	-	-	-	-	-	-	-	-	-	-	Kit	Kit	Kit	Kit
21A	Oil Chamber	200497	202197	202197	202197	202197	202197	202197	202198	202198	202198	202198	202179	202179	202170	202170
21A-1	O-Ring (Kit Only)	Kit	Kit	Kit	Kit	Kit	Kit	Kit	Kit	Kit	Kit	Kit	Kit	Kit	Kit	Kit
21B	Motor Cover	202365	202368	202368	202368	-	-	-	-	-	-	-	-	-	-	-
23	Overload 115V, 1PH	202380	202383	-	-	-	-	-	-	-	-	-	-	-	-	-
23	Overload 230V, 1PH	-	202395	202383	202383	-	-	-	-	-	-	-	-	-	-	-
23	Overload 208V, 3PH	-	-	-	-	202385	202388	202388	202390	202390	202392	202392	202394	202394	-	-
23	Overload 230V, 3PH	-	-	-	-	202385	202388	202388	202390	202390	202392	202392	202394	202394	202396	202396
23	Overload 460V, 3PH	-	-	-	-	202387	202386	202386	202389	202389	202391	202391	202393	202393	202394	202394
23	Overload 575V, 3PH	-	-	-	-	202399	202387	202387	202386	202386	202389	202389	202391	202391	202393	202393

24	Capacitor 115V	202415	202417	-	-	202818	-	-	-	-	-	-	-	-	-	-
24	Capacitor 230V	202416	202418	202420	202420	-	-	-	-	-	-	-	-	-	-	-
26	Pump Top Cover	203121	202434	202434	202434	202436	202436	202436	202438	202438	202438	202438	202440	202440	202440	202440
26-1	O-Ring (Kit Only)	Kit	Kit	Kit	Kit	Kit	Kit	Kit	Kit	Kit	Kit	Kit	Kit	Kit	Kit	Kit
27	Power Cable w/ Gland-115V, 1PH	204261	204262	-	-	-	-	-	-	-	-	-	-	-	-	-
27	Power Cable w/ Gland-230V, 1PH, No Plug	201685	201695	201691	201691	-	-	-	-	-	-	-	-	-	-	-
27	Power Cable w/ Gland- 3PH	-	-	-	-	201702	201702	201702	203443	203443	203445	203445	203447	203447	203447	203447
27-1	O-Ring (Kit Only)	Kit	Kit	Kit	Kit	Kit	Kit	Kit	Kit	Kit	Kit	Kit	Kit	Kit	Kit	Kit
27-2	Seal Minder Cable	-	201713	201716	201716	201713	201713	201713	201713	201713	201713	201713	201713	201713	201713	201713
27-2-1	O-Ring (Kit Only)	-	Kit	Kit	Kit	Kit	Kit	Kit	Kit	Kit	Kit	Kit	Kit	Kit	Kit	Kit
27-3	Oil Sensor Cap	-	201718	201718	201718	201718	201718	201718	201718	201718	201718	201718	201718	201718	201718	201718
31D	Seal Minder Probe	-	202408	202408	202408	202408	202408	202408	203999	203999	203999	203999	204000	204000	204000	204000
31E	Ground Wire w/Ring Term.	203145	203145	203145	203145	203145	203145	203145	203145	203145	203145	203145	203145	203145	203145	203145
32	Power Cord Line Clip / Strain Relief	203161	203166	203166	203166	203161	203161	203161	202504	202504	202499	202499	202499	202499	202499	202499
33	Seal Minder Cable Line Clip	-	203163	203163	203163	203163	203163	203163	203163	203163	203163	203163	203163	203163	203163	203163
34	Handle	202517	202517	202517	202517	202517	202517	202517	202517	202517	202517	202517	203171	203171	203171	203171
35	Holding Rods	202665	202682	202683	202683	202684	202685	202685	202686	202686	202687	202687	202673	202673	202674	202674
38	Discharge Nipple	202532	202532	202535	202532	202532	202535	202532	202535	202532	202535	202532	-	-	-	-
38E	Discharge Elbow	-	-	-	-	-	-	-	-	-	-	-	202561	202561	202561	202561
38E-1	Gasket Discharge Elbow FKM	-	-	-	-	-	-	-	-	-	-	-	203211	203211	203211	203211
38E-1	Gasket Discharge Elbow Buna-N (Optional)	-	-	-	-	-	-	-	-	-	-	-	203210	203210	203210	203210
38F	Discharge Flange	-	202563	202546	202563	202563	202546	202563	202546	202544	202546	202544	202540	202539	202540	202540
38F	Discharge Connection 4" NPT-F	-	-	-	-	-	-	-	202553	-	202553	-	-	-	-	-
38F-1	O-Ring - Discharge Flange FKM	-	202723	202724	202723	202723	202724	202723	202724	202724	202724	202724	203211	203211	203211	203211
38F-1	O-Ring - Discharge 4" NPT-F FKM	-	-	-	-	-	-	-	203328	-	203328	-	203210	203210	203210	203210
50-01	Screw	202694	203215	203215	203215	203215	203215	203215	203297	203297	203297	203297	203229	203229	203229	203229
50-02	Screw	-	203216	203216	203216	203216	203216	203216	203220	203220	203220	203220	203229	203229	203229	203229
50-07	Screw	203216	203296	203296	203296	203296	203296	203296	203296	203296	203296	203296	203229	203229	203229	203229
50-08	Screw	203215	203219	203219	203219	203219	203219	203219	203219	203219	203219	203219	203246	203246	203246	203246
50-11	Screw	203218	203218	203218	203218	203218	203218	203218	203218	203218	203218	203218	203218	203218	203218	203218
50-11-1	O-Ring (Kit Only)	Kit	Kit	Kit	Kit	Kit	Kit	Kit	Kit	Kit	Kit	Kit	Kit	Kit	Kit	Kit
50-12	Screw	203218	203218	203218	203218	203218	203218	203218	203218	203218	203218	203218	203218	203218	203218	203218
50-12-1	O-Ring (Kit Only)	Kit	Kit	Kit	Kit	Kit	Kit	Kit	Kit	Kit	Kit	Kit	Kit	Kit	Kit	Kit
50-14-2	Screw	-	203219	203219	203219	203219	203219	203219	203219	203219	203219	203219	203219	203219	203219	203219
50-19A	Screw	203215	-	-	-	-	-	-	-	-	-	-	-	-	-	-
50-19	Screw	202693	202693	202693	202693	-	-	-	-	-	-	-	-	-	-	-
50-22	Screw	202692	-	-	-	-	-	-	-	-	-	-	-	-	-	-
50-23	Screw	202693	202700	202700	202700	202700	202700	202700	202700	202700	202700	202700	202700	202700	202700	202700
50-27	Screw	202692	203295	203295	203295	203295	203295	203295	203246	203246	203246	203246	203246	203246	203246	203246
50-27-2	Screw for Seal Minder Cable	203216	203295	203295	203295	203295	203295	203295	203295	203295	203295	203295	203216	203216	203216	203216
50-31E	Screw	202692	202692	202692	202692	202692	202692	202692	202692	202692	202692	202692	202692	202692	202692	202692
50-32	Screw	203214	203214	203214	203214	203214	203214	203214	-	-	-	-	-	-	-	-
50-33	Screw	-	203214	203214	203214	203214	203214	203214	203214	203214	203214	203214	-	-	-	-
50-34	Screw	203219	203219	203219	203219	203219	203219	203219	203296	203296	203296	203296	-	-	-	-
50-34-1	Screw for Handle w/ Cable Chain	-	-	-	-	-	-	-	-	-	-	-	203228	203228	203228	203228
50-34-2	Screw for Handle	-	-	-	-	-	-	-	-	-	-	-	203288	203288	203288	203288
50-34-3	Lock Washer	-	-	-	-	-	-	-	-	-	-	-	202902	202902	202902	202902
50-38E	Bolt - Discharge Elbow	-	-	-	-	-	-	-	-	-	-	-	203287	203287	203287	203287
50-38F	Bolt - Discharge Flange	-	-	-	-	-	-	-	203253	203253	203253	203253	203287	203287	203287	203287
	O-Ring Kit-FKM	202626	202630	202630	202630	202647	202647	202647	202642	202642	202642	202642	202645	202645	202645	202645



SINGLE PHASE WIRING DIAGRAM 115V & 230V W/O GOVERNOR SWITCH

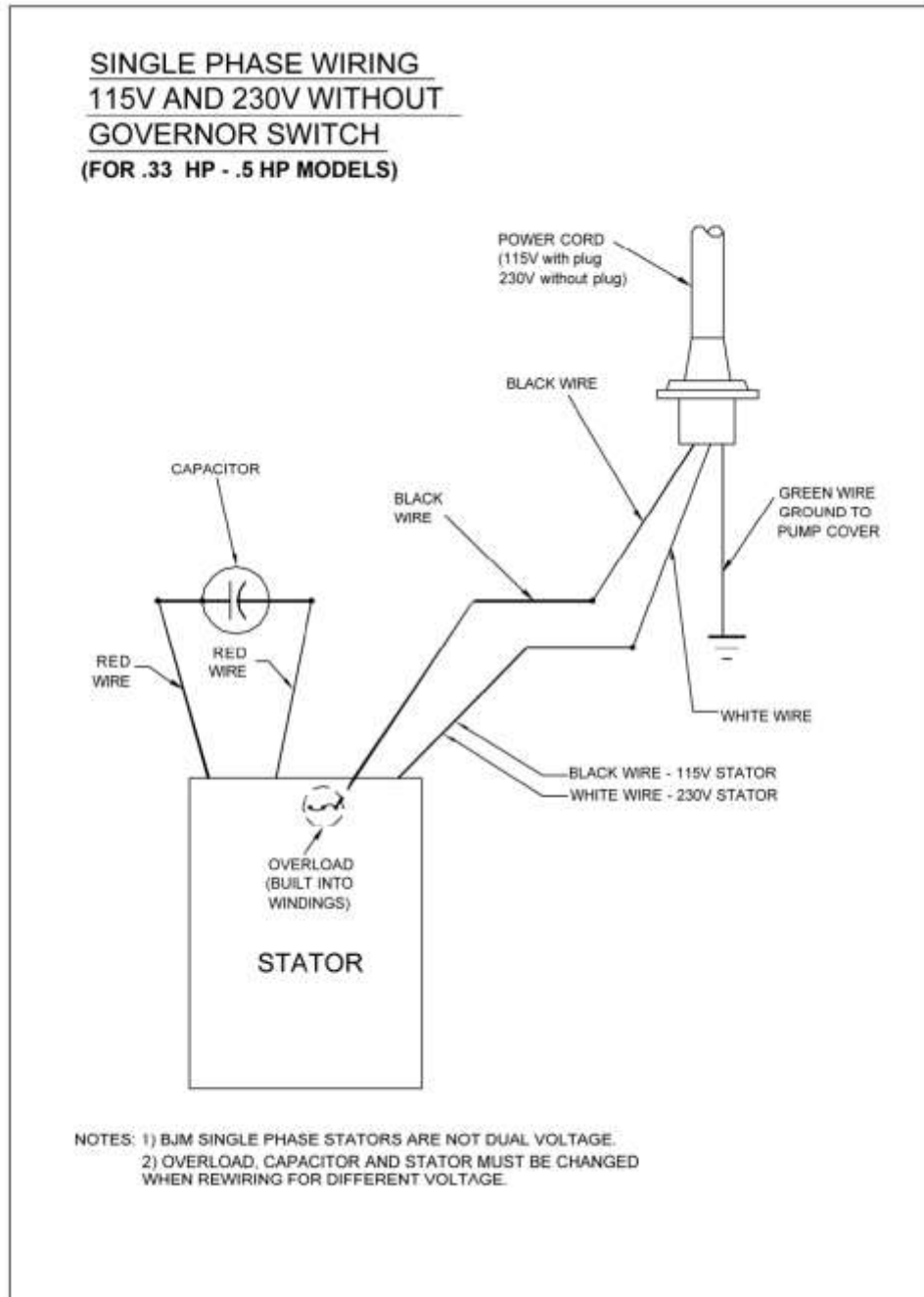

MODELS J400, JX400SS



SINGLE PHASE WIRING
115V AND 230V WITH
GOVERNOR SWITCH
(FOR 1 HP - 2.5 HP MODELS)

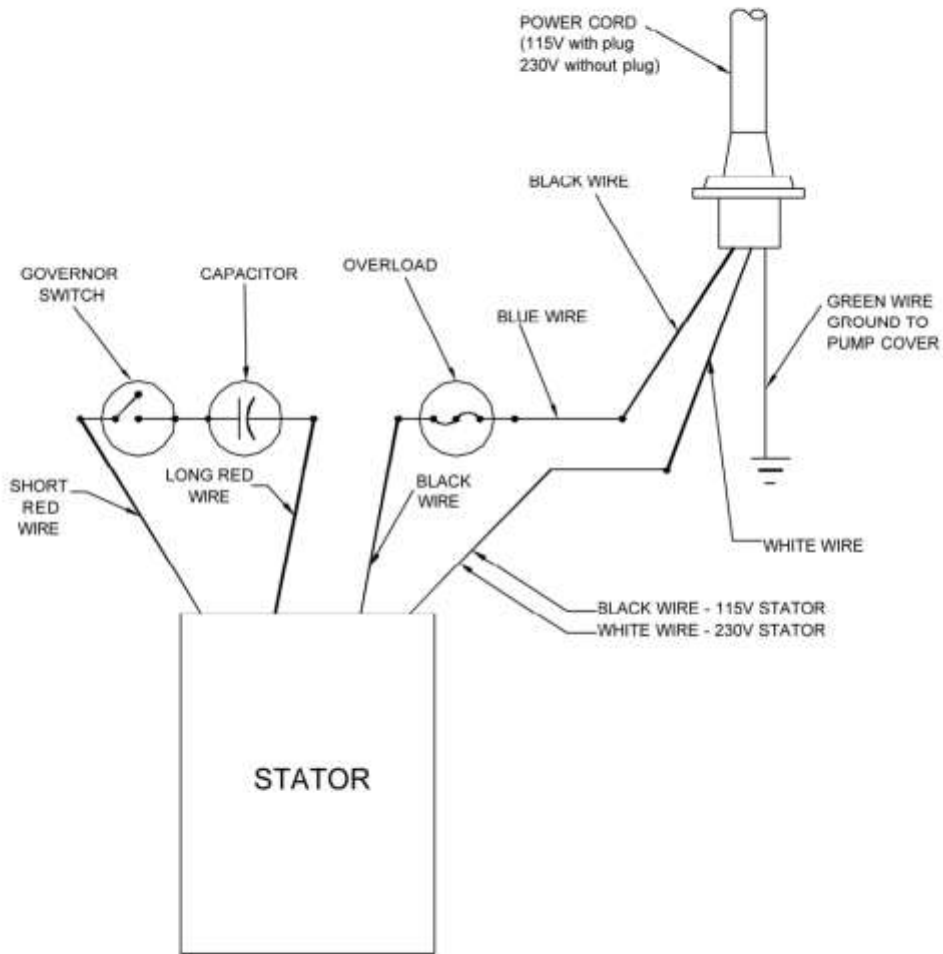

- NOTES: 1) BJM SINGLE PHASE STATORS ARE NOT DUAL VOLTAGE.
2) OVERLOAD, CAPACITOR AND STATOR MUST BE CHANGED WHEN REWIRING FOR DIFFERENT VOLTAGE.

MODELS J750, JX750, J1500, JX1500H, JX1500HSS

THREE PHASE WIRING DIAGRAM

208V

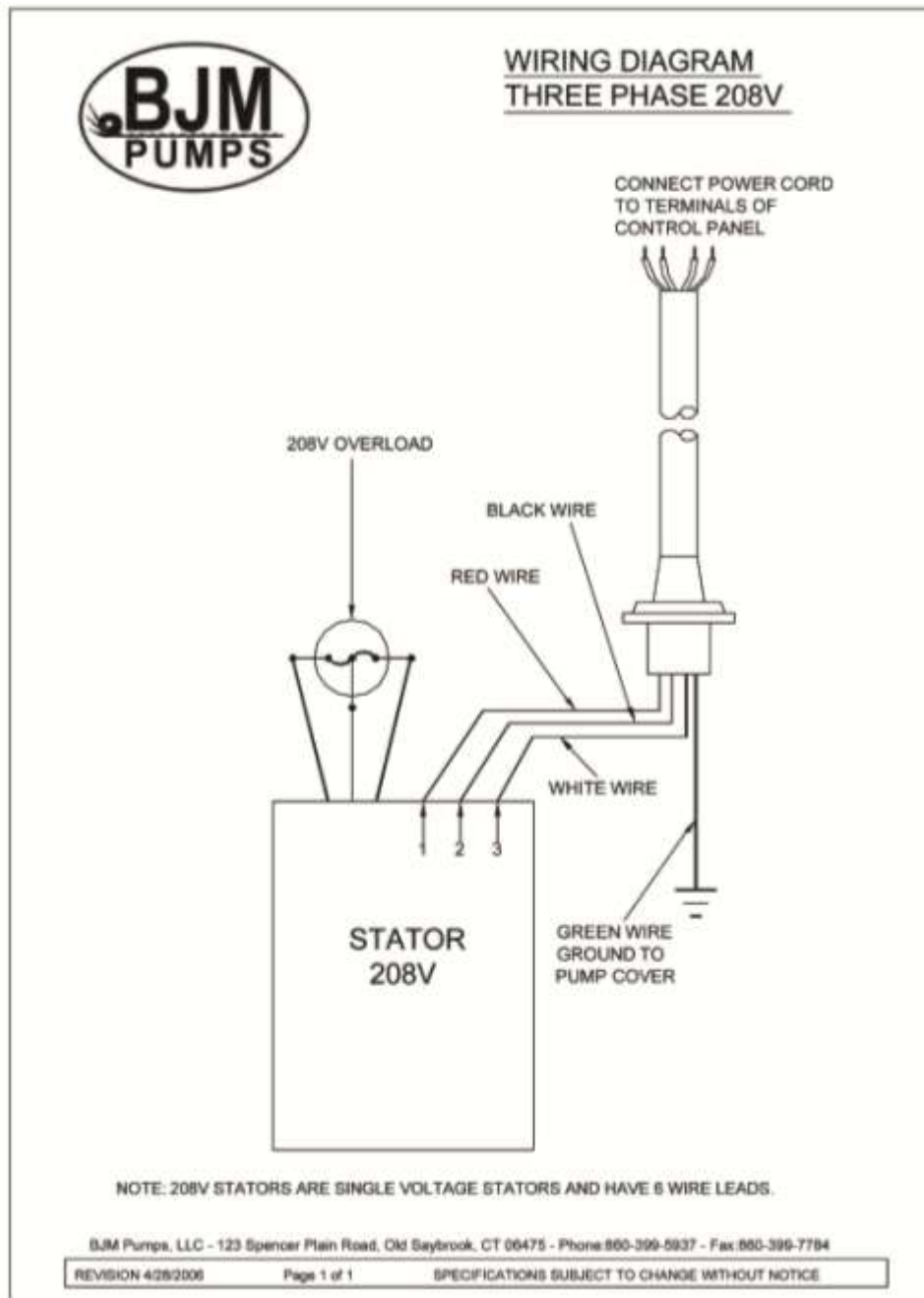

MODELS J08, JX08SS, J15, JX15SS, J15H, JX15HSS, J22, JX22SS, J22H, JX22HSS, J37, JX37SS, J37H, J37HSS, J55C, J55CSS, J55CH, J55CHSS, J75C, JX75CSS, J75CH, J75CHSS

230V

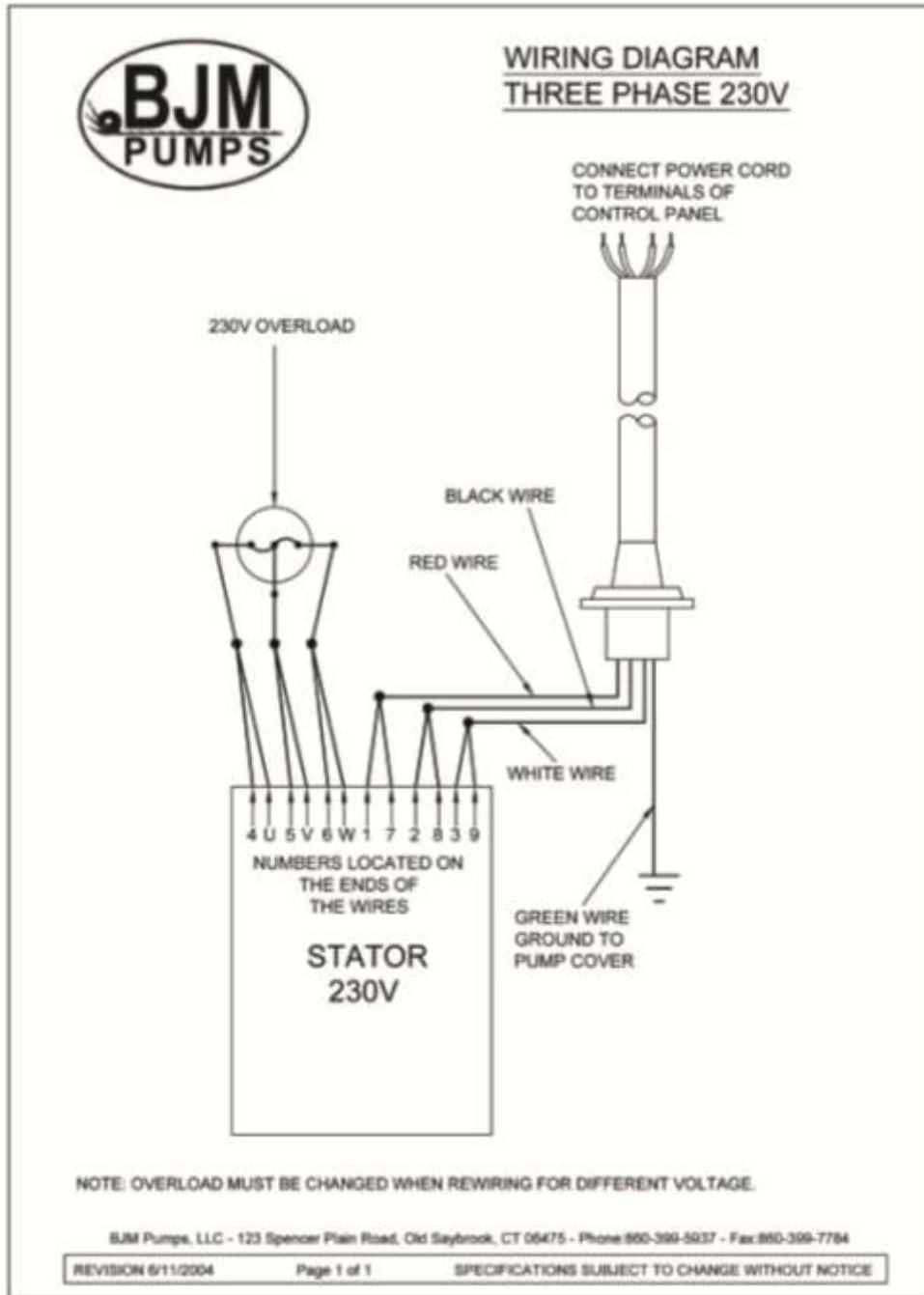

MODELS J08, JX08SS, J15, JX15SS, J15H, JX15HSS, J22, JX22SS, J22H, JX22HSS, J37, JX37SS, J37H, J37HSS, J55C, J55CSS, J55CH, J55CHSS, J75C, JX75CSS, J75CH, J75CHSS

460V

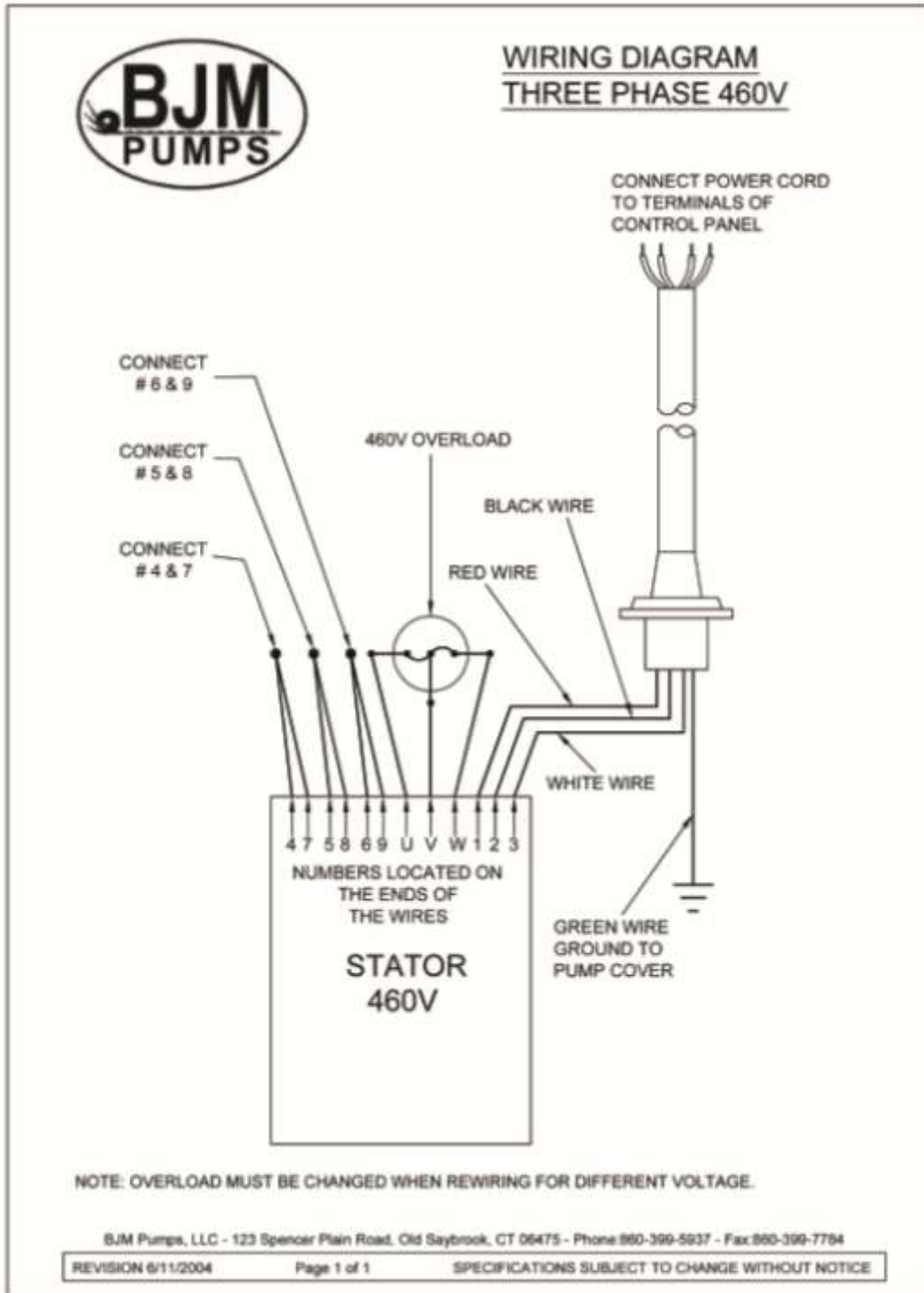

MODELS J08, JX08SS, J15, JX15SS, J15H, JX15HSS, J22, JX22SS, J22H, JX22HSS, J37, JX37SS, J37H, J37HSS, J55C, J55CSS, J55CH, J55CHSS, J75C, JX75CSS, J75CH, J75CHSS

575V

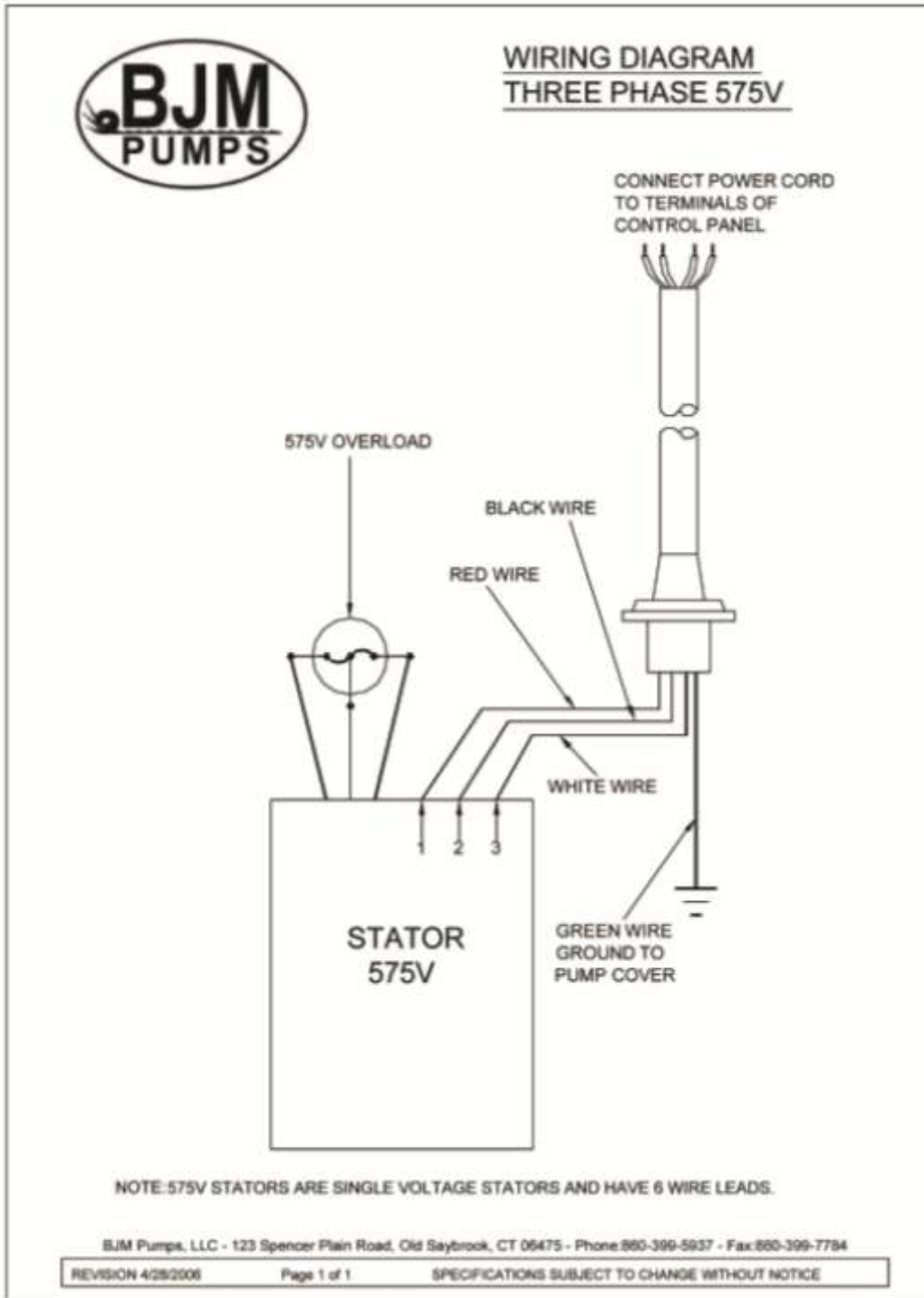

MODELS J08, JX08SS, J15, JX15SS, J15H, JX15HSS, J22, JX22SS, J22H, JX22HSS, J37, JX37SS, J37H, J37HSS, J55C, J55CSS, J55CH, J55CHSS, J75C, JX75CSS, J75CH, J75CHSS



SEAL MINDER®



Seal Minder® INFORMATION

Seal Minder:

Also known as a seal failure circuit (or moisture detection circuit) is designed to inform the pump operator that there is moisture within the oil chamber. This early warning can allow the operator to schedule repair & inspection on the pump. The **Seal Minder** is a sensor probe inside the oil chamber. (The oil chamber houses the mechanical seals that are cooled & lubricated by oil). The **Seal Minder**, when properly connected to a control panel, can help indicate seal failure. The **Seal Minder** cord requires a seal fail circuit in control panel for warning signal.

The open end of the **Seal Minder** circuit cord should be connected to a control panel with an optional seal failure alarm relay circuit or a standalone **Seal Minder** Panel manufacturers can incorporate the **Seal Minder** cord option. BJM Pumps, LLC has a stand alone, **Seal Minder** panel for both simplex (P/N MSP8350A) and duplex (P/N MSP8350B) systems. For more information contact BJM Pumps, LLC or visit us online at www.bjmpumps.com

The **Seal Minder** cord has two leads, black and white. Note that the power cable is much larger and has 3 to five leads, depending on the model. Inside the pump, the black lead is connected to the casing ground, and the white lead is connected to the seal probe that is suspended into the oil chamber fluid. These leads need to be properly connected to the seal failure alarm relay circuit. Most controls that have provided for this option have a connection terminal point that is clearly marked for these connections. Consult the control panel manual for proper connection instructions.

Although highly recommended, the pump does not need a control box with seal fail relay or stand alone seal panel to operate.

If the operator does not use the Seal Minder:

1. The recommended procedure is to take the **Seal Minder** cord off the pump and seal with a **Seal Minder** cap (P/N M02738) and gasket (P/N M05121 for Buna, P/N M05121V for FKM). This should be done by an authorized BJM Pumps service center or distributor as not to void warranty Detailed instruction sheet available for this procedure.
2. Alternate method of securing **Seal Minder** cable if not being used: Tape the **Seal Minder** cord to the power cord. Make sure that the cords are taped together in an even run, at about 2' to 3' apart. Use electrical tape to tape off the end of the **Seal Minder** cable (Do not connect to power source). The taped leads should be kept dry and out of the liquid. (See next page for detailed drawing.

Seal Minder is a registered trademark of BJM Pumps, LLC

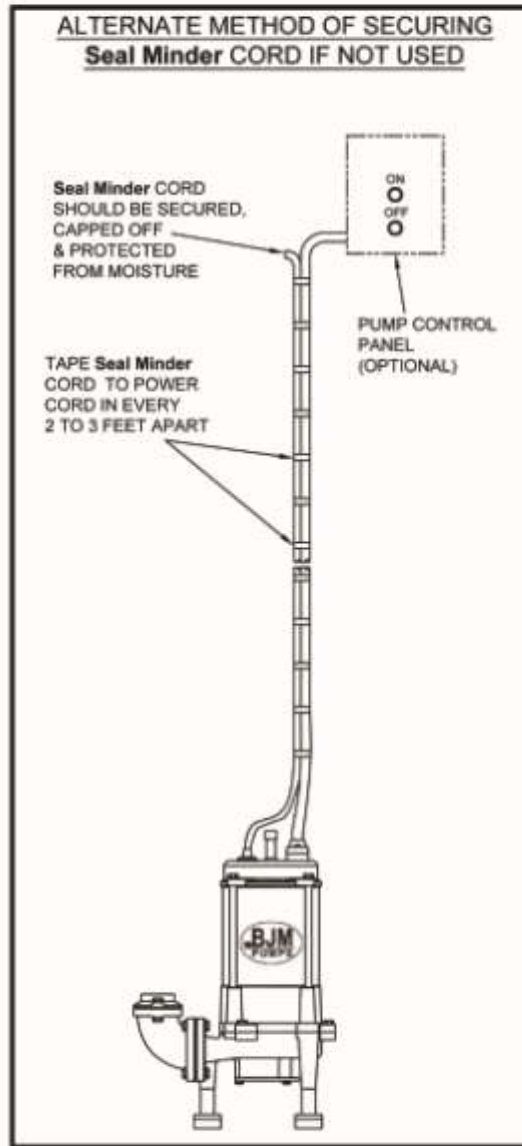
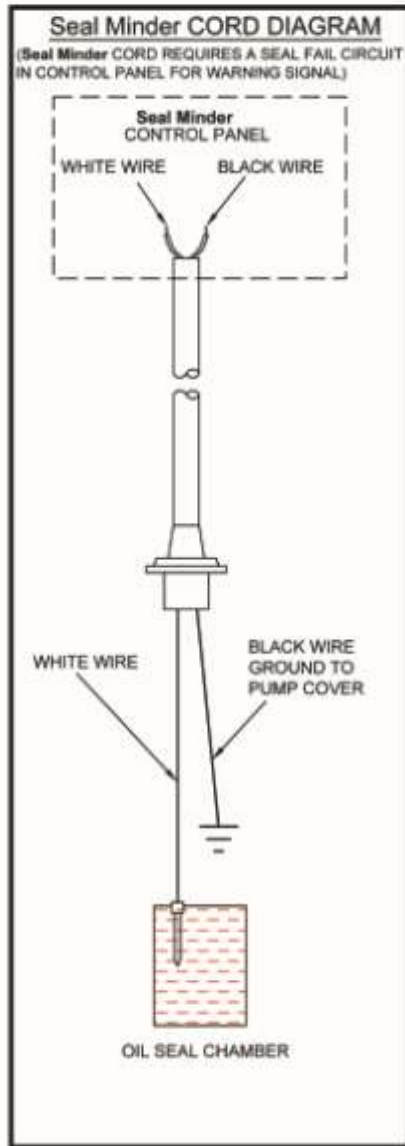

SPECIFICATIONS SUBJECT TO CHANGE WITHOUT NOTICE.

BJM Pumps, LLC - 123 SPENCER PLAIN ROAD, OLD SAYBROOK, CT 06475 - PHONE: 860-399-5937 - FAX: 860-399-7784
BJM Pumps® & Seal Minder® is a registered trademark of BJM Pumps, LLC. Copyright 2006-2009. All rights reserved.

Seal Minder™ is an optional accessory on the J & JX Series. (Not available on the J400 or JX400)



BJM PUMPS, LLC
123 Spencer Plain Road
Old Saybrook, CT 06475, U.S.A.

WARRANTY AND LIMITATION OF LIABILITY

Unless otherwise expressly authorized in writing, specifying a longer or shorter period, BJM Pumps, LLC warrants for a period of eighteen (18) months from the date of shipment from the Point of Shipment, or one (1) year from the date of installation, whichever occurs first, that all products or parts thereof furnished by BJM Pumps, LLC under the brand name **BJM Pumps**, hereinafter referred to as the "Product" are free from defects in materials and workmanship and conform to the applicable specification.

BJM Pumps, LLC's liability for any breach of this warranty shall be limited solely to replacement or repair, at the sole option of BJM Pumps, LLC, of any part or parts of the Product found to be defective during the warranty period, provided the Product is properly installed and is being used as originally intended. Any breach of this warranty must be reported to BJM Pumps, LLC or BJM Pumps, LLC's authorized service representative within the aforementioned warranty period, and defective Product or parts thereof must be shipped to BJM Pumps, LLC or BJM Pumps, LLC's authorized representative, transportation charges prepaid. Any cost associated with removal or installation of a defective Product or part is excluded.

IT IS EXPRESSLY AGREED THAT THIS SHALL BE THE SOLE AND EXCLUSIVE REMEDY OF BJM PUMPS, LLC'S DISTRIBUTORS AND CUSTOMERS. UNDER NO CIRCUMSTANCES SHALL BJM PUMPS, LLC BE LIABLE FOR ANY COSTS, LOSS, EXPENSE, DAMAGES, SPECIAL DAMAGES, INCIDENTAL DAMAGES OR CONSEQUENTIAL DAMAGES ARISING DIRECTLY OR INDIRECTLY FROM THE DESIGN, MANUFACTURE, SALE, USE OR REPAIR OF THE PRODUCT, WHETHER BASED ON WARRANTY, CONTRACT, NEGLIGENCE, OR STRICT LIABILITY. IN NO EVENT WILL LIABILITY EXCEED THE PURCHASE PRICE OF THE PRODUCT.

THE WARRANTY AND LIMITS OF LIABILITY CONTAINED HEREIN ARE IN LIEU OF ALL OTHER WARRANTIES AND LIABILITIES, EXPRESSED OR IMPLIED. ALL IMPLIED WARRANTIES OF MERCHANTABILITY AND FITNESS FOR A PARTICULAR PURPOSE ARE HEREBY DISCLAIMED BY BJM PUMPS, LLC AND EXCLUDED FROM THIS WARRANTY.

BJM Pumps, LLC neither assumes, nor authorizes any person to assume for it, any other warranty obligation in connection with the sale of the Product. This warranty shall not apply to any Product or parts of Product which have (a) been repaired or altered outside of BJM Pumps, LLC's facilities unless such repair was authorized in advance by BJM Pumps, LLC or by its authorized representative; or (b) have been subject to misuse, negligence or accident; or (c) have been used in a manner contrary to BJM Pumps, LLC's instruction.

In any case of products not manufactured and sold under the BJM Pumps, LLC brand name, there is no warranty from BJM Pumps, LLC; however BJM Pumps, LLC will extend any warranty received from BJM Pumps, LLC's supplier of such products.

START-UP REPORT FORM

START-UP REPORT FORM

This form is designed to record the initial installation, and to serve as a guide for troubleshooting at a later date (if needed).

BJM Pumps, LLC
123 Spencer Plain Road
Old Saybrook, CT. 06475

Pump Owner's Name			
Location of Installation			
Person in Charge			Phone()
Purchased From			
Model		Serial No	
Voltage	Phase	Hertz	HP
Does impeller turn freely by hand?	<input type="checkbox"/> Yes <input type="checkbox"/> No		
Condition of Equipment	<input type="checkbox"/> New <input type="checkbox"/> Good <input type="checkbox"/> Fair <input type="checkbox"/> Poor		
Condition of Cable Jacket	<input type="checkbox"/> New <input type="checkbox"/> Good <input type="checkbox"/> Fair <input type="checkbox"/> Poor		
Rotation: Direction of Impeller Rotation (Use C/W for clockwise, CC/W for counterclockwise):			

Method used to check rotation (viewed from bottom) _____			
Resistance of cable and Pump Motor (measured at pump control)			
Red-Black_____ ohms	Red-White_____ ohms	White-Black____ohms	
Resistance of ground circuit between control panel and outside of pumps			
_____ Ohms			
MEG OHM CHECK OF INSULATION			
Red to ground_____ White to ground_____ Black to ground_____			
Condition of location at start-up	<input type="checkbox"/> Dry <input type="checkbox"/> Wet <input type="checkbox"/> Muddy		
Was equipment stored	<input type="checkbox"/> Yes <input type="checkbox"/> No.		
If YES, length of storage:			
Liquid being pump			
Debris in bottom of station?	<input type="checkbox"/> Yes <input type="checkbox"/> No		
Was debris removed in your	<input type="checkbox"/> Yes <input type="checkbox"/> No		

START-UP REPORT FORM

presence?		
Are guide rails exactly vertical?	<input type="checkbox"/> Yes	<input type="checkbox"/> No
Is base elbow installed level?	<input type="checkbox"/> Yes	<input type="checkbox"/> No
Liquid level controls: Model _____		
Is control installed away from turbulence?	<input type="checkbox"/> Yes	<input type="checkbox"/> No
Operation Check		
Tip lowest float (stop float), all pumps should remain off. Tip second float (and stop float), one pump comes on. Tip third float (and stop float), both pumps on (alarm on simplex). Tip fourth float (and stop float), high level alarm on (omit on simplex).		
If not on levels controls, describe type of controls		
Does liquid level ever drop below volute top?	<input type="checkbox"/> Yes	<input type="checkbox"/> No
Control Panel MFG & model no.		
Number of pumps operated by control panel		
NOTE: At no time should hole be made in top of control panel, unless proper sealing devices are utilized.		
Short Circuit protection:	Type:	
Number and size of short circuit device(s)	Amp rating:	
Overload type:	Size:	Amp rating:
Do protective devices comply with pump motor amp rating?	<input type="checkbox"/> Yes	<input type="checkbox"/> No
Are all pump connections tight?	<input type="checkbox"/> Yes	<input type="checkbox"/> No
Is the interior of the panel dry?	<input type="checkbox"/> Yes	<input type="checkbox"/> No If No, correct moisture problem.
Electrical readings		
SINGLE PHASE		
Voltage supply at panel line connection, pump off	L1	L2
Voltage supply at panel line connection, pump on	L1	L2
Amperage load connection, pump on	L1	L2
THREE PHASE		
Voltage supply at panel line connection, pump off		
L1-L2	L2-L3	L3-L1

START-UP REPORT FORM

Voltage supply at panel line connection, pump on		
L1-L2	L2-L3	L3-L1
Amperage load connection, pump on		
L1	L2	L3
FINAL CHECK		
Is pump secured properly?	<input type="checkbox"/> Yes <input type="checkbox"/> No	
Was pump checked for leaks?	<input type="checkbox"/> Yes <input type="checkbox"/> No	
Do check valves operate properly?	<input type="checkbox"/> Yes <input type="checkbox"/> No	
Flow: Does station appear to operate at proper rate?	<input type="checkbox"/> Yes <input type="checkbox"/> No	
Noise level:	Acceptable <input type="checkbox"/>	Unacceptable <input type="checkbox"/>
Comments:		
Describe and equipment difficulties during start-up		
Installed by: Company: _____ Person: _____ Date: _____		
Maintained by: Company: _____ Person: _____		
Date and time of start-up _____ Present at start-up: () Engineer's name _____ () Contractor's name _____ () Operator's name _____ () others _____		

BJM Pumps, LLC
123 Spencer Plain Road • PO Box 1138 • Old Saybrook, CT 06475, USA
• Phone: (860) 399-5937 • Fax: (860) 399-7784



3/19/2014
0814
Supersedes
0813

TECHNICAL DATA
MODEL JX750SS
BJM SUBMERSIBLE PUMP - 316 SS
GENERAL DATA



MAX. FLOW: GPM (L/min)	91 GPM (344 L/min)
MAX. HEAD: ft (m)	50' (15.2 m)
MAX. SUBMERSION DEPTH: ft (m)	65' (20m) or limited to length of power cord, Consult factory for deeper depths
PUMP TYPE	SUMP, SIDE DISCHARGE
MINIMUM SUBMERSION DEPTH: in(mm)	9.5" (241 mm)
SOLID SIZE: in (mm)	3/16" (4.7 mm)
STRAINER OPENING	0.5625"x0.25" (14.3x6.3 mm) slot
IMPELLER DIAMETER: in (mm)	4.33" (110 mm)
DISCHARGE SIZE	2" NPT-MALE
PUMP WEIGHT, without cable: lbs (kg)	55 lbs (25 kg)
SHIPPING WEIGHT: lbs (kg)	66 lbs (30 kg)

CONSTRUCTION / MATERIAL DATA

MECHANICAL SEAL - UPPER	CARBON/CERAMIC
MECHANICAL SEAL - LOWER	SILICON CARBIDE/SILICON CARBIDE
MOTOR CASING	316 SS
PUMP VOLUTE	316 SS
IMPELLER- MULTI VANE	316 SS
STRAINER	316 SS
LIPSEAL & O-RINGS	VITON
ROTOR SHAFT	316 SS
EXTERNAL HARDWARE	316 SS
QTY. OIL IN SEAL CHAMBER	10.1 U.S. FL. OZ. (300 C.C.)
QTY. OIL IN MOTOR STATOR	No oil in motor stator (After ser# 42401). 13.5 U.S. FL. OZ. (400 C.C.) (Before ser# 42401).
BALL BEARING: PERM. LUBE. UPPER	6203
BALL BEARING: PERM. LUBE. LOWER	6304

ELECTRICAL / MOTOR DATA

MOTOR: TYPE, RATING HP	SUBMERSIBLE, 1 (CONTINUOUS DUTY ³)	
MOTOR RPM	3450	
MOTOR INSULATION CLASS	F	
MOTOR SERVICE FACTOR	1.1	
VOLTAGE ¹ - 1 PH, 60 Hz	115V	230V
CURRENT F.L.A.	14	7
LOCKED ROTOR CURRENT (LRA)	70	35
MOTOR PROTECTION	THERMAL & AMP. OVERLOAD	
POWER CORD: GAGE; LENGTH	A.W.G. 14/3; 33' (10 m), STOW	
MAXIMUM LIQUID TEMPERATURE	104°F (40°C)	
SEAL LEAK DETECTOR ² (OPTIONAL)	Seal Minder®; MOISTURE SENSING PROBE	

1- Available in other voltages (and in 50 Hz).

2- Requires a seal fail circuit in control panel for warning signal.

3 - NOTE: STAINLESS STEEL PUMPS **MAY NOT BE SUITABLE** FOR CONTINUOUS DUTY IN ALL APPLICATIONS. PLEASE CONSULT WITH BJM PUMPS. MAY BE NECESSARY TO OFFER 'F' SERIES HIGH TEMPERATURE PUMPS WHEN CONSIDERING CONTINUOUS DUTY OPERATION.

©2004 - 2014 BJM Pumps, LLC. All rights reserved.

123 Spencer Plain Road
Old Saybrook, CT. 06475, USA
(860)399-5937 - (877) BJM-PUMP - Fax: (860)399-7784

REFER TO REVERSE SIDE FOR PUMP PERFORMANCE CURVES
SPECIFICATIONS SUBJECT TO CHANGE WITHOUT NOTICE

Seal Minder is a registered trademark of BJM Pumps, LLC. All rights reserved.



MODEL: JX750SS

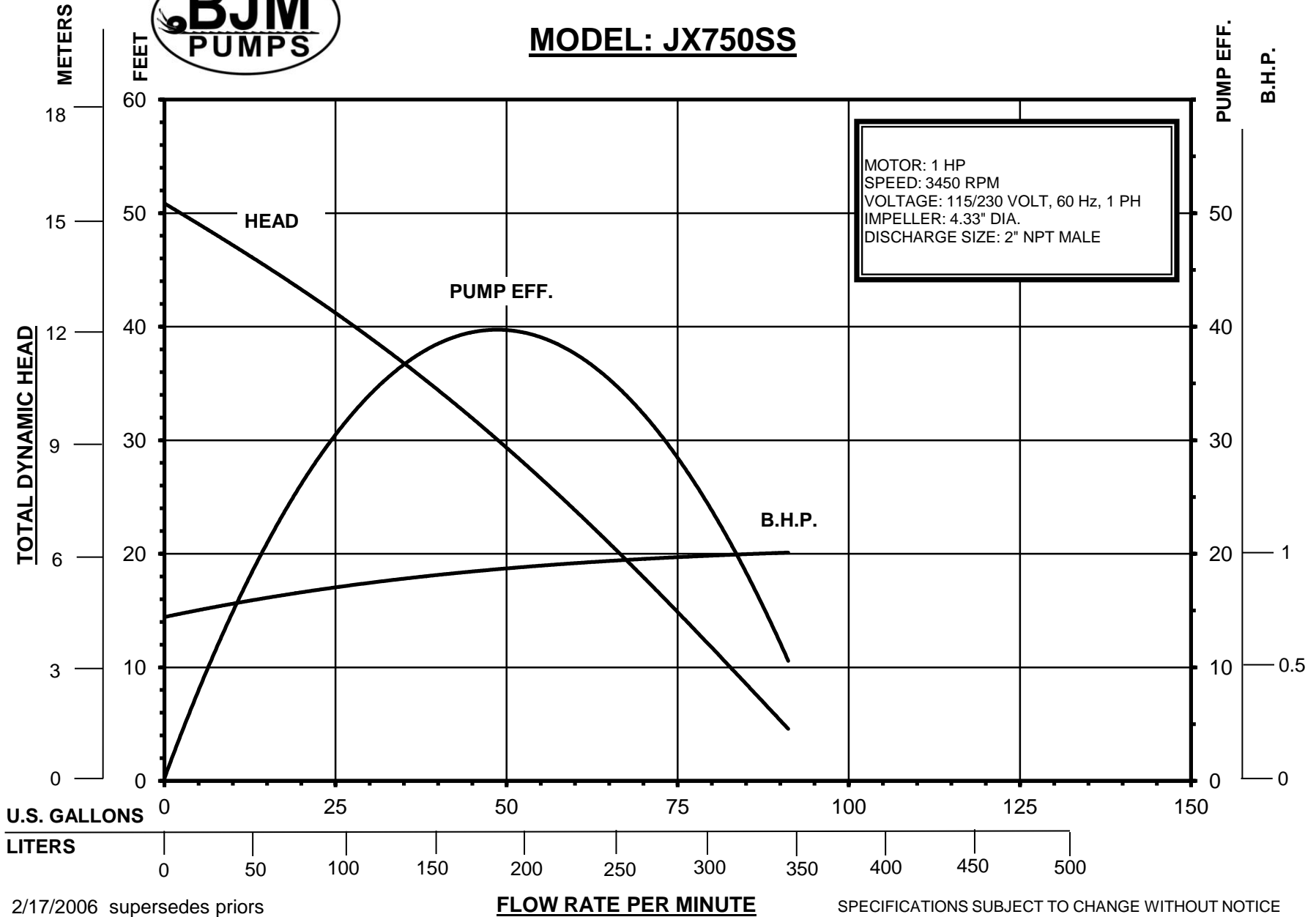

2/17/2006 supersedes priors

SPECIFICATIONS SUBJECT TO CHANGE WITHOUT NOTICE