



INSTALLATION, OPERATION & MAINTENANCE MANUAL

SV SERIES SIDE DISCHARGE Electric Submersible Pumps

**Single Phase
115V & 230V
Three Phase
208V, 230V, 460V & 575V**

CAST IRON

SINGLE PHASE

SV400
SV750
SV750C
SV1500

THREE PHASE

SV08
SV08C
SV15
SV22
SV37
SV55
SV75

Read this manual carefully before installing, operating or servicing these pump models. Observe all safety information. Failure to comply with instructions may result in personal injury and/or property damage. Please retain these instructions.

TABLE OF CONTENTS

INTRODUCTION.....	4
SAFETY	5
INSPECTION	6
PRE-INSTALLATION INSPECTION	6
OIL FILL QUANTITY/TYPE	6
PUMP INSTALLATION	7
POSITIONING THE PUMP	7
PUMP ROTATION	8
PUMP OPERATION.....	9
TYPICAL MANUAL DEWATERING INSTALLATION.....	9
MANUAL OPERATION	9
STOPPING.....	10
TYPICAL AUTOMATIC DEWATERING INSTALLATION	11
AUTOMATIC OPERATION	11
STOPPING.....	12
INTENDED METHODS OF CONNECTION.....	12
SINGLE PHASE WIRING INSTRUCTIONS.....	12
THREE PHASE WIRING INSTRUCTIONS.....	13
TROUBLE SHOOTING	15
PUMP WILL NOT RUN	15
PUMP RUNS BUT DOES NOT DELIVER RATED CAPACITY.....	15
SERVICING YOUR SUBMERSIBLE PUMP.....	15
MAINTAINING YOUR PUMP	15
CHANGING SEAL OIL	16
EXPLODED VIEW OF SV400.....	17
EXPLODED VIEW OF SV750.....	18
EXPLODED VIEW OF SV750C	19
EXPLODED VIEW OF SV1500.....	20
EXPLODED VIEW OF SV08.....	21
EXPLODED VIEW OF SV08C	22
EXPLODED VIEW OF SV15.....	23
EXPLODED VIEW OF SV22, SV37	24
EXPLODED VIEW OF SV55, SV75.....	25
SV SERIES PARTS LIST.....	26
SINGLE PHASE WIRING DIAGRAM 115V & 230V W/GOVERNOR SWITCH.....	28
MODELS SV400, SV750, SV750C, SV1500	28
THREE PHASE WIRING DIAGRAMS	29
208V.....	29
MODELS SV08, SV08C, SV15, SV22, SV37, SV55	29
230V.....	30
MODELS SV08, SV08C, SV15, SV22, SV37, SV55, SV75.....	30
460V.....	31
MODELS SV08, SV08C, SV15, SV22, SV37, SV55, SV75.....	31
575V.....	32
MODELS SV08, SV08C, SV15, SV22, SV37, SV55, SV75.....	32
SEAL MINDER.....	33
WARRANTY AND LIMITATION OF LIABILITY	35
START-UP REPORT FORM.....	36
NOTES:.....	39



INTRODUCTION

This Installation, Operation and Maintenance manual provides important information on safety and the proper inspection, disassembly, reassembly and testing of the BJM Pumps SV Series submersible pump. This manual also contains information to optimize performance and longevity of your BJM submersible pump.

The submersible SV Series pumps are designed to pump municipal and industrial wastewater. The SV Series pumps are not explosion-proof. They are not designed to pump volatile or flammable liquids.

Note: Consult chemical resistance chart for compatibility between pump materials and liquid before operating pump.

If you have any questions regarding the inspection, disassembly, reassembly or testing please contact your BJM Pumps distributor, or BJM Pumps, LLC.

BJM Pumps, LLC
123 Spencer Plain Rd
Old Saybrook, CT 06475, USA

Phone: 877-256-7867
Phone: 860-399-5937
Fax: 860-399-7784

For assistance with your electric power source, please contact a certified electrician.

Please pay attention to the following alert notifications. They are used to notify operators and maintenance personnel to pay special attention to procedures, to avoid causing damage to the equipment, and to avoid situations that could be dangerous to personnel.

NOTE: Instructions to aid in installation, operation, and maintenance or which clarify a procedure.

⚠ DANGER

Immediate hazards that WILL result in severe personal injury or death. These instructions describe the procedure required and the injury which will result from failure to follow the procedure.

⚠ WARNING

Hazards or unsafe practices that COULD result in severe personal injury or death. These instructions describe the procedure required, and the injury which could result from failure to follow the procedure.

⚠ CAUTION

Hazards or unsafe practices which COULD result in personal injury or product or property damage. These instructions describe the procedure required and the possible damage which could result from failure to follow the procedure.



SAFETY

Pump installations are seldom identical. Each installation and application can vary due to many different factors. It is the owner/service mechanics responsibility to repair, service, and test to ensure that the pump integrity is not compromised according to this manual.

⚠ WARNING

Risk of electric shock – this pump has not been investigated for use in swimming pool areas.

⚠ DANGER

Do not pump flammable, inflammable or volatile liquids. Death or serious injury will result.

⚠ WARNING

Before attempting to open or service the pump:

- 1) Familiarize yourself with this manual.
- 2) Unplug or disconnect the pump power cable to ensure that the pump will remain inoperative.
- 3) Allow the pump to cool if overheated.

⚠ WARNING

Do not operate the pump with a worn or damaged electric power cable. Death or serious injury could occur.

⚠ WARNING

Never attempt to alter the length or repair any power cable with a splice. The pump motor and pump motor and cable must be completely waterproof. Damage to the pump or personal injury may result from alterations.

⚠ WARNING

After the pump has been installed, make sure that the pump and all piping are secure before operation.

⚠ WARNING

Do not lift the pump by the power cable piping or discharge hose. Attach proper lifting equipment to the lifting handle (or lifting rings) fitted to the pump. Do not suspend the pump by the power cable.

⚠ WARNING

Obtain the services of a qualified electrician to troubleshoot, test and/or service the electrical components of this pump.

⚠ CAUTION

Pumps and related equipment must be installed and operated according to all national, local and industry standards.



INSPECTION

Review all safety information before servicing pump.

The following are recommended installation practices/procedures for the pump. If there are questions in regards to your specific application, contact your local BJM Pumps distributor or BJM Pumps, LLC.

PRE-INSTALLATION INSPECTION

- 1) Check the pump for damage that may have occurred during shipment.
- 2) Inspect the pump for any cracks, dents, damaged threads, etc.
- 3) Check power cable (and seal minder cable, if installed) for any cuts or damage.
- 4) Check for, and tighten any hardware that appears loose.
- 5) Carefully read all tags, decals and markings on the pump.
- 6) **Important:** Always verify that the pump nameplate, amps, voltage, phase, and HP ratings match your control panel and power supply.

Warranty does not cover damage caused by connecting pumps and controls to an incorrect power source (voltage/phase supply). Record the model numbers and serial numbers from the pumps and control panel on the front of this instruction manual for future reference. Give it to the owner or affix it to the control panel when finished with the installation.

If anything appears to be abnormal, contact your BJM Pumps distributor or BJM Pumps, LLC. If damaged, the pump may need to be repaired before use. Do not install or use the pump until appropriate action has been taken.

Lubrication:

No additional lubrication is necessary. The shaft seal and bearings are fully lubricated from the factory. Seal oil should be checked once per year. See table below.

OIL FILL QUANTITY/TYPE

Model	Oil in seal chamber		
	U.S. fl. oz.	cc.	Type of oil
SV250	5.1	150	ISO 32 NSF Food Grade Mineral Oil
SV400	5.1	150	ISO 32 NSF Food Grade Mineral Oil
SV750	9.3	275	ISO 32 NSF Food Grade Mineral Oil
SV750C	9.3	275	ISO 32 NSF Food Grade Mineral Oil



SV1500	9.3	275	ISO 32 NSF Food Grade Mineral Oil
SV08	9.3	275	ISO 32 NSF Food Grade Mineral Oil
SV08C	9.3	275	ISO 32 NSF Food Grade Mineral Oil
SV15	9.3	275	ISO 32 NSF Food Grade Mineral Oil
SV22	3.4	100	ISO 32 NSF Food Grade Mineral Oil
SV37	3.4	100	ISO 32 NSF Food Grade Mineral Oil
SV55	27	800	ISO 32 NSF Food Grade Mineral Oil
SV75	27	800	ISO 32 NSF Food Grade Mineral Oil

Note: EPDM seals will use Propylene glycol instead of ISO 32 NSF Food Grade Mineral Oil.

PUMP INSTALLATION

SV Series pumps have been evaluated for use with water or water based solutions. Please contact the manufacturer for additional information.



WARNING Risk of electric shock. Pump models; SV400, SV750 (115v) are supplied with a grounding conductor and grounding-type attachment plug. 230V single phase pumps and all three phase pumps do not come with electric plug connectors. To reduce the risk of electric shock, be certain that it is connected only to a properly grounded, grounding-type receptacle.

Lifting:

Attach a rope or lifting chain (not included) to the handle (or lifting rings) on the top of the pump.



CAUTION Do not lift the pump by the power cable or discharge hose/piping. Proper lifting equipment (rope/chain) must be used.

POSITIONING THE PUMP

BJM Pumps, SV Series pumps are designed to operate fully or partially submerged. Avoid running the pump dry for extended periods of time. Refer to data sheet for minimum submersion depth for your particular model. Data sheets can be obtained by calling BJM Pumps, LLC at 860-399-5937. As a general rule, SV Series side discharge pumps can pump down to a level above the suction cover. Pumping lower than the cover will permit air to enter the pump and cavitate, lose prime or become air bound.



⚠ CAUTION

- Do not run the pump dry.
- Pump liquid should not exceed a maximum temperature of 104°F.
- Never place the pump on loose or soft ground. The pump may sink, preventing water from reaching the impeller. Place on a solid surface or suspend the pump with a lifting rope/chain. The SV Series pumps are provided with a suction strainer to prevent large solids from clogging the impeller. Any spherical solids which pass through the strainer should pass through the pump.
- For maximum pumping capacity, use the proper size non-collapsible hose or rigid piping. A check valve may be installed after the discharge to prevent back flow when the pump is shut off.

PUMP ROTATION

Two ways to check the correct pump rotation:

1. By looking at the impeller; the rotation of the impeller should be counter clockwise as shown in the picture below.

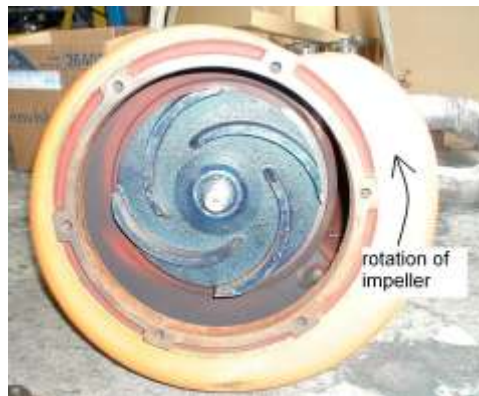

2. By looking from the top of the pump. Since the impeller cannot be seen, the best way to check the rotation is to check the kick back motion of the pump when the pump just starts. The kick back motion of the pump should be counter clockwise as shown in the picture below.



PUMP OPERATION

⚠ WARNING

This pump is designed to handle dirty water that contains some solids. It is not designed to pump volatile or flammable liquids. Do not attempt to pump any liquids which may damage the pump or endanger personnel as a result of pump failure.

⚠ DANGER

Do not operate this pump where explosive vapors or flammable material exist. Death or Serious injury will result.

TYPICAL MANUAL DEWATERING INSTALLATION

NOTE: Maximum recommended starts should not exceed 10 times per hour.

MANUAL OPERATION

All SV models are provided with a 33' (10 m) power cable. NEVER splice the power cable due to safety and warranty considerations. Always keep the plug end dry.

Note: 230V, single phase and 208V, 230V, 460V & 575V three phase units do not have a plug and have to be provided separately.

⚠ WARNING

Do not alter the length or repair any power cable with a splice. The pump motor and cable must be completely waterproof. Damage to the pump or personal injury may result from alterations.

For manual operation: 115 volt: plug the power cable into any 115 volt grounded receptacle. 208, 230, 460 & 575 volt: Attach the proper plug, connect directly to the power source or control box. Check the direction of the rotation. Tilt the pump and start it. It should twist in the opposite direction of the arrow (on pump). It is recommended that a Ground Fault Interrupter (GFI) type receptacle (or equivalent) be used.



⚠ WARNING

Single phase pumps always use a three-prong grounded receptacle. It is recommended that a Ground Fault Interrupter (GFI) type receptacle (or equivalent) be used.

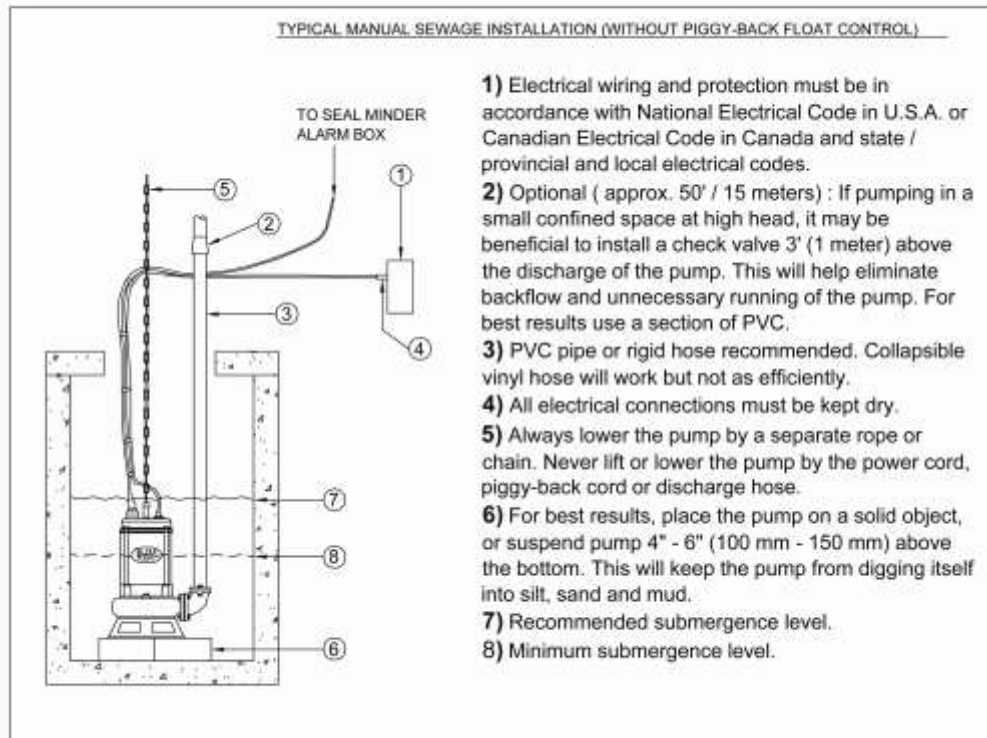

STOPPING

To stop the pump (manual and automatic mode), unplug it from the power source, turn off the breaker, or turn the power source off (generator).



Typical 3 phase manual control 1



TYPICAL AUTOMATIC DEWATERING INSTALLATION

NOTE: Maximum recommended starts should not exceed 10 times per hour.

AUTOMATIC OPERATION

Float switches (wired into the pump motor or piggy-back style) are available from the factory as an option.

Note: 208V, 230V, 460V & 575V pumps do not have a plug installed.

Three phase pumps need a separate control box with float(s) for automatic operation.

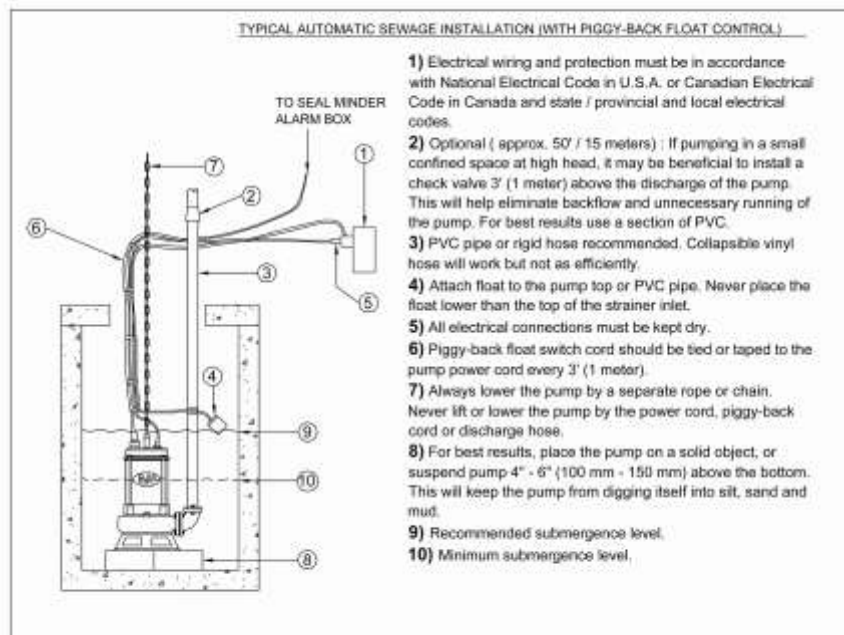

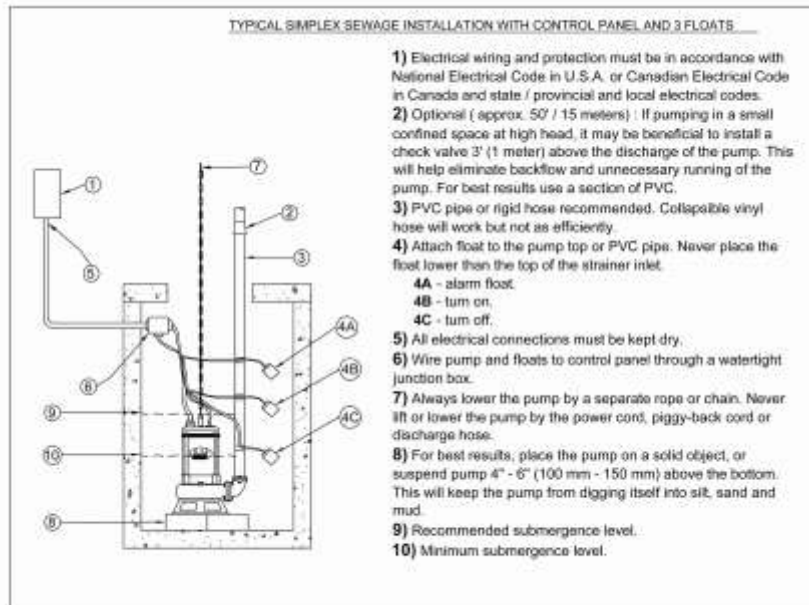

STOPPING

To stop the pump (manual and automatic mode), unplug it from the power source, turn off the breaker, or turn the power source off (generator).

INTENDED METHODS OF CONNECTION



Use with approved motor control that matches motor input in full load amperes. "UTILISER UN DÉMARREUR APPROUVÉ CONVIENT AU COURANT À PLEINE CHARGE DU MOTEUR."

BJM Pumps has been evaluated for use with water or water based solutions. Please contact the manufacturer for additional information.

SINGLE PHASE WIRING INSTRUCTIONS



FOR YOUR PROTECTION, ALWAYS DISCONNECT PUMP FROM ITS POWER SOURCE BEFORE HANDLING. Single phase pumps are supplied with a three prong grounded plug to help protect you against the possibility of electrical shock. **DO NOT UNDER ANY CIRCUMSTANCES REMOVE THE GROUND PIN.** The three prong plug **must** be inserted into a mating three prong grounded receptacle. **IF** the installation does not have such a receptacle it must be changed to the proper type, wired and grounded in accordance with the National Electrical Code and all applicable local codes and ordinances.



⚠ CAUTION “Risk of electrical shock” Do not remove power supply cable and strain relief or connect conduit directly to the pump.

⚠ WARNING Installation and checking of electrical circuits and hardware should be performed by a qualified licensed electrician.

THREE PHASE WIRING INSTRUCTIONS

⚠ WARNING FOR YOUR PROTECTION, ALWAYS DISCONNECT PUMP FROM ITS POWER SOURCE BEFORE HANDLING.

⚠ CAUTION “Risk of electrical shock” Do not remove power supply cable and strain relief or connect conduit directly to the pump.

⚠ WARNING Installation and checking of electrical circuits and hardware should be performed by a qualified licensed electrician.

To automatically operate a non-automatic three phase pump, a control panel is required. Follow the instructions provided with the panel to wire the system. For automatic three phase pumps see automatic three phase wiring diagram.

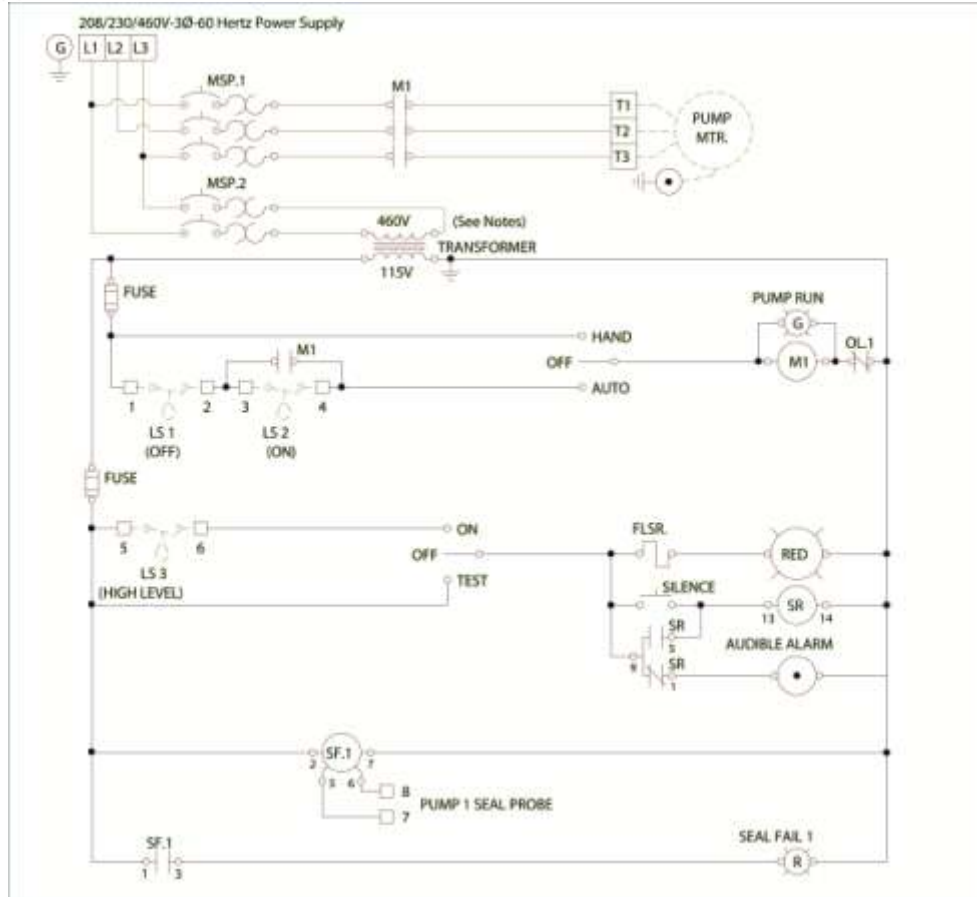

Typical 3 phase Auto Control 1

Before installing a pump, check the pump rotation to insure that wiring has been connected properly to power source, and that the green lead of power cable (See wiring diagram), is connected to a valid ground, momentarily energize the pump, observing the directions of kick back due to starting torque. Rotation is correct if kick back is in the opposite direction of rotation arrow on the pump casing. If rotation is not correct, switching of any two power leads other than ground will provide the proper rotation.

⚠ DANGER DO NOT PLACE HANDS IN PUMP SUCTION WHILE CHECKING MOTOR ROTATION. TO DO SO WILL CAUSE SEVERE PERSONAL INJURY.

BJM three phase pumps have integral motor overload protection. BJM recommends that all three phase pumps using a motor starting device also incorporate motor overload protection. Pumps **must** be installed in accordance with the National Electrical Code and all applicable local codes and ordinances. Pumps are not to be installed in locations classified as hazardous in accordance with National Electrical Code, ANSI/NFPA 70.

Connect pump to a junction box, outlet box, control box, enclosure with a wiring compartment that meets NEC and local codes. The provision for supply connection



shall reduce the risk of water entry during temporary, limited submersion and shall comply with the applicable requirements of the Standard for Enclosures for Electrical Equipment, UL 50, or the standard for Metallic Outlet Boxes, UL 514A, and the standard for Motor-Operated Water Pumps. UL 778.

TROUBLE SHOOTING



Disconnect the power source to the pump BEFORE attempting any type of trouble shooting, service or repair.

PUMP WILL NOT RUN

1. Check power supply (fuses, breaker). Reset power.
2. Blocked impeller. Remove strainer, check and clean.
3. Defective cable or incorrect wiring.
4. Strainer clogged. Check and clean as necessary.
5. Float switch tangled/obstructed. Clean and free float switch from obstruction.
6. Float switch defective. Replace float switch.
7. Pump overheated or temperature of liquid exceeds pump operating temperature.

Warning: Pump will restart automatically when motor over-heat protection switch cools.

PUMP RUNS BUT DOES NOT DELIVER RATED CAPACITY

1. Discharge line clogged, restricted or hose kinked. Check discharge hose/pipe.
2. Worn impeller and/or suction cover. Inspect and replace as necessary.
3. Pump overloaded due to liquid pumped being too thick.
4. Pumping air. Check liquid level and position of pump.
5. Excessive voltage drops due to long cables.
6. Three phase only; pump running backwards, check rotation.

SERVICING YOUR SUBMERSIBLE PUMP

Pump should be disconnected from the electric power supply before proceeding to do any service or maintenance.

To service or repair your pump, please contact your local BJM Pumps distributor. Service should only be performed by a qualified electrician.

MAINTAINING YOUR PUMP

- Pump should be disconnected from the electric power supply before proceeding to do any service or maintenance.



- Pump should be inspected at regular intervals.
- More frequent inspections are required if the pump is used in a harsh environment.
- Preventative maintenance should be performed to reduce the chance of premature failure.
- Worn impellers and lip seals should be replaced.
- Cut or cracked power cables must be replaced. **(Never operate a pump with a cut, cracked or damaged power cable.)**
- Seal oil should be checked once per year.
- Maintenance should always be done when taking a pump out of service before storage.
 - 1) Clean pump of dirt and other build up.
 - 2) Check condition of oil around the shaft seals.
 - 3) Check hydraulic parts: check for wear.
 - 4) Inspect power cable. Make sure that it is free of nicks or cuts.

CHANGING SEAL OIL

Changing the seal oil in the SV series pumps is very easy.

- 1) Make sure that the pump cable is disconnected from the power source.
- 2) Lay the pump down on its side.
- 3) Remove the screws that hold the bottom plate in place.
- 4) Remove bottom plate.
- 5) Remove screws holding the suction cover.
- 6) Remove the suction cover.
- 7) Remove the impeller.
- 8) Remove the inspection screw for the oil chamber (pos#50-08). Pour out a small sample of the oil. If it is milky white, or contains water, then the oil and possible, the mechanical seal, should be changed. If an oil change is needed:
- 9) Remove the screws that hold the oil chamber cover in place & remove the oil.
- 10) Replace the mechanical seal if necessary.
- 11) Replace the oil.
- 12) Reassemble the pump.

EXPLODED VIEW OF SV400

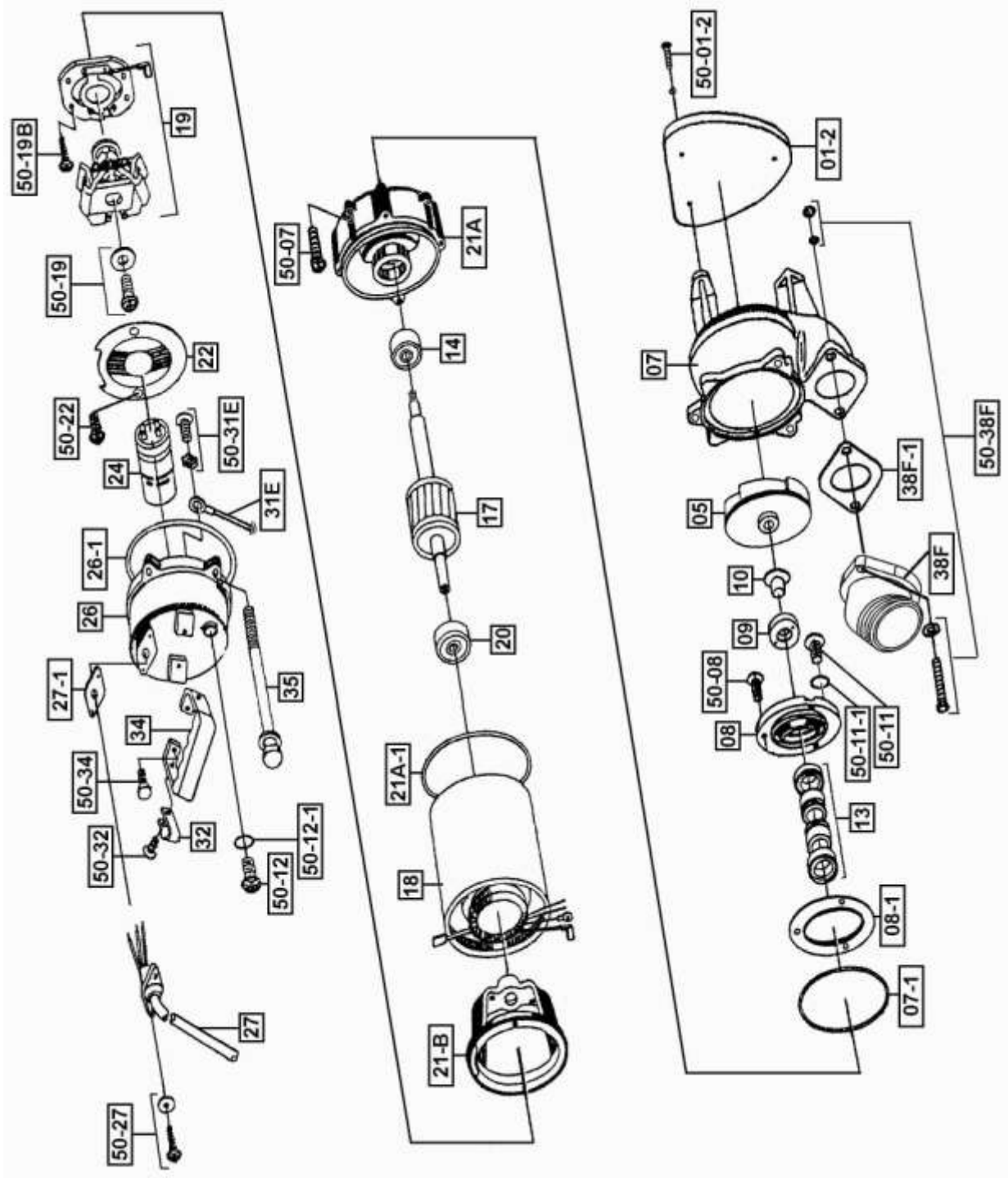

EXPLODED VIEW OF SV750

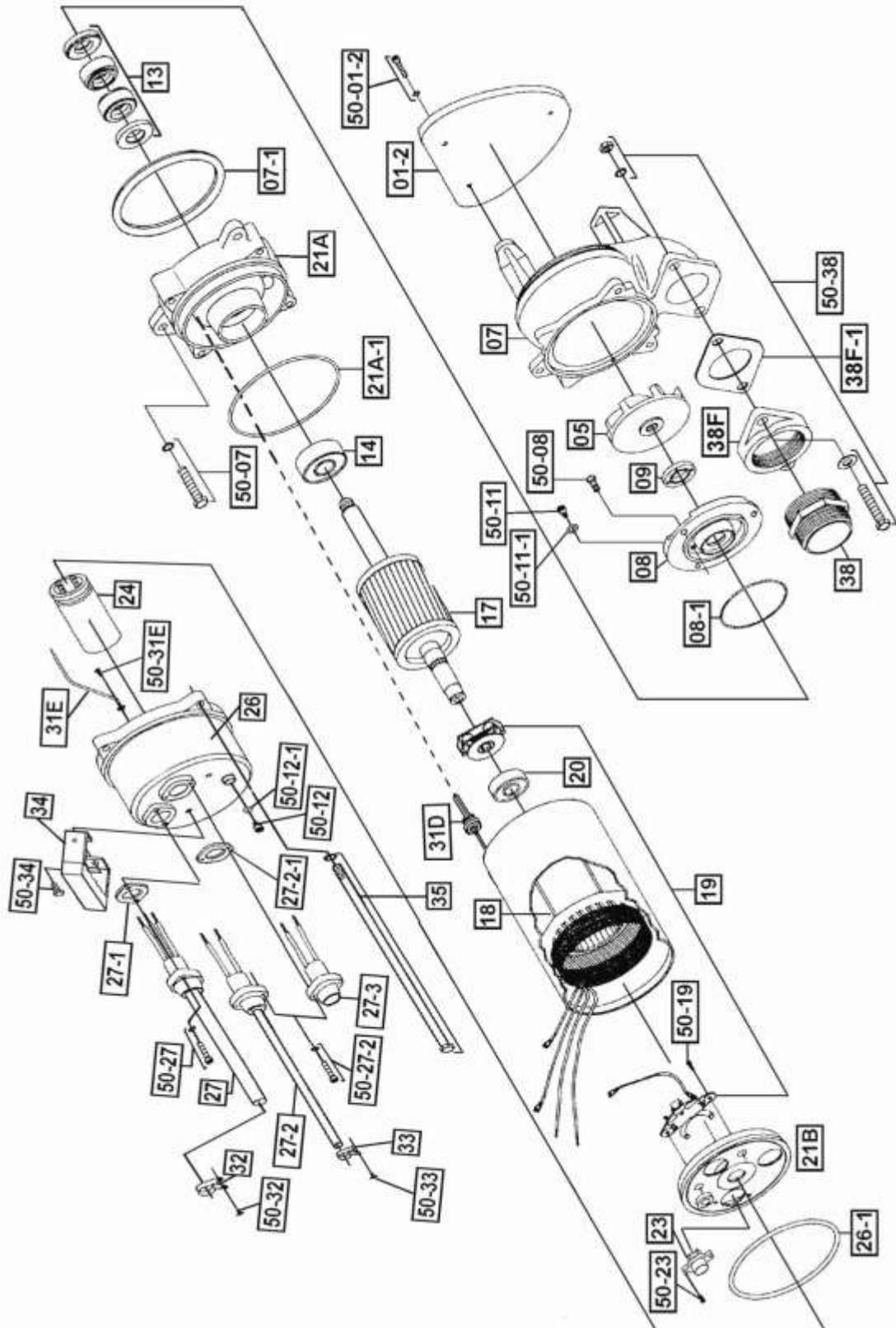

EXPLODED VIEW OF SV750C

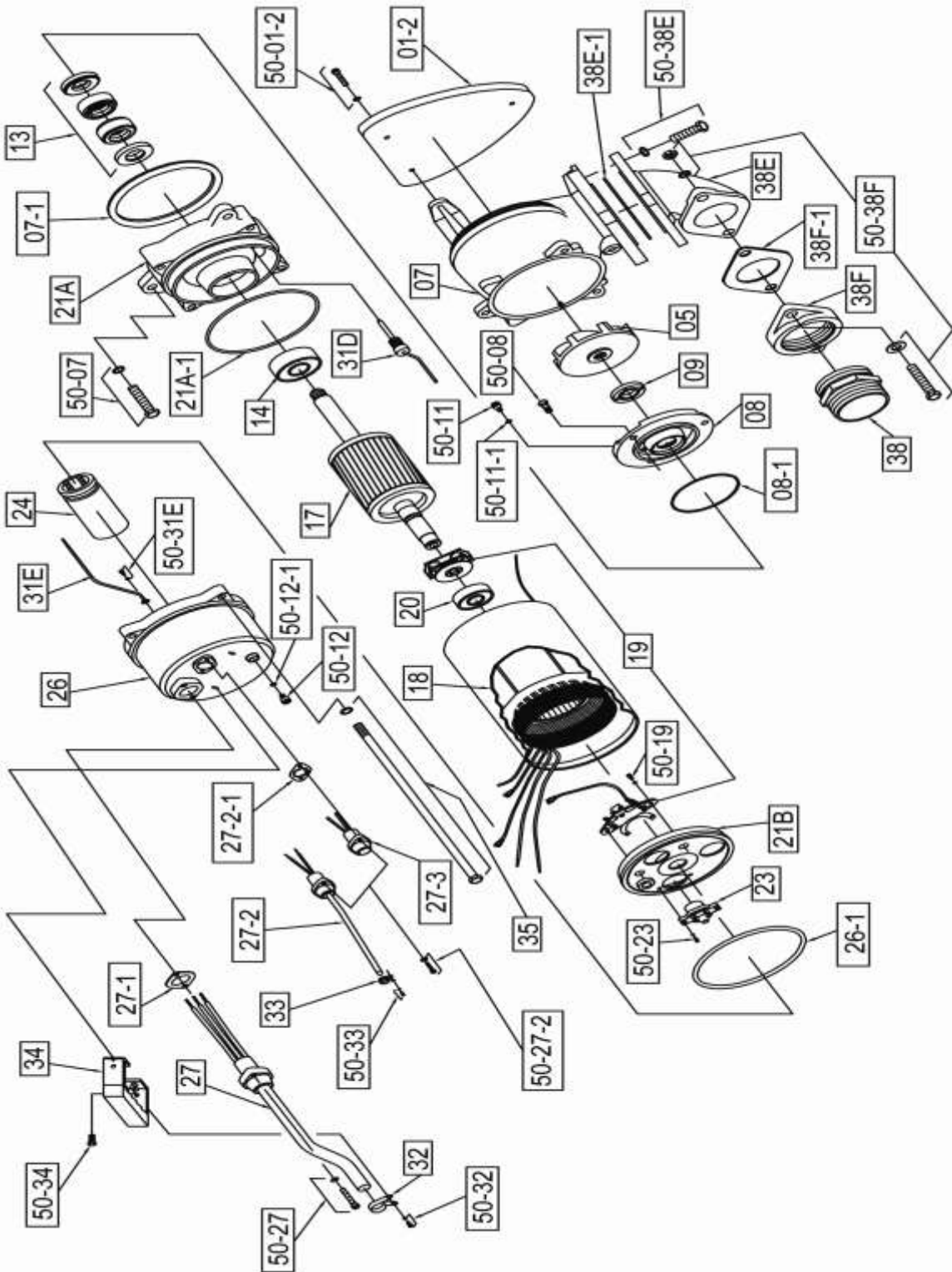

EXPLODED VIEW OF SV1500

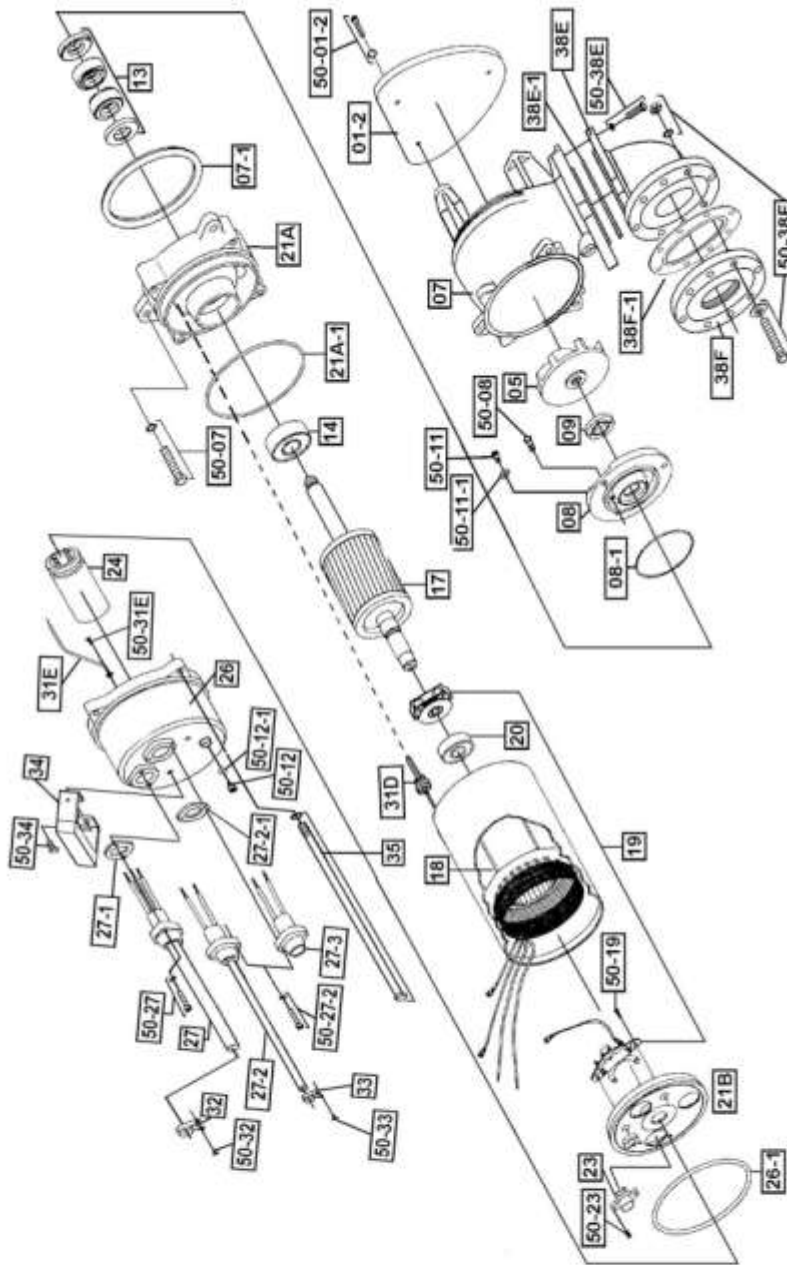

NOTE: Seal Minder (Pos#27-2,33,50-33) is an optional component. SV Series pumps come with Seal Minder cap only (Pos#27-3)



EXPLODED VIEW OF SV08

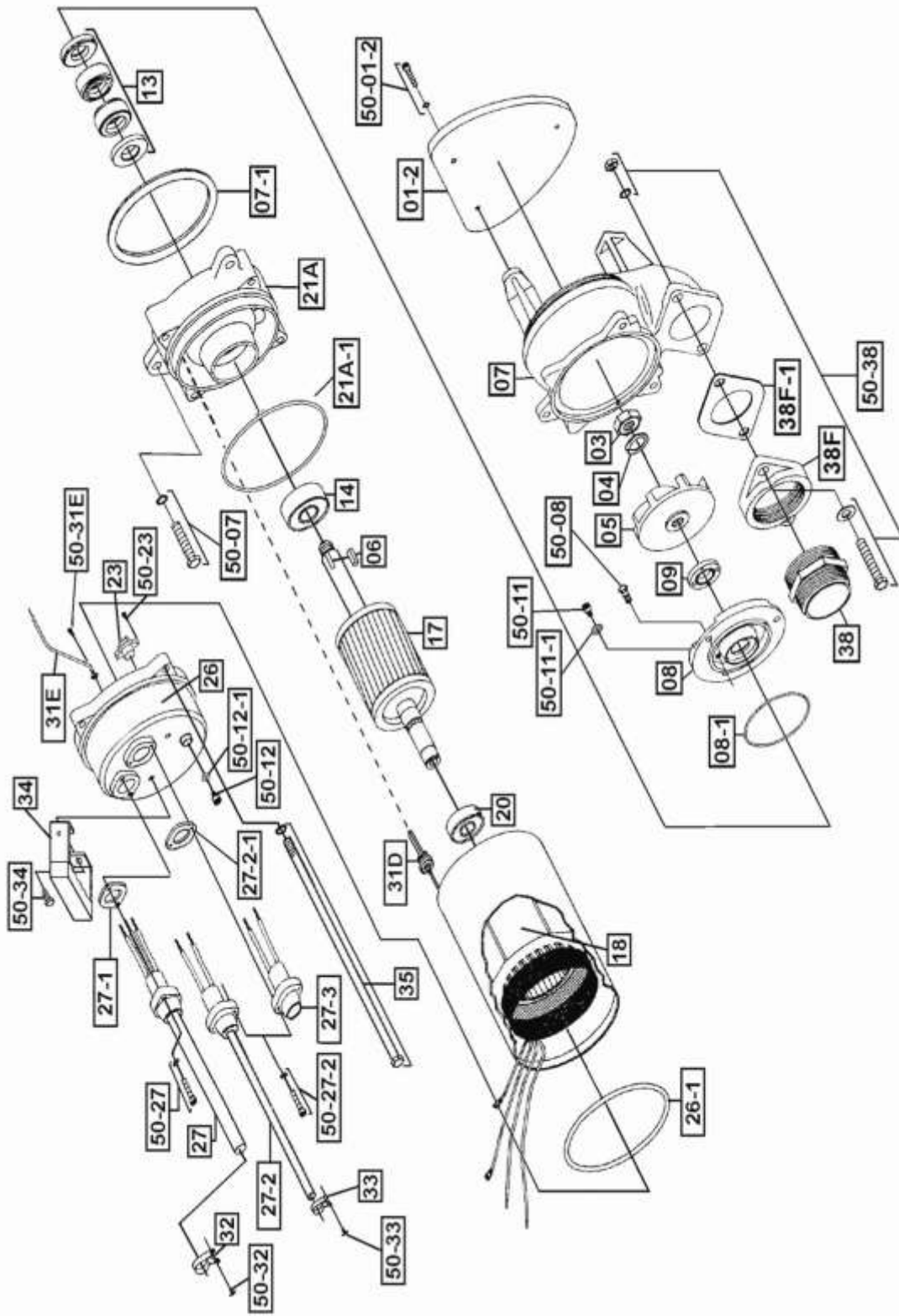



EXPLODED VIEW OF SV08C

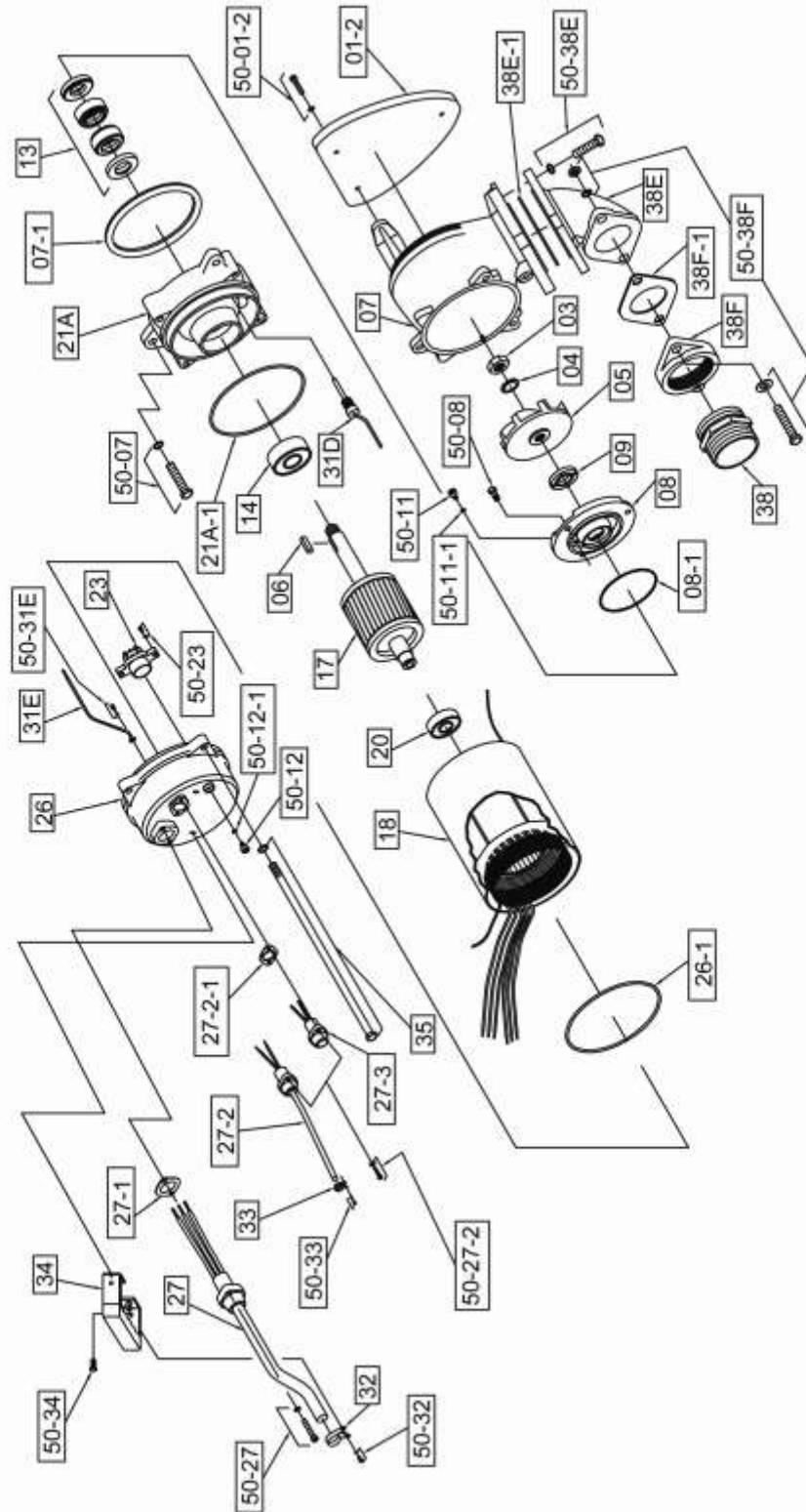



EXPLODED VIEW OF SV15

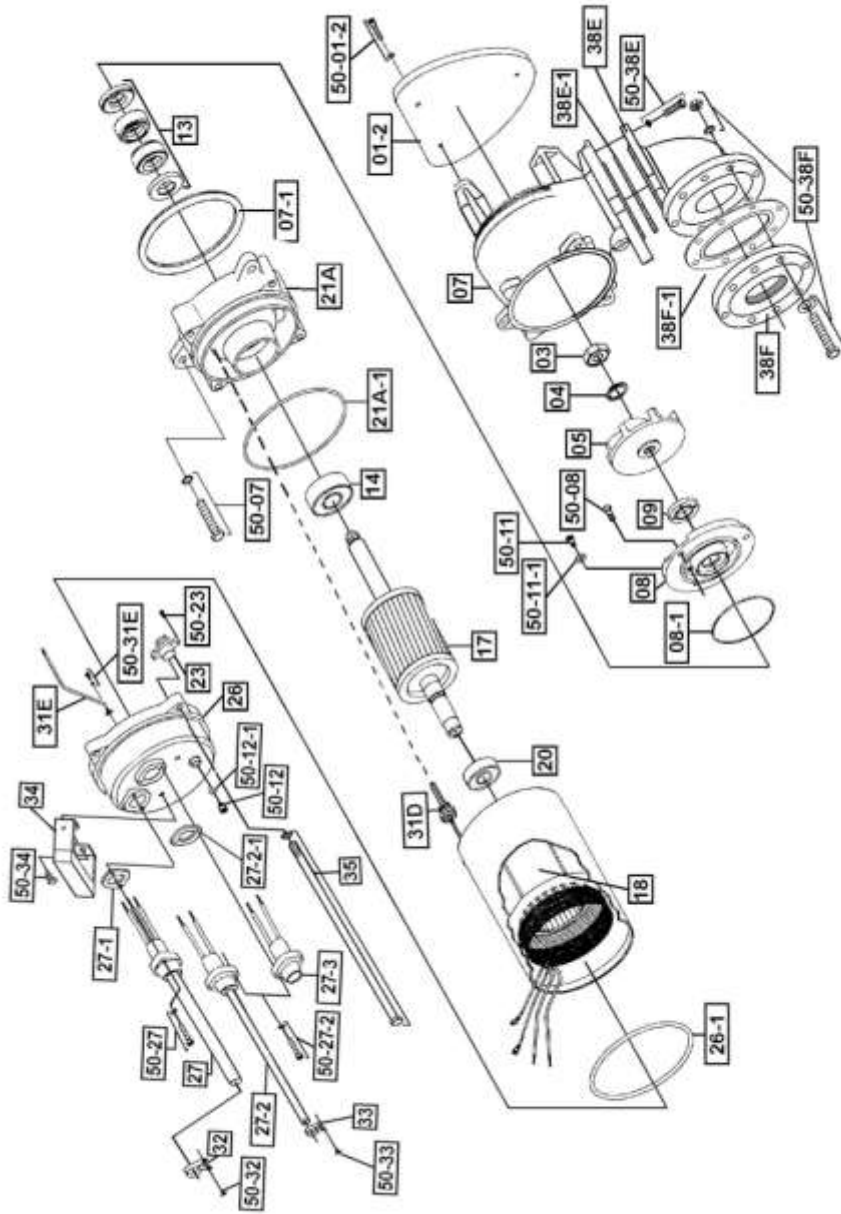

11-7-13



EXPLODED VIEW OF SV22, SV37

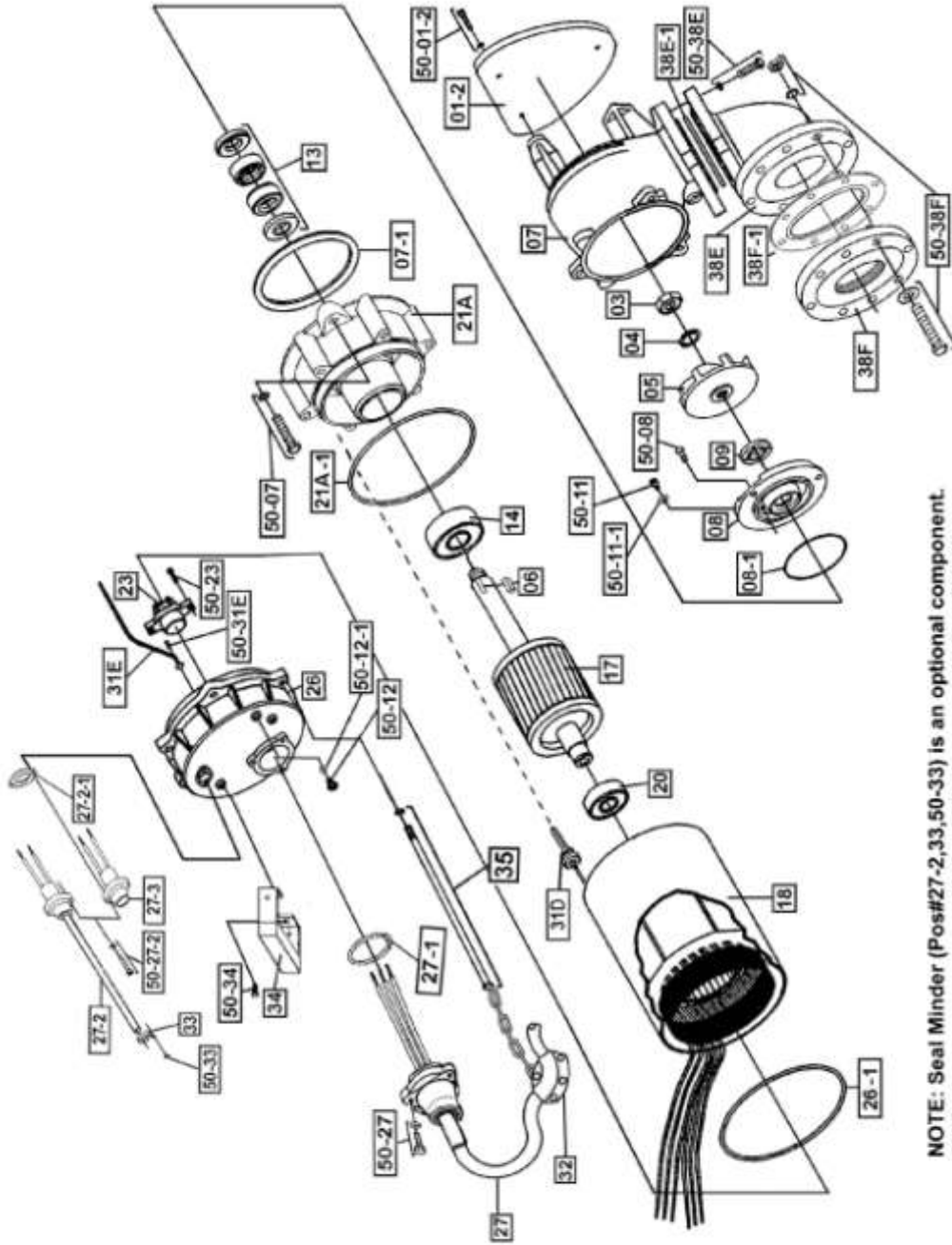

CAT ID# XVIEW SV22- SV37

NOTE: Seal Minder (Pos#27-2,33,50-33) is an optional component.
SV Series pumps come with Seal Minder cap only (Pos#27-3)

11-7-13



EXPLODED VIEW OF SV55, SV75

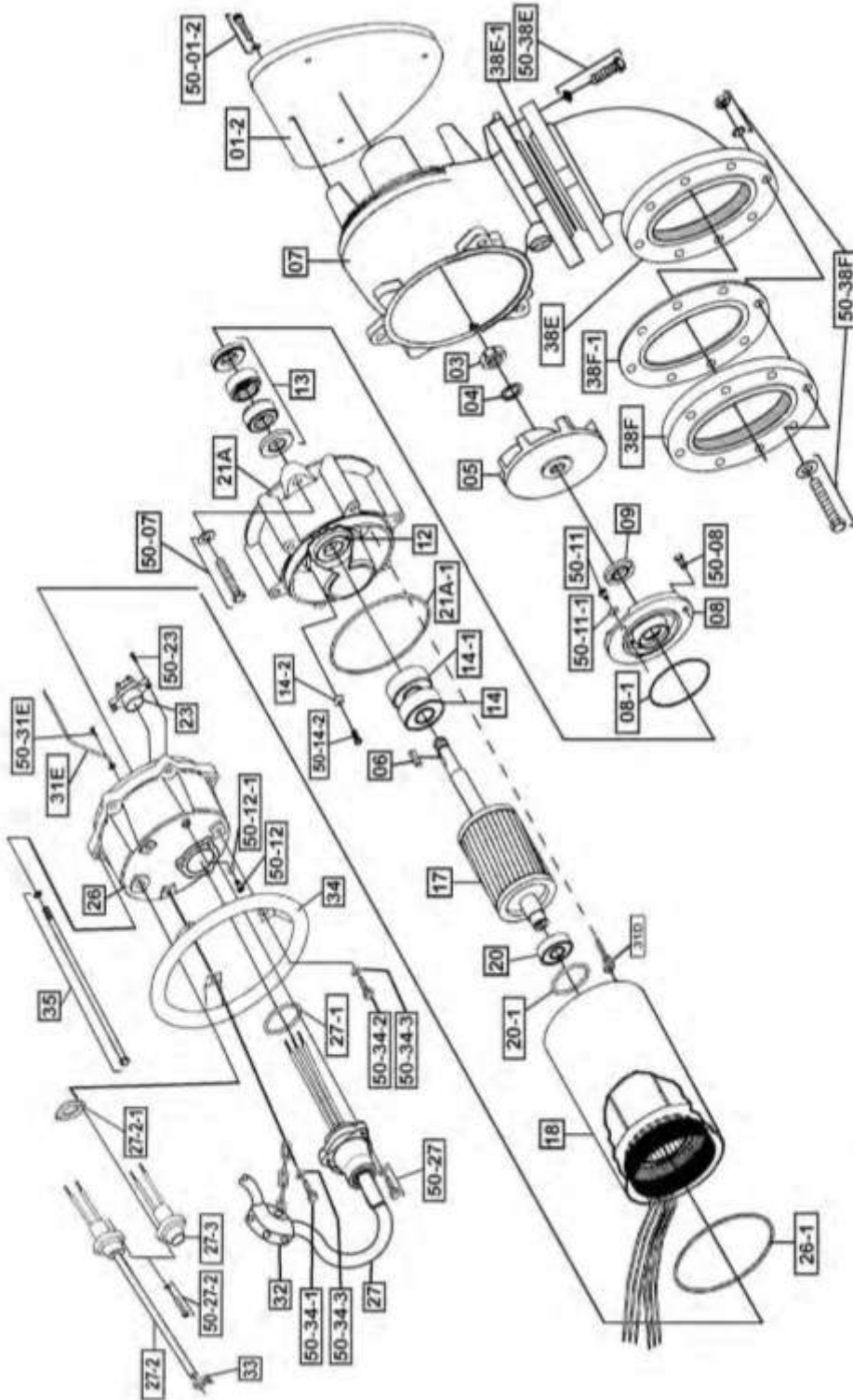

NOTE: Seal Minder (Pos#27-2,33,50-33) is an optional component.
SV Series pumps come with Seal Minder cap only (Pos#27-3)

SV SERIES PARTS LIST

	Pump Model	SV250	SV400	SV750	SV750C	SV1500	SV08	SV08C	SV15	SV22	SV37	SV55	SV75
Pos. No.	Part Description	Item #	Item #	Item #	Item #	Item #	Item #	Item #	Item #	Item #	Item #	Item #	Item #
01-2	Bottom Plate	202868	202868	202037	202037	202035	202037	202037	202035	201018	201018	202036	202036
03	Impeller Nut	202890	-	-	-	-	202894	202894	202894	202894	202894	202895	202895
04	Washer	-	-	-	-	-	202907	202907	202907	202907	202907	202904	202904
05	Impeller Vortex	202923	202114	202115	202115	202116	202118	202118	202119	202120	202121	202129	202130
06	Impeller Key	-	-	-	-	-	202140	202140	202140	202140	202140	202141	202141
07	Pump Housing w/ Bottom Plate	202185	202185	202186	203016	202187	202186	203016	202187	202188	202188	203023	203023
07-1	O-Ring (Kit Only)	Kit	Kit	Kit	Kit	Kit	Kit	Kit	Kit	Kit	Kit	-	-
08	Oil Chamber Cover	202207	202207	202211	203045	202211	202211	203045	202211	203046	203046	203048	203048
08-1	O-Ring (Kit Only)	Kit	Kit	Kit	Kit	Kit	Kit	Kit	Kit	Kit	Kit	Kit	Kit
09	Lip Seal Buna-N	202229	202229	202231	202231	202231	202231	202231	202231	202247	202247	202239	202239
10	Shaft Sleeve	202258	202258	-	-	-	-	-	-	-	-	-	-
12	Lip Seal Buna-N	-	-	-	-	-	-	-	-	-	-	202236	202236
13	Mechanical Seal Buna-N	202259	202259	200501	200501	200501	200501	200501	200501	200302	200302	200305	200305
13	Mechanical Seal FKM**	202260	202260	200500	200500	200500	200500	200500	200500	200301	200301	200304	200304
14	Lower Ball Bearing	200493	200493	200958	200958	200958	200958	200958	200958	200959	200959	200961	200961
14-1	Lower Ball Bearing	-	-	-	-	-	-	-	-	-	-	200961	200961
14-2	Lower Bearing Retainer	-	-	-	-	-	-	-	-	-	-	202279	202279
17	Rotor w/ Shaft 115/ 230V, 1 PH	202305	202302	203086	203086	-	-	-	-	-	-	-	-
17	Rotor w/ Shaft 230V, 1 PH	-	-	-	-	203091	-	-	-	-	-	-	-
17	Rotor w/ Shaft, 3PH	-	-	-	-	-	202306	202306	202310	202322	202323	202347	202348
18	Stator Coil w/ Casing 115V, 1PH	1810	200509	200511	200511	-	-	-	-	-	-	-	-
18	Stator Coil w/ Casing 230V, 1PH	200646	200521	200570	200570	200514	-	-	-	-	-	-	-
18	Stator w/ Casing 208V, 3PH	-	-	-	-	-	200524	200524	200528	200540	200542	200544	-
18	Stator w/ Casing 230/460V, 3PH	-	-	-	-	-	200546	200546	200550	200614	200620	200651	200653
18	Stator w/ Casing 575V, 3PH	-	-	-	-	-	200588	200588	200592	200647	200649	200655	200657
19	Governor Switch w/ Switch Plate	-	202359	202360	202360	202360	-	-	-	-	-	-	-
20	Upper Ball Bearing	200957	200957	200967	200967	200967	200967	200967	200967	200958	200958	200959	200959
20-1	O-Ring (Kit Only)	-	-	-	-	-	-	-	-	-	-	Kit	Kit
21A	Oil Chamber Housing	200498	200498	203017	203018	203019	203017	203018	203019	203020	203020	203021	203021
21A-1	O-Ring (Kit Only)	Kit	Kit	Kit	Kit	Kit	Kit	Kit	Kit	Kit	Kit	Kit	Kit
21B	Motor Cover Upper	204154	202365	202368	202368	202368	-	-	-	-	-	-	-
22	Motor Cover Plate	-	202380	-	-	-	-	-	-	-	-	-	-
23	Overload Protector 115V, 1PH	-	-	202383	202383	-	-	-	-	-	-	-	-
23	Overload Protector 230V, 1PH	-	-	202395	202395	202383	-	-	-	-	-	-	-
23	Overload Protector 208V, 3PH	-	-	-	-	-	202385	202385	202388	202390	202392	202394	-
23	Overload Protector 230V, 3PH	-	-	-	-	-	202385	202385	202388	202390	202392	202394	202396
23	Overload Protector 460V, 3PH	-	-	-	-	-	202387	202387	202386	202389	202391	202393	202394
23	Overload Protector 575V, 3PH	-	-	-	-	-	202399	202399	202387	202386	202389	202391	202393
24	Capacitor 115V	202412	202415	202417	202417	-	-	-	-	-	-	-	-
24	Capacitor 230V	202413	202416	202418	202418	202420	-	-	-	-	-	-	-
26	Pump Top Cover	203120	203120	202433	202433	202433	202435	202435	202435	202445	202445	202439	202439
26-1	O-Ring (Kit Only)	Kit	Kit	Kit	Kit	Kit	Kit	Kit	Kit	Kit	Kit	Kit	Kit
27	Power Cable w/ Gland-115V, 1PH	201682	204257	204258	204258	-	-	-	-	-	-	-	-

27	Power Cable w/ Gland-230V, 1PH, No Plug	201684	201684	201694	201694	201694	-	-	-	-	-	-	-
27	Power Cable w/ Gland- 3PH	-	-	-	-	-	201701	201701	201701	203442	203444	203446	203446
27-1	O-Ring (Kit Only)	Kit	Kit	Kit	Kit	Kit	Kit	Kit	Kit	Kit	Kit	Kit	Kit
27-2	Seal Minder Cable	-	-	202763	202763	202763	202763	202763	202763	202763	202763	202763	202763
27-2-1	O-Ring (Kit Only)	-	-	Kit	Kit	Kit	Kit	Kit	Kit	Kit	Kit	Kit	Kit
27-3	Oil Sensor Cap	-	-	203139	203139	203139	203139	203139	203139	203139	203139	203139	203139
31D	Seal Minder Probe	-	-	202409	202409	202409	202409	202409	202409	203998	203998	204000	204000
31E	Ground Wire w/ Ring Term.	203145	203145	203145	203145	203145	203145	203145	203145	203145	203145	203145	203145
32	Power Cord Line Clip	203161	203161	203161	203161	203161	203161	203161	203161	204161	204161	204161	204161
33	Seal Minder Cable Line Clip	-	-	203163	203163	203163	203163	203163	203163	203163	203163	203163	203163
34	Handle	202517	202517	202517	202517	202517	202517	202517	202517	202517	202517	203171	203171
35	Rods Bolts	202675	202665	202666	202666	202668	202669	202669	202670	202671	202672	202673	202674
38	Discharge Nipple 2"	-	202531	202531	202531	-	202531	202531	-	-	-	-	-
38	Discharge Nipple 3"	-	-	202534	202534	202534	202534	202534	202534	202534	202534	-	-
38E	Discharge Elbow	-	-	-	202558	202557	-	202558	202557	202557	202557	202572	202572
38E-1	Gasket, Disch. Elbow, Buna-N	-	-	-	203208	203208	-	203208	203208	203208	203208	203210	203210
38F	Discharge Flange 2", 45°	202569	202569	-	-	-	-	-	-	-	-	-	-
38F	Discharge Flange 2"	-	202562	202543	202543	-	202543	202543	-	-	-	-	-
38F	Discharge Flange 3"	-	-	202545	202545	203188	202545	202545	203188	203188	203188	-	-
38F	Discharge Flange 4"	-	-	-	-	202606	-	-	202606	202606	202606	202575	202575
38F	Discharge Connection, 4" FNPT	-	-	202552	202552	-	202552	202552	-	-	-	-	-
38F-1	Gasket, Disch. Flange, Buna-N	203206	203206	202659	202659	201564	202659	202659	201564	201564	201564	202661	202661
50-01-2	Screw for Bottom Plate	203216	203216	203216	203216	203216	203216	203216	203216	203220	203220	203220	203220
50-07	Screw for Pump Housing	203238	203238	203283	203283	203283	203283	203283	203283	203229	203229	203229	203229
50-08	Screw for Oil Chamber Cover	203215	203215	203219	203219	203219	203219	203219	203219	203219	203219	203220	203220
50-11	Screw for Oil Fill	203218	203218	203218	203218	203218	203218	203218	203218	203218	203218	203218	203218
50-11-1	O-Ring (Kit Only)	Kit	Kit	Kit	Kit	Kit	Kit	Kit	Kit	Kit	Kit	Kit	Kit
50-12	Screw for Pressure Check	203218	203218	203218	203218	203218	203218	203218	203218	203218	203218	203218	203218
50-12-1	O-Ring (Kit Only)	Kit	Kit	Kit	Kit	Kit	Kit	Kit	Kit	Kit	Kit	Kit	Kit
50-14-2	Screw Bearing Retainer	-	-	-	-	-	-	-	-	-	-	203219	203219
50-19	Screw for Gov. Switch	-	202693	202693	202693	202693	-	-	-	-	-	-	-
50-19B	Screw for Gov. Switch Plate	-	203215	-	-	-	-	-	-	-	-	-	-
50-22	Screw for Cover Plate	-	203214	-	-	-	-	-	-	-	-	-	-
50-23	Screw for Overload	-	-	202700	202700	202700	202700	202700	202700	202700	202700	202700	202700
50-27	Screw for Power Cord	203295	203295	203216	203216	203216	203216	203216	203216	203220	203220	203220	203220
50-27-2	Screw for Seal Minder Cable	-	-	203216	203216	203216	203216	203216	203216	203216	203216	203216	203216
50-31E	Screw for Ground Wire	202692	202692	202692	202692	202692	202692	202692	202692	202692	202692	202692	202692
50-32	Screw for Line Clip	203214	203214	203214	203214	203214	203214	203214	203214	203214	-	-	-
50-33	Screw for Line Clip	-	-	203214	203214	203214	203214	203214	203214	203214	203214	-	-
50-34	Bolt for Handle	203219	203219	203219	203219	203219	203219	203219	203219	203219	203219	-	-
50-34-1	Bolt for Handle w/ Cable Chain	-	-	-	-	-	-	-	-	-	-	203228	203228
50-34-2	Bolt for Handle	-	-	-	-	-	-	-	-	-	-	-	203288
50-34-3	Lock Washer	-	-	-	-	-	-	-	-	-	-	202902	202902
50-38E	Bolt for Discharge Elbow	-	-	-	203267	203267	-	203267	203267	203267	203267	203286	203286
50-38F	Bolt for Discharge Flange	203230	203230	203253	203253	203277	203253	203253	203277	203277	203277	203277	203277
O-Ring Kit - Buna N		203191	203191	202634	202634	202634	203192	203192	203192	203193	203193	202650	202650



SINGLE PHASE WIRING DIAGRAM 115V & 230V W/GOVERNOR SWITCH

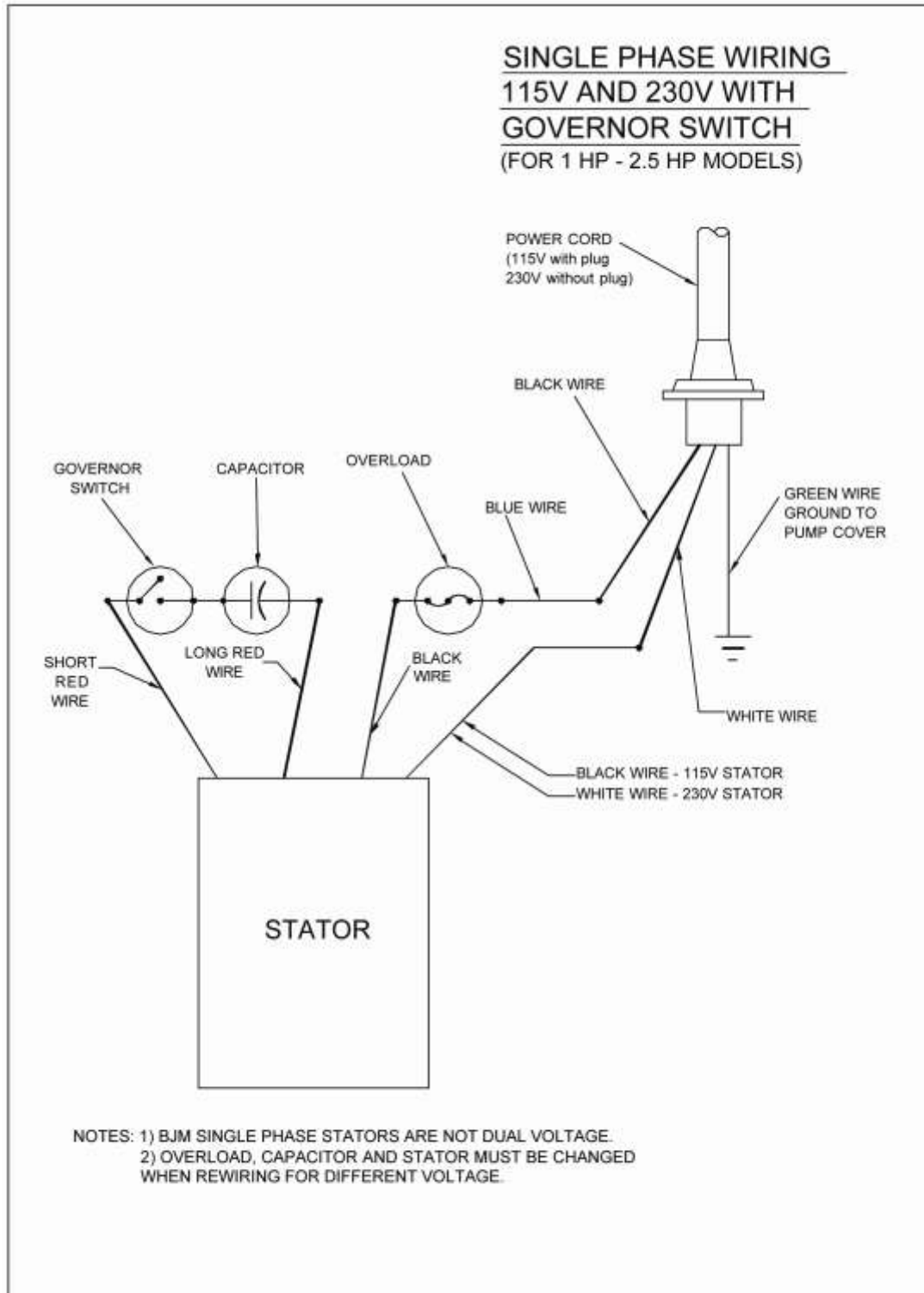

MODELS SV400, SV750, SV750C, SV1500



THREE PHASE WIRING DIAGRAMS

208V

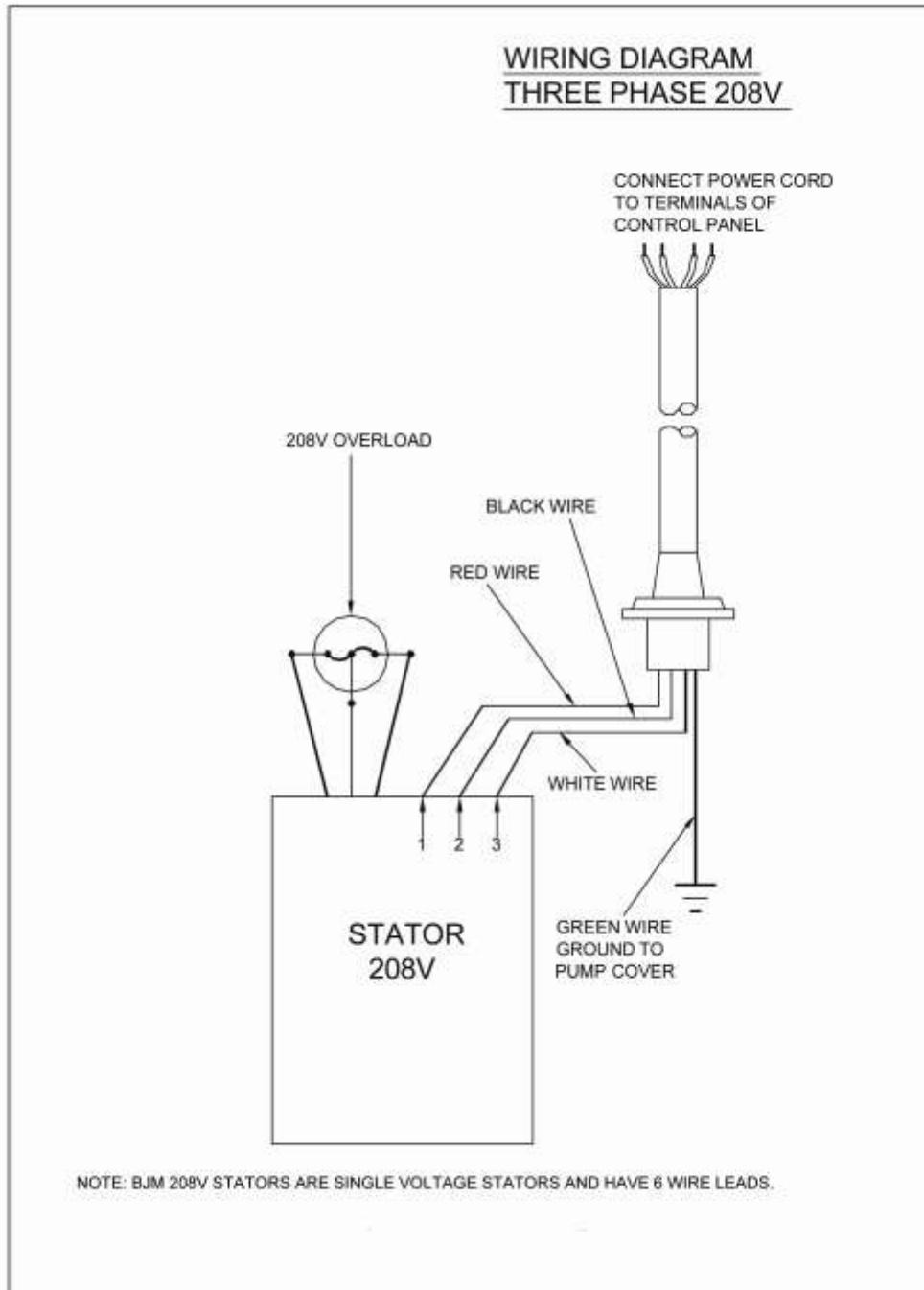

MODELS SV08, SV08C, SV15, SV22, SV37, SV55



230V

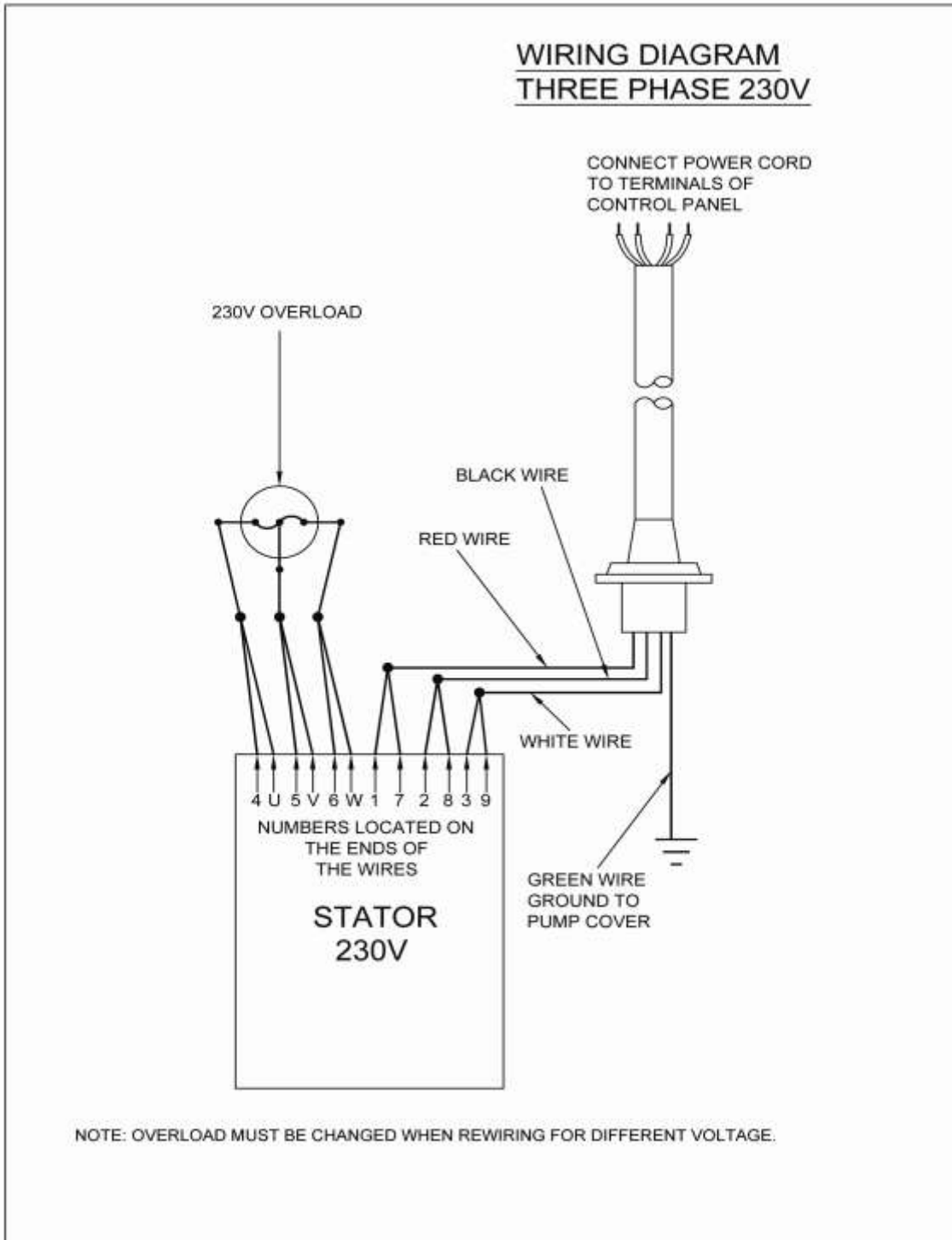

MODELS SV08, SV08C, SV15, SV22, SV37, SV55, SV75



460V

WIRING DIAGRAM THREE PHASE 460V

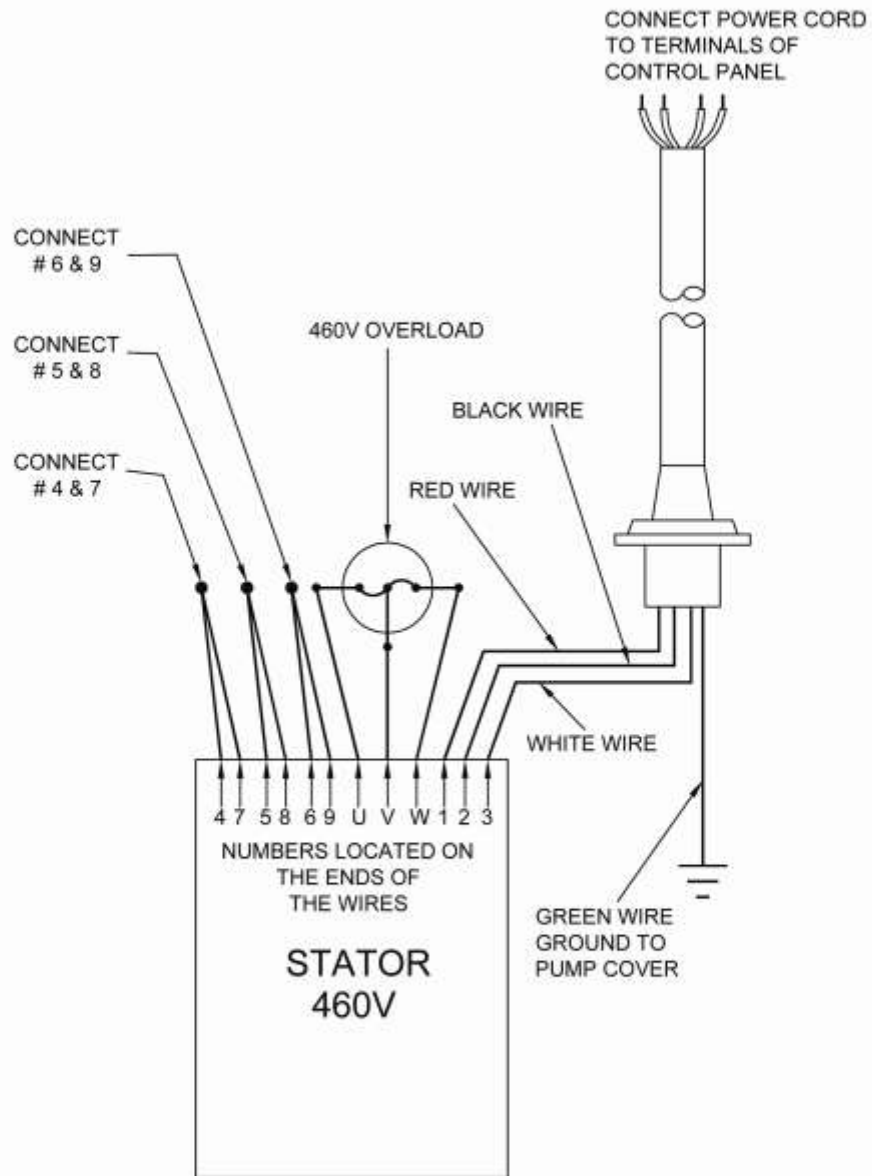

NOTE: OVERLOAD MUST BE CHANGED WHEN REWIRING FOR DIFFERENT VOLTAGE.

MODELS SV08, SV08C, SV15, SV22, SV37, SV55, SV75



575V

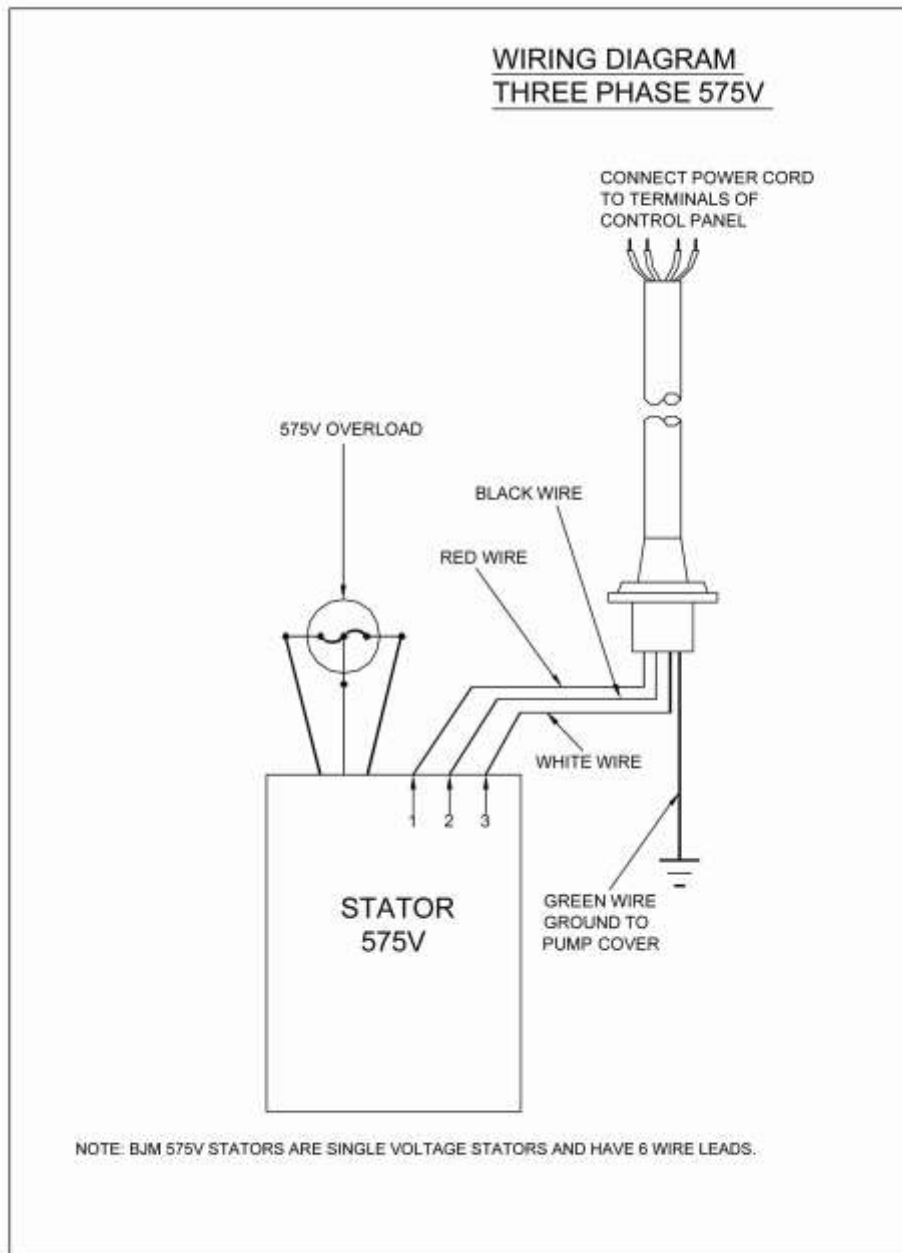

MODELS SV08, SV08C, SV15, SV22, SV37, SV55, SV75

SEAL MINDER



Seal Minder™ INFORMATION

Seal Minder™ :

Also known as a seal failure circuit (or moisture detection circuit) is designed to inform the pump operator that there is moisture within the oil chamber. This early warning can allow the operator to schedule repair & inspection on the pump. The Seal Minder™ is a sensor probe inside the oil chamber. (The oil chamber houses the mechanical seals that are cooled & lubricated by oil). The Seal Minder™, when properly connected to a control panel, can help indicate seal failure. The Seal Minder™ requires a seal fail circuit in control panel for warning signal.

The open end of the Seal Minder™ circuit cord should be connected to a control panel with an optional seal fail relay or a stand alone seal fail panel. Please contact BJM for more information on Seal Minder™ alarm boxes & control panels, or visit www.bjmpumps.com.

The Seal Minder™ cord only has 2 leads (1=black, 1=white). The power cord is much larger in diameter & has 3, 4, or 5 leads depending on model pump, voltage & phase.

The black lead on the Seal Minder™ cord should be connected to the panel "terminal" going to the relay ground. (NOTE: Do not connect the black wire to the panel ground screw). The white lead on the Seal Minder™ cord should be connected to the panel "terminal" going to the probe. For proper wiring, please see detailed panel information.

Panel manufacturers can incorporate Seal Minder™ option. BJM has a stand alone, Seal Minder™ panel for both simplex(P/N MSP8350A) and duplex(P/N MSP8350B) systems. For more information contact BJM Pumps, LLC or visit us online at www.bjmpumps.com.

Although recommended, the pump does not need a control box with seal fail relay or stand alone seal panel to operate.

If the operator does not use the Seal Minder™:

1) The recommended procedure is to take the Seal Minder™ cord off the pump and seal with a BJM Seal Minder™ cap (part# M02738) & gasket (part# M05121 for Buna, part# M05121V for Viton). This should be done by an authorized BJM service center or distributor as not to void warranty. Detailed instruction sheet available for this procedure.

2) Alternate method of securing Seal Minder™ cable if not being used: Tape the Seal Minder™ cord to the power cord. Make sure that the cords are taped together in an even run, at about 2' to 3' apart. Use electrical tape to tape off the end of the Seal Minder™ cable (Do not connect to power source). The taped leads should be kept dry & out of the liquid.(See next page for detailed drawing)

SPECIFICATIONS SUBJECT TO CHANGE WITHOUT NOTICE.

BJM Pumps, LLC - 123 SPENCER PLAIN ROAD, OLD SAYBROOK, CT 06475 - PHONE: 860-399-5937 - FAX: 860-399-7784

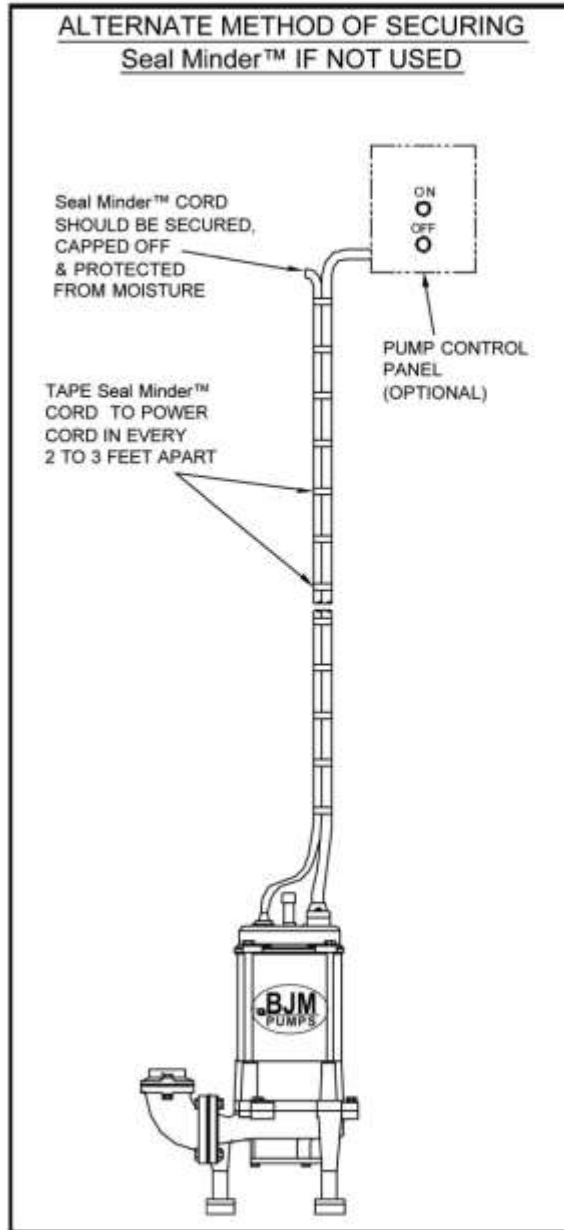
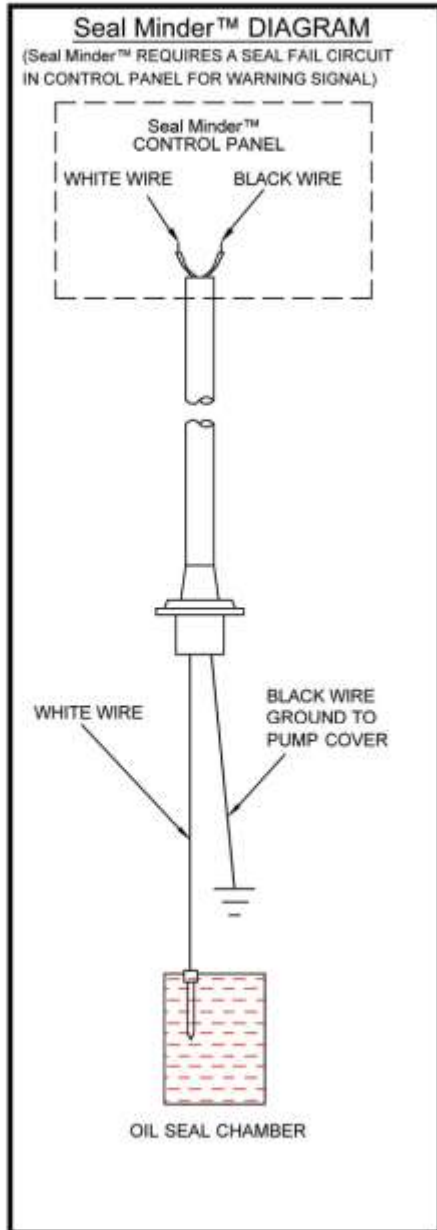

SPECIFICATIONS SUBJECT TO CHANGE WITHOUT NOTICE.

BJM Pumps, LLC - 123 SPENCER PLAIN ROAD, OLD SAYBROOK, CT 06475 - PHONE: 860-399-5937 - FAX: 860-399-7784

BJM PUMPS, LLC
123 Spencer Plain Road
Old Saybrook, CT 06475, U.S.A.

WARRANTY AND LIMITATION OF LIABILITY

Unless otherwise expressly authorized in writing, specifying a longer or shorter period, BJM Pumps, LLC warrants for a period of eighteen (18) months from the date of shipment from the Point of Shipment, or one (1) year from the date of installation, whichever occurs first, that all products or parts thereof furnished by BJM Pumps, LLC under the brand name BJM Pumps, hereinafter referred to as the "Product" are free from defects in materials and workmanship and conform to the applicable specification.

BJM Pumps, LLC's liability for any breach of this warranty shall be limited solely to replacement or repair, at the sole option of BJM Pumps, LLC, of any part or parts of the Product found to be defective during the warranty period, provided the Product is properly installed and is being used as originally intended. Any breach of this warranty must be reported to BJM Pumps, LLC or BJM Pumps, LLC's authorized service representative within the aforementioned warranty period, and defective Product or parts thereof must be shipped to BJM Pumps, LLC or BJM Pumps, LLC's authorized representative, transportation charges prepaid. Any cost associated with removal or installation of a defective Product or part is excluded.

IT IS EXPRESSLY AGREED THAT THIS SHALL BE THE SOLE AND EXCLUSIVE REMEDY OF BJM PUMPS, LLC'S DISTRIBUTORS AND CUSTOMERS. UNDER NO CIRCUMSTANCES SHALL BJM PUMPS, LLC BE LIABLE FOR ANY COSTS, LOSS, EXPENSE, DAMAGES, SPECIAL DAMAGES, INCIDENTAL DAMAGES OR CONSEQUENTIAL DAMAGES ARISING DIRECTLY OR INDIRECTLY FROM THE DESIGN, MANUFACTURE, SALE, USE OR REPAIR OF THE PRODUCT, WHETHER BASED ON WARRANTY, CONTRACT, NEGLIGENCE, OR STRICT LIABILITY. IN NO EVENT WILL LIABILITY EXCEED THE PURCHASE PRICE OF THE PRODUCT.

THE WARRANTY AND LIMITS OF LIABILITY CONTAINED HEREIN ARE IN LIEU OF ALL OTHER WARRANTIES AND LIABILITIES, EXPRESSED OR IMPLIED. ALL IMPLIED WARRANTIES OF MERCHANTABILITY AND FITNESS FOR A PARTICULAR PURPOSE ARE HEREBY DISCLAIMED BY BJM PUMPS, LLC AND EXCLUDED FROM THIS WARRANTY.

BJM Pumps, LLC neither assumes, nor authorizes any person to assume for it, any other warranty obligation in connection with the sale of the Product. This warranty shall not apply to any Product or parts of Product which have (a) been repaired or altered outside of BJM Pumps, LLC's facilities unless such repair was authorized in advance by BJM Pumps, LLC or by its authorized representative; or (b) have been subject to misuse, negligence or accident; or (c) have been used in a manner contrary to BJM Pumps, LLC's instruction.

In any case of products not manufactured and sold under the BJM Pumps, LLC brand name, there is no warranty from BJM Pumps, LLC; however BJM Pumps, LLC will extend any warranty received from BJM Pumps, LLC's supplier of such products.

START-UP REPORT FORM

START-UP REPORT FORM

This form is designed to record the initial installation, and to serve as a guide for troubleshooting at a later date (if needed).

BJM Pumps, LLC
 123 Spencer Plain Road
 Old Saybrook, CT. 06475

Pump Owner's Name			
Location of Installation		Date of Installation:	
Dealer		Dealer Phone ()	
Date of Purchase			
Model		Serial No	
Voltage	Phase	Hertz	HP
Does impeller turn freely by hand?		<input type="checkbox"/> Yes	<input type="checkbox"/> No
Condition of Equipment		<input type="checkbox"/> New	<input type="checkbox"/> Good <input type="checkbox"/> Fair <input type="checkbox"/> Poor
Condition of Cable Jacket		<input type="checkbox"/> New	<input type="checkbox"/> Good <input type="checkbox"/> Fair <input type="checkbox"/> Poor
Rotation: Direction of Impeller Rotation (viewed from bottom) (Use C/W for clockwise, CC/W for counterclockwise): _____			
Resistance of cable and Pump Motor (measured at pump control)			
Red-Black_____ohms		Red-White_____ohms	
		White-Black_____ohms	
Resistance of ground circuit between control panel and outside of pumps _____ Ohms			
MEG OHM CHECK OF INSULATION			
Red to ground_____ White to ground_____ Black to ground_____			
Condition of location at start-up		<input type="checkbox"/> Dry	<input type="checkbox"/> Wet <input type="checkbox"/> Muddy
Was equipment stored		<input type="checkbox"/> Yes	<input type="checkbox"/> No.
If YES, length of storage:			
Liquid being pump			
Debris in bottom of station?		<input type="checkbox"/> Yes	<input type="checkbox"/> No

START-UP REPORT FORM

Are guide rails vertical?	<input type="checkbox"/> Yes	<input type="checkbox"/> No
Is base elbow installed level?	<input type="checkbox"/> Yes	<input type="checkbox"/> No
Liquid level controls: Model _____		
Is control installed away from turbulence?	<input type="checkbox"/> Yes	<input type="checkbox"/> No
Float Operation Check		
Tip lowest float (stop float), all pumps should remain off. Tip second float (and stop float), one pump comes on. Tip third float (and stop float), both pumps on (alarm on simplex). Tip fourth float (and stop float), high level alarm on (omit on simplex).		
<input type="checkbox"/> Check here if using manual on/off only.		
Does liquid level ever drop below volute top?	<input type="checkbox"/> Yes	<input type="checkbox"/> No
Control Panel MFG & model no.		
Number of pumps operated by control panel		
NOTE: At no time should hole be made in top of control panel, unless proper sealing devices are utilized.		
Short Circuit protection:	Type:	
Number and size of short circuit device(s)	Amp rating:	
Overload type:	Size:	Amp rating:
Do protective devices comply with pump motor amp rating?	<input type="checkbox"/> Yes	<input type="checkbox"/> No
Are all pump connections tight?	<input type="checkbox"/> Yes	<input type="checkbox"/> No
Is the interior of the panel dry?	<input type="checkbox"/> Yes	<input type="checkbox"/> No If No, correct moisture problem.
Electrical readings		
SINGLE PHASE		
Voltage supply at panel line connection, pump off	L1	L2
Voltage supply at panel line connection, pump on	L1	L2
Amperage load connection, pump on	L1	L2
THREE PHASE		
Voltage supply at panel line connection, pump off		
L1-L2	L2-L3	L3-L1
Voltage supply at panel line connection, pump on		

START-UP REPORT FORM

L1-L2	L2-L3	L3-L1
Amperage load connection, pump on		
L1	L2	L3
FINAL CHECK		
Is pump secured properly?	<input type="checkbox"/> Yes	<input type="checkbox"/> No
Was pump checked for leaks?	<input type="checkbox"/> Yes	<input type="checkbox"/> No
Do check valves operate properly?	<input type="checkbox"/> Yes	<input type="checkbox"/> No
Flow: Do pumps appear to operate at proper rate?	<input type="checkbox"/> Yes	<input type="checkbox"/> No
Noise level:	Acceptable <input type="checkbox"/>	Unacceptable <input type="checkbox"/>
Comments:		
Installed by:		
Company:		
Person:		
Date:		



4/23/2010
0814
Supersedes
0813



TECHNICAL DATA
MODEL SV1500
BJM SUBMERSIBLE PUMP - CAST IRON
GENERAL DATA

MAX. FLOW: GPM (L/min)	171 GPM (647 L/min)
MAX. HEAD: ft (m)	29' (8.8 m)
MAX. SUBMERSION DEPTH: ft (m)	65' (20m) or limited to length of power cord, Consult factory for deeper depths
PUMP TYPE	NON CLOG VORTEX
MINIMUM SUBMERSION DEPTH: in(mm)	14.5" (368 mm)
SOLID SIZE: in (mm)	2.5" (64 mm)
IMPELLER DIAMETER: in (mm)	3.74" (95 mm)
DISCHARGE SIZE	3" NPT-FEMALE
SLIDE RAIL SYSTEM	3"
PUMP WEIGHT, without cable: lbs (kg)	92 lbs (41.8 kg)
SHIPPING WEIGHT: lbs (kg)	104 lbs. (47.3 kg)

CONSTRUCTION / MATERIAL DATA

MECHANICAL SEAL - UPPER	CARBON/CERAMIC
MECHANICAL SEAL - LOWER	SILICON CARBIDE/SILICON CARBIDE
MOTOR HOUSING	304 SS
PUMP VOLUTE	CAST IRON
IMPELLER	VORTEX, CAST IRON
LIP SEALS & O-RINGS	BUNA-N
ROTOR SHAFT	304 SS
EXTERNAL HARDWARE	304 SS
QTY. OIL IN SEAL CHAMBER	9.3 U.S. FL. OZ. (275 C.C.)
QTY. OIL IN MOTOR STATOR	No oil in motor stator (After ser# 43644). 13.5 U.S. FL. OZ. (400 C.C.) (Before ser# 43644).
BALL BEARING: PERM. LUBE. UPPER	6203
BALL BEARING: PERM. LUBE. LOWER	6304

ELECTRICAL / MOTOR DATA

MOTOR: TYPE, RATING HP	SUBMERSIBLE, 2 (CONTINUOUS DUTY ³)
MOTOR RPM	3450
MOTOR INSULATION CLASS	F
MOTOR SERVICE FACTOR	1.1
VOLTAGE ¹	230, 1 PH, 60 Hz
CURRENT F.L.A.	14
LOCKED ROTOR CURRENT (LRA)	65
MOTOR PROTECTION	THERMAL & AMP. OVERLOAD
POWER CORD: GAGE; LENGTH	A.W.G. 14/3; 33' (10m), STOW
MAXIMUM LIQUID TEMPERATURE	104°F (40°C)
SEAL LEAK DETECTOR ² (OPTIONAL)	Seal Minder®; MOISTURE SENSING PROBE

1- Available in other voltages (and in 50 Hz).

2- Requires a seal fail circuit in control panel for warning signal.

3 - Continuous duty motor – see minimum submersion depth at General Data table above.

©2004 - 2010 BJM Pumps, LLC. All rights reserved.

123 Spencer Plain Road

Old Saybrook, CT. 06475, USA

(860)399-5937 - (877) BJM-PUMP - Fax: (860)399-7784

REFER TO REVERSE SIDE FOR PUMP PERFORMANCE CURVES

SPECIFICATIONS SUBJECT TO CHANGE WITHOUT NOTICE

Seal Minder is a registered trademark of BJM Pumps, LLC. All rights reserved.



MODEL: SV1500

