



BN Products - USA, LLC

Products for the Construction Industry

3450 Sabin Brown Road • Wickenburg, AZ 85390
(800) 992-3833 • mail@bnproducts.com

Operating Instructions

BNT-40X • BNT-25X • BNT-58X
Automatic Rebar Tying Machines

These tools have
Passed ISO9001 International
Quality System Certification
The charger has passed ETL Certification



BNT-25X



BNT-40X



BNT-58X



Please read this manual carefully before using this machine to make sure you are familiar with all safety and warning instructions.



Please read this manual carefully before using this machine to make sure you are familiar with all safety and warning instructions.

Machine Call-Outs

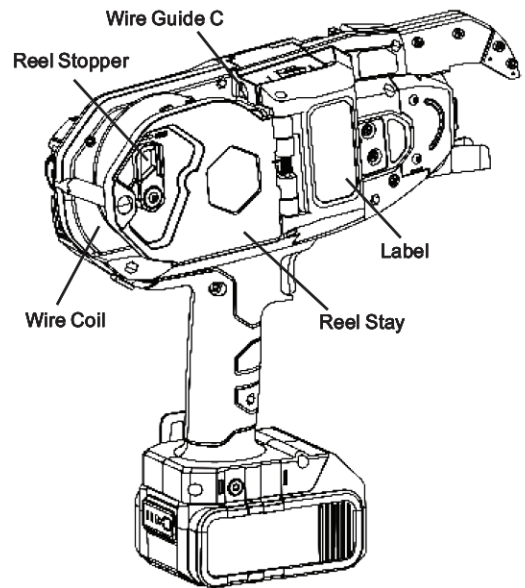
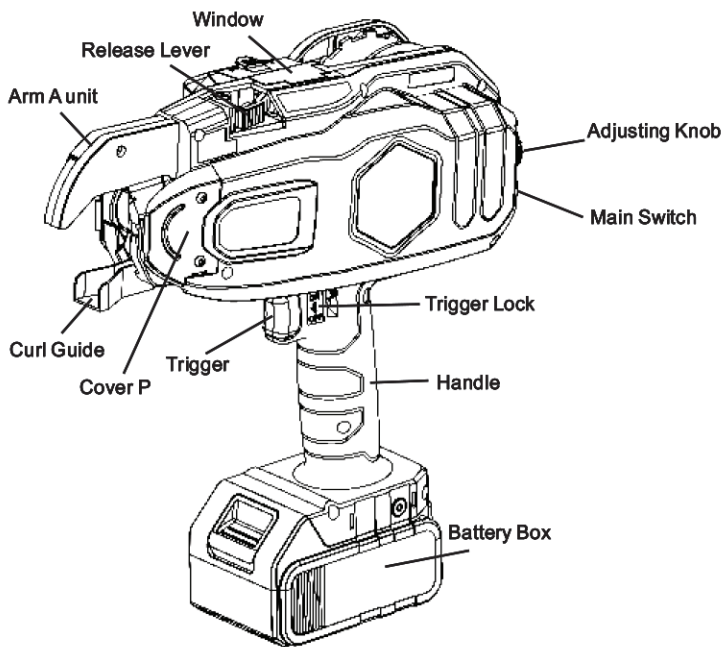

Battery

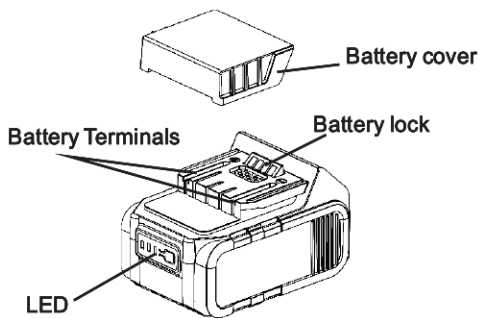

Charger

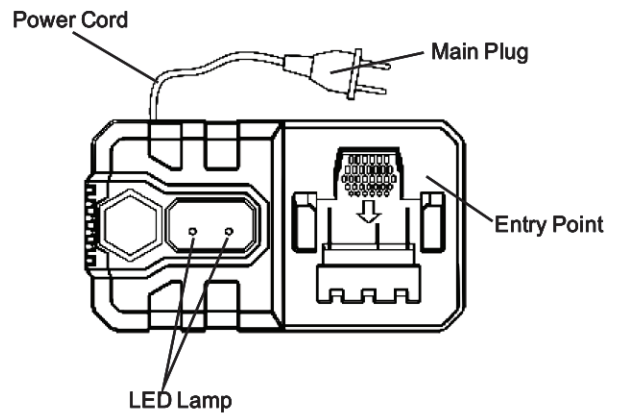

Safety

This machine is a high-performance battery operated tool. Failure to follow the warnings and instructions may result in an electric shock, fire or serious injuries.

- Always operate the tool with personal protection equipment (including eye protection, etc.). Using the appropriate safety equipment at all times will avoid body injury.
- Keep children and bystanders away while operating this tool. Distractions may cause serious accidents.
- Do not aim the tool at those standing around your work area. Serious accidents can happen if you mishandle this tool.
- Do not place your hand or position the machine near your body. This could cause serious injury.
- Do not attempt to dismantle, modify or perform any major maintenance on this tool. Modifications may result in a deterioration of the tool's performance and may cause serious injury and void the warranty.
- Make sure that the main switch is in the off position when the tool is not being used or when abnormalities occur. When changing or adjusting the wire coil, or when changing the battery pack, make sure to turn off the main power switch and lock the trigger.
- Do not place fingers or hands in the wire coil area. This may result in distortion of the coil and may cause injury to you.
- Do not operate this tool in the rain or areas where moisture is present. This may result in electrical shock or accident.
- Stay particularly alert while working in a high area. Do not operate any power tool under the influence of drugs, alcohol, or medication. A moment of inattention may result in serious injury to you or someone near you.
- Do not operate this tool in a hazardous area containing flammable liquid, gas or powders which may ignite and cause a fire.
- The charger has been designed to use standard AC power (100-240V ~ 50-60Hz). Do not recharge the battery using a generator power supply as this will cause the charger to malfunction.
- Our batteries charge best when the ambient temperature is between 32°F and 113°F. Super-cooling or over-heating environments are not suitable for charging.
- Continuous use of the charger is not advised as this will shorten the life span of the battery and the performance of the charger itself. When not in the charging mode the power supply must be turned off.
- Please do not carry the charger by the cord. Do not pull out the power cord from the wall socket with the cord, this will damage the cord and break the wires or

cause a short circuit. A damaged cord must be repaired or replaced immediately.

- Use only the specified charger that came with your machine. Using an unauthorized charger may result in damage to the battery components and possible explosion.
- Avoid battery terminal contact with other metal objects. Trying to recharge the battery with an external wire could result in a short circuit of the battery.
- Do not throw away the protective battery cap. Use it to cover the terminal when not in use.

Safety Locks

Make sure that all safety features are operational before using any power tool.

DO NOT OPERATE THE TOOL IF THE SAFETY LOCKS ARE NOT FUNCTIONAL.

This tool is equipped with the following safety devices:

The Main Switch: Please turn the main switch off when not in operation.

The Trigger Lock: Always turn the trigger lock to the off position when not in use or when changing the wire spool.

Technical Data			
Tool Specs			
Product No.	BNT-25x	BNT-40x	BNT-58x
Weight Information			
Tool Only	4.15 lbs. (1.9 kg)	4.45 lbs. (2.02 kg)	4.85 lbs. (2.2 kg)
Tool + Battery	5.5 lbs. (2.5 kg)	5.8 lbs. (2.63 kg)	6.2 lbs. (2.8 kg)
Tool+Battery +Spool	6.4 lbs. (2.91 kg)	6.7 lbs. (3.04 kg)	7.1 lbs. (3.22 kg)
Height	11.81 in. (300mm)	11.81 in. (300mm)	12.2 in. (310mm)
Width	4.29 in. (109mm)	4.29 in. (109mm)	4.29 in. (109mm)
Length	11.06 in. (281mm)	11.69 in. (297mm)	12.28 in. (312mm)
Ties per coil	160 - 220	120 - 160	90 - 120
Wraps per Tie	3 Wraps/tie		
Time per Tie	0.6 - 0.8 sec per tie		
Max Tying Diameter	1" (25mm)	1.575" (40mm)	2.283" (58mm)
	#3 x #4 bar	#6 x #6 bar	#8 x #8 bar
Battery	Li-Ion 18V, 4.0Ah, 72Wh (BNTLI-18)		

Ties Per Charge	4000-5000 ties per charge
Additional Charger (BNTLI-18C)	
Holster (BNH-40)	
Extension Arm (BNEX-40)	
Electronic Extension Arm ()	
Humidity	80% RH or less

Wire Technical Parameters

Part No. BNT-40-Wire	
Diameter (in.)	ø 0.03 (21 Gauge)
Material	Q195 Galvanized
Length (in.)	3937 (approx)
Part No. BNT-40-Wire-USA	
Diameter (in.)	ø 0.03 (21 Gauge)
Material	Q195 Galvanized
Length (in.)	3937 (approx)
Part No. BNT-40-Wire-P	
Diameter (in.)	ø 0.03 (21 Gauge)
Material	Q195 Polycoated
Length (in.)	3937 (approx)

Battery and Charger Usage

Before inserting or removing the battery from this tool, please set the main switch to the off position.

- To avoid a short circuit to the battery, always use the battery terminal cover when it is not in use with the tool.
- When placing the battery into the tool, press the battery lock before placing it into the battery holder. When removing the battery, press the battery lock button before pulling it out of the battery holder.
- Use 100-240V ~ 50-69Hz AC power supply for the charger. Fully insert the battery into the charger slot and it will begin to charge automatically as indicated by the charging light. It will take approximately 74 minutes to fully complete the battery charge.
- It is recommended to charge the battery between 32°F and 113°F. Do not charge in extreme cold or hot environments.

Machine Operation and Methods

Before inserting and removing the wire spool turn the main power switch to the off position, lock the trigger switch and remove the battery.

**When installing the wire coil spool.
only use recommended wire
without rust in this tool.**

Only use recommended wire spools. Using non-standard wire or spool could cause the tool to malfunction.

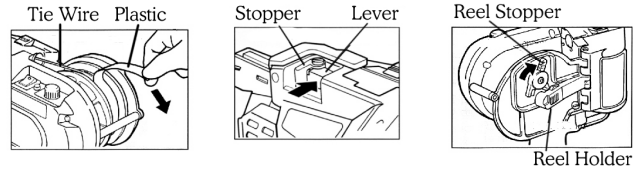

- Cut about 2 inches of wire from the coil.
- Push the reel stopper to release the reel stay and open the gate at the same time.
- Install the wire pool with the left side facing the tool. Lock the opening by closing the reel holder door.

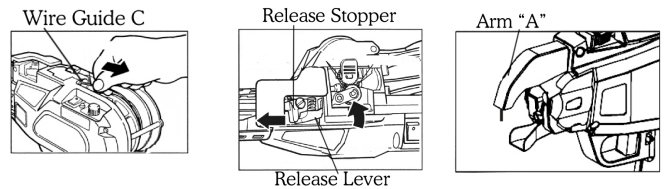

- Insert the wire into the wire guide "C" (Note: the wire must not be bent or curved).
- The wire must pass through the wire guide "C" in between the two feeding gears until it reaches the flared tub. Then push the wire an additional 1/2" into the flared tub.
- Keep pushing the wire until it reaches the arm "A" unit.
- Release the release stopper and confirm the release lever has returned to its original position. (Note: the wire must be clamped by the feeding gears).
- Remove the rest of the remaining adhesive tape from the wire spool if any.
- Install the battery into the machine, when you hear a locking sound the battery has been installed correctly. (Note: make sure that the main power switch is in the off position and that the trigger is locked before installing the battery).
- Turn on the main power switch. The machine is now ready for use.

How to remove the wire coil spool

- Turn off the main power switch, lock the trigger and remove the battery.
- Press the release lever and confirm that it is caught in the open position.
- Remove the plastic wire spool.

The Tying Procedure

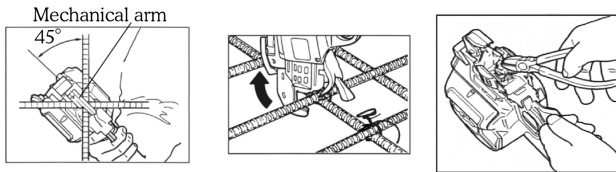

Unlock the trigger lock. Keep the mechanical arm on the rebars to be tied with a 45° angle at a vertical position to the rebars.

Press the trigger and the tool will tie automatically.

Remove the tool when the tying is complete.

Do not press the trigger when the mechanical arm is not on the rebar surface. (Note: if this should happen turn off the machine, position the trigger lock to the “off” position and remove the trapped wire with a pair of pliers inside the machine mouth).

Adjust the tie tightness. There are 5 tightness levels that can be adjusted with the “adjusting dial”.

Replacement of Gears

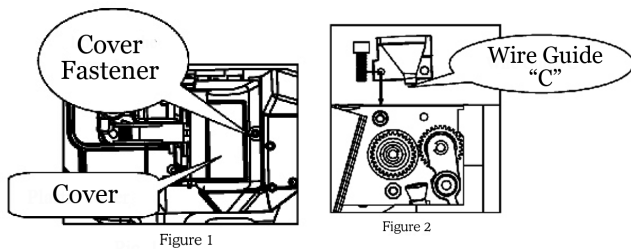

- Remove the screw that fastens the plastic housing over the motor as show above.
- Remove the wire guide “C” which is fastened on the plate as shown on previous page.

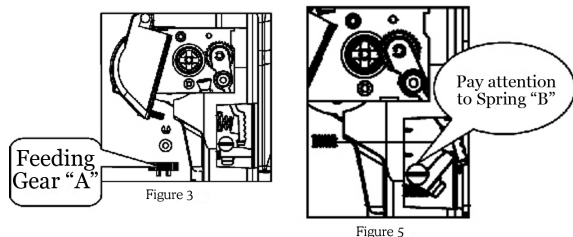

- Use a pair of pliers to remove the E-ring and washer on the feed gear as shown above. Remove gear.
- With a pair of pliers remove Spring “A” at the end of the release lever as shown above.
- Be careful not to drop the smaller Spring “B” at the other end of the release lever when you take out Spring “A” as shown above.

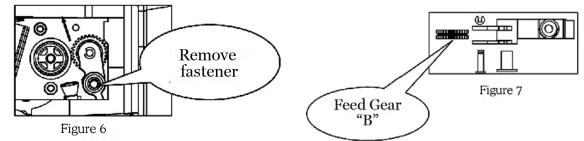

- Remove the hex screws of the release lever from the plate and take out the release lever in the direction of the arrow as shown above.
- After you remove the release lever you can remove the E-rings with pliers and the feeding gear “B” and then replace them.

After you finish replacing the gears all of the tool parts must be reassembled in reverse order.

- First install the release lever and fasten it.
- Install spring “B” and the latch lever. Fit Spring “A” at the end of the release lever
- Install the feeding gears, washer and E-ring in sequence
- Fix wire guide “C” on to the plate
- Finally attach the plastic cover with screws.

Care and Maintenance

- Perform a daily inspection prior to using this tool.
- Please maintain this electric tool carefully, making sure that the adjustments are correct and that it has been stored properly.
- Inspect the tool for damage and cracks in the housing and that the power supply is in good working order.
- Make sure that the battery charger is the one that came with your machine. Using another charger could cause damage to the battery and/or charger and could even cause a fire.
- Improper use of the battery could cause it to leak. If this happens it will need to be replaced and properly recycled. Do not touch any leaking material from this battery. If you come in contact with the battery liquid, flush with clean water and seek medical attention if necessary.
- When not in use, store this tool carefully in the supplied case. It can be washed with a soft cloth and soapsuds after you finish work. Do not use petroleum chemicals or alcohol to clean this tool.
- In the event that this tool malfunctions or drops in performance you can call our Customer Service Repair Center (800) 992-3833 or send us a note to mail@bnproducts.com.

Product Specifications and Technical Parameters

BNT-25X			mesh	#1	#2	#3	#4	#5
				1/8"	1/4"	3/8"	1/2"	5/8"
				6mm	8mm	10mm	13mm	16mm
mesh			x	x	x	x	x	x
#1	1/8"	6mm	x	x	x	x	x	x
#2	1/4"	8mm	x	x	x	x	x	
#3	3/8"	10mm	x	x	x	x	x	
#4	1/2"	13mm	x	x	x	x		
#5	5/8"	16mm	x	x				

BNT-40X			#1	#2	#3	#4	#5	#6	#7	#8	#9	#10
			1/8"	1/4"	3/8"	1/2"	5/8"	3/4"	7/8"	1"	1-1/8"	1-1/4"
			6mm	8mm	10mm	13mm	16mm	20mm	22mm	25mm	29mm	32mm
#1	1/8"	6mm			x	x	x	x	x	x	x	x
#2	1/4"	8mm		x	x	x	x	x	x	x	x	x
#3	3/8"	10mm	x	x	x	x	x	x	x	x	x	
#4	1/2"	13mm	x	x	x	x	x	x	x	x		
#5	5/8"	16mm	x	x	x	x	x	x	x			
#6	3/4"	20mm	x	x	x	x	x					
#7	7/8"	22mm	x	x	x	x	x					
#8	1"	25mm	x	x	x	x						
#9	1-1/8"	29mm	x	x	x							
#10	1-1/4"	32mm	x	x								
#11	1-3/8"	36mm										
#14	1-3/4"	43mm										
#18	2-1/4"	57mm										

BNT-58X			#3	#4	#5	#6	#7	#8	#9	#10	#11	#14	#18
			3/8"	1/2"	5/8"	3/4"	7/8"	1"	1-1/8"	1-1/4"	1-3/8"	1-3/4"	2-1/4"
			10mm	13mm	16mm	20mm	22mm	25mm	29mm	32mm	36mm	43mm	57mm
#1	1/8"	6mm						x	x	x	x	x	
#2	1/4"	8mm					x	x	x	x	x	x	
#3	3/8"	10mm				x	x	x	x	x	x	x	
#4	1/2"	13mm			x	x	x	x	x	x	x	x	
#5	5/8"	16mm		x	x	x	x	x	x	x	x		
#6	3/4"	20mm	x	x	x	x	x	x	x	x			
#7	7/8"	22mm	x	x	x	x	x	x					
#8	1"	25mm	x	x	x	x	x						
#9	1-1/8"	29mm	x	x	x	x	x						
#10	1-1/4"	32mm	x	x	x	x							
#11	1-3/8"	36mm	x	x	x								
#14	1-3/4"	43mm	x	x									
#18	2-1/4"	57mm	x										

Common Faults

This tool alerts you to the following fault conditions by means of a warning sound and warning light. If the problem is not solved please contact our maintenance support department: (800) 992-3833.

Common Faults	Warning Sound	Indicator Light	Items To Inspect	Possible Cause	Actions
The machine does not work after putting in a new wire spool.	None	Off	Inspect the battery terminal	Oxidation or there is dirt on the electrodes	Use a dry cloth to wipe the surfaces
	Beep----	On	Confirm that the battery is charged	Low power in the battery	Recharge the battery
	Beep, Beep, Beep	On Off On Off On off..	Check wire guide "A" to see if there is stray wire in the guide	The head of the wire was caught in the guide	Using a pair of pliers remove the wire
	Beep, Beep, Beep, Beep...	On Off On Off On off..	Check the curl guide to see if there is a stray wire caught in the tool	Tying strength may be too strong	Adjust the tying force and remove the caught wire
The wire does not feed correctly	Beep, Beep	On Off On Off On off..	Check the curl guide	The curl guide is open	Close the curl guide
	Beep, Beep, Beep	On Off On Off On off..	Check the diameter of the rebars	The diameter of the rebar exceeds chart	Use the proper diameter rebars
	Beep, Beep, Beep, Beep...	On Off On Off On off..	Check the tightness of the wire coil	The wire is too tight on the coil	Clear the wire
Irregular binding and wire stepping out of the curl guide	None	On-	Alarm when pressing the trigger-- No alarm when released	Overheated motor from constant use	Let the motor cool down
Failure to cut the wire after binding	None	On-	Check if the wire hits the rebar when tying	The wire hitting the rebar will stop the action	Pay attention so that the wire does not hit the rebar
Tying knot is loose	None	On-	Check to see if the cutting mechanism is working correctly	There may be a stray piece of wire in the cutting mechanism	Clean the cutting mechanism
	None	On-	Check the operation instruction	Wrong operation	Please read the operation manual
Tying knot is not correct	None	On-	Check the tying strength	The tying force is too great	Adjust to the proper tying force

BNT-40X Rebar Tier

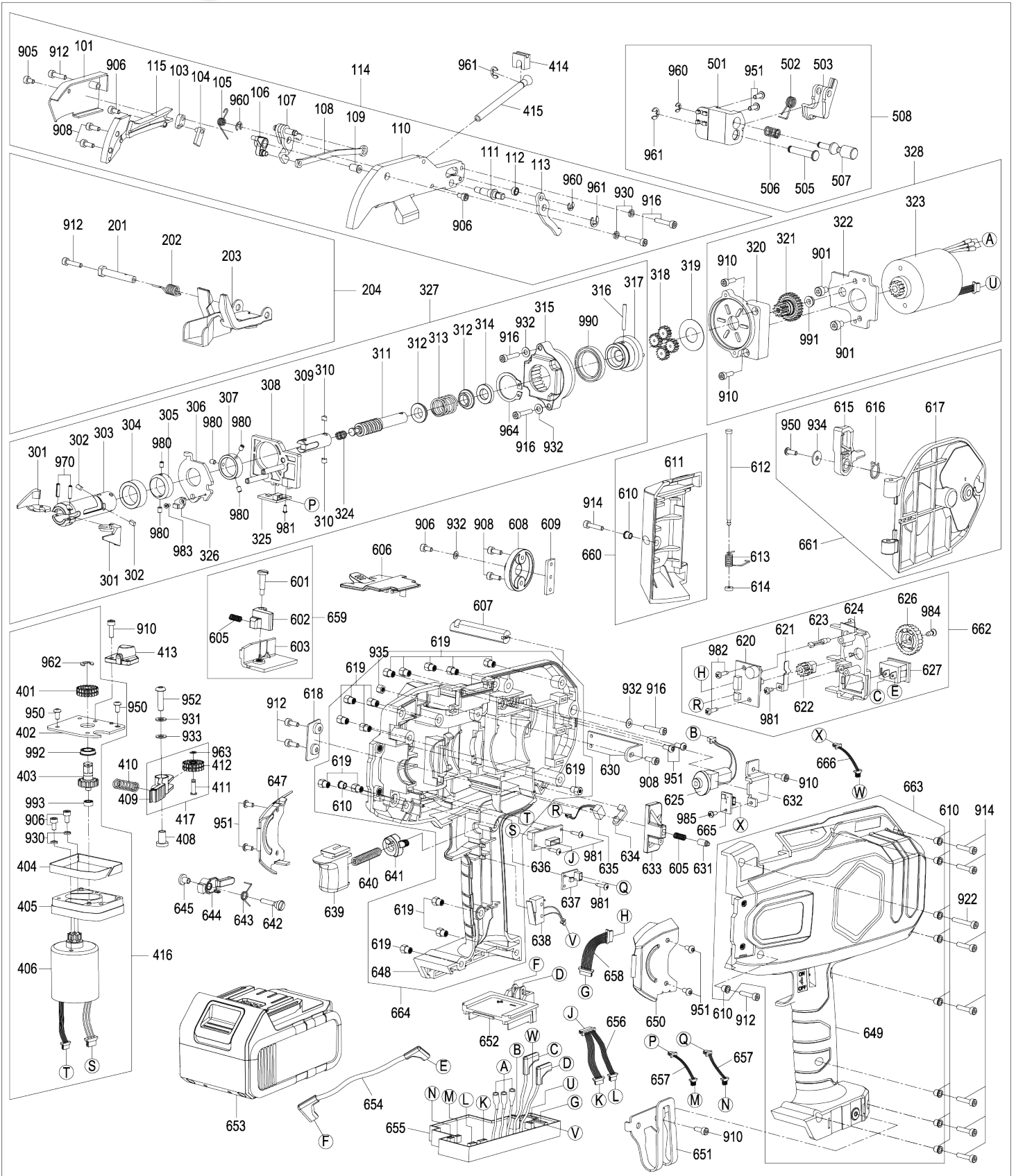

PARTS LIST BNT-40X		
Part	Description	Qty.
101	Arm A	1
103	Connecting Plate 1	1
104	Fixed Cutter	1
105	Torsion Spring 1	1
106	Cutter	1
107	Cutter Lever A	1
108	Connecting Rod 1	1
109	Cutter Sleeve	1
110	Arm A unit	1
111	Shaft Screw	1
112	Washer 4	1
113	Cutter Lever C	1
114	Arm A Unit Assy	1
115	Wire Guide A	1
201	Stopper Shaft	1
202	Torsion Spring 3	1
203	Curl Guide	1
204	Curl Guide Assy	1
301	Hook	2
302	Key A	1
303	Sleeve A	1
304	Sleeve Guide	1
305	Cutting Ring Guide	1
306	Cutting Plate	1
307	Cutting Ring Washer	1
308	Tip Axis Guide Assy	1 12.4g
309	Tip Axis B	1
310	Key B	2
311	Tip Axis A	1
312	Pin 1	2
313	Comp. Spring 2	1
314	Bumper	1
315	Internal Gear	1
316	Pin 5	1
317	Planet Gauge Unit	1
318	Planet Gear	4
319	Gear Press Wheel	1
320	Twisting Motor Gearbox	1
321	Sun Gear Unit	1
322	Motor Fixing plate	1
323	Twisting Motor Unit	1 256.5g
324	Comp. Spring 1	1

PARTS LIST BNT-40X		
Part	Description	Qty.
325	Route PWB Unit	1 1g
326	Magnetic Plate	1
327	Twister Assy	1 191.6g
328	Twisting Motor Assy	1 326.8g
401	Feeding Gear B1	1
402	Partition Plate	1
403	Feeding Gear Shaft	1
404	Dust-Proof strip	1
405	Feeding Motor Gearbox	1
406	Feeding Motor Unit	1 157.4g
408	Hollow Pin 1	1
409	Release Lever	1
410	Comp. Spring 3	1
411	Step Pin 1	1
412	Feeding Gear B2 1	
413	Wire Guide C	1
414	Rubber Base	1
415	Pipe	1
416	Feeding Motor Assy	1 206.8g
417	Release Lever Assy	1
501	Reel Press D 1	
502	Torsion Spring 7	1
503	Reel Press A	1
505	Reel Press Centre Axis	1
506	Torsion Spring 7	1
507	BN Reel Press limit Axis	1
601	Step Pin 2	1
602	Release Stopper	1
603	Reel Stopper	1
605	Comp. Spring 4	2
606	Window	1
607	Joint Reel Magazine	1
608	Reel Guide	1
609	Fixing Plate 1	1
610	Hollow Pin 7	11
611	Motor Cover	1
612	Step Pin 3 2	
613	Torsion Spring 5	1
614	Rubber Washer	2
615	Reel Stopper	1
616	Torsion Spring 6	1

PARTS LIST BNT-40X		
Part	Description	Qty.
617	Reel Stay	1
618	Strength Plate	1
619	Nut M3	15
620	Adjusting PWB Unit	1 3.8g
621	Adjusting Spring	1
622	Joint Knob	1
623	LED Unit	1
624	Adjusting Plate	1
626	Adjusting Knob	1
627	Main Switch Unit	1 3.8g
630	Fixing Plate 2	1
631	Jaw Pin	1
632	Brake Motor Platen	1
633	Jaw	1
634	Socket Cap	1
635	Socket	1 0.8g
636	Feeding PWB unit	1 2.4g
637	Sensor PWB D Unit	1 1g
638	Trigger Switch	1 3g
639	Trigger Switch 1	
640	Comp. Spring 5	1
641	Trigger Lock	1
642	Bolt	1
643	Torsion Spring 4	1
644	Switch Lever	1
645	Pin 4	1
647	Cover L Unit	1
648	Frame L	1
649	Frame R	1
650	Cover P Unit	1
651	Belt Hook	1
652	Electrode Unit	1 23.4g
653	18V Li-ion Battery	1 583.6g
654	Battery Connecting Wire	1 5.2g
655	Main PWB Unit	1 93.5g
656	Feeding Motor Connecting Wire	1 2g
657	Sensor Connecting Wire	2 0.5g
658	Adjusting Connecting Wire	1 1.5g
659	Reel Stopper Assy	1
660	Motor Cover Assy	1
661	Reel Stay Assy	1

PARTS LIST BNT-40X		
Part	Description	Qty.
662	Main Switch Base Assy	1 26.8g
663	Frame R Assy	1
664	Frame L Assy	1
665	Feeding-Response PWB unit	1
666	BN Cam Connecting Wire	1
901	Hex Bolt M4X6	2
904	Hex Bolt M3X4	2
905	Hex Bolt M3×5	1
906	Hex Bolt M3×6	5
908	Hex Bolt M3×8	5
910	Hex Bolt M3×10	6
912	Hex Bolt M3×12	5
914	Hex Bolt M3×14	8
916	Hex Bolt M3×16	5
922	Hex Bolt M3×22	1
930	Spring Washer φ3	4
931	Spring Washer φ4	1
932	Washer	4
933	Washer 2	1
934	Washer 3	1
935	Nut M3 (T4)	1
950	Button Head Screw M3X6	3
951	Button Head Screw M3X8	8
952	Button Head Screw M4X20	1
960	E-ring 3	3
961	E-ring 4	2
962	E-ring 5	1
963	E-Ring 2	1
964	C-ring 20	1
970	Spring Pin φ2.5	2
980	Hex Screw M3×4	5
981	Pan-head Screw ST2.2×6	5
982	Pan-head Screw ST3×8	2
983	Countersunk screw M2×4	1
984	Countersunk Scew M3×10	1
985	Pan-head Countersunk screw M2×4	1
990	Bearing 1	1
991	Bearing 2	1
992	Bearing 3	1
993	Bearing 4	1



The BNT-Series are hand-held battery operated tools. In this manual you will learn that these machines consists of four parts: the machine body, special wire coil, battery box and a charger. The tool is designed to be used for the fast tying of rebar or steel used in construction sites for the building trades. Due to its speed, convenience and safety, this machine can save a great deal of valuable labor and material resources. In addition, the parts and components as well as advanced production technologies are made from well-known manufacturers both here and abroad. This machine was developed as an economical and practical tying machine with many international patents.



BN Products-USA
3450 Sabin Brown Road
Wickenburg, AZ 85390
(800) 992-3833 • mail@bnproducts.com

