



**WACKER
NEUSON**

all it takes!

Operator's Manual

Vibration Plate

BPS



Machine Type
Material Number
Version
Date
Language

BPS1030, BPS1135, BPS1340
5100060589
2
07/2021
[us]



5 1 0 0 0 6 0 5 8 9

Imprint

Publisher and copyright holder:

Wacker Neuson Produktion GmbH & Co. KG

Wackerstraße 6

85084 Reichertshofen,

Registered office: Reichertshofen

Register court and number: Local Court Ingolstadt, HRA3195

VAT ID No./VAT Number: DE277138620

Telephone: +49 (0) 8453-3403200

Original operator's manual

All rights reserved, in particular the copyright, the right of reproduction and the right of distribution applicable worldwide.

This document may be used by the recipient only for the designated purpose. It may in no way be duplicated or translated in any other language, in whole or in part, without prior permission in writing from the manufacturer.

Reproduction or translation of this publication, in whole or part, is not permitted without the written consent of Wacker Neuson Produktion GmbH & Co. KG.

Violations of legal regulations, in particular of the copyright protection, will be subject to civil and criminal prosecution.

Wacker Neuson Produktion GmbH & Co. KG reserves the right to change its products and their technical specifications for further technical development at any time without any claim to changes to machines already delivered. The information in the technical documentation supplied with the product applies in each case.

The machine on the cover is for illustration purposes only and may therefore have special equipment (options).

Wacker Neuson Produktion GmbH & Co. KG, responsibility for errors or omissions not accepted, printed in Germany

Copyright © 2021

California Proposition 65 Warning



▲ WARNING

The engine exhaust from this product contains chemicals known to the State of California to cause cancer, birth defects, or other reproductive harm.



▲ WARNING

Diesel engine exhaust and some of its constituents are known to the State of California to cause cancer, birth defects, and other reproductive harm.



▲ WARNING

Cancer and Reproductive Harm
www.P65Warnings.ca.gov



▲ WARNING

Batteries, battery posts, terminals and related accessories contain lead and lead compounds, and other chemicals known to the State of California to cause cancer and birth defects or other reproductive harm. WASH HANDS AFTER HANDLING.



Contents

1	EC Declaration of Conformity	
2	Foreword	
2.1	Introduction	7
2.2	Storage Location of the Operator's Manual	7
2.3	Accident Prevention Regulations	8
2.4	Contact person	9
2.5	Limitation of liability	9
2.6	Use of the operator's manual	9
3	Usage	
3.1	Designated use	10
3.2	Unintended use	10
4	Safety	
4.1	Safety symbols and signal words	11
4.2	Principle	11
4.3	Structural changes	12
4.4	Responsibility of the operator	12
4.5	Obligations of the operator	13
4.6	Qualification of staff	13
4.7	General safety instructions	13
4.8	Specific safety instructions for vibration plates	15
4.9	Safety features	16
4.10	Maintenance	17
5	Description of the Machine	
5.1	Type plates and labels	19
5.2	Components	21
5.3	Control elements	22
6	Transportation	
6.1	Safety instructions for transport	23
6.2	Prerequisites and preparations	23
6.3	Lifting the machine	23
6.4	Lashing the machine	25
7	Commissioning	
7.1	Safety instructions for operation	26
7.2	Tests before commissioning	27
7.3	Putting into operation	27
8	Operation	
8.1	Operating the machine	30
8.2	Taking the machine out of operation	30

9	Maintenance	
9.1	Safety instructions for maintenance.....	31
9.2	Maintenance plan.....	32
9.3	Maintenance work.....	33
10	Troubleshooting	
10.1	Troubleshooting machine.....	38
11	Shutdown	
11.1	Temporary decommissioning.....	39
11.2	Final shutdown.....	39
12	Accessories	
12.1	Accessories.....	40
13	Technical Data	
13.1	General instructions.....	42
13.2	Noise and vibration data.....	42
13.3	BPS.....	42
13.4	Combustion engine.....	45
13.5	Conversion table.....	46



EU Declaration of Conformity

Manufacturer

Wacker Neuson Produktion GmbH & Co. KG, Wackerstraße 6, D-85084 Reichertshofen
This declaration of conformity is issued under the sole responsibility of the manufacturer.

Product	BPS1030, BPS1135, BPS1340
Product type	Vibratory rammer
Function of product	Soil compaction
Material number	5100058916, 5100059657, 5100059658, 5100059659, 5100059882, 5100059906, 5100060129
Net installed power	2,6 kW
Measured sound power level	104 dB(A)
Guaranteed sound power level	105 dB(A)

Conformity assessment procedure
2000/14/EC, Annex VIII

Notified body

TÜV Rheinland LGA Products GmbH, Tillystr. 2, D-90431 Nürnberg (NB 0197)

Guidelines and standards

We hereby declare that this product complies with the relevant provisions and requirements of the following directives and standards:

2006/42/EC, 2000/14/EC, 2014/30/EU, EN 500-1:2006 + A1:2009, EN 500-4:2011, EN ISO 13788-1:2018, EN ISO 13788-2:2018

Person responsible for technical documents

Wacker Neuson Produktion GmbH & Co. KG, Wackerstraße 6, D-85084 Reichertshofen

Reichertshofen, 02.07.2021

Helmut Bauer
Managing Director

2 Foreword

2.1 Introduction

This operator's manual contains important information and procedures for the safe, proper and economical operation of this machine. Careful reading, understanding and observing it helps to avoid hazards, reduce repair costs and downtimes and thus increase the availability and service life of the machine.

This operator's manual is not a manual for extensive maintenance or repair work. Such work must be carried out by the service partner or by technically trained personnel. The machine must be operated and maintained in accordance with the instructions in this operator's manual. Improper operation or maintenance can cause hazards.

Defective machine parts must be replaced immediately!

The manufacturer is always available to answer questions on operation or maintenance.

2.2 Storage Location of the Operator's Manual

This operator's manual must be kept in the immediate vicinity of the machine and accessible to personnel at all times.

If this operator's manual is lost or you require a new copy, there are two ways of obtaining a replacement:

2.2.1 Understanding These Instructions

This section helps to understand the operator's manual and the illustrations used therein.



Target group

People working with this machine must be regularly trained with regard to the dangers and risks occurring when using this machine.

This operator's manual is aimed at:

- Operating personnel:
 - These people have been instructed in working with the machine and about possible dangers and risks arising due to improper behavior.
- Technically trained personnel:
 - These people have a professional training as well as additional knowledge and experience. They are capable of assessing the tasks assigned to them and recognizing any possible risks and dangers.

Explanation of symbols

Symbol	Explanation
1., 2., 3...	Indicates an activity. The sequence of the steps must be observed.
→	Indicates a result or an intermediate result of an action.
✓	Indicates prerequisites that must be established for the activity.
•	Indicates a list, e.g. if several components are named one after the other.
-	Indicates a sub-list, e.g. if components consist of further components
ⓘ	Identifies a position, usually a component or control element, in a graphic. The numbering may be sequential or in Roman numerals.
1; A	Indicates the naming of components in explanatory texts. It is identical with the adjacent positions in the illustrations.
 	Indicates a direction of movement or different positions for switches.
▶	Indicates the avoidance of hazards in warning notices.
[+52]	Indicates a cross-reference in tables. Here e.g. reference to page 52.

2.2.1.1 Explanation of symbols

The symbols used in the operator's manual are explained below. The symbols are used exclusively in warning or environmental instructions or information. Warnings must always be observed to protect the operator and third parties from personal injury and damage to property.



Symbol for warning notices

This symbol marks general warnings. It is used to alert you of possible hazards, e.g. risks of injury or accidents.



Symbol for indications of technical damage

This symbol is a warning symbol that indicates a danger of technical damage. It is used to indicate situations where damage to the machine or third-party property may occur.



Symbol for environmental information

This symbol indicates environmental information. It is used to warn of possible environmental hazards.



Symbol for information

This symbol indicates information. This information can include tips on operation, for example. It helps to better understand and use the machine.

2.3 Accident Prevention Regulations

In addition to the notes and safety instructions in this operator's manual, the local accident prevention regulations and the national industrial safety regulations apply.

2.4 Contact person

Depending on the country, the contact person is a service partner, a sub-sidiary or a dealer.

2.5 Limitation of liability

In the event of the following infringements, the manufacturer disclaims any liability for personal injury and damage to property:

- Actions contrary to this operator's manual.
- Non-designated use
- Deployment of untrained personnel.
- Use non-approved spare parts and accessories.
- Improper handling.
- Structural changes of any kind.
- Non-observance of the General Terms and Conditions (GTC).

2.6 Use of the operator's manual

This operator's manual:

- must be regarded as an integral part of the machine and must be kept in a safe place throughout its service life.
- must be passed on to each subsequent owner or operator of this machine.
- applies to various machine types from one product range. For this reason, some illustrations may differ from the appearance of the purchased machine. Variant-dependent components that are not included in the scope of delivery can also be described.

The manufacturer reserves the right to change the information in this operator's manual without notice.

It must be ensured that any changes or additions made by the manufacturer are immediately incorporated into this operator's manual.

Group - Type	Material number (Mat. no.)
BPS1030Aw	5100058916
BPS1135Aw	5100058857
BPS1340Aw	5100058859
BPS1030A	5100058858
BPS1135A	5100058862
BPS1340A	5100058906
BPS1340Aws (Loxam)	5100060129

3 Usage

3.1 Designated use

Designated use also includes observing all notes and safety instructions in this operator's manual and observing the prescribed care and maintenance instructions.

The machine is used for:

- *Compaction in earth and gravel construction.*
- *Compaction of mixed and granular soils.*
- *Compaction of asphalt.*
- *Shaking in cobblestones.*

Any other use or use that goes beyond this is considered improper use. The manufacturer shall not be liable or liable for any damage resulting therefrom. The risk is borne solely by the operator.

3.2 Unintended use

The manufacturer is not liable for personal injury or damage to property resulting from unintended use. The following activities, among others, are not intended:

- *Compaction of strongly cohesive soils.*
- *Compaction of frozen soils.*
- *Compaction of hard, non-compactable soils.*
- *Compaction of non-load-bearing soils.*

4 Safety

4.1 Safety symbols and signal words

The following symbol identifies safety instructions. It is used for warning against potential personal risk or danger.



▲ DANGER

DANGER identifies a situation causing death or serious injury if it is not avoided.

Consequences in case of non-observance.

- ▶ Avoidance of injury or death.



▲ WARNING

WARNING identifies a situation that can cause death or serious injury if it is not avoided.

Consequences in case of non-observance.

- ▶ Avoidance of injury or death.



▲ CAUTION

CAUTION identifies a situation that can cause injury if it is not avoided.

Consequences in case of non-observance.

- ▶ Avoidance of injury.



NOTICE

INFORMATION identifies a situation that causes damage if it is not observed.

Consequences in case of non-observance.

- ▶ Avoidance of damage to property.

4.2 Principle

The machine has been designed and built in accordance with latest state-of-the-art standards and the recognized safety regulations. Nevertheless, improper use may result in danger to life and limb of the operator, third parties or damage to the machine and other material property.

Read and observe the notes and safety instructions in this operator's manual. Failure to follow these instructions may result in electric shock, fire and/or serious injury, and damage to the machine and/or other objects.

Keep safety instructions and information for the future.

4.3 Structural changes

Structural modifications may not be made without the written consent of the manufacturer. Unauthorized structural changes may result in hazards to the operator and/or third parties as well as damage to the machine.

The manufacturer's liability and warranty are also void in the event of unauthorized structural alterations.

In particular, a structural change shall be deemed to have occurred:

- When opening of the machine and permanent removal of components.
- Installation of spare parts that do not come from the manufacturer or are not equivalent in design and quality to the original parts.
- Attachment of accessories of any kind that do not originate from the manufacturer.

Spare parts or accessories from the manufacturer can be installed or re-moved safely.

4.4 Responsibility of the operator

The operator is the person who operates this machine himself for commercial or economic purposes or who leaves it to a third party for use/application and bears the legal product responsibility for the protection of personnel or third parties during operation.

The operator must make the operator's manual accessible to the personnel at all times and ensure that the operator has read and understood the operator's manual.

The operator's manual must be kept ready to hand at the machine or at the place of use.

The operator must hand over the operator to any other operator or subsequent owner of the machine.

The country-specific regulations, standards and directives on accident prevention and environmental protection must also be observed. The operator's manual must be supplemented by further instructions for compliance with operational, official, national or generally applicable safety guidelines.

4.5 Obligations of the operator

- Know and implement applicable health and safety regulations.
- In a risk assessment, identify hazards arising from working conditions at the place of use.
- Create operating instructions for the operation of this machine.
- Regularly check whether the operating instructions correspond to the current status of the regulations.
- Clearly regulate and define responsibilities for installation, operation, troubleshooting, maintenance and cleaning.
- Train personnel at regular intervals and inform them about possible dangers.
- Refresh instruction at regular intervals.
- Keep records of the training received and make them available to the competent authority on request.
- Provide personnel with the necessary protective equipment.

4

4.6 Qualification of staff

This machine may only be put into operation and operated by trained personnel.

In the event of misuse, abuse or operation by untrained personnel, there is a danger to the health of the operators and/or third parties, as well as damage or total failure of the machine.

In addition, the following requirements apply to the operator:

- Physical and mental suitability.
- Minimum age 18 years.
- No influence on reactivity by drugs, alcohol or medication.
- Familiarity with the safety instructions in this operator's manual.
- Familiarity with the intended use of this machine.
- Instructed in the independent operation of the machine.

4.7 General safety instructions

The safety instructions in this chapter contain the "General safety instructions", which must be listed in the operator's manual in accordance with the applicable standards. It may contain instructions which are not relevant for this machine.

4.7.1 Workplace

- Before starting work, familiarize yourself with the working environment, e.g. load-bearing capacity of the floor or obstacles in the environment.
- Secure work area to public transport area.
- Necessary protection of walls and ceilings, e.g. in trenches.
- Keep unauthorized persons and children away when working with this machine. Distraction may result in loss of control of the machine, work must be carried out carefully.
- Always secure the machine against tipping, rolling, slipping and falling. Risk of injury!
- Keep work area tidy. Disorder or unlit work areas can lead to accidents.
- Observe the changing ground conditions, especially on uneven and soft ground or on slopes. Secure the machine against slipping!
- When working near pits, ditches or plateaus, exercise caution! The load-bearing capacity of the ground must safely carry the weight of the machine and the operator.

4.7.2 Personal safety

- Working under the influence of drugs, alcohol or medication can lead to serious injuries.
- Suitable protective equipment must be worn for all work. Personal protective equipment considerably reduces the risk of injury.
- Keep wide or loose clothing, protective gloves, jewelry and long hair away from moving machine parts. Danger of being drawn in!
- Always ensure that you are standing in a stable position, always stand with both feet on the ground.
- During prolonged work with this machine, long-term vibration-related damage cannot be ruled out completely. Vibration load, see [Technical Data](#) on page 42.
- Ensure that there are no other persons in the danger zone!

Personal protective equipment



▲ WARNING

Risk of hearing damage if the country-specific noise limit is exceeded!

Working with the machine without hearing protection can lead to hearing damage in the long-term.

- ▶ Wear ear protectors.
- ▶ Work attentively and cautiously when using hearing protection.

4.7.3 Handling and use

- Handle machines with care. Do not operate machines whose components or control elements are defective. Have defective components or control elements replaced immediately. Machines with defective components or control elements entail a high risk of injury!
- Do not lock, manipulate or alter the machine operating elements in an inadmissible manner.
- Secure unused machines against unauthorized putting into operation. The machine may only be operated by authorized personnel.
- Handle machine with care. Have defective parts replaced immediately before this machine is commissioned. Defective machines entail a high risk of injury.
- Use the machine, accessories, tools etc. in accordance with these instructions.
- After operation, store the machine in a locked, clean, frost-protected, and dry location that is inaccessible to other persons and children.

4

4.8 Specific safety instructions for vibration plates

4.8.1 External influences

Do not operate the machine under the following external influences:

- In case of heavy rain on inclined surfaces. Danger of slipping!
- In potentially explosive atmospheres. Explosion hazard!
- If methane gas escapes from the ground in the vicinity of oil fields. Explosion hazard!
- In dry, highly flammable vegetation. Fire hazard!
- In the vicinity of open flames. Fire hazard!

4.8.2 Operational safety

- When operating the machine, make sure that no gas, water or electrical lines or pipes are damaged.
- Exercise the utmost degree of caution near abysses or slopes. Danger of falling!
- Do not leave the designated operating position when the machine is in operation.
- In trenches and pits, pay maximum attention to side walls so that they remain stable and do not collapse due to vibration. Risk of spillage!
- Never let the machine run unattended. Risk of injury!
- Keep work area clear and keep unauthorized persons away. Risk of injury!
- Operators of this machine must ensure that persons staying in the work area maintain a minimum distance of 2 metres from the running machine.
- When operating the machine on inclined surfaces, always approach gradients from below and always stand above the machine on the slope. The machine could slip or tip over.

4.9 Safety features

4.8.2.1 Safety distances

Compaction work in the vicinity of buildings can lead to building damage. Therefore, any possible effects and vibrations on surrounding buildings must be checked in advance.

The relevant regulations and codes of practice for measuring, assessing and reducing vibration immissions must be observed, in particular DIN 4150-3.

The manufacturer shall not be liable for any damage to buildings.

4.9 Safety features

Safety features protect the operator of this machine from being exposed to the existing hazards. These are barriers (separating protective devices) or other technical measures that serve to avert or reduce hazards.



▲ CAUTION

Hot exhaust!

Contact may cause burns.

- ▶ Only operate the machine if the safety features are correctly fitted.
- ▶ Do not change or remove safety devices.



The V-belt guard 1 protects the operator against crushing and entrapment.

4.10 Maintenance

- Do not service, repair, adjust or clean the machine when it is switched on.
- Observe maintenance intervals according to maintenance plan. Have work that is not listed performed by a service partner.
- Replace worn or damaged machine parts immediately. Only use spare parts from the manufacturer.
- Keep the machine clean.
- Replace any missing, damaged or illegible safety labels immediately. Safety and information labels contain important information for the protection of the operator.
- Carry out maintenance work in a clean and dry environment (e.g. workshop).

4.10.1 Service

- Only have the machine repaired or serviced by technically trained personnel.
- Only use original spare parts and accessories. The operational safety of the machine is thus maintained.

4.10.1.1 Threaded fittings

All threaded fittings must comply with the specified specifications and be firmly bolted together. Observe the tightening torques! Screws and nuts must not be damaged, bent or deformed.

Particular attention should be paid to the following:

- Self-locking nuts and micro-encapsulated screws must not be reused after loosening. The fastening effect is lost.
- Threaded fittings with adhesive protection/liquid adhesives (e.g. Loctite) must be cleaned after loosening and provided with new adhesive.



Information

Observe the instructions of the liquid adhesive manufacturer.

4.10.2 Vehicle fluids

- Always wear protective goggles and gloves when handling vehicle fluids. Seek medical advice immediately if, for example, hydraulic oil, fuel, oil or coolant gets into the eyes.
- Avoid direct skin contact with vehicle fluids. Wash skin immediately with soap and water.
- Do not eat or drink while working with vehicle fluids.
- Contaminated vehicle fluid (e.g. with dirt, water) can lead to premature wear or failure of the machine.
- Dispose of discharged or spilled vehicle fuel in accordance with applicable environmental regulations.
- If vehicle fluids leak from the machine, stop operating the machine and have it repaired immediately by a service partner.

4.10.3 Combustion engine



▲ WARNING

Danger of poisoning!

Inhalation of exhaust fumes can lead to death in a few minutes. Exhaust gases contain carbon monoxide.

- ▶ Do not operate the machine in a closed area, e.g. a tunnel.
- ▶ Unless there is adequate ventilation through exhaust fans or hoses.

- Before start of work, check the engine for leaks and cracks in the fuel line, tank and filler cap.
- Do not start the defective engine. Replace damaged parts immediately.
- The preset engine speed must not be adjusted. This could lead to engine damage.
- Ensure that the exhaust system of the engine is free of flammable materials. Fire hazard!
- Before refueling, switch off the engine and let it cool down.
- Use the correct type of fuel. Observe the prescribed mixing ratios.
- Use clean filling aids for refueling. Do not spill fuel, wipe up spilled fuel immediately.
- Do not start the engine near spilled fuel. Explosion hazard!
- When operating in partially enclosed rooms, sufficient ventilation must be provided. Do not inhale exhaust gas. Hazard of poisoning!
- The engine surface and exhaust system can become very hot after only a short time. Hazard of burning!
- Do not use jump start sprays. These can cause misfiring and engine damage. Fire hazard!
- Smoking prohibited!

5 Description of the Machine

5.1 Type plates and labels

5.1.1 Type label

A type label is permanently attached to the machine.

Other type labels

Furthermore, the following components of the machine are provided with their own type label:

- the combustion engine

Symbols on the type label

Various symbols and markings for national and international approvals may be shown on the type label.

5.1.1.1 Labeling on the machine

Type label data

The type label contains information that uniquely identifies this machine. This information is required for ordering spare parts and for technical queries.

Enter the data on the machine in the following table:

Designation	Your details
Group - Type	
Material number (Mat. no.)	
Machine version (version)	
Machine number (machine no.)	
Year of construction	

5.1.2 Safety and information labels



▲ WARNING

Injury hazard due to missing or damaged labels and signs!

Safety labels contain important information to protect the operator.

- ▶ Keep all safety, warning and operating instructions on the machine in a clearly legible condition.
- ▶ Replace missing or damaged labels and signs immediately.

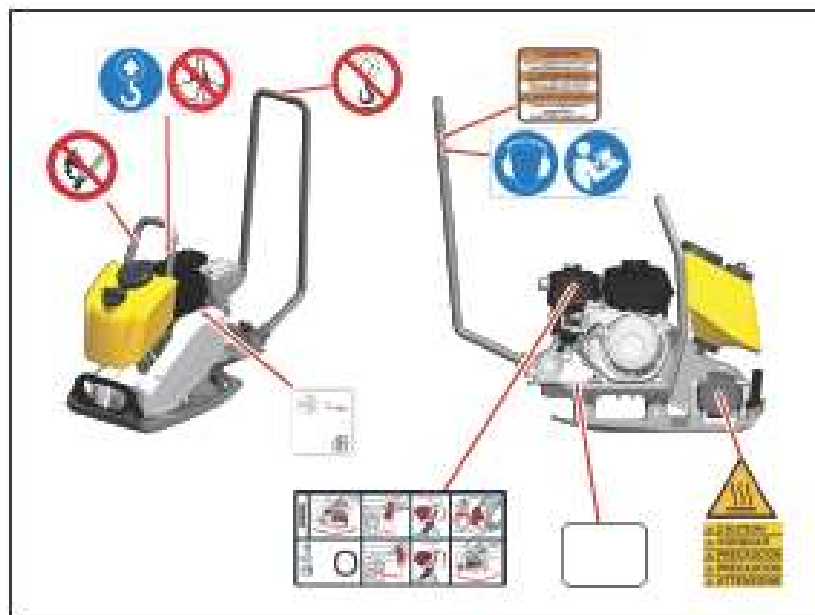

Caution!



Warning of health risks

WARNING! CALIFORNIA: Proposition 65 (Safe Drinking Water and Toxic Enforcement Act of 1986)

For more information: www.P65Warnings.ca.gov



Fire hazard!

Smoking and open fire prohibited.



No lifting point.



Risk of injury from falling machine

- Only lift at the lifting point.
- No lifting with an excavator bucket.



Wear personal protective equipment to avoid injury and health problems.

- Use hearing protection.
- Read the operator's manual.



Risk of burns!

Warning of hot surface.



Check oil and fuel levels.

Start / stop brief instructions.



Guaranteed sound power level.

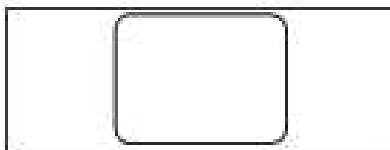

Type label.

5.2 Components



- 1 Water tank
- 2 Central suspension
- 3 Fuel tank
- 4 Drive motor
- 5 V-belt with V-belt guard
- 6 Rubber-metal buffer
- 7 Exciter
- 8 Base plate

5.3 Control elements

Always keep the displays and controls of the machine dry, clean and free of oil and grease.

Do not lock, manipulate or alter the machine operating elements in an inadmissible manner.

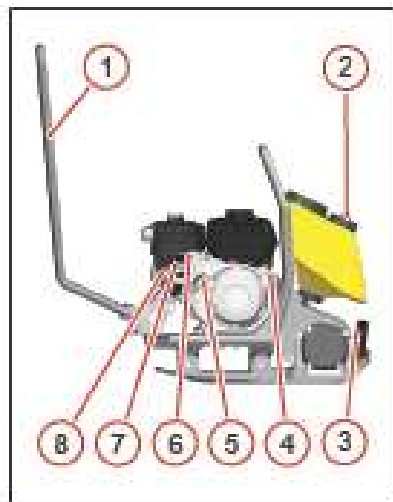

- 1 Guide bracket
- 2 Water sprinkling regulation
- 3 Handle
- 4 Engine switch
- 5 Handle reversing starter
- 6 Throttle lever
- 7 Choke lever
- 8 Fuel cock

6 Transportation

6.1 Safety instructions for transport



▲ WARNING

Hazard of falling!

The falling machine can cause serious injuries, e.g. by crushing.

- ▶ Only use suitable and tested lifting gear and slings (safety hooks) with sufficient lifting capacity.
- ▶ Only lift the machine by the central suspension.
- ▶ Secure the machine safely to the lifting gear.
- ▶ Do not lift the machine by the guide bracket.
- ▶ Leave the danger zone when lifting, do not stand under suspended loads.



▲ WARNING

Fire hazard due to fuel!

Leaking fuel can catch fire and cause severe burns.

- ▶ Empty the fuel tank before transport.

6

6.2 Prerequisites and preparations

- Switch off the machine and let it cool down.
- Use only suitable hoists with sufficient lifting capacity.
- Only use suitable lifting equipment with sufficient lifting capacity, see [Technical Data on page 42](#).
- The transport vehicle must have a sufficient bearing load and a suitable loading surface.

6.3 Lifting the machine

Lifting with lifting device and lifting gear



▲ WARNING

Risk of crushing!

If the machine is unstable, the lifting gear and the hoist may fail and fall down.

- ▶ Check the stability of the lifted machine before continuing work.

1. To ensure safe lifting, appoint a competent instructor.
2. Only use certified lifting and fastening gear.

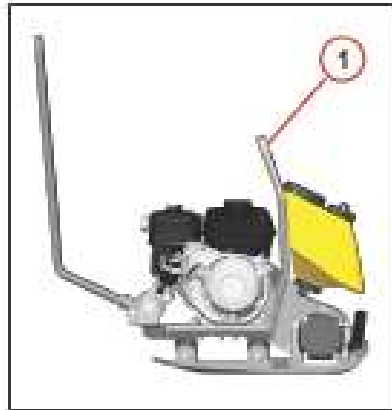

3. Attach suitable sling to central suspension 1.
4. Load the machine into or onto the transport vehicle.



5. Fold down the guide bracket 2 during transport.



▲ CAUTION

Danger of burns due to hot surfaces!

The machine, engine and exhaust can heat up quickly after a short time; that can lead to severe burns in case of contact with skin.

- ▶ Always allow the machine, engine and exhaust to cool down after use.
- ▶ Use heat-resistant protective gloves if the cooling phase cannot be maintained (e.g. due to an emergency).

Lifting by the handles

1. Designate at least one second person for a safe lifting operation.
2. Two persons should hold and lift the machine at the provided handles with both hands.
3. Load the machine into or onto the transport vehicle.

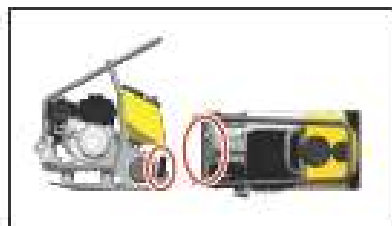

6.4 Lashing the machine



NOTICE

Use anti-slip mats to secure the load.



Only use the lashing points provided for this purpose to secure the machine.

- Tie down the machine as shown.
- ⇒ The machine is secured against unrolling, slipping and tipping over.

7 Commissioning

7.1 Safety instructions for operation



▲ WARNING

Tipping hazard due to slipping or overturning machine!
 At least 2/3 of the machine must be on a stable surface near edges.

- ▶ Take the machine out of operation and lift it back onto a stable surface.



▲ WARNING

Improper handling may result in injury or serious material damage.

- ▶ Please read and follow all safety instructions in this operator's manual.



▲ CAUTION

Health hazard due to vibrations!
 Physical impairments due to vibration.

- ▶ Take regular breaks.



▲ CAUTION

Risk of collapse and spillage!
 There is a risk of injury from falling or spilling when working on fracture, pit, dump and embankment edges, on trench edges and heels.

- ▶ Pay attention to side walls and their stability.
- ▶ Ensure stability.

Operation on inclined surfaces



NOTICE

Technical damage due to failure of engine lubrication!

- ▶ Do not exceed the maximum permissible inclination, see [see Technical Data on page 42](#).
- Only approach gradients from below.

Ground conditions

The maximum dumping height depends on several factors of the ground conditions. An exact specification of this value is not possible.

- Determine the maximum fill height by compaction tests or soil samples.

Shaking in cobblestones

- To avoid damage to the machine or compaction material, use a sliding device, see [Accessories](#) on page 40.

Compaction of asphalt

- To avoid cracking and sticking to the asphalt, use water tank with sprinkler system, see [Accessories](#) on page 40.

7.2 Tests before commissioning



Information

Further information and detailed descriptions, see [Maintenance](#) on page 31.

Perform the following checks:

- Check machine and components for damage.
 - Do not put the damaged machine into operation. Damages and defects must be repaired immediately.
- Check the fuel level.
- Check fuel lines for leaks.
- Check air filter.
- Check engine oil fill level.
- Check reversing starter.
- Check to ensure the screw connections are firmly seated.
- Check control elements for functionality.

7

7.3 Putting into operation



▲ WARNING

Danger of burns due to starting aid sprays!

Starting aid sprays can ignite and cause severe burns.

- ▶ Do not use any starting aid sprays.

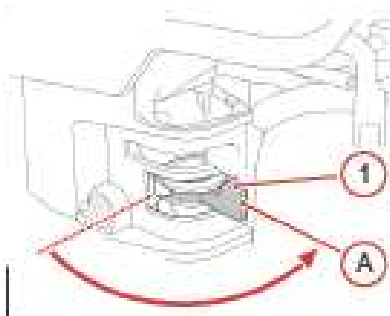

1. Move the fuel cock 1 into position A.

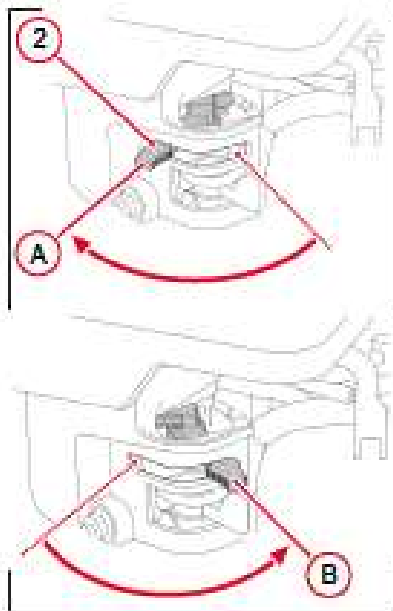

2. Move choke lever 2 to position A when the engine is cold.
3. Move the choke lever to position B when the engine is warm.

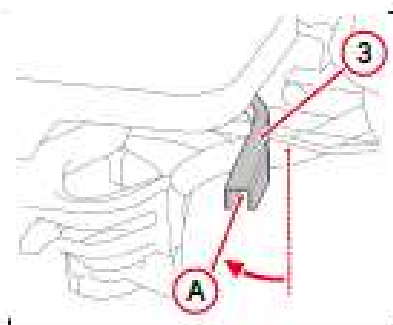

4. Move the throttle lever 3 into position A.

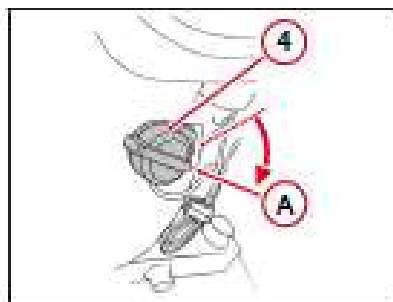

5. Move the engine switch 4 into position A.

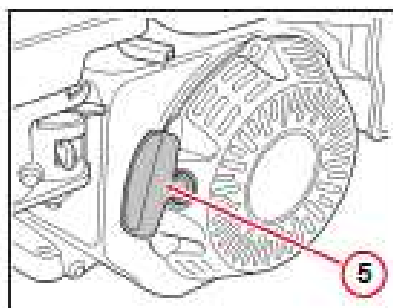

6. Pull the starting handle 5.
 ⇒ Pull the starting handle slightly until resistance is felt, then pull it strongly. Slowly return the starting handle.

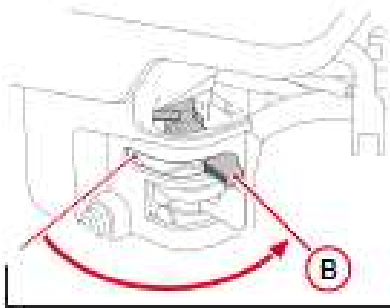

7. Move choke lever to position A for starting, move choke lever back to position B while the engine is warm.
⇒ Engine runs.

8 Operation

8.1 Operating the machine

The operator's designated location is behind the machine.

Guide and steer the machine using the guide bracket.

8.2 Taking the machine out of operation

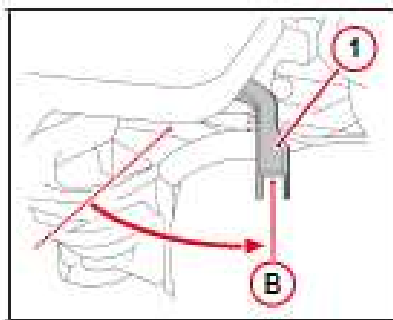

1. Move the throttle lever 1 to position B.

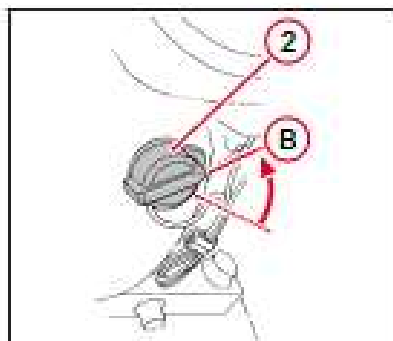

2. Move the engine switch 2 into position B.

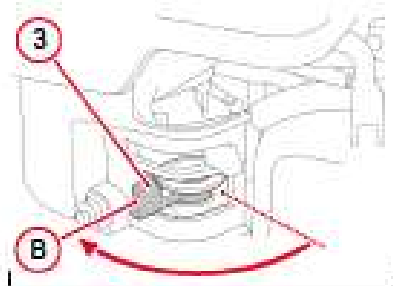

3. Move the fuel cock 3 into position B.
⇒ Let the machine and engine to cool down.

9 Maintenance

9.1 Safety instructions for maintenance



▲ WARNING

Improper handling may result in injury or serious material damage.

- ▶ Please read and follow all safety instructions in this operator's manual.



▲ WARNING

Hazard of poisoning from exhaust fumes!

Exhaust fumes contain poisonous carbon monoxide, which can lead to unconsciousness or to death.

- ▶ Only perform maintenance work with the engine switched off and the machine decommissioned.



▲ WARNING

Risk of injury from uncontrolled machine starting and moving parts!

- ▶ Only perform maintenance work with the engine switched off and the machine decommissioned.



▲ WARNING

Fire and explosion hazard due to fuel and fuel vapors!

Fuel and fuel vapors can ignite or catch fire and cause serious burns.

- ▶ Do not smoke.
- ▶ Do not refuel near open fire.
- ▶ Switch off the engine and allow it to cool before refueling.



▲ WARNING

Risk of fire and explosion when using flammable cleaning agents!

- ▶ Do not clean the machine and components with gasoline or other solvents.



▲ WARNING

Burn hazard due to hot engine oil!

Splashes of hot oil can cause burns to the skin.

- ▶ Switch off the engine and let it cool down.
- ▶ Use protective gloves.



▲ WARNING

Risk of injury due to missing or non-functioning safety devices!

- ▶ Only operate the machine if the safety devices are correctly installed and functioning.
- ▶ Do not change or remove safety devices.



▲ CAUTION

Health risk from fuel, lubricants and coolants!

- ▶ Do not inhale vapors.
- ▶ Avoid skin and eye contact.



NOTICE

If the engine is operated without an air filter, there is a risk of faster engine wear!

- ▶ Do not operate the engine without an air filter or air filter cover.



Environment

Soil contamination due to oil leaking or overflowing.

- ▶ Line work surface with impermeable foil.
- ▶ Use collecting container for used oil.
- ▶ Dispose of used oil in an environmentally friendly manner in accordance with statutory regulations.



Environment

Avoid damage to the environment!

- ▶ Clean the machine in a suitable place where the dirty waste water can be collected in an environmentally friendly manner.
- ▶ Collect contaminated water and dispose of it in an environmentally friendly manner.

9.2 Maintenance plan



NOTICE

Danger of engine damage!

- ▶ When commissioning new machines, an oil change must be carried out once after 20 operating hours.

Maintenance work	daily	monthly	100 h	125 h	300 h	500 h
Clean the machine. • Visual check for completeness. • Visual check for damage.	•					
Check engine oil fill level.	•					
Check air filter intake area.	•					
Check screw connections.	•					
Clean fuel filter.	•					
Clean and check air filter.		•				
Check V-belt tension.		•				
Clean the deposit cup.			•			
Change engine oil.			•			
Check spark plugs.			•			
Check rubber buffer.*				•		
Check valve clearance.*					•	
Replace the fuel filter.						•

9.3 Maintenance work

Carrying out preparations:

1. Place the machine on a level surface.
2. Decommissioning the machine.
3. Let the machine cool down.

9

9.3.1 Cleaning the machine

Observe the following when cleaning the machine with a high-pressure cleaner:

1. Do not aim high-pressure cleaner directly at air intake area and electrical components.
2. Do not hold the high-pressure cleaner too close to the machine in order to avoid damage to labels and sensitive components.

Visual check after cleaning:

1. Check cables, hoses and lines for leaks and chafe marks.
2. Check screw connections.
⇒ Replace damaged components.
3. Check all safety, warning and operating instructions for completeness.
⇒ Replace missing or damaged labels and signs immediately.

9.3.2 Checking and topping up the fuel level

1. Remove dirt.
2. Open tank lid.
3. Check the fuel level.
⇒ Max. fuel level to lower edge of filler neck.
4. Refuel if necessary, see [Technical Data on page 42](#).
5. Close tank cap tightly.

9.3.3 Cleaning and checking the air filter

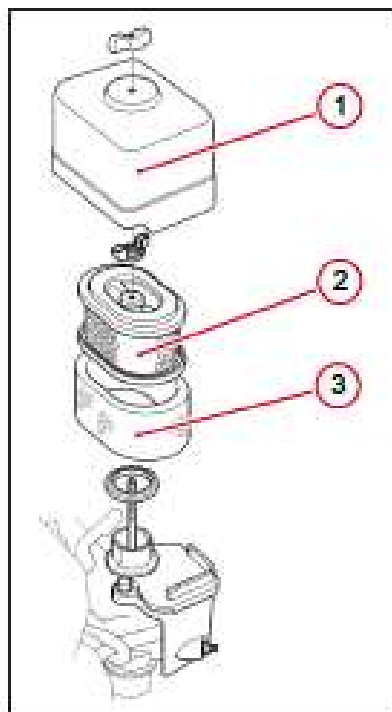

1. Remove air filter lid 1.
2. Remove and separate the air filter inserts.
⇒ Paper filter insert 2 and foam filter insert 3
3. Check both air filter inserts for cracks and holes, replace if damaged.

Cleaning the paper filter insert

1. Knock out filter insert on hard surface.
2. Blow with compressed air from the inside through the filter insert.
⇒ Do not brush out, this will force dirt into the fibers.
⇒ Replace if heavily soiled.

Cleaning the foam filter insert

1. Wash the filter insert in soapy water.
2. Rinse thoroughly with water.
3. Leave to dry.
4. Immerse in new engine oil, see [Technical Data on page 42](#).
5. Press out the filter insert.
⇒ Excess engine oil will smoke when the engine is started.

9.3.4 Checking and topping up engine oil level



NOTICE

Danger of engine damage!

- ▶ Only change the oil when the engine is at operating temperature.
- ▶ Only use engine oil with the correct specification, see [Technical Data on page 42](#).

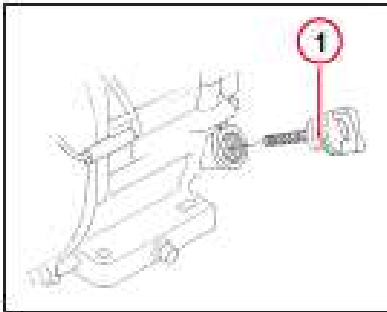

1. Remove dirt.
2. The machine must be horizontal.
3. Unscrew engine oil dipstick 1.
4. Wipe the engine oil dipstick with clean and fiber-free rags.

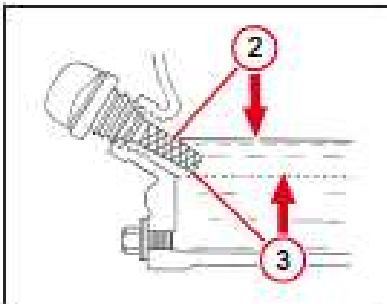

5. Insert the engine oil dipstick again.
6. Pull out the engine oil dipstick again.
7. Check engine oil fill level.
⇒ If the engine oil level is at the lower fill level limit 3, top up engine oil if necessary, see [Technical Data on page 42](#).
⇒ Fill engine oil to the upper fill level limit 2, do not overfill.
- Tighten the engine oil dipstick again.

9.3.5 Replacing engine oil

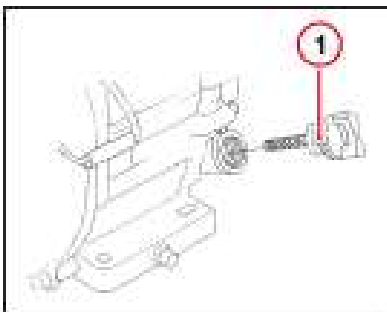

1. Remove dirt.
2. Provide a suitable container for draining the used oil.
3. Unscrew engine oil dipstick 1.



4. Unscrew the engine oil drain plug with sealing ring 2.
5. Allow the used oil to drain completely.
6. Tighten the engine oil drain plug with new sealing ring, tightening torque 18 Nm.
7. Place the machine in a horizontal position.
8. Fill in new engine oil, see [Checking and topping up engine oil level on page 34](#).
9. Tighten the engine oil dipstick again.

9.3 Maintenance work

9.3.6 Cleaning the deposit cup

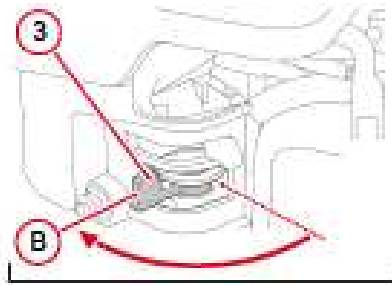

1. Move the fuel cock 3 into position B.

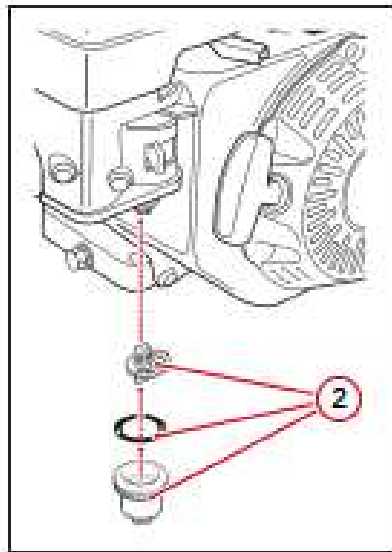

2. Remove deposit cup, filter and O-ring 2.
3. Clean and dry deposit cup and filter.
4. Replace the O-ring, filter and sedimentation cup.

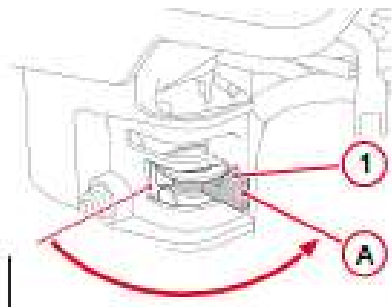

5. Move the fuel cock 1 into position A.
6. Check fuel system for leaks.

9.3.7 Checking spark plug

**NOTICE**

Danger of engine damage!

An incorrect spark plug can cause engine damage, see [Technical Data](#) on page 42.

- ▶ Correct electrode spacing.
- ▶ Free of deposits.

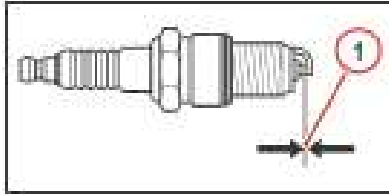

1. Pull out spark plug connector.
2. Remove dirt from the spark plug area.
3. Unscrew spark plug and check.
4. Replace if damaged or heavily soiled.
5. Measure electrode spacing 1, see [Technical Data](#) on page 42.
⇒ Correct the electrode spacing by carefully bending it.
6. Tighten the spark plug again, tightening torque 18 Nm.
7. Plug the spark plug connector onto the spark plug.

9.3.8 Retightening and changing the V-belt

Carrying out preparations:

1. Place the machine on a level surface.
2. Decommissioning the machine.
3. Let the machine cool down.

Tighten the V-belt

1. Remove the V-belt guard.
2. Unscrew the screws of the exciter V-belt pulley.
3. Remove outer V-belt pulley half.
4. Remove the intermediate pulley.
5. Align and secure the removed intermediate pulleys and the outer V-belt pulley half.



Information

When tightening, turn the V-belt pulley to prevent the V-belt from jamming.

1. Tighten the screws.
2. Fit the V-belt guard, tightening torque 10 Nm.

10 Troubleshooting

10.1 Troubleshooting machine



▲ WARNING

Danger to life due to unauthorized troubleshooting!

- ▶ If faults occur on this machine which are not described in these operating instructions, contact the manufacturer.
- ▶ Do not rectify faults on your own.

Fault	Possible cause	Remedy
The engine cannot be started.	Engine switch off.	Engine switch on.
	Throttle lever in stop or idle position.	Throttle lever on.
	Fuel cock is closed.	Open the fuel cock.
	Not enough fuel.	Refill with fuel. Check fuel filter and fuel lines.
	Incorrect valve clearance.	Check valve clearance, have it adjusted if necessary.*
	Valves worn.	Have the machine repaired.*
	Cylinder and/or piston ring worn.	
	Spark plugs worn.	
Engine oil level too low.	Add engine oil.	
No vibration when the engine is running.	V-belt worn.	Change V-belt.
	Clutch linings worn out.	Have the clutch linings replaced.*

* Have this work carried out by a service partner.

11 Shutdown

11.1 Temporary decommissioning



Information

Further information and detailed descriptions, see [Maintenance](#) on page 31.

Storage requirements

- Store dust-free and dry.
- Do not store outdoors.
- Protect from direct sunlight.
- Observe the storage temperature, see [Technical Data](#) on page 42.
- Store in a locked place that is not accessible to children.

If the machine is stationary for more than 1 month, perform the following measures:

Entire machine	<ul style="list-style-type: none"> • Clean thoroughly. • Check for leaks, rectify any defects if necessary.
Fuel tank	Plastic tank: <ul style="list-style-type: none"> • Drain fuel completely. Metal tank: <ul style="list-style-type: none"> • Refill with fuel.
Engine	<ul style="list-style-type: none"> • Check engine oil level, fill engine oil if necessary. • Check and clean air filter. • Clean fuel filter.
Components susceptible to corrosion	Oil and grease.

11.2 Final shutdown

If the machine is no longer in use and is shut down for good, all operating fluids must be drained.

Have the machine professionally dismantled and disposed of by a state-approved recycling company.

Professional disposal of this machine avoids negative effects on human health and the environment, helps with the targeted treatment of pollutants and makes it possible to recycle valuable raw materials.

12 Accessories

12.1 Accessories



▲ CAUTION

Risk of injury and possible machine damage!

Use of non-original spare parts or accessories can lead to injuries or machine damage.

- ▶ Only use original spare parts and accessories.
- ▶ In case of disregard, no liability will be accepted.



▲ CAUTION

Stability of the machine with wheel set!

Tipping over or rolling away of the machine can lead to injuries or material damage.

- ▶ Park the machine safely.
- ▶ Secure the wheel set against rolling away or fold it up.



Water tank

Water tank with continuously adjustable sprinkler system, see *Safety instructions for operation* on page 27.



Wheel set

Wheel set for easier transport on the construction site.

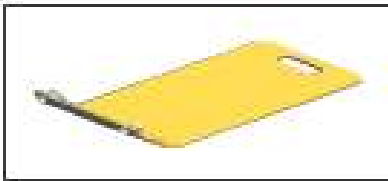

Slide mechanism

Surface protection, see Safety instructions for operation on page 27.

13 Technical Data

13.1 General instructions



Information

For system technical reasons, empty columns can be displayed in the technical data, and numbers and letters that written in superscript or subscript may be displayed incorrectly, e.g:

- ▶ Sound power level LWA instead of L_{WA}
- ▶ Sound pressure level LpA instead of L_{pA}
- ▶ Vibration total value ahv instead of a_{hv}
- ▶ Carbon dioxide CO2 instead of CO_2
- ▶ Unit m/s2 instead of m/s^2

13.2 Noise and vibration data

The noise and vibration data listed have been determined in accordance with the following guidelines for the typical machine operating conditions / special test conditions and using harmonized standards:

- Machinery Directive 2006/42/EC
- Noise Emission Directive 2000/14/EC

During operational use, values may differ depending on the prevailing operating conditions.

Sound pressure level at operator station

- L_{pA} was determined according to EN ISO 11201 and EN 500-4.

Guaranteed sound power level

- L_{WA} was determined according to EN ISO 3744 and EN ISO -4.

Weighted vibration total value hand-arm vibration

- a_{hv} was determined according to EN ISO 20843 and EN 500-4.

13.3 BPS

Type	BPS1030Aw	BPS1030A
Material number machine	5100058916	5100059658
Material number engine	5100045004	5100045004
Centrifugal force [kN]	10	10
Vibrations [Hz]	98	98
Vibrations [1/min]	5880	5880
Area output* [m ² /h]	500	500
Flow [m ³ /min]	28	28
Gradeability [%]	38.4	38.4
Length (drawbar in working position) [mm]	930	930

Type	BPS1030Aw	BPS1030A
Material number machine	5100058916	5100059658
Width [mm]	320	320
Height [mm]	663	663
Underclearance [mm]	663	663
Operating weight [kg]	56	53
Nominal power** [kW]	2.6	2.6
Rated speed [1/min]	3600	3600
Operating temperature range [°C]	-15 - +45	-15 - +45
Storage temperature range [°C]	-15 - +40	-15 - +40
Sound pressure level at operator station LpA [dB(A)]	94	94
Sound power level LWA, measured [dB(A) [*]	104	104
Sound power level LWA guaranteed [dB(A)]	105	105
Vibration total value ahv [m/s ²]	4.6	4.6
Measurement uncertainty of the total vibration value ahv [m/s ²]	0.5	0.5
*Depends on the soil conditions.		
** Corresponds to the installed net power according to Directive 2000/14/EC.		

Type	BPS1135Aw	BPS1135A
Material number machine	5100059657	5100059662
Material number engine	5100045994	5100045994
Centrifugal force [kN]	11	11
Vibrations [Hz]	98	98
Vibrations [1/min]	5880	5880
Area output* [m ² /h]	546	546
Flow [m ³ /min]	26	26
Gradeability [%]	36.4	36.4
Length (drawbar in working position) [mm]	930	930
Width [mm]	350	350
Height [mm]	663	663
Underclearance [mm]	663	663
Operating weight [kg]	63	61
Nominal power** [kW]	2.6	2.6
Rated speed [1/min]	3600	3600
Operating temperature range [°C]	-15 - +45	-15 - +45
Storage temperature range [°C]	-15 - +40	-15 - +40
Sound pressure level at operator station LpA [dB(A)]	93	93
Sound power level LWA, measured [dB(A) [*]	104	104
Sound power level LWA guaranteed [dB(A)]	105	105
Vibration total value ahv [m/s ²]	4.5	4.5
Measurement uncertainty of the total vibration value ahv [m/s ²]	0.5	0.5

Type	BPS1135Aw	BPS1135A
Material number machine	5100059657	5100059662
*Depends on the soil conditions.		
** Corresponds to the installed net power according to Directive 2000/14/EC.		

Type	BPS1340Aw	BPS1340A
Material number machine	5100059659	5100059906
Material number engine	5100045004	5100045005
Centrifugal force [kN]	13	13
Vibrations [Hz]	98	98
Vibrations [1/min]	5880	5880
Area output* [m ² /h]	624	624
Flow [m ³ /min]	28	28
Gradeability [%]	36.4	36.4
Length (drawbar in working position) [mm]	930	930
Width [mm]	400	400
Height [mm]	663	663
Underclearance [mm]	663	663
Operating weight [kg]	75	71
Nominal power** [kW]	2.8	2.8
Rated speed [1/min]	3600	3600
Operating temperature range [°C]	-15 - +45	-15 - +45
Storage temperature range [°C]	-15 - +40	-15 - +40
Sound pressure level at operator station LpA [dB(A)]	95	95
Sound power level LWA, measured [dB(A)*]	104	104
Sound power level LWA guaranteed [dB(A)]	105	105
Vibration total value ahv [m/s ²]	4.6	4.6
Measurement uncertainty of the total vibration value ahv [m/s ²]	0.5	0.5
*Depends on the soil conditions.		
** Corresponds to the installed net power according to Directive 2000/14/EC.		

Type	BPS1340Aws (Loxam)	
Material number machine	5100060129	
Material number engine	5100045005	
Centrifugal force [kN]	13	
Vibrations [Hz]	98	
Vibrations [1/min]	5880	
Area output* [m ² /h]	624	
Flow [m ³ /min]	28	
Gradeability [%]	36.4	
Length (drawbar in working position) [mm]	930	
Width [mm]	400	
Height [mm]	663	

Type	BPS1340Aws (Loxam)	
Material number machine	5100060129	
Underclearance [mm]	663	
Operating weight [kg]	71	
Nominal power** [kW]	2.6	
Rated speed [1/min]	3600	
Operating temperature range [°C]	-15 - +45	
Storage temperature range [°C]	-15 - +40	
Sound pressure level at operator station LpA [dB(A)]	95	
Sound power level LWA, measured [dB(A)¹]	104	
Sound power level LWA guaranteed [dB(A)]	105	
Vibration total value ahv [m/s²]	4.6	
Measurement uncertainty of the total vibration value ahv [m/s²]	0.5	
*Depends on the soil conditions.		
** Corresponds to the installed net power according to Directive 2000/14/EC.		

13.4 Combustion engine

Engine manufacturer	Honda
Material number engine	5100045894
Engine type	GX 120
Combustion processes	four-stroke
Cooling	Air
Cylinder	1
Cubic capacity [cm³]	118
Inclined position max. [°]	20
Fuel type	Gasoline
Fuel consumption [l/h]	1
Tank volume [l]	2,5
Oil specification	SAE 10W-30
Oil filling max. [l]	0,8
Output max. [kW]	2,6
RPM [1/min]	3600
Standard	SAE J1349
Exhaust-emission level	EU Stage V, US Phase 3
CO ₂ emission* [g/kWh]	978
Spark plug type	NGK BP-6 ES
Electrode gap [mm]	0,7 - 0,8
* Determined value of the CO ₂ emission during engine certification without consideration of the applications on the machine.	

13.5 Conversion table

Engine manufacturer	Honda
Material number engine	5100045995
Engine type	GX 160
Combustion processes	four-stroke
Cooling	Air
Cylinder	1
Cubic capacity [cm ³]	163
Inclined position max. [°]	20
Fuel type	Gasoline
Fuel consumption [l/h]	0,8
Tank volume [l]	3,6
Oil specification	SAE 10W-30
Oil filling max. [l]	0,6
Output max. [kW]	3,6
RPM [1/min]	3600
Standard	SAE J1349
Exhaust-emission level	EU Stage V, US Phase 3
CO ₂ emission* [g/kWh]	757
Spark plug type	NGK BP-6 ES
Electrode gap [mm]	0,7 - 0,8
* Determined value of the CO ₂ emission during engine certification without consideration of the applications on the machine.	

13.5 Conversion table

The following conversion tables enable the conversion of the metric values from the instructions, in particular the technical data, into the imperial.

Conversion table	
Volume units	
1 cm ³	0.061 in ³
1 m ³	35.31 ft ³
1 ml	0.034 US fl.oz.
1 l	0.26 gal.
1 l/min	0.26 gal./min
Length units	
1 mm	0.039 in
1 m	3.28 ft
Weights	
1 kg	2.2 lbs.
1 g	0.035 oz.
Pressure	
1 bar	14.5 psi
1 kg/cm ²	14.22 lbs/in ²
Force/output	

Conversion table	
1 kN	224.81 lbf
1 kW	1.34 hp
1 PS	0.986 hp
Torque	
1 Nm	0.74 ft.lbs
Speed	
1 km/h	0.62 mph
Acceleration	
1 m/s ²	3.28 ft./s ²



**WACKER
NEUSON**
all it takes!

Wacker Neuson Produktion GmbH &
Co. KG
Wackerstraße 6
D-85084 Reichertshausen

Tel.: +49 8453 340-0
Material Number: 5100060589
Language: [us]