

OWNERS MANUAL

MEDIUM CONCRETE SAWS



**MODEL:
C1320P**

FORM C1320P rev 9-2010

NORTON
clipper

WARRANTY

Norton warrants all products manufactured by it against defects in workmanship or materials for a period of one (1) year from the date of shipment to the customer.

The responsibility of Norton under this warranty is limited to replacement or repair of defective parts at Norton's Gainesville, Georgia factory, or at a point designated by it, of such part as shall appear to us upon inspection at such point, to have been defective in material or workmanship, with expense for transportation borne by the customer.

In no event shall Norton be liable for consequential or incidental damages arising out of the failure of any product to operate properly.

Integral units such as **gasoline engines, electric motors, batteries, tires, transmissions, etc.**, are excluded from this warranty and are subject to the prime manufacturer's warranty.

This warranty is in lieu of all other warranties, expressed or implied, and all such other warranties are hereby disclaimed.

Important: Before placing equipment in operation, record the following information.

MODEL: _____ **SERIAL NO.** _____

PURCHASE FROM: _____

ADDRESS: _____

CITY _____ **STATE** _____ **ZIP** _____

TELEPHONE NO. _____

Before using this equipment, make sure that any person using it reads and understands the instructions in this owner's manual.

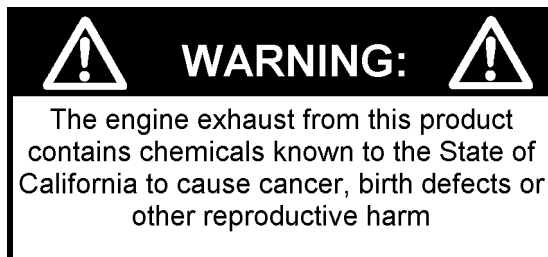

Table of Contents

CONTENTS	PAGE
Warranty Information	2
I. Preparation	
A. Safety Precautions	4-6
B. Assembly	7
C. Concrete Saw Specifications	8
II. Operation	
A. Blade Installation	9-11
B. Changing the Blade Side	12-14-
C. Engine Operation	12-14
D. Starting The Engine	14-16
E. Water Supply	16
F. Controls	17-18
G. Operating The Saw	18-19
H. Cutting Technique	19-20
I. Lead-Off Adjustment	20
III. Maintenance	
A. Engine	21-22
Engine Warranty	23
B. Bearings	24
C. V-Belts	25-26
D. Depth Control	26-27
G. Electrical Diagram 13HP Manual Start	28
IV. Parts List Section	
A. Ordering Information	29
Common Replacement Parts	29
B. Assembly Drawings/Service Parts Listing	30-43
Frame Common Group	30-31
Raise Axle Group	32-33
Blade Shaft and Engine Group	34-35
Blade Guard and Water System Group	36-37
Controls and Console Group	38-39
Depth Adjustment Group	40-41
Optional Water Tank Group	42-43
Contact Information	44



Read Owners Manual Before Use



Safety Alert Symbol: Information Following This Symbol Is Very Important.

I. PREPARATION

A. Safety Precautions

Important! The following safety precautions must always be observed.

Hazard Symbols



Fuel (gasoline) is extremely flammable and its vapors can explode if ignited. Store gasoline only in approved containers, in well-ventilated, unoccupied approved areas, and away from sparks or flames. Do not fill the fuel tank while the engine is hot or running. Do not start the engine near spilled fuel. Never use the fuel as a cleaning agent



Engine components can get extremely hot from operation. To prevent burns, do not touch the engine or related parts while the engine is running or immediately after it is turned off. Never operate the engine with any heat shields or guards removed.



Keep all guards in place when operating any piece of equipment



Keep hands, feet, hair, and clothing away from all rotating parts

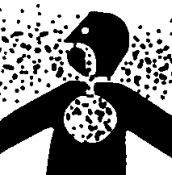

Lethal Exhaust Gas: use only in well ventilated areas. Engine exhaust gases contain poisonous carbon monoxide, which is odorless, colorless, and can cause death if inhaled. Avoid inhaling exhaust fumes, and never run the engine in a closed building or confined area.



Never tamper with the governor components of settings to increase the maximum speed. Severe personal injury and damage to the engine or equipment can result if operated at speed above maximum. Always obey the maximum speed rating of blade.



DO NOT LIFT THE SAW BY THE HANDLE BARS

WARNING

Dust and Silica Warning

Grinding/cutting/drilling of masonry, concrete, metal and other materials can generate dust, mists and fumes containing chemicals known to cause serious or fatal injury or illness, such as respiratory disease, cancer, birth defects or other reproductive harm. If you are unfamiliar with the risks associated with the particular process and/or material being cut or the composition of the tool being used, review the material safety data sheet and/or consult your employer, the material manufacturer/supplier, governmental agencies such as OSHA and NIOSH and other sources on hazardous materials and make certain to comply with all product warnings and instructions for the safe and effective use of the material being cut. California and some other authorities, for instance, have published lists of substances known to cause cancer, reproductive toxicity, or other harmful effects.

Control dust, mist and fumes at the source where possible. In this regard use good work practices and follow the recommendations of the manufacturer/supplier, OSHA/NIOSH, and occupational and trade associations. Water should be used for dust suppression when wet cutting is feasible. When the hazards from inhalation of dust, mists and fumes cannot be eliminated through engineering controls such as vacuum and/or water mist, the operator and any bystanders should always wear a respirator approved by NIOSH/MSHA for the material being cut.

Use Approved:



Eye Protection



Hearing Protection



Respiratory Protection



Head Protection

1. Before mounting any blade on the saw, the blade should be inspected for any damage which might have occurred during shipment, handling or previous use.
2. The blade collars and arbors should be cleaned and examined for damage before mounting the blade.
3. The blade must be properly fitted over the arbor with the drive pin on the outside collar projecting through the drive pin hole on the blade and inside collar.
4. The blade shaft nut, which is a left hand thread nut, must be tightened securely against the outside blade shaft collar.
5. The blade must be operated within the specified maximum operating speed listed on the blade.
6. Turn water control valve to full to provide adequate coolant (5 to 8 gallons per minute) for diamond blades and wet cutting abrasive blades. Insufficient coolant could result in severe blade breakage or diamond segment separation.
7. The blade guard must be in place with the nose guard down and locked when the saw is running.
8. The operator should wear safety glasses and any other appropriate safety equipment.
9. When starting the saw, the operator should stand away and to the side of the blade.
10. If for any reason the saw should stall in the cut, raise the blade out of the cut. Check the outside blade shaft collar and nut for tightness. Inspect the blade for damage before restarting the saw. User caution when resuming a cut. Be certain that the blade is in alignment with the previous cut.
11. During cutting operations, do not exert excess side pressure on the handles as a method of steering. Do not force the blade into the cut by lowering the blade too fast or by pushing the saw too fast.



You Are Responsible For Your Safety!!!

I. PREPARATION

B. Assembly

The C1320P push concrete saws are shipped completely assembled and ready for use except for diamond blade, gasoline, oil, and handle bar. Inspect the saw for shipping damage. If any damage is found, contact the shipper immediately and file a freight claim. Norton Clipper is not responsible for any freight-related damages. Remove the saw from the pallet. Reverse the position of the handlebars so that the handle bar sticks out towards the operator. Adjust the handlebars to the desired height. Attach the handlebars to the saw with the supplied hardware. For electric start models fill and check the electrolyte level and charge the battery. Read and understand the remaining sections of this Owners Manual. NOTE: Do not install the blade until it is time to use the saw. ANSI regulations prohibit the transportation of any concrete saw with the blade installed.



DO NOT LIFT THE SAW BY THE HANDLE BARS

C. C1320P Concrete Saw Specifications

Dimensions/Weight	C1320P
Length (Transport)	56 inch (1142 mm)
Width	26 inch (660 mm)
Height	40 inch (1016 mm)
Weights	310 (141kg)
Engine	
Engine Mfg.	Honda
Model	GX390
Spec No.	GX390K1QXC9
Engine Type	Single Cylinder 4 Cycle
Horse Power*	13 hp (9.5kW) @ 3,600 rpm
Max Torque*	19.5 ft-lbs (26.5 Nm, 2.7 kgf-m) @ 2,500 rpm
Cooling System	Air
Oil Capacity	1.1 liter (1.16 US qt)
Fuel Capacity	6.5 liter (1.79 US gal)
Fuel Type	Unleaded Gasoline (86 pump octane)
Low Oil Sensor	Yes
Air Filtration	Four Stage Honda Cyclone
Start Type	Manual
Characteristics	
Max Blade	20" (356 mm)
Depth of Cut	
20" (356 mm)	7-1/2 inch (191 mm)
16" (305 mm)	5.50" (140 mm)
Arbor Bore	1 inch (25.4 mm)
Blade Shaft Locking Device	Machined Into Flats Of Tight Collar
Blade Shaft Speed	2600 rpm,
Depth Control	Hand Wheel With Screw Feed
Depth Lock	Standard
Number Of V-Belts	4
Blade Guard Type	Pivoting All Steel Construction
Right or Left Side Cutting	Standard
Lifting Bale	Built In
Handle Bars	Adjustable
Recessed Rear Wheels	Standard
Front Wheel	Wheel 5 x 2 x ¾ With Roller Bearing
Rear Wheel	Wheel 6 x 2 x ¾ With Roller Bearing
Water Hose Connector	Standard Garden Hose With Flow Control Valve
Sound pressure ¹	88 db(A)
Sound power ¹	105 db(A)

* = Horse power and Torque ratings are Gross Horse power and are supplied by the engine manufacturer. Actual output of the engine will vary due to many factors including operational speed of engine, environmental conditions, maintenance, fuel, and other variables. Saint-Gobain Abrasives, Inc. makes NO claim to actual or gross horse power and torque ratings. 1) The sound measures have been made following pr EN 12638, Annex A;

2) "Floor sawing, grooving and milling machines – Safety "

II. OPERATION



Read and understand this manual before running or using the machine!

A. Installing the Blade

1. Insure that the Ignition Power Key Switch is in the OFF position and then disconnect the spark plug.
2. Remove the blade shaft nut, (NOTE: Operator's Right side is a left hand thread and the Operator's Left side is right hand thread), and remove the outside collar. Rotate the Blade Guard to gain better access to the Blade Shaft Nut, Loose Collar, Blade, and Tight Collar. To Rotate the Blade Guard pull the Blade Guard Retaining Pin out away from the Blade Guard Frame Bayonet and the rotate the Blade Guard up and out of the way.

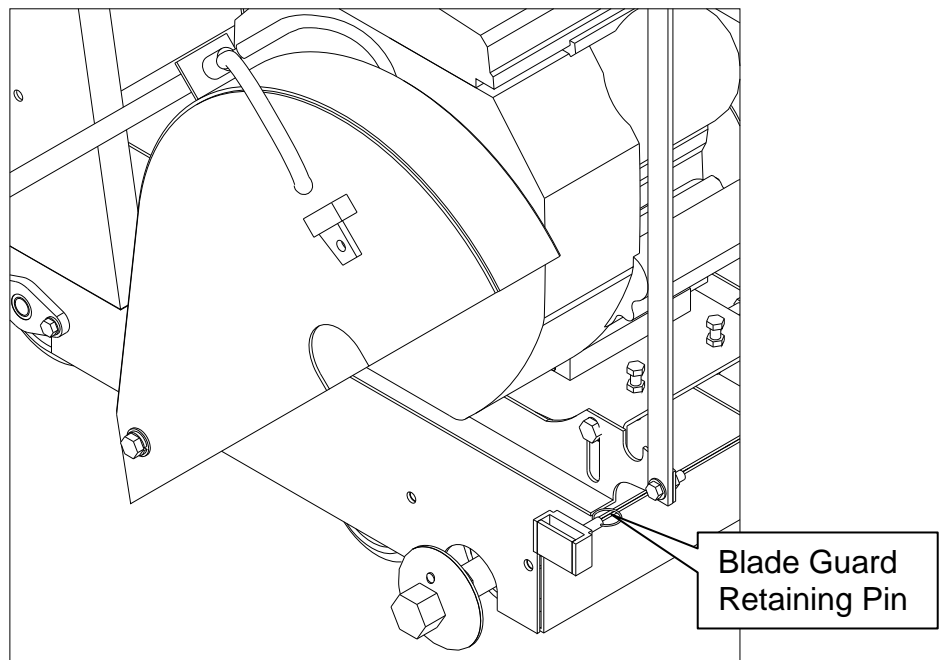

Blade Guard Retaining Pin with Guard Rotated for Access to Blade Shaft Nut and Collars

3. Clean off any foreign particles on the clamping surfaces of both collars and on the mounting surface of the blade and also inspect the drive pin for damage. Replace any damage collars or pins before using the machine.

4. Inspect the blade for any damage, cracks, burnt or blue areas, missing segments, and roundness of blade. Also inspect the arbor hole and drive pin hole to insure both are round. If any problems are found do not use the blade. In addition check that the blade is the correct specification for the application.



For Best Performance Use Only Norton Diamond Blades Specified For the Material Being Cut.

5. Place the blade on the blade shaft, lining up the drive pin hole in the blade with the drive pinhole in the inside collar. **NOTE:** Diamond blades are direction dependent so verify the direction of rotation of the blade. The machine will rotate the blade into the work surface (down cut). Place the blade guard in position and insert the blade guard retainer pin. Never operate the saw without the blade guard or blade guard retainer pin in position **See the following diagram *Blade Installation*.**

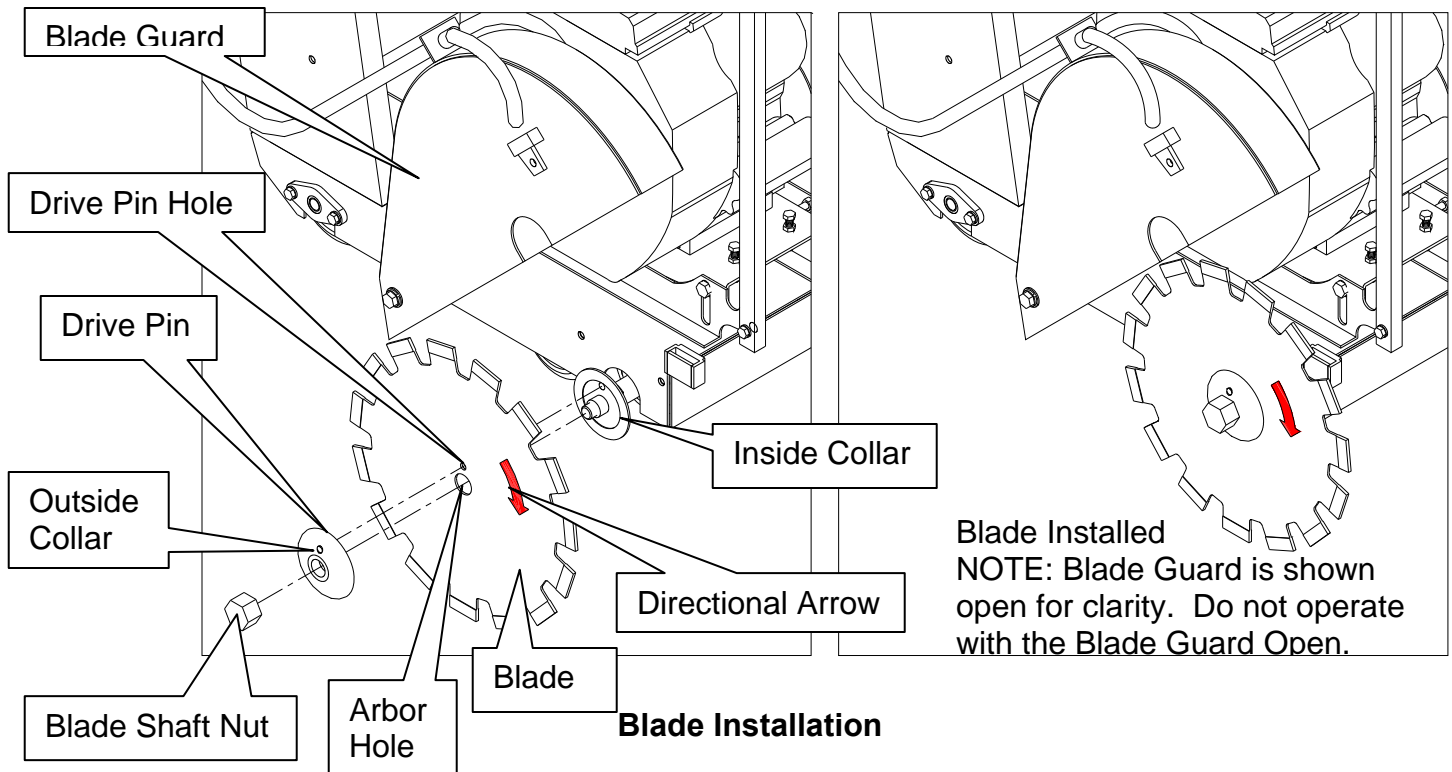

6. Slide the outside blade shaft collar onto the blade shaft. The drive pin on the outside collar must project through the drive pin hole in the blade and into the inside collar.

7. Tighten the blade shaft nut (counter-clockwise for the Operator's Right Hand side and clockwise for the Operator's Left hand side).
8. Insure that the Blade Guard is lowered and the Blade Guard Locking pin is secure. Close Blade Guard Nose. **See *Blade Installed* diagram below.**

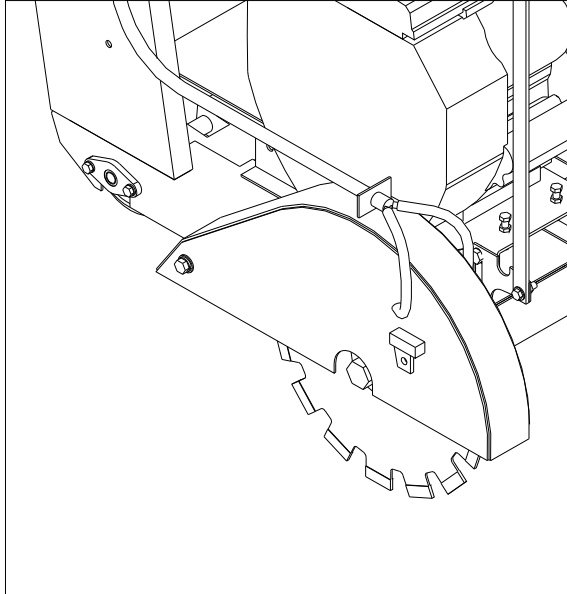

Blade Installed

9. Reconnect the spark plug.



Observe rotation arrow on blade and do not exceed maximum RPM stamped on blade.



NOTE: Organic bonded blades (A) must have a blotter. The blotter (B) must extend past the blade collar contact area as shown.

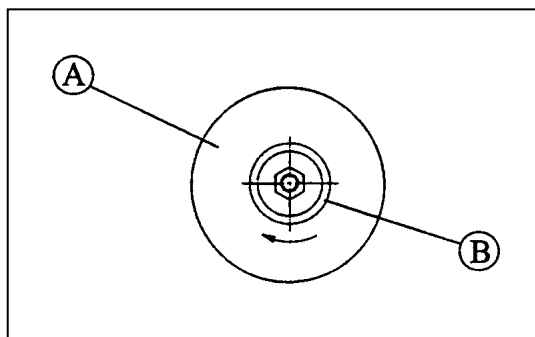

Blades Use Only Norton Diamond Blades

B. Changing the Blade Side:

1. Insure that the Ignition Power Key Switch is in the OFF position and then disconnect the spark plug.
2. Remove the blade shaft nut, (NOTE: Operator's Right side is a left hand thread and the Operator's Left side is right hand thread), and remove the outside collar.
3. Clean off any foreign particles on the clamping surfaces of both the outside and inside collars and on the mounting surface of the blade and inspect the both collars for any damage and also inspect the drive pin for damage. Reinstall the Blade Shaft Collars to the machine.
NOTE: Replace any damage collars or pins before using the machine.
4. Inspect the blade for any damage, cracks, burnt or blue areas, missing segments, and roundness of blade. Also inspect the arbor hole and drive pin hole to insure both are round. If any problems are found do not use the blade. In addition check that the blade is the correct specification for the application.
5. Remove the Blade Guard from the machine by unscrewing the Blade Guard Pivot Bolt from the rear of the Blade Guard. **NOTE:** Keep the $\frac{1}{2}$ " Flat Washer and $\frac{1}{2}$ " Lock Washer on the Bolt.

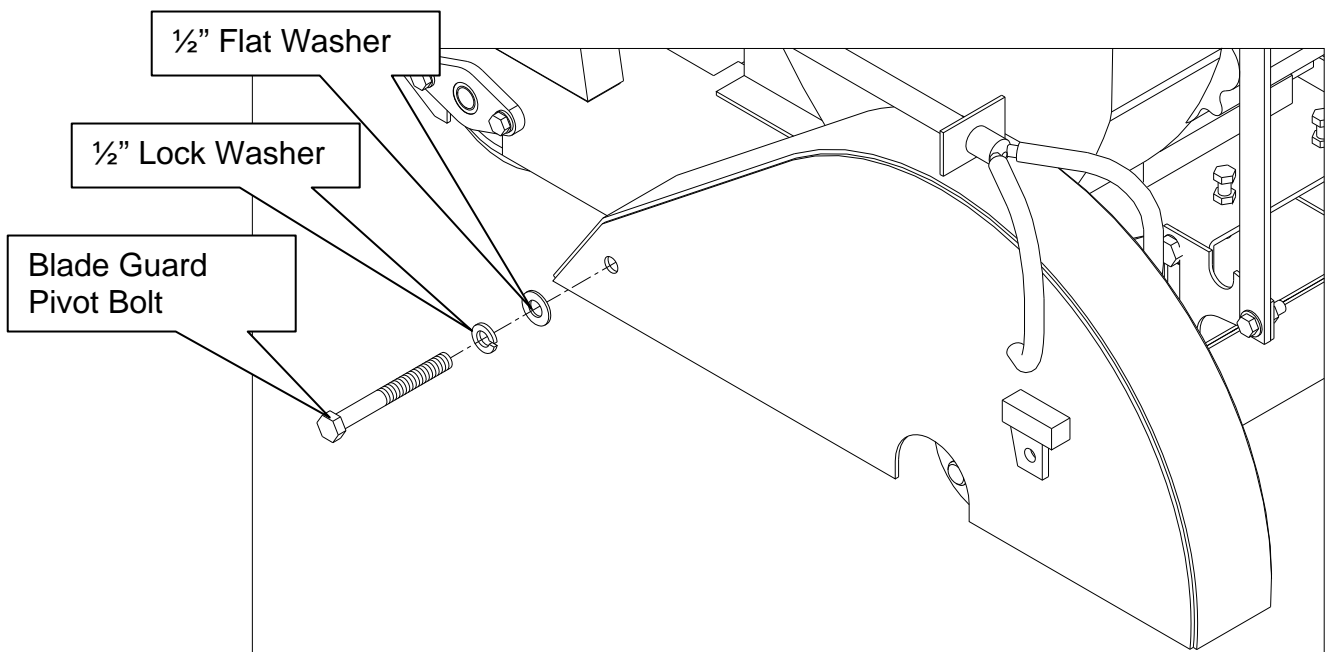

Blade Pivot Bolt Removal

6. Remove the Blade Shaft Guard by removing the Blade Shaft Guard retaining bolts. **See *Blade Shaft Guard Removal* diagram below.**

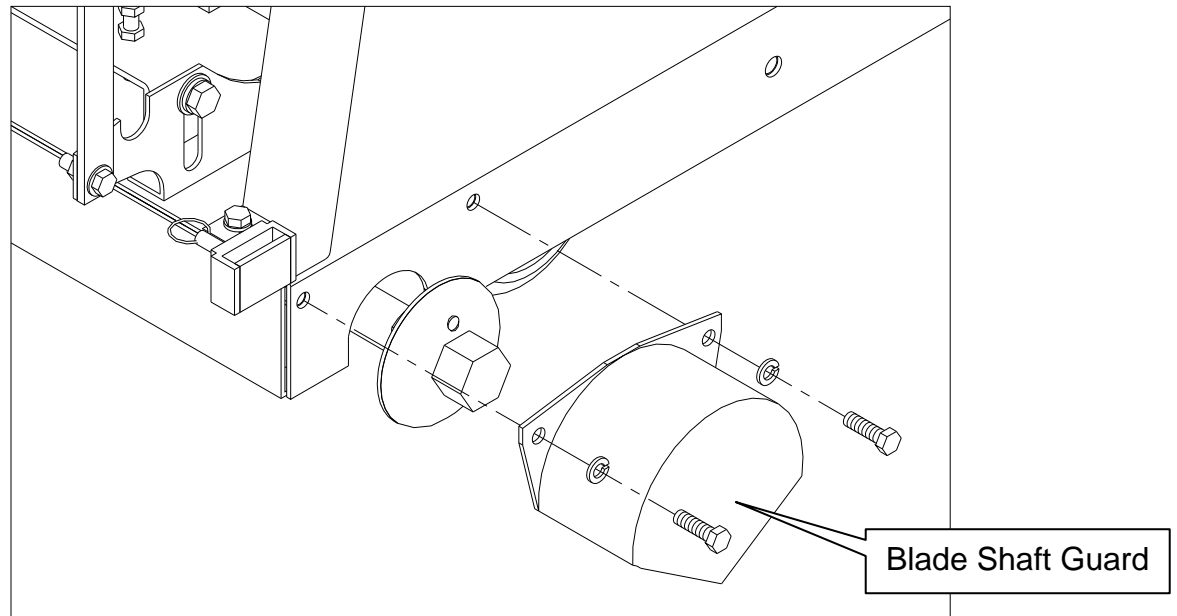

Blade Shaft Guard Removal

7. Place the blade on the blade shaft, lining up the drive pin hole in the blade with the drive pinhole in the inside collar. **NOTE:** Diamond blades are direction dependent so verify the direction of rotation of the blade. The machine will rotate the blade into the work surface (down cut).
7. Slide the outside blade shaft collar onto the blade shaft. The drive pin on the outside collar must project through the drive pin hole in the blade and into the inside collar.
8. Tighten the blade shaft nut (counter-clockwise for the Operator's Right Hand side and clockwise for the Operator's Left hand side).
9. Place the blade guard in position and insert and tighten the Blade Guard Pivot Bolt. Never operate the saw without the blade guard or blade guard retainer pin in position **See the diagram Blade Shaft Installation** on page 10 and **Blade Installed** on page 11.
10. Insure that the Blade Guard is lowered and the Blade Guard Locking pin is secure. Close Blade Guard Nose.
11. Attach the Blade Shaft Guard to the opposite side of the machine.

12. Remove the Pointer and reattach it to the Operators Left hand side of the machine. NOTE: Reverse the orientation of the Pointer
13. Reconnect the spark plug.

C. Engine Operation

Prior to attempting to operate the engine, read the information contained in the engine owner's manual. An engine owner's manual is supplied with every gasoline powered concrete saw.

1. **Check Oil:** Add oil if low. Refer to the engine owner's manual for the recommended SAE viscosity grades. Capacity of oil is 1.1 liters (1.16 US qt)
2. **Check Fuel:** Fill if low. Use only unleaded gasoline with a pump sticker octane rating of 86 or higher is recommended. **Never use an oil and gasoline mixture!**
3. **Air Cleaner:** Never run the engine without the air cleaner! Rapid engine wear will result from contaminants being drawn through the carburetor and into the engine.
4. **Engine Starting:** Refer to the engine owner's manual for detailed engine starting procedure.
5. **Engine Speed:** Always run the engine and the proper speed for the blade being used. Never run the blade at a higher speed that it is rated for. See the Blade Speed chart located on the machine's console or located in the manual under the heading "Operating the Saw"
6. All 13 HP units are equipped with a Choke control attached to the Engine below the Air Cleaner on the Operator's Right Hand Side.



D. Starting the Engine

1. Refer to the engine owner's manual for detail starting procedures.
2. Always cut with engine rpm in the full throttle setting.



Before starting, insure that the blade is properly installed, all guards are in place and in safe operating condition, and that the Blade is not in contact with any surface or object. Also verify that the area where the work is to be preformed is clean, safe, and has proper ventilation and lighting. Always located and properly mark all water, gas, and electrical services before beginning any work.

Locate and under stand the functions of the: Engine Fuel Control Valve (Located on the Engine under the Air Cleaner), Choke Control (Located On the Engine under the Air Cleaner), ON/OFF Switch (located on the Operator's Left Side Top of the Console), and Throttle Control (located on the Operator's Left Side Top the Console). SEE Section F. Controls for Details on the locations and operation of the machines controls before operating.

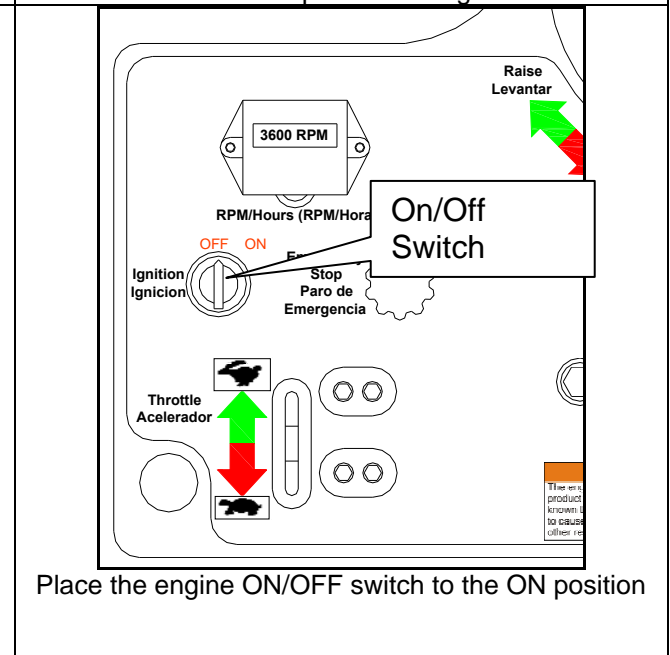
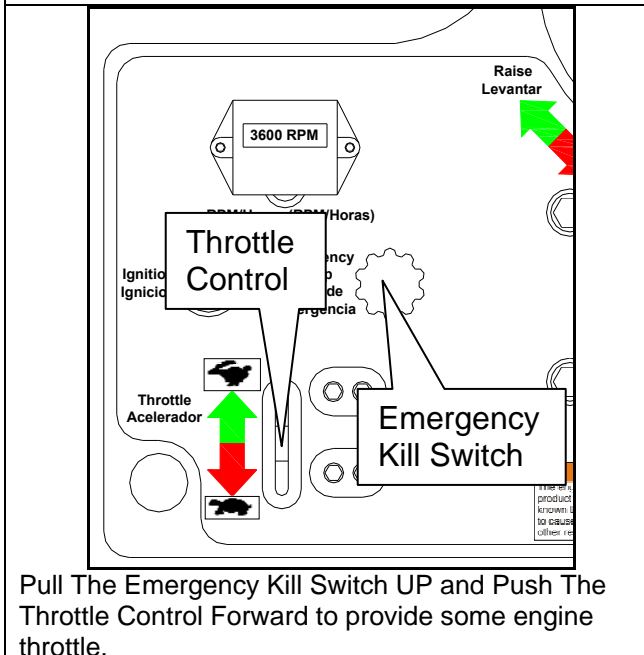
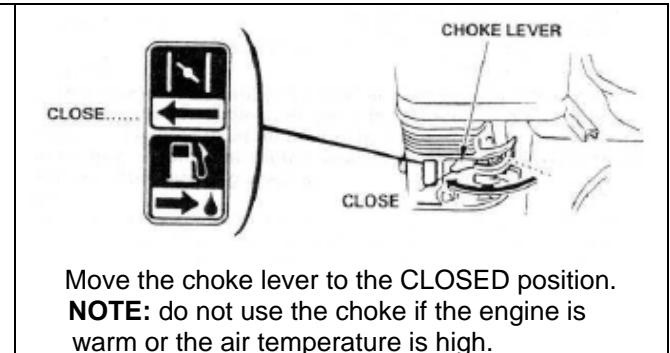
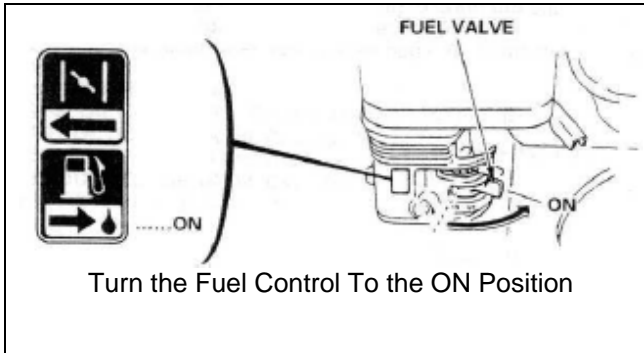

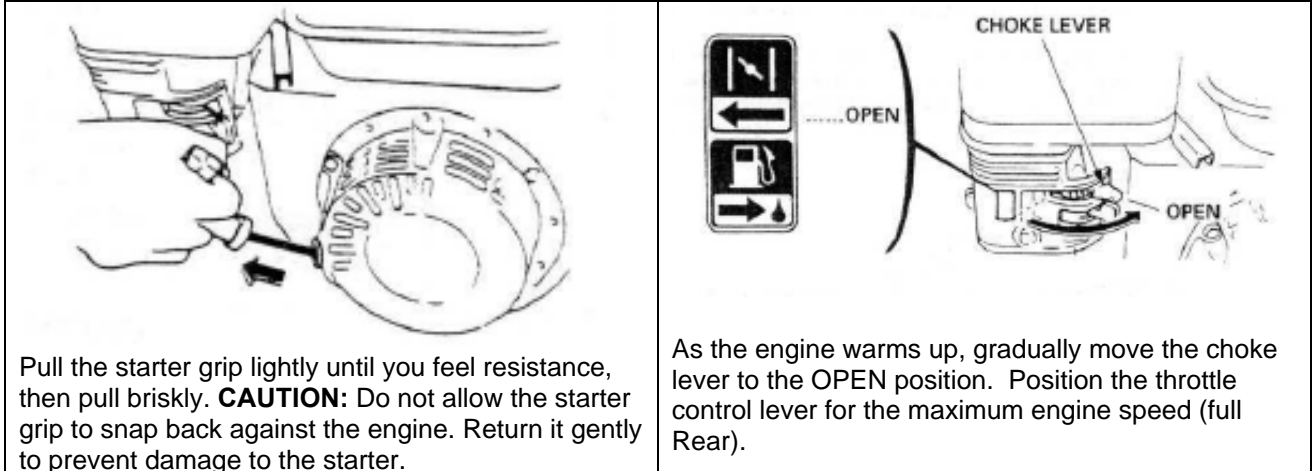

To stop the engine, move the Throttle Control Lever fully to the Rear Position (Slow) right, then turn the engine switch to the OFF position. Turn the fuel valve to the OFF position.



Never transport the machine with the Fuel Valve in the ON position. Never Store the machine with the Fuel Valve in the ON position. Never Transport a machine with the blade installed.

E. Water Supply

Pressurized source: Turn the water control to full "ON" when using wet cutting blades. The required flow rate is 4-6 gallons per minute.

Optional Water Tank on saw: This supply is designed for use with dry blades to keep the dust levels down. The tank will not supply the proper water flow rates when used with wet cut only blades. Do not drink the water from this tank. Fill the tank with water only. Close the water tank valve. Attach the saws water supply hose to the tank outlet. Fill the tank with water. The capacity of the tank is 5 US Gallons. When you are ready to cut, adjust the water supply rate until a fine mist or a slow trickle is made. The use of water greatly decreases the amount of dust produced during the cutting process, aids in the cooling of the blade, and provides additional stability.



Notice
Water Only
Do Not Drink

- Use Only Water In The Water Tank
- Do Not Drink From The Tank

F. Controls

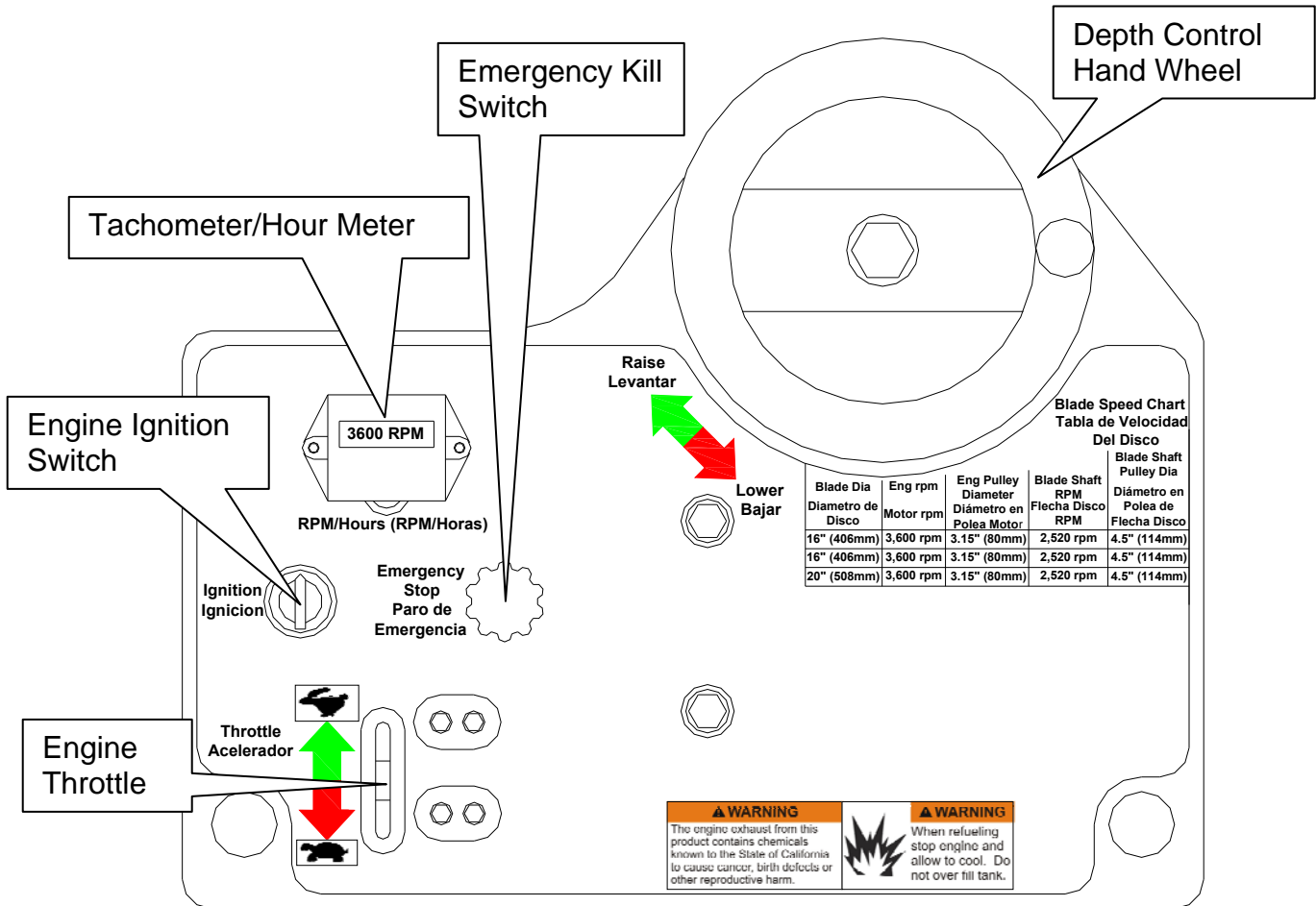

Depth Control Hand Wheel:

Controls the cutting depth of the blade. Rotate Clockwise to raise and counter clockwise to lower the depth of cut.

Engine Throttle:

The Engine Throttle Control allows the operator to adjust the Engine Speed while starting and operating the machine. To increase the Engine Speed push the Engine Throttle Control forward. To decrease the Engine Speed pull the Engine Throttle Control to the rear.

Engine Ignition Switch:

The Engine Ignition Switch allows the operator to start and stop the engine. The C1320P is equipped with a manual start engine. The engine will not start unless the Ignition Key is in the On position, Emergency Kill Switch is pulled out, and the Engine Starter Rope is pulled.

Tachometer/Hour Meter:

The Tachometer/Hour Meter shows the engine RPM only when the Engine is running. The total Engine operating hours (run time) are shown when the Engine is turned off.

Emergency Kill Switch:

The Emergency Kill Switch will stop the engine when depressed. The engine will not restart until the Emergency Kill Switch is pulled out. Use the Engine Ignition Switch for normal shut down of the Engine. Use the Emergency Kill Switch when a problem arises.

G. Operating the Saw

1. For the engine starting instructions see the Engine manual and follow the instructions located in section **II. Operation** sub heading **A. Installing the Blade on page 10.**
2. Check the Engine Oil level.
5. Raise the saw to the full upright position. Do not let the blade come in contact with the ground.
6. Maneuver the saw to the desired starting point.
7. If wet cutting connect the water supply to the saw.
8. Follow the instructions for starting the engine found in the Engine manual.
9. If wet cutting turn on the water supply at the source and then open the water valves on the saw. Make sure that there is a minimum of two gallons per minute of water flow!!
10. Be sure that the engine is running at full throttle!!! Check Engine Speed on the Tachometer to that listed on the Blade Speed Chart located on the Console is correct for the diameter of Blade being used.

Engine and Blade Speed Chart

Blade Diameter	Engine RPM	Engine Pulley Diameter	Blade Shaft RPM	Blade Shaft Pulley Diameter
14" (356mm)	3600 RPM	3.15" (80mm)	2520 RPM	4.5" (114mm)
16" (406mm)	3600 RPM	3.15" (80mm)	2520 RPM	4.5" (114mm)
20" (508mm)	3600 RPM	3.15" (80mm)	2520 RPM	4.5" (114mm)

11. Slowly lower the blade by rotating the hand wheel clockwise until the desired depth of cut is reached. Use a reasonable rate of feed. A reasonable rate of feed will depend on depth of cut, material, and blade. Normal cutting speeds should be between 2 ft/min in very hard material and up to 10 ft/min in softer materials. Do not force the blade in to the cut! If the engine begins to stall or the saw raises out of the cut slow the forward speed down!
12. If the engine begins to stall or the saw raises out of the cut slow the forward speed down!
13. When moving the saw to a new location, be sure the blade is not touching the ground. Always pay close attention to where you are moving and where the blade is at all times.
13. When the end of the cut is reached, slowly raise the blade out of the cut by rotating the Hand Wheel Clockwise until the blade is at least one (1) inch above the ground.
14. To move the machine in reverse raise the blade out of the cut and pull back on the machine. Only move the saw in reverse with the blade in the raise position.
15. When moving the saw to a new location be sure that the blade is not touching the ground and always pay close attention to where you are moving and where the blade is at all times.



Caution: Do Pull The Machine Backwards While The Blade Is In The Cut As The Blade May Be Damaged.

H. Cutting Technique

Lower the blade into the concrete to the required depth by turning the hand wheel clockwise. Ease the handle slowly forward. Retard the forward pressure if the saw begins to stall. Note: For deeper cuts (4 inches or more), several cuts should be made in incremental steps of 1-1/2 to 2 inches until the desired depth of cut is reached. Push the saw steadily forward using the front pointer as a guide. Exert enough forward pressure so that the engine begins to labor, but does not slow down. If the saw begins to stall, retard the forward movement until full rpm is restored to the blade. If the saw stalls, raise the blade out of the cut before restarting. Avoid excessive side pressure or twisting of the blade in the cut.

Additional Guide Lines For Sawing:

- Understand and follow all of the instructions in this owner's manual.
- If wet cutting, turn on the water supply so that there is a minimum of 4-6 gallons per minute of water flow!!
- In critically hard aggregate, more than a single pass may be needed to cut the desired depth.
- If the saw stalls in the cut, immediately stop the forward speed and raise the blade out of the cut. If this is not done the belts can fail or the blade may be damaged.
- Go slowly with a new blade until it opens up, that is, until the diamonds can be seen and felt.

I. Lead-Off Adjustment

If the saw tends to pull to one side (lead off), it may be steered by applying slight pressure to the left or right hand handles.

III. MAINTENANCE

A. Engine Maintenance

Follow the below schedule for engine maintenance. NOTE: Check the Honda Engine manual that came with the engine for any changes to the maintenance schedule. If the charts have any differences, follow the chart in the Honda Engine Manual.

Norton does not warranty the engine. If any warranty or service of the engine is required contact your nearest Honda service center, or from the Internet: <http://www.honda-engines.com/home.htm>

Honda Power Equipment Group
 4900 Marconi Dr.
 Alpharetta, GA 30005-8847
 Tel: (800) 426-7701 | Fax: (678) 339-2670

Honda engine (refer to owner's manual for complete maintenance.)

MAINTENANCE SCHEDULE

REGULAR SERVICE PERIOD Perform at every indicated operating hour interval.		EACH USE	FIRST 20HRS	EVERY 50HRS	EVERY 100HRS	EVERY 300HRS	Refer to page	
ITEM								
Engine oil	Check level	○					3-2	
	Change		○		○			
Reduction gear oil	Check level	○					3-2	
	Change		○			○		
Air cleaner	Check	○					3-3	
	Clean			○ (1)				
Fuel strainer cup	Clean				○		3-7	
Spark plug	Check-Clean				○		3-6	
Valve clearance	Check-Adjust					○	3-5	
Combustion chamber and valves	Clean-Lap					○	9-3,4	
Fuel line	Check (Replace if necessary)		Every 2 years					3-8

NOTE: (1) Service more frequently when used in dusty areas.

Check the engine oil level before each use when the engine is cool and the engine is level. Add oil if the level is low. The oil level should be within the operating range (see the engine owner's manual for details).

Only use a high-detergent, premium quality motor oil certified to meet or exceed U.S. automobile manufacturer's requirements for Service Classification SG, SF/CC, CD. Motor oils will show the classification on the container. A SAE viscosity of 10W-30 is recommend by Honda for general, all temperature use. Please consult the below chart or contact your local Honda service center for the proper viscosity for your temperature range.

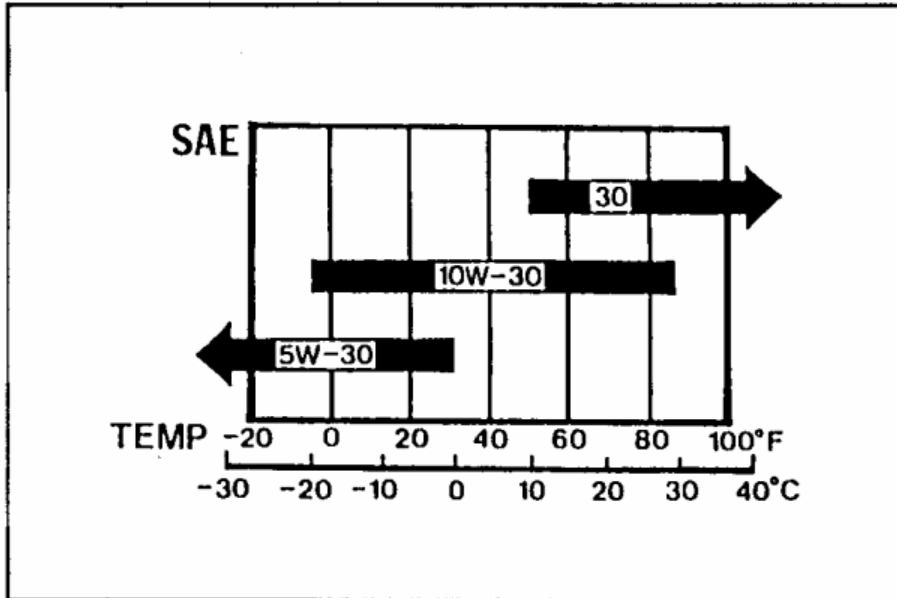

Always refer to the engine manual for more detailed information on checking the oil, changing oil, and oil capacity, air filter changes, and fuel type to use. Use only Honda air filters. Do not clean the air filter with gasoline or other flammable solvents. A fire or explosion could result. To clean, follow the instructions found in the Honda engine manual.

Dry Cutting Engine Maintenance

- When operating the engine in dry cutting or dusty environments the following is required:
- Engine oil changed more often.
- Every 50 hours (or more often if conditions require) clean all of the engine cooling fins.
- Every 25 hours (or more often if conditions require) clean the engine pre-cleaner.
- Every 100 hours (or more often if conditions require) replace the air filter. If the engine is equipped with a reusable air cleaner, clean and re-oil it.
- Check and clean the air filter after each use. Replace as needed.

HONDA TECHNICAL & CONSUMER INFORMATION

Warranty Service Information

Serviceing dealership personal are trained professionals. They should be able to answer any questions you may have. If you encounter a problem that your dealer does not solve to your satisfaction, please discuss it with the dealership's management. The Service Manager or General Manager can help. Almost all problems are solved in this way.

If you are dissatisfied with the decision made by the dealership's management, contact Honda Power Equipment Customer Relations Office. You can write:

Contact information for U.S., U.S. Virgin Islands and Puerto Rico customers only. For all other contact information, go to www.world.honda.com

American Honda Power Equipment Division
4900 Marconi Dr.
Alpharetta, GA 30005-8847

Customer Relations
Tel: 770-497-6400
Fax: 678-339-2519
Mon. - Fri. 8:30 - 7:00 EST

When you write or call, please give us this information:

- Model and serial numbers
- Name of the dealer who sold the engine to you
- Name and address of the dealer who services your engine
- Date of purchase
- Your name, address, and telephone number
- A detailed description of the problem

B. Bearings

Re lubrication type bearings must be relubricated **daily** to assure long life. The grease used should conform to the NLGI grade two consistencies and be free of any chemical impurities such as free acid or free alkali, dust, rust, metal particles or abrasives.

For best results, bearings should be relubricated while in operation. **Note: Due caution for personal safety must be observed when servicing rotating equipment.** The grease should be pumped in slowly until a slight bead forms around the seals. This bead, in addition to acting as an indicator of adequate relubrication, provides additional protection against the entry of foreign matter. If necessary to relubricate while the bearing is idle refer to relubrication table for maximum grease capacity for the various size bearings.

Shaft Size	Maximum Grease Capacity of Bearing Chamber in Ounces
1/2" to 3/4"	1/8
7/8" to 1-3/16"	3/8
1-1/4" to 1-1/2"	5/8



Improper Maintenance Of Bearings Is Not Covered By Any Warranty. Over Lubrication Will Damage A Bearing. Grease Protruding From The Sides Of The Bearing Is A Sign Of Over Lubrication. Not Lubricating Bearings Will Damage The Bearing Unit. Damage Caused By Over or Under Lubricating Bearings Is Not Covered By Any Warranty.

C. V-Belts

Warning: Never make adjustments to belts or pulleys while engine is running!

1. The best tension for a belt drive is the lowest tension at which the belts will not slip under full load.
2. Simply take up the drive until the belts are snug in the grooves. Run the drive for about 15 minutes to "seat" the belts. Then impose the peak load. If the belts slip tighten them until they no longer slip at peak load.

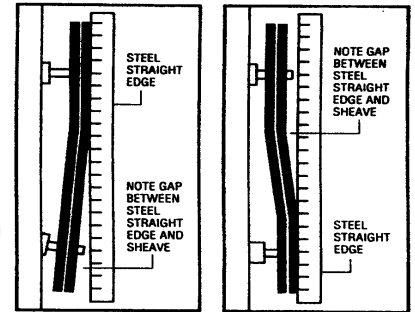

FIGURE 1

FIGURE 2

3. **Remember too much tension shortens belt and bearing life!**
4. Check the belt tension frequently during the first day of operation. Check the belt tension periodically thereafter and make any necessary adjustments.
5. The two most common causes of misalignment are shown in the drawing.
 - a). The engine drive shaft and the blade shaft are not parallel.
See FIGURE ONE
 - b). The pulleys are not located properly on the shafts.
See FIGURE TWO
6. To check alignment, all you need is a steel straight edge.
7. Line up the straight edge along the outside face of both pulleys as shown in the drawing.
8. Misalignment will show up as a gap between the pulley face and the straight edge.
9. Make sure that the width of the outside land is equal on both pulleys.

Main Causes of Belt Failures:

Premature Belt failure can be attributed to the following issues: Tension (too much or too little), Pulley Misalignment, Damaged Pulleys, Improper Handling or Storage, Incorrect Blade Specification for Material Being Cut, and Cutting Too Deep.

Symptom	Possible Cause	Corrective Action
Belt Breakage	Too Much Tension	Re-tension Belts
	Excessive Shock Load	Reduce Load/ Check Blade Specification
	Pulley Out Of Round	Replace Pulley
Burning of Belt	Too Little Belt Tension	Increase Belt Tension
	Excessive Load (Cutting Full Depth)	For Best Performance Only Cut only 1-1/2" to 2" Per Pass
	Containments On Belts	Replace Belts and Find Source Of Containments
	Incorrect Blade Specification	Replace Blade With One Designed For Material Being Cut
Belt Tearing/Ripping	Pulley Misalignment	Align Pulleys
Belt Rolling Off Pulley	Pulley Misalignment	Align Pulleys
Belt Cracking	Extremely Low Temperature at Startup	Warm Machine Before Use
	Exposure To Chemicals or Lubricates	Locate Source of Containments and Replace Belts.



Belts are a normal wear item and are not covered under warranty.

D. Depth Control

The depth control (raising screw) consists of a threaded rod which feeds into a brass nut. In order to keep the two parts working smoothly it is necessary to keep the rod free from dirt and sludge as much as possible. Cleaning the threaded rod with a rag after each use will prevent sludge from collecting in the tube assembly and protect the threads. It is a good practice to keep the raising screw threads lubricated, as the slurry generated during cutting will cause premature thread wear.

The bearing used to support the raising screw should be checked after each use to make sure it is turning freely and lubricated. If the bearing requires re lubrication lithium base grease is recommended.



Over tightening the Hand Wheel during the raising or lowering the Saw will damage the raise screw or Bearing. The Operator should stop rotating the Hand Wheel when resistance is felt or when the machine is raised to its highest position or completely lowered.

F. Inspections and Cleaning

For long life and better machine performance follow the inspection and cleaning schedule below.

		Regular Service Period Performed At Every Indicated Period →						
		After First Hour of Work	Beginning Of Day	During Blade Change	End Of Day	Once A Week	After Failure	After Damage
Whole Machine	Inspect For Damaged or Missing Components	X	X			X	X	X
	Clean		X			X		
Blade Collars	Clean			X				
Belt Tension	Check	X				X	X	X
Water Hose, Water Fittings, and Nozzles	Clean		X			X		
	Inspect		X			X		X
Depth Screw	Grease					X		
Engine	Clean					X		
Reachable Hardware	Tighten					X		
Bearings (Blade Shaft and Depth Control)	Grease*					X		
Wheels	Inspect	X	X			X		
Handle Bar Vibration Reduction System	Inspect	X	X			X	X	X

* = See Bearing Maintenance of This Manual Before Greasing



Replace any damaged or missing components before using machine.

E. ELECTRICAL DIAGRAM C1320P: 13HP Manual Start Models Only

Color Chart

Honda Supplied Wiring

Honda Code	Honda Color
(BL)	Black
(G)	Green
(Y)	Yellow

Wiring Harness

Wiring Code*	Wiring Color
BL	Black

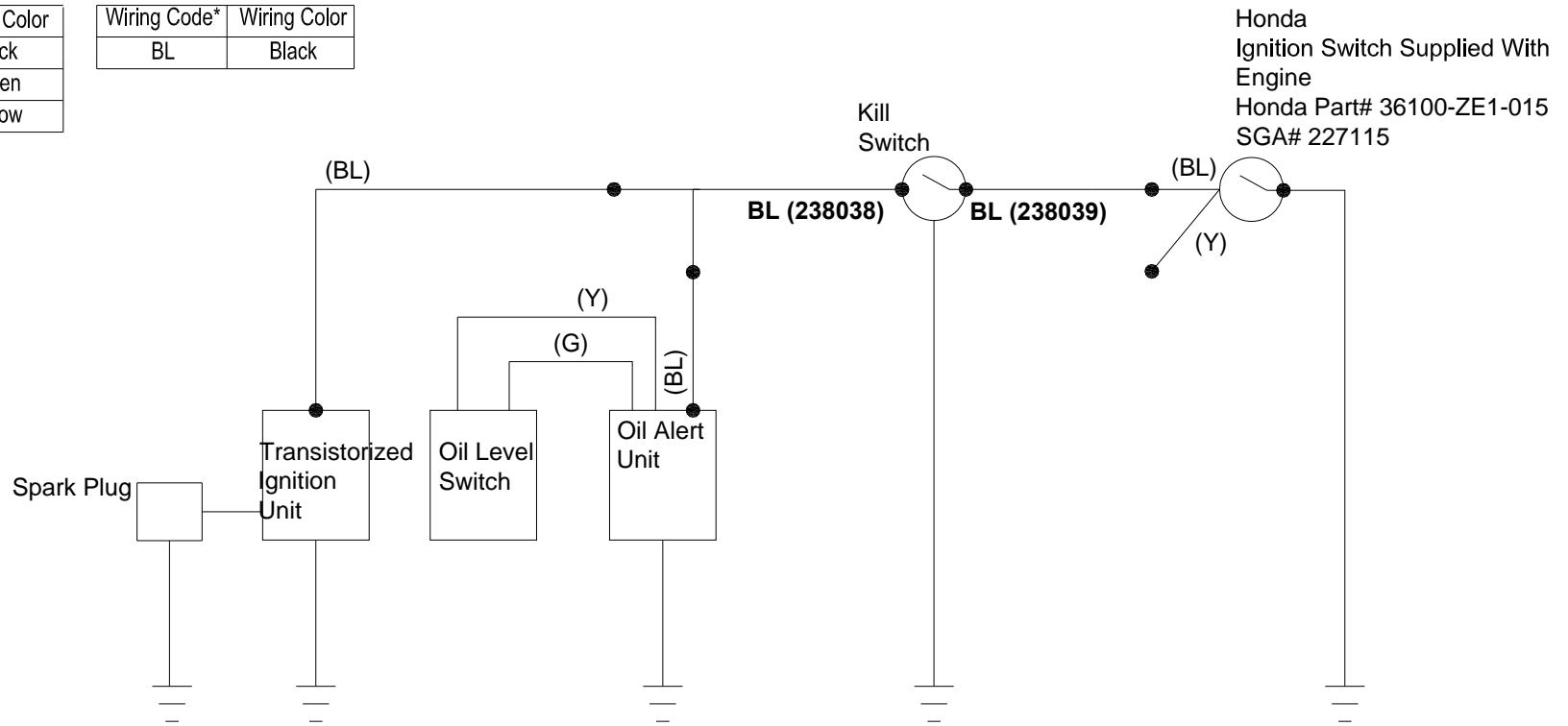

IV. PARTS LIST SECTION

A. Ordering Information

1. List model number and serial number of machine.
2. List part number and serial number of part not the item number.
3. Wherever alternate parts are shown due to product improvement, inspect the part you have and provide additional description as necessary.
4. Specify mode of shipping desired, such as, parcel post, truck, U.P.S., best way, etc.

For the nearest Norton Clipper distributor call **254-918-2310**

Common Replacement Parts

Description	Part No	UPC No
BELT 3VX300 (4)	238261	70184646724
BLADE SHAFT NUT RIGHT SIDE (LEFT HAND THREADS)	227156	70184673903
BLADE SHAFT NUT LEFT SIDE (RIGHT HAND THREADS)	227191	70184674346
TIGHT COLLAR RIGHT SIDE (LEFT HAND THREADS)	227159	70184673904
TIGHT COLLAR LEFT SIDE (RIGHT HAND THREADS)	227190	70184674352
LOOSE COLLAR OUTER FLANGE W/ Drive Pin	227247	70184674082
PIN DRIVE (GROOVED) 3/8X1	227154	70184674556
BEARING PIL BLK 1-1/4	106218	70184650306
WHEEL 6 X 2 X 3/4 W/ROLLER BEARING	238005	70184626921
WHEEL 5 X 2 X 3/4 W/ROLLER BEARING	238004	70184626920
WRENCH OPEN END 1-1/4	238212	70184628071
WRENCH OPEN END 1-1/2	238213	70184628074

NOTE: All Parts Are Sold As Individual (each) Unless Noted Otherwise

Blades Use Only Norton Diamond Blades. Contact your local Norton Clipper Distributor or our Customer Service at 254-918-2310 for the best blade for the application.

All parts are designated as either Service Parts (S) or Wear Parts (W) in the Type column in the parts listing. Wear parts are worn out through normal use of the machine. The wear period depends on the intensity of use of the machine, handling, and maintenance of the machine. Wear parts must be serviced and eventually changed following the indications of the manufacturer. Any wear due to normal use of the machine will not be considered as a case of warranty for items designated as Wear Parts (W). For best performance and life Genuine Norton Clipper replacement parts should always be used. Changes to part specifications, are subject to change with out notice..

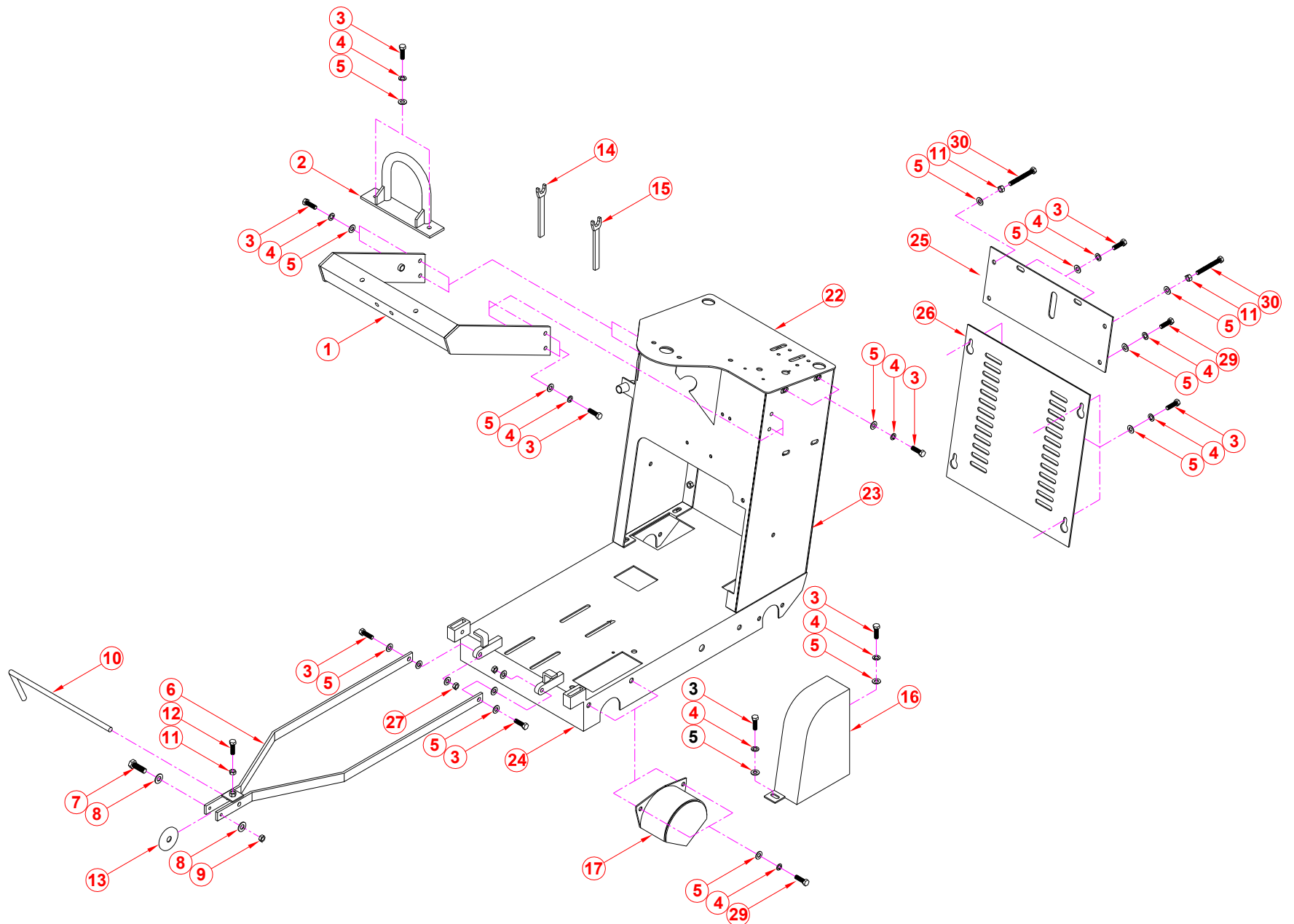

C1320P Frame Group

C1320P Frame Group

Item	Part No	UPC No	Description	QTY	Type	NOTES
1	238171	70184628065	LIFT FRAME	1	S	
2	238175	70184628066	LIFT FRAME HOOK	1	S	
3	8041051	70184649901	SCR 3/8-16 X 1 1/4 HEX HD CAP	23	S	
4	8177012	70184650149	WASHER 3/8 SPRING LOCK	23	S	
5	8172009	70184650123	WASHER 3/8 SAE	23	S	
6	238177	70184628067	FRONT POINTER FRAME	1	S	
7	8041035	70184649893	SCR 5/16-18 X 2-3/4 HEX HEAD	1	S	
8	8172008	70184650391	WASHER 5/16 SAE	2	S	
9	8160002	70184650372	NUT 5/16-18 HEX LOCK	1	S	
10	238168	70184628068	POINTER ROD	1	S	
11	8142003	70184650349	NUT 3/8-16 HEX	1	S	
12	8041052	70184649902	SCR 3/8-16 X 1 1/2 HEX HD CAP	1	S	
-NA-	238211	70184628070	ROPE 1/4"ODX16'-3/8"	1	W	
13	238215	70184630652	WHEEL 3" X 1" X 5/16"	1	W	
14	238212	70184628071	WRENCH OPEN END 1-1/4	1	S	
15	238213	70184628074	WRENCH OPEN END 1-1/2	1	S	
16	238260		GUARD BELT C1320P	1	S	
17	238136	70184628075	SHAFT GUARD	1	S	
22	238121		CONSOLE TOP C1320P/C1320SS	1	S	
23	238114	70184628078	CONSOLE WELDMENT	1	S	
24	238259		FRAME C1320P	1	S	
25	238140	70184628080	CONSOLE TOP REAR COVER	1	S	
26	238141	70184628081	CONSOLE REAR COVER	1	S	
27	8162003	70184650380	NUT 3/8-16 HEX LOCK	2	S	

Type: S = Service Part, W = Wear Part, All Parts Are Sold As Individual (each) Unless Noted Otherwise

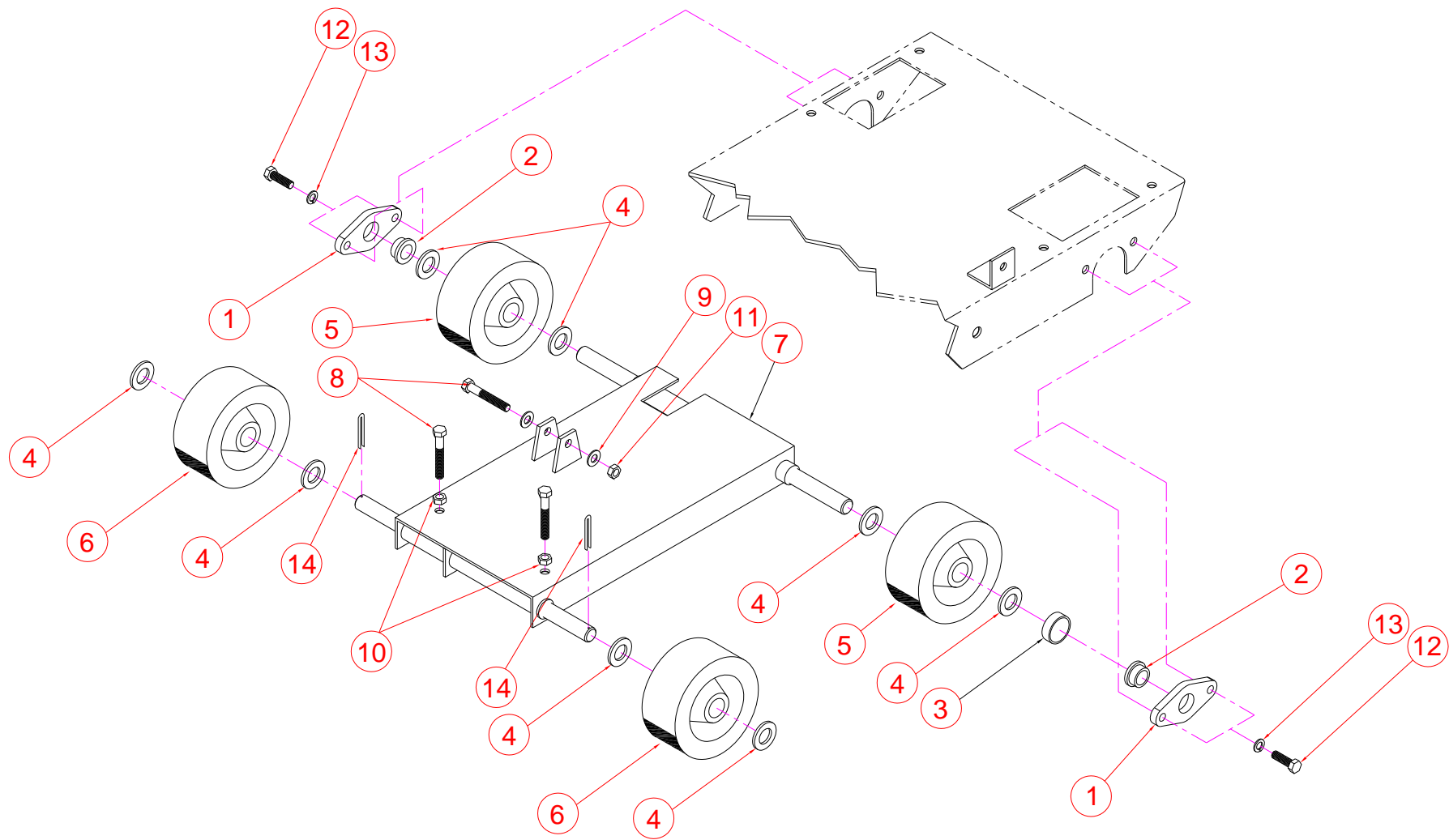

C1320P Raise Axle Group

C1320P Raise Axle Group

Item	Part No	UPC No	Description	QTY	Type	NOTES
1	238134	70184628082	RAISE AXLE MOUNT	1	S	Sold as Each.
2	238129	70184628085	REAR AXLE BUSHING	1	W	
3	238124	70184628272	REAR WHEEL SPACER	2	S	
4	8172015	70184650129	WASHER 3/4 SAE	8	S	
5	238005	70184626921	WHEEL 6 X 2 X 3/4 W/ROLLER BEARING	2	W	Sold as Each. Includes Roller Bearing
6	238004	70184626920	WHEEL 5 X 2 X 3/4 W/ROLLER BEARING	2	W	Sold as Each. Includes Roller Bearing
7	238126	70184628083	RAISE AXLE WELDMENT	1	S	
8	8041056	70184649906	SCR 3/8-16 X 2 1/2 HEX HD CAP	3	S	
9	8172009	70184650123	WASHER 3/8 SAE	1	S	
10	8142003	70184650349	NUT 3/8-16 HEX	12	S	
11	8162003	70184650380	NUT 3/8-16 HEX LOCK	1	S	
12	8041051	70184649901	SCR 3/8-16 X 1 1/4 HEX HD CAP	4	S	
13	8177012	70184650149	WASHER 3/8 SPRING LOCK	4	S	

Type: S = Service Part, W = Wear Part, All Parts Are Sold As Individual (each) Unless Noted Otherwise

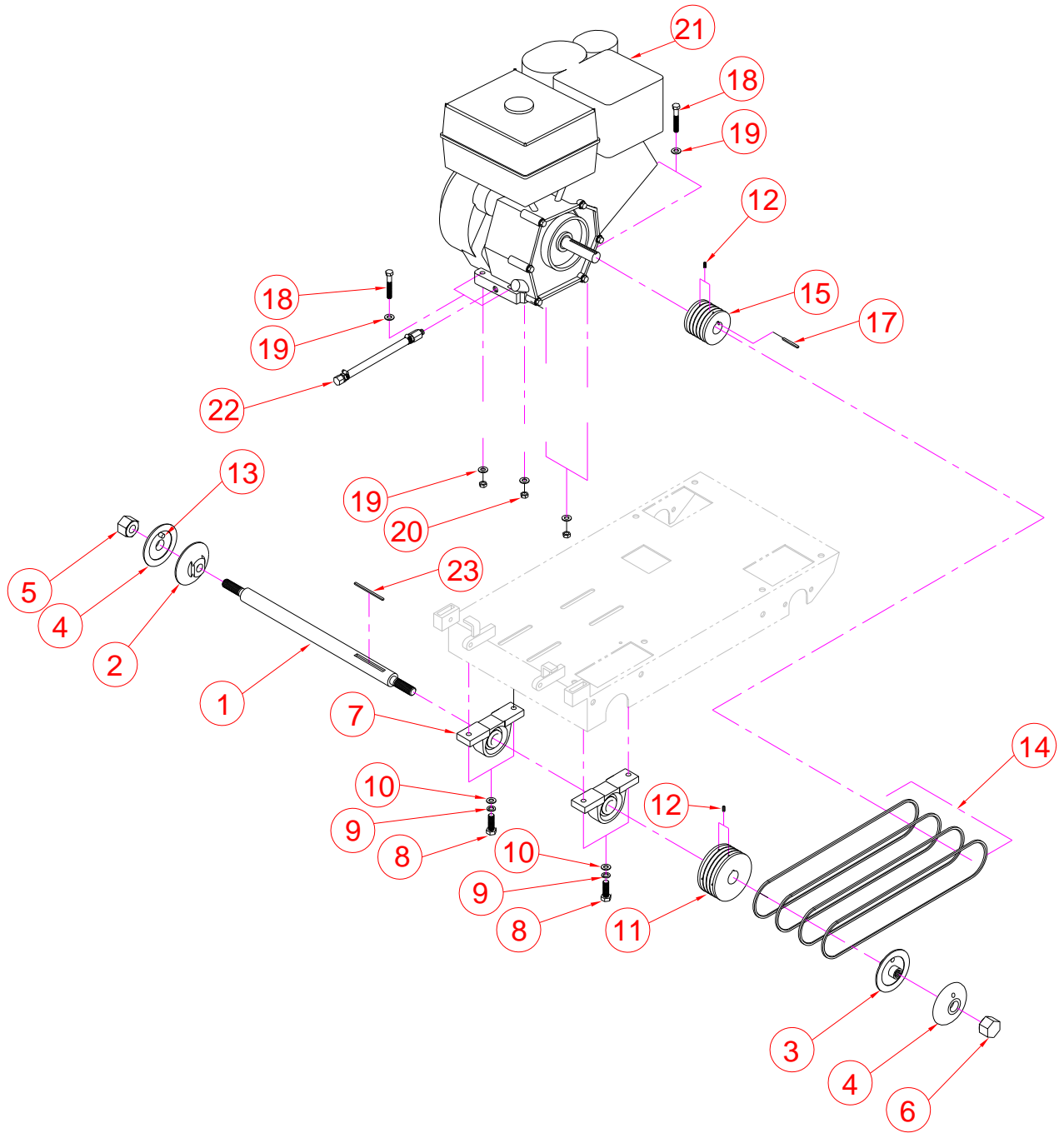

C1320P Blade Shaft & Engine Group

C1320P Blade Shaft & Engine Group

Item	Part No	UPC No	Description	QTY	Type	NOTES
1	238179	70184628084	BLADE SHAFT	1	S	
2	227159	70184673904	TIGHT COLLAR RIGHT SIDE	1	S	LEFT HAND THREAD
3	227190	70184674352	TIGHT COLLAR LEFT SIDE	1	S	RIGHT HAND THREAD
4	227247	70184674082	LOOSE COLLAR OUTER FLANGE	2	S	INCLUDES DRIVE PIN
5	227156	70184673903	NUT BLADE SHAFT 3/4-16 LH	1	S	OPERATOR'S RIGHT SIDE
6	227191	70184674346	NUT BLADE SHAFT 3/4-16 RH	1	S	OPERATOR'S LEFT SIDE
7	106218	70184650306	BEARING PIL BLK 1-1/4 2-B	2	W	
8	8041095	70184649919	SCR 1/2-13 X 1 1/4 HEX HD CAP	4	S	
9	8176014	70184650139	WASHER 1/2 SPRING LOCK	4	S	
10	8172011	70184650124	WASHER 1/2 SAE	4	S	
11	238015	70184628173	PULLEY 4.5OD X 1.25B 4G 3VX	1	S	
12	407036	70184682130	1/4-20 X 3/8 SOCKET SET SCREW	4	S	
13	227154	70184674556	PIN DRIVE (GROOVED) 3/8X1	2	W	
14	238261	70184646724	BELT 3VX300 (4)	1	W	
15	238013	70184628174	Pulley 3.15 OD x 1.00 ID 5G 3VX	1	S	
17	9201125	70184649710	KEY 1/4 X 2 1/2	1	S	
18	8041054	70184649904	SCR 3/8-16 X 2 HEX HD CAP	4	S	
19	8172009	70184650123	WASHER 3/8 SAE	8	S	
20	8162003	70184650380	NUT 3/8-16 HEX LOCK	4	S	
21	123327	70184671620	ENGINE 13 HP MANUAL START	1	S	GX390K1QXC9
22	238057	70184628179	OIL DRAIN HOSE ASSY 13HP	1	S	
23	9201123	70184649709	KEY 1/4 X 2-1/4	1	S	

Type: S = Service Part, W = Wear Part, All Parts Are Sold As Individual (each) Unless Noted Otherwise

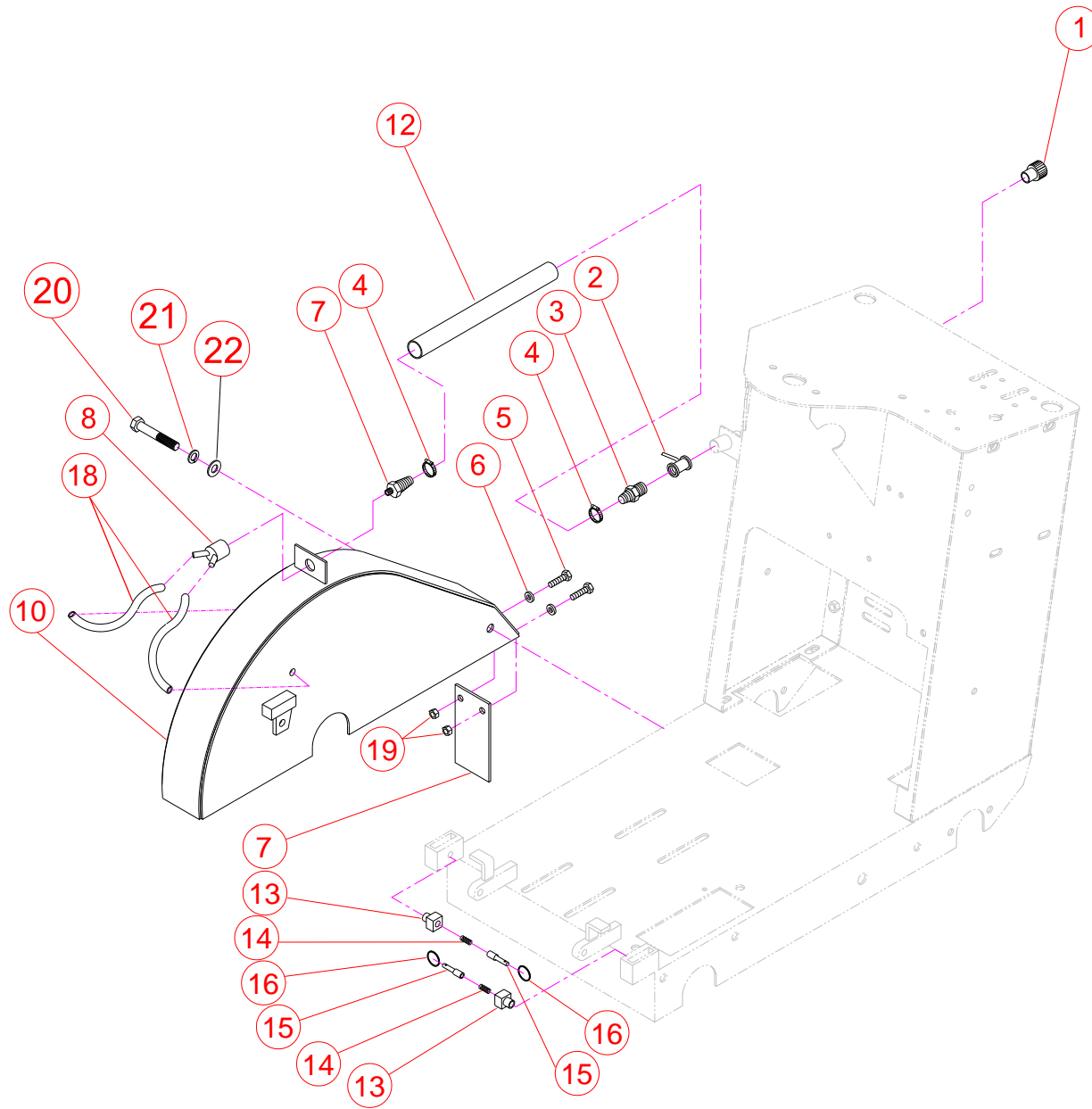

C1320P Blade Guard and Water System Group

C1320P Blade Guard and Water System Group

Item	Part No	UPC No	Description	QTY	Type	NOTES
1	N1D0082	70184659115	HOSE SWIVEL	1	S	
2	N1C0021	70184659097	WATER VALVE 1/2"	1	S	
3	9602012	70184626501	HOSE BARB 1/2" x 1/2"MPT	1	S	
4	N1C0113	70184659232	HOSE CLAMP	2	S	
5	8041006	70184649879	SCR 1/4-20 X 1 HEX HD CAP	2	S	
6	8172007	70184650120	WASHER 1/4 SAE	2	S	
7	9600014	70184650465	FIT BARB HOSE 1/4MPTX1/2	2	S	
8	72286	00310004233	"Y" FITTING x 1/4FPT	1	W	
10	238142	70184628496	BLADE GUARD 20"	1	S	BLADE GUARD ONLY
12	0042521	70184683507	TUBE 1/2ID X 3/4OD 48"LNG	1	W	USE 36"
13	238225	70184628498	GUARD LOCK	2	S	
14	238224	70184628499	SPRING GUARD LOCK	2	S	
15	238222	70184628500	PIN GUARD LOCK	2	S	
16	238223	70184628501	RING GUARD LOCK	2	S	
17	8160001	70184650371	NUT 1/4-20 HEX LOCK	2	S	
18	082998	70184681299	NOZZEL WATER (2)	1	W	Set of Two (2) Nozzles
19	238137	70184628185	SPLASH GUARD ONLY	1	S	AKA: FLAP OR MUD FLAP
20	8041107	70184649929	SCR 1/2-13 UNC x 4-1/2 HEX HEAD CAP	1	S	
21	8176014	70184650139	WASHER 1/2 SPRING LOCK	2	S	
22	8172011	70184650124	WASHER 1/2 SAE	2	S	

Type: S = Service Part, W = Wear Part, All Parts Are Sold As Individual (each) Unless Noted Otherwise

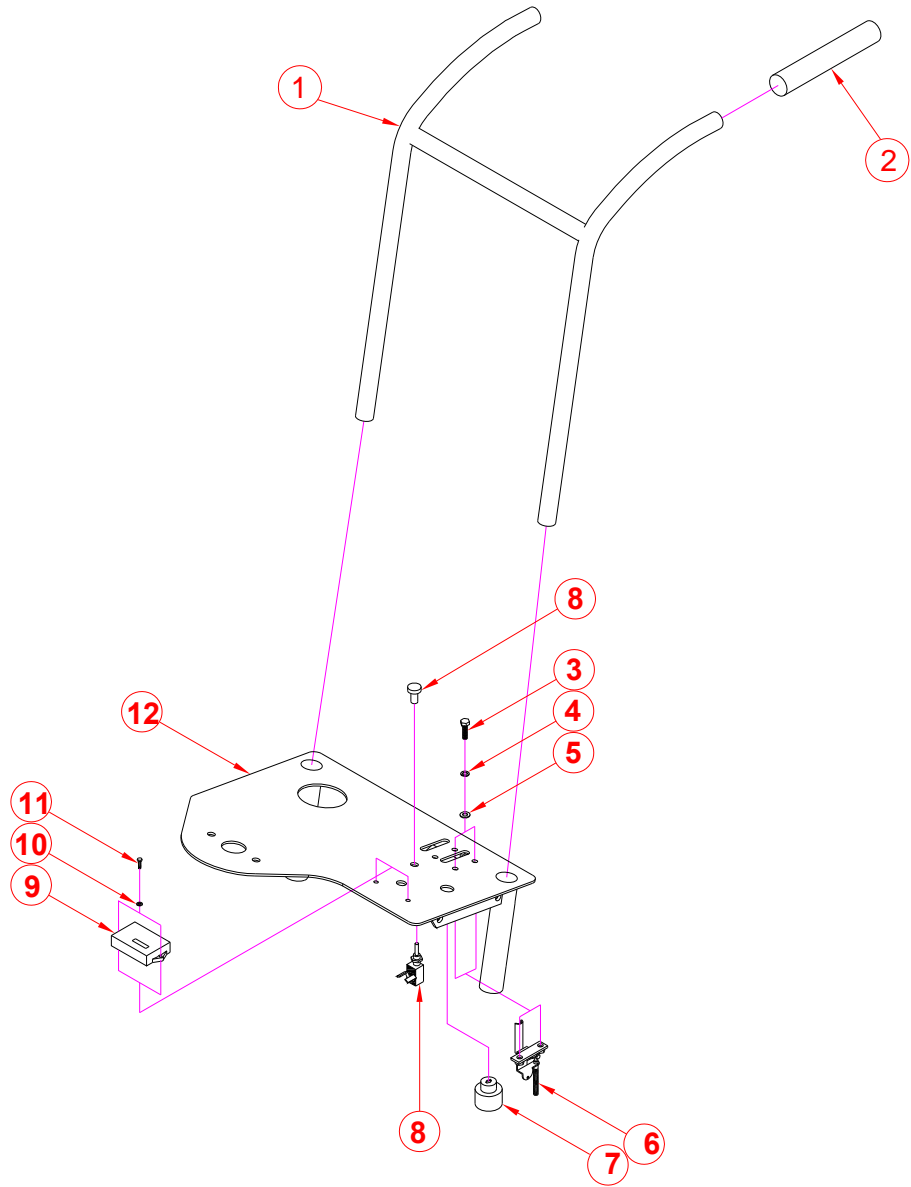

C1320P Controls and Console Group

C1320P Controls and Console Group

Item	Part No	UPC No	Description	QTY	Type	NOTES
1	238120	70184627887	HANDLE BAR	1	S	
2	N1C0004	70184659110	HANDLE BAR GRIP	2	W	
3	8041006	70184649879	SCR 1/4-20 X 1 HEX HD CAP	2	S	
4	8177010	70184650144	WASHER 1/4 SPRING LOCK	2	S	
5	8172007	70184650120	WASHER 1/4 SAE	2	S	
6	238228	70184628446	THROTTLE CABLE	1	W	Includes Cable And Control. 29" Long
7	227115	70184674394	SWITCH IGNITION 13HP HONDA	1	S	Switch Only
8	238229	70184628277	EMERGENCY KILL SWITCH	1	S	
9	232080	70184682239	TACHOMETER	1	S	
10	8172005	70184650116	WASHER #10 SAE	2	S	
11	8042007	70184627236	SCR No. 10-24 X 1 SOCKET HD	2	S	
12	238121		CONSOLE TOP C1320P/C1320SS	1	S	

Type: S = Service Part, W = Wear Part, All Parts Are Sold As Individual (each) Unless Noted Otherwise

C1320P Depth Adjustment Group

Item	Part No	UPC No	Description	QTY	Type	NOTES
1	238164	70184628181	DEPTH SCREW TUBE	1	S	
2	238234	70184628182	GREASE ZERK 1/8	1	S	
3	407035	70184682129	SCR 1/4-20 X 1/4 SET CUP	1	S	
4	238163	70184628265	NUT 3/4-10 HEX HEAD	1	S	
5	238165	70184628183	RAISE SCREW	1	S	
6	238166	70184628274	DEPTH STOP BUSHING	1	S	
7	210071	70184650406	BEARING FLANGE 3/4 B	1	W	
8	8143005	70184650358	NUT 1/2-13 HEX HEAD	1	S	
9	238233	70184628275	DEPTH STOP ROD 1/2-13 X 7"	1	W	
10	8172011	70184650124	WASHER 1/2 SAE	1	S	
11	N1C0078	70184659262	DEPTH STOP HANDLE	1	S	
12	8160005	70184650375	NUT 1/2-13 HEX LOCK	1	S	
13	238167	70184628276	HAND-WHEEL SPACER	1	S	
14	238169	70184628444	HAND-WHEEL	1	S	
15	8172013	70184650127	WASHER 5/8 SAE	1	S	
16	8177016	70184650156	WASHER 5/8 SPRING LOCK	1	S	
17	238235	70184628184	ACORN NUT 5/8-11	1	S	
18	8041052	70184649902	SCR 3/8-16 X 1 1/2 HEX HD CAP	2	S	
19	8172009	70184650123	WASHER 3/8 SAE ZN PLT	4	S	
20	9201080	70184662750	KEY 3/16 X 1 1/4	1	S	
21	8177012	70184650149	WASHER 3/8 SPRING LOCK	4	S	
22	8041056	70184649906	SCR 3/8-16 X 2 1/2 HEX HD CAP	1	S	

Type: S = Service Part, W = Wear Part, All Parts Are Sold As Individual (each) Unless Noted Otherwise

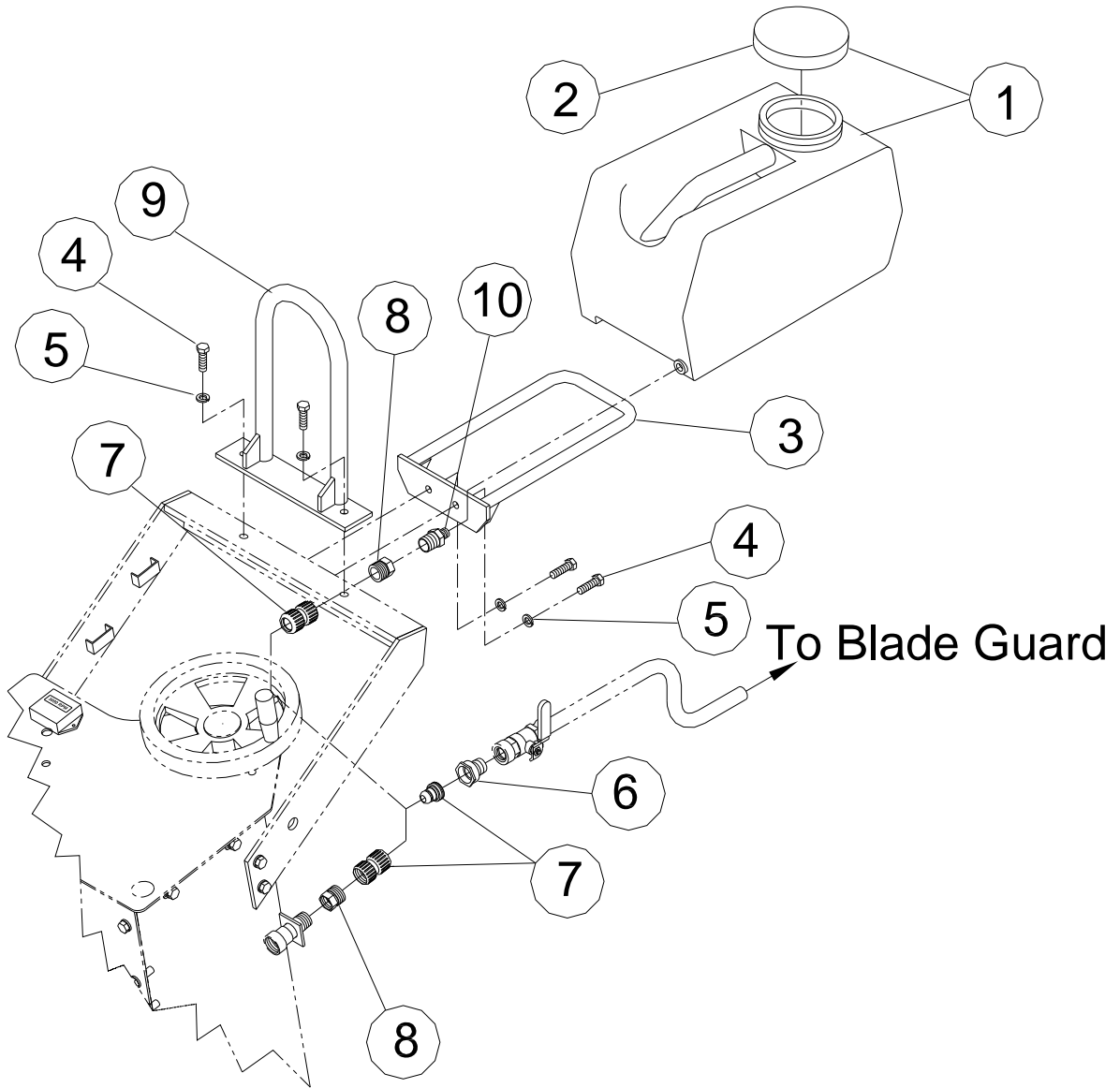

C1320P Optional Water Tank Group

C1320P Optional Water Tank Group

Item	Part No	UPC No	Description	QTY	Type	NOTES
-NA-	238001	70184628014	WATER TANK KIT	1	S	INCLUDES: Items 1, and 3 to 10
1	83357	00310007011	WATER TANK W/CAP	1	W	
2	82794	00310006560	CAP FOR WATER TANK	1	S	
3	238174	70184628015	BRACKET FOR WATER TANK	1	S	
4	8041051	70184649901	SCR 3/8-16 UNC x 1-1/4 HEX HEAD CAP	4	S	
5	8177012	70184650149	WASHER 3/8 SPRING LOCK	4	S	
6	238065	70184628018	REDUCER FIT 3/4FGH x 1/2MPT	1	S	
7	238066	70184628019	COUPLER QUICK DETACH (INCLUDES MALE & FEMALE QD COUPLERS)	2	S	
8	238067	70184628020	REDUCER FIT 3/4MGH x 1/2FPT	2	S	
9	238173	70184628016	LIFTING HOOK FOR WATER TANK C13xx/C20xx	1	S	
10	83218	70184682454	REDUCING BUSHING 1/2MPT X 1/4MPT	1	S	

Type: S = Service Part, W = Wear Part, All Parts Are Sold As Individual (each) Unless Noted Otherwise

NOTE: 238001 Water Tank Kit Includes: 83357 (Water Tank with Cap), 238174 (Bracket for Water Tank), 238173 (Lifting Hook for Water Tank), 238065 (Reducer Fitting 3/7 FGH x 1/2MPT), 238066 (Coupler Quick Detach Male & Female Kit), 238067 (Reducer Fitting 3/4 MGH x 1/2 FPT), 83218 (Reducing Bushing 1/2 MPT x 1/4 MPT), 8041051 (x4) (Screw 3/8-16 x 1-1/4 Hex Head Cap), 8177012 (x4) (Washer 3/8 Spring Lock).

Saint-Gobain Abrasives

2770 West Washington
Stephenville, TX 76401
Phone: 254-918-2310
Fax: 254-918-2312

The Norton logo consists of the word "NORTON" in a bold, italicized, white sans-serif font, set against a blue parallelogram background that is wider at the top and tapers towards the bottom.

NORTON

SAINT-GOBAIN

WARNING

Some dust created by power sanding, sawing, grinding, drilling, and other construction activities contains chemicals known to cause cancer, birth defects or other reproductive harm. Some examples of these chemicals are:

- **Lead from lead-based paints,**
- **Crystalline silica from bricks and cement and other masonry products, and**
- **Arsenic and chromium from chemically-treated lumber.**

Your risk from these exposures varies, depending on how often you do this type of work. To reduce your exposure to these chemicals: work in a well ventilated area, and work with approved safety equipment, such as those dust masks that are specially designed to filter out microscopic particles.