

**DIAMOND  
PRODUCTS**

**CONCRETE SAW  
PARTS LIST**

**MODEL  
CC1300XL  
(Gas)**

May 2011

# GENERAL SAFETY WARNINGS AND PRECAUTIONS

## PERSONAL SAFETY

- Read and understand all operating instructions before attempting to operate the saw.
- Always wear safety approved hearing, eye, head and respiratory protection.
- Always wear sturdy boots with non-slip soles to ensure proper footing. Use of steel toed safety boots is recommended.
- Due to the nature of concrete cutting, sparks may be generated therefore never wear clothing that is made of flammable material.
- Know how to stop the saw quickly in case of emergency.
- Keep all parts of your body away from the blade and all other moving parts.
- Use caution and follow all instructions when loading and unloading the saw.

## BLADE SAFETY

- Examine cutting blades before each use. Blade should have no cracks, nick, or flaws. The center hole must be undamaged. Use only blades recommended for your particular model saw.
- The saw should only be used for cutting material that is specified on each cutting blade. Read the instructions provided with each blade to determine which material the blade is designed to cut.
- Use only reinforced abrasive blades or steel centered diamond blades manufactured for use on concrete saws.
- Inspect blade flanges for damage, excessive wear and cleanliness before mounting the blade. The blade must fit snugly on the clean, undamaged blade shaft.
- Observe the specified maximum speed of the blade. Never use a blade that has a lower maximum operating speed than the blade shaft speed.
- The ignition governor is designed to limit the maximum no-load engine speed. Speeds in excess of that may cause the blade to exceed the maximum blade speed. Do not operate the unit at speeds greater than the maximum blade speed.
- Always keep guards in place and never allow the blade exposure on the guard to exceed 180 degrees. Repair or replace damaged guards immediately.
- Never expose anyone to the direct line of the blade.
- Make sure that the blade does not come in contact with the ground or any other surface when transporting the saw.

## GENERAL SAW SAFETY

- The saw must never be left unattended when the engine is running.
- Keep both hands on the handles when operating the saw.
- Never operate the saw if there is a fuel leak.
- Use extreme caution and slow speed when using the self propelled drive to move the saw up or down ramps or when loading and unloading from trucks or trailers. When going down ramps, DRIVE the saw forward slowly. When going up ramps, BACK the saw in reverse slowly.

## CUTTING / WORK AREA SAFETY

- Never operate the saw in any application or job in which you are not trained or supervised.
- Always ensure that the work area does not contain any buried or embedded electrical lines, gas lines or water lines. Ensure that all electricity in the ground, floor, walls or ceilings is shut off prior to cutting. Ensure that all gas and water lines that may be buried or embedded in the ground, floor, walls or ceilings are shut off prior to cutting.
- Operate the saw only in well ventilated areas. Engine exhaust contains carbon monoxide which can cause loss of consciousness and death.
- Keep bystanders and animals out of the work area.
- Observe all safety regulations for the safe handling of fuel. Store fuel in appropriate safety containers. Shut off the engine and allow it to cool prior to fueling. Wipe off any spilled fuel. Always move away from the fueling area prior to starting saw.
- Do not operate the saw in areas which contain combustible material or fumes. Sparks may occur from cutting that could cause a fire or explosion.

***Concrete cutting as all construction work is inherently dangerous!***

***Failure to comply with the preceding warnings could result in serious bodily injury!***

## Table of Contents

<u>Description</u>	<u>Page No.</u>
Common Parts.....	4 - 5
Front Axle Assembly.....	6
Screw Feed Assembly.....	7
Engine Group – 8 Horsepower Honda.....	8 - 9
Engine Group – 11 Horsepower Honda.....	10 - 11
Engine Group – 11 Horsepower Honda for 20" Guard.....	12 - 13
Engine Group – 9 Horsepower Robin.....	14 - 15
Blade Shaft Assembly.....	16
14" Blade Guard Assembly.....	17
18" Blade Guard Assembly.....	18
20" Blade Guard Assembly.....	19
Pointer Assembly.....	20
Water Tank Option Group.....	21
Notes.....	22
Warranty.....	24

### Quick Reference Service: Filters & Belts

<u>DP Part No.</u>	<u>Description</u>	<u>Manufacturer's Part No.</u>
2702018	Air Filter for 8 & 11 HP Honda	(Honda #17210-ZE3-505)
2704122	Air Filter for 9 HP Robin	(Robin #279-32607-07)
2704148	Fuel Filter for 9 HP Robin	(Robin #064-13600-10)
2500034	Belt for 8 HP Honda & 9 HP Robin	(Gates #3VX315)
	& 11 HP Honda with 20" Blade Guard	
2500380	Belt for 11 HP Honda	(Gates #3VX300)

# CC1300XL Common Parts

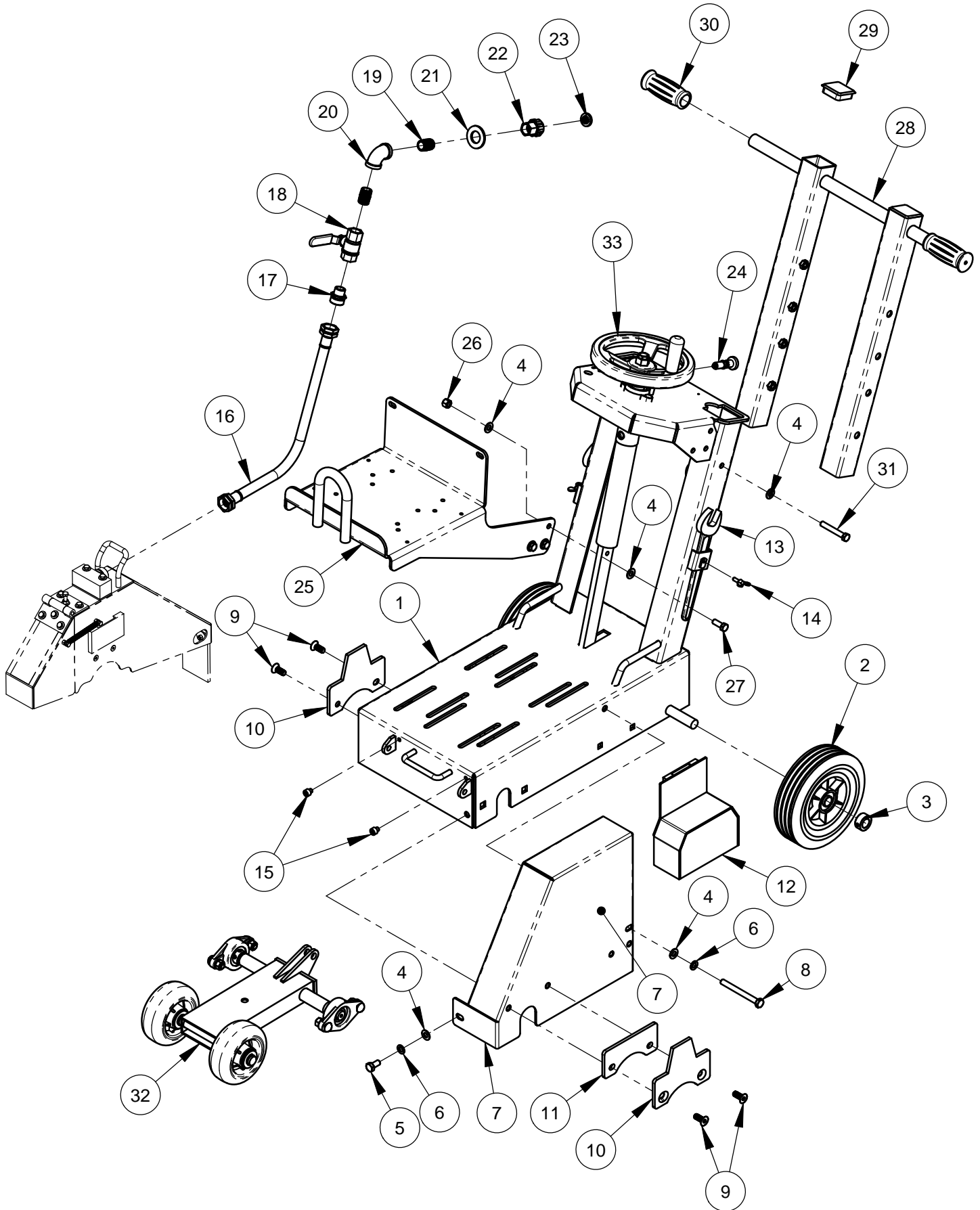

**CC1300XL Common Parts - 6090147 (Regular Cut)**  
**- 6048877 (Upcut)**

ITEM	PART NO.	QTY.	DESCRIPTION
1	6048181	1	Frame Weldment (Regular Cut)
	6048269	1	Frame Weldment (Upcut)
2	2501439	2	Wheel, 8 x 2 x 3/4"
3	2400615	2	Set Collar, 3/4"
4	2900014	16	Flat Washer, 3/8" SAE
5	2900314	1	Cap Screw, Hex Hd., M10-1.5 x 20mm
6	2900321	2	Lock Washer, M10 Split
7	6048001	1	Belt Guard (Regular Cut)
	6048149	1	Belt Guard (Upcut)
8	2900320	1	Cap Screw, Hex Hd., M10-1.5 x 100mm
9	2900744	4	Capscrew, Flat Hd., M10 x 25mm
10	6048908	2	Tapered Guard Mount
11	6048915	1	Tapered Guard Mount Spacer
12	6048906	1	Shaft Guard
13	2500256	2	Wrench Head
14	2900307	2	Wing Screw, M6 x 16mm
15	2900980	2	Capscrew, Soc. Hd., M8 X 10mm
16	6011055	1	Water Hose Assembly, 30" Long
17	3200155	1	Fitting, 1/2" M. Pipe to 3/4" M. Garden
18	3200027	1	Water Valve
19	3200008	2	Close Nipple, 1/2" NPT
20	3200209	1	Pipe Elbow, 1/2" Female
21	2900425	1	Flat Washer, 7/8" SAE
22	3200022	1	Fitting, 1/2" F. Pipe to 3/4" F. Garden
23	3200025	1	Hose Filter Washer
24	2400138	1	Indexing Plunger 1/2-13
25	6030318	1	Lift Bar Assembly
26	2900018	6	Lock Nut, 3/8-16 Nylon
27	2900005	6	Cap Screw, Hex Hd., 3/8-16 x 1"
28	6040213	1	Sliding Handle Weldment
29	2501441	2	Cap, 2" Sq. Tube
30	2500636	2	Handle Grip
31	2900596	2	Cap Screw, Hex Hd., 3/8-16 x 2-1/2"
32	6048184	1	Front Axle Assembly
33	6048183	1	Screw Feed Assembly

## Front Axle Assembly: 6048184

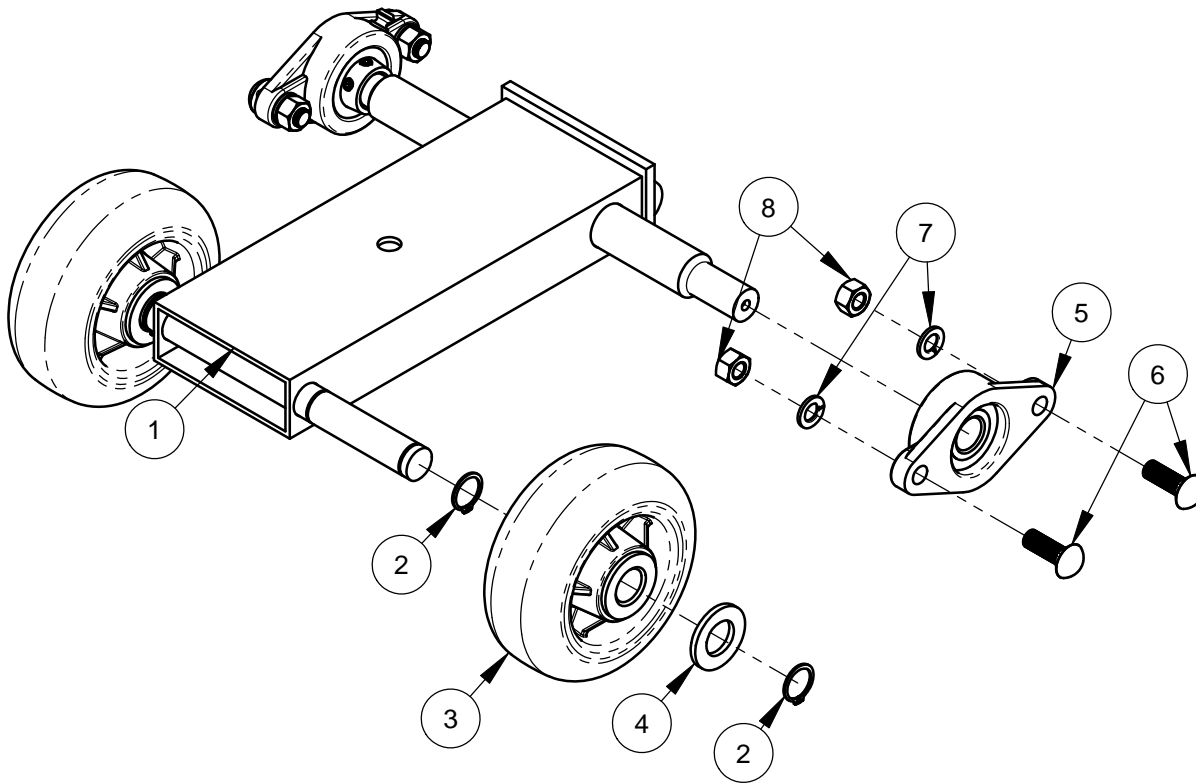

ITEM	PART NO.	QTY.	DESCRIPTION
1	6040212	1	Front Axle Weldment
2	2501186	4	Retaining Ring, External 3/4"
3	2500005	2	Wheel, 5" x 2" x 3/4"
4	2900003	2	Flat Washer, 3/4" SAE
5	2500011	2	Flg Mnt Brg 3/4" Peer UCFT204-12-90
6	2900046	4	Carriage Bolt, 3/8"-16 X 1-1/4"
7	2900321	4	Lock Washer, M10 Split
8	2900304	4	Lock Nut, M10 Nylon

## Screw Feed Assembly #6048183

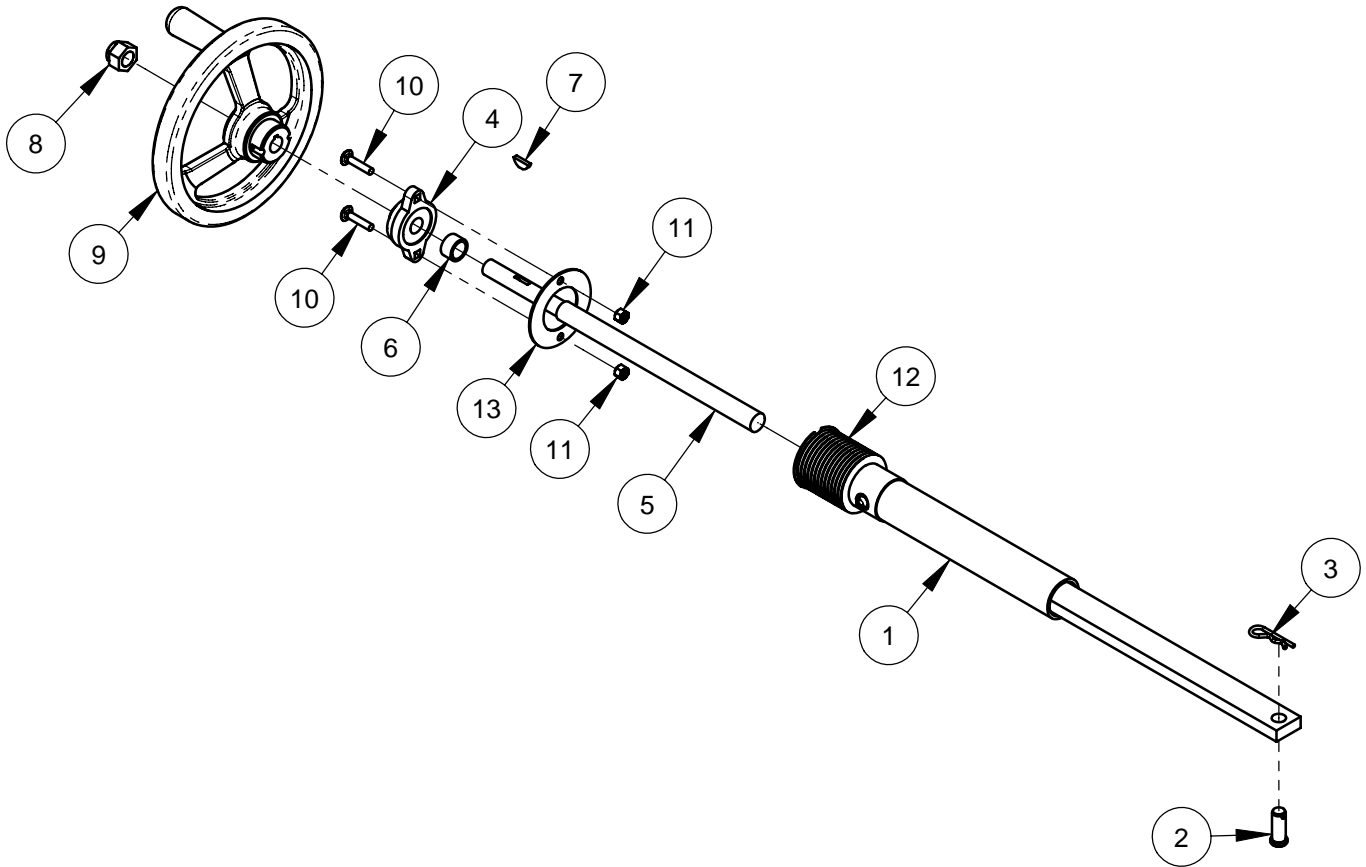

ITEM	PART NO.	QTY	DESCRIPTION
1	6047928	1	Adjustment Shaft W/Grease Fitting
2	2900266	1	Clevis Pin, 1/2 x 1-1/4"
3	2900276	1	Hairpin Cotter, 1/8" x 1/2" to 3/4"
4	2500807	1	Bearing, 5/8", Two Bolt Flange
5	6047929	1	Adjustment Screw
6	6047931	1	Spacer Tube 7/8 x 1/2
7	2900352	1	Woodruff Key, 5/32 x 3/4, #506
8	2900355	1	Lock Nut, 5/8-18, Flex Top
9	2500800	1	Handwheel, 8" x 5/8"
10	2900373	2	Carriage Bolt, 1/4-20 x 1-1/4", GR5
11	2900010	2	Lock Nut, 1/4-20 Nylon
12	6048036	1	Bellow, 8" Long
13	6048038	1	Bellow Mount Washer

# CC1309XL Honda 8HP Engine Assembly, #6049070

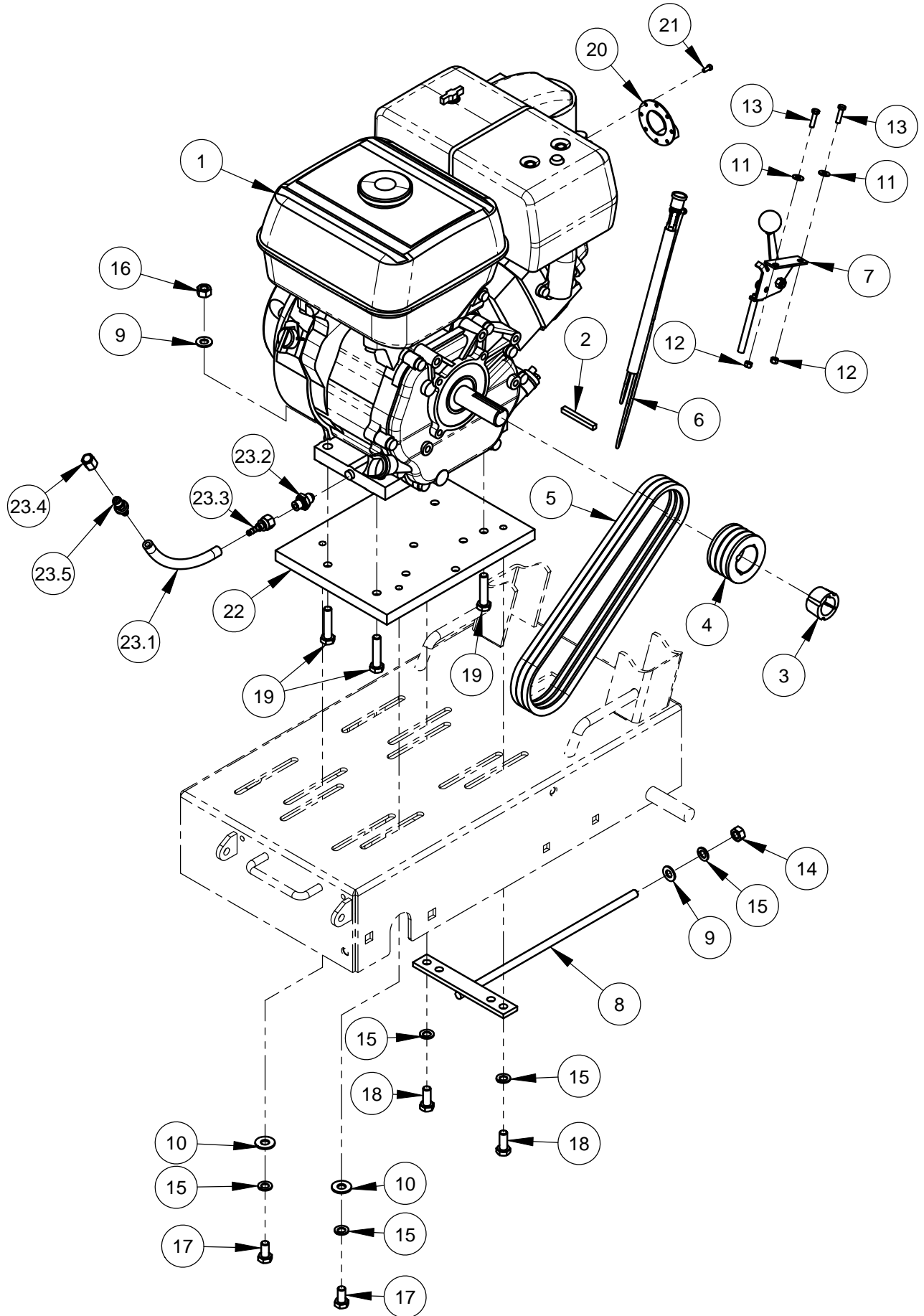



## CC1309XL Honda 8HP Engine Assembly, #6049070

ITEM	PART NO.	QTY.	DESCRIPTION
1	2600160	1	8.0 HP Honda Engine GX270
2	6048134	1	Key, 1/4" Sq. x 2-1/4"
3	2500026	1	Taper Bushing, 1" w/ Set Screws
4	2500022	1	Sheave, 2.65 - 3 Groove
5	2500034	3	V-Belt, 3VX315
6	6048789	1	Wire Harness, Stop Switch (Gas Saw Only)
7	2501565	1	Throttle Control, 15"
8	6040261	1	Belt Adjustment Weldment
9	2900014	5	Flat Washer, 3/8" SAE
10	2900473	2	Flat Washer, 3/8" USS
11	2900016	2	Flat Washer, #10 USS
12	2900301	2	Lock Nut, M5-0.8 Nylon Insert
13	2900309	2	Cap Screw, Hex Hd., M5-0.8 x 20mm
14	2900325	1	Hex Nut, M10
15	2900321	5	Lock Washer, M10 Split
16	2900304	4	Lock Nut, M10-1.5 Nylon Insert
17	2900314	2	Cap Screw, Hex Hd., M10-1.5 x 20mm
18	2900333	2	Cap Screw, Hex Hd., M10-1.5 x 25mm
19	2900317	4	Cap Screw, Hex Hd., M10-1.5 x 45mm
20	2700554	1	Muffler Deflector, 11-13 HP Honda
21	2900206	8	Screw, Self Tapping, #8-32 x 3/8"
22	6048186	1	CC1300 Adaptor Plate
23	6048029	1	Oil Drain Assembly
23.1	6048289	1	1/4" x 6.00" Oil Drain Hose
23.2	3200539	1	Adapter, M12 x 1.5 M to 5/16" Male JIC
23.3	3200540	1	Fitting, 5/16" F. JIC to 1/4" Pushlock
23.4	3200006	1	Cap, 1/4" JIC
23.5	3200040	1	Fitting, 1/4" M. JIC to 1/4" Push Lock

# CC1313XL Honda 11HP Engine Assembly, #6049072

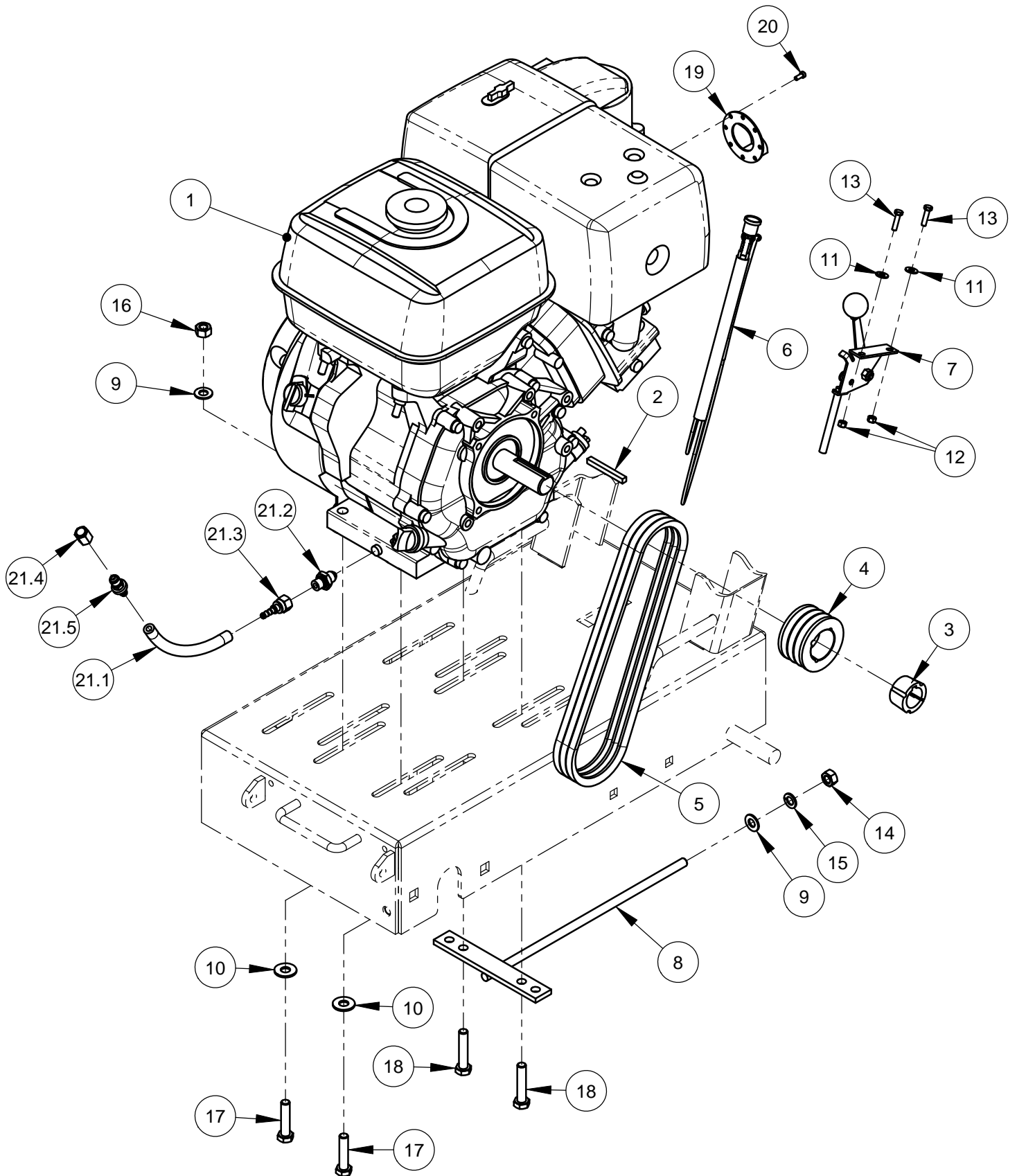

## CC1313XL Honda 11HP Engine Assembly, #6049072

ITEM	PART NO.	QTY.	DESCRIPTION
1	2600116	1	Engine,11 HP Honda GX390
2	6048134	1	Key, 1/4" Sq. x 2-1/4"
3	2500026	1	Taper Bushing, 1" w/ Set Screws
4	2500022	1	Sheave, 2.65 - 3 Groove
5	2500380	3	V-Belt, 3VX300
6	6048789	1	Wire Harness, Stop Switch (Gas Saw Only)
7	2501565	1	Throttle Control, 15"
8	6040261	1	Belt Adjustment Weldment
9	2900014	5	Flat Washer, 3/8" SAE
10	2900473	2	Flat Washer, 3/8" USS
11	2900016	2	Flat Washer, #10 USS
12	2900301	2	Lock Nut, M5-0.8 Nylon Insert
13	2900309	2	Cap Screw, Hex Hd., M5-0.8 x 20mm
14	2900325	1	Hex Nut, M10
15	2900321	1	Lock Washer, M10 Split
16	2900304	4	Lock Nut, M10-1.5 Nylon Insert
17	2900317	2	Cap Screw, Hex Hd., M10-1.5 x 45mm
18	2900318	2	Cap Screw, Hex Hd., M10-1.5 x 50mm
19	2700554	1	Muffler Deflector, 11-13 HP Honda
20	2900206	8	Screw, Self Tapping, #8-32 x 3/8"
21	6048029	1	Oil Drain Assembly
21.1	6048289	1	1/4" x 6.00" Oil Drain Hose
21.2	3200539	1	Adapter, M12 x 1.5 M to 5/16" Male JIC
21.3	3200540	1	Fitting, 5/16" F. JIC to 1/4" Pushlock
21.4	3200006	1	Cap, 1/4" JIC
21.5	3200040	1	Fitting, 1/4" M. JIC to 1/4" Push Lock

**CC1313XL Honda 11HP Engine Assembly**  
**For 20" Blade Guard #6049073**

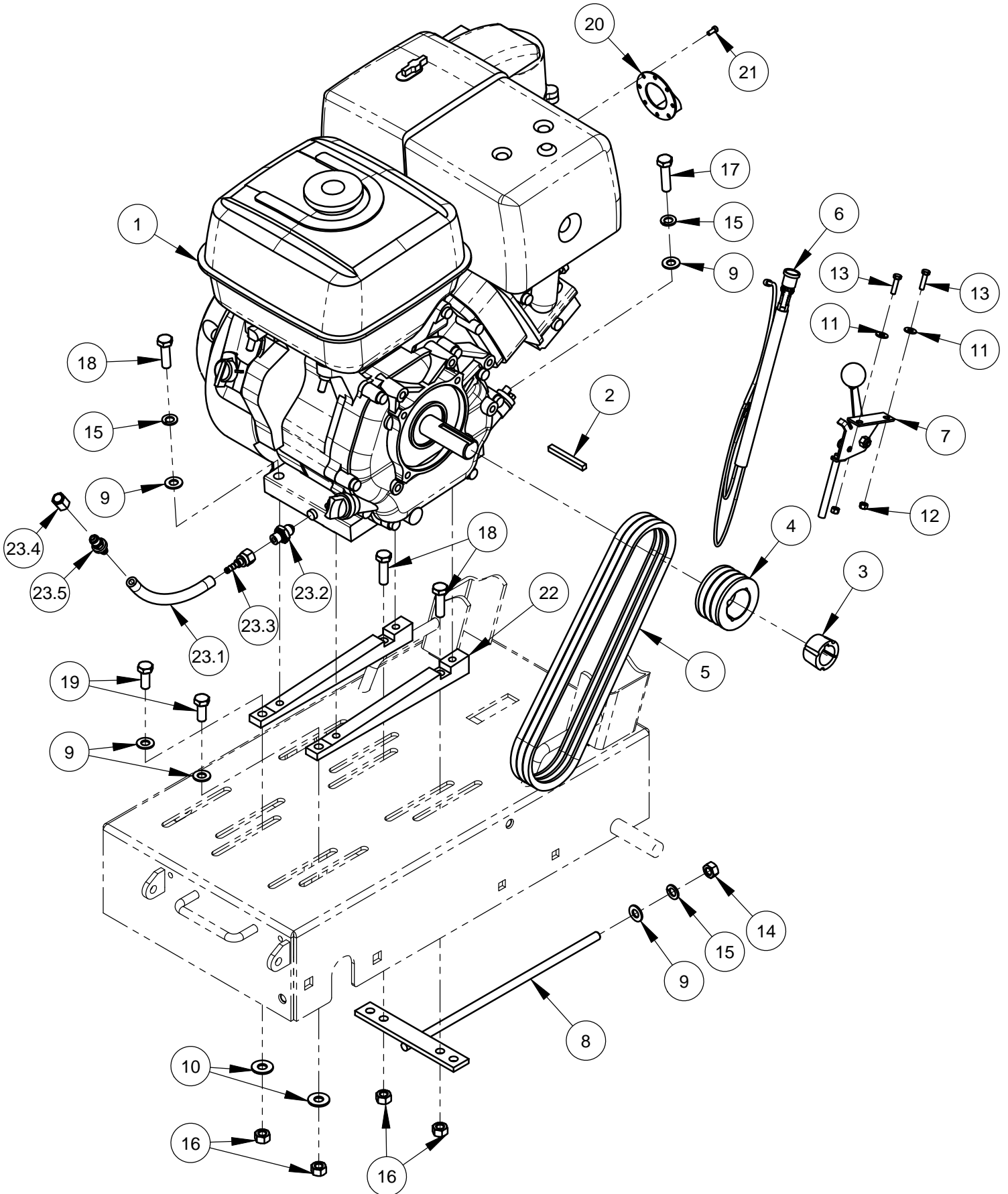

**CC1313XL Honda 11HP Engine Assembly**  
**For 20" Blade Guard #6049073**

ITEM	PART NO.	QTY.	DESCRIPTION
1	2600116	1	Engine,11 HP Honda GX390
2	6048134	1	Key, 1/4" Sq. x 2-1/4"
3	2500026	1	Taper Bushing, 1" w/ Set Screws
4	2500022	1	Sheave, 2.65 - 3 Groove
5	2500034	3	V-Belt, 3VX315
6	6048789	1	Wire Harness, Stop Switch (Gas Saw Only)
7	2501565	1	Throttle Control, 15"
8	6040261	1	Belt Adjustment Weldment
9	2900014	7	Flat Washer, 3/8" SAE
10	2900473	2	Flat Washer, 3/8" USS
11	2900016	2	Flat Washer, #10 USS
12	2900301	2	Lock Nut, M5-0.8 Nylon Insert
13	2900309	2	Cap Screw, Hex Hd., M5-0.8 x 20mm
14	2900325	1	Hex Nut, M10
15	2900321	5	Lock Washer, M10 Split
16	2900304	4	Lock Nut, M10-1.5 Nylon Insert
17	2900316	2	Cap Screw, Hex Hd., M10-1.5 x 40mm
18	2900315	4	Cap Screw, Hex Hd., M10-1.5 x 35mm
19	2900333	2	Cap Screw, Hex Hd., M10-1.5 x 25mm
20	2700554	1	Muffler Deflector, 11-13 HP Honda
21	2900206	8	Screw, Self Tapping, #8-32 x 3/8"
22	6043196	2	Motor Mount Wedge
23	6048029	1	Oil Drain Assembly
23.1	6048289	1	1/4" x 6.00" Oil Drain Hose
23.2	3200539	1	Adapter, M12 x 1.5 M to 5/16" Male JIC
23.3	3200540	1	Fitting, 5/16" F. JIC to 1/4" Pushlock
23.4	3200006	1	Cap, 1/4" JIC
23.5	3200040	1	Fitting, 1/4" M. JIC to 1/4" Push Lock

# CC1309XL Robin 9HP Engine Assembly, #6049071

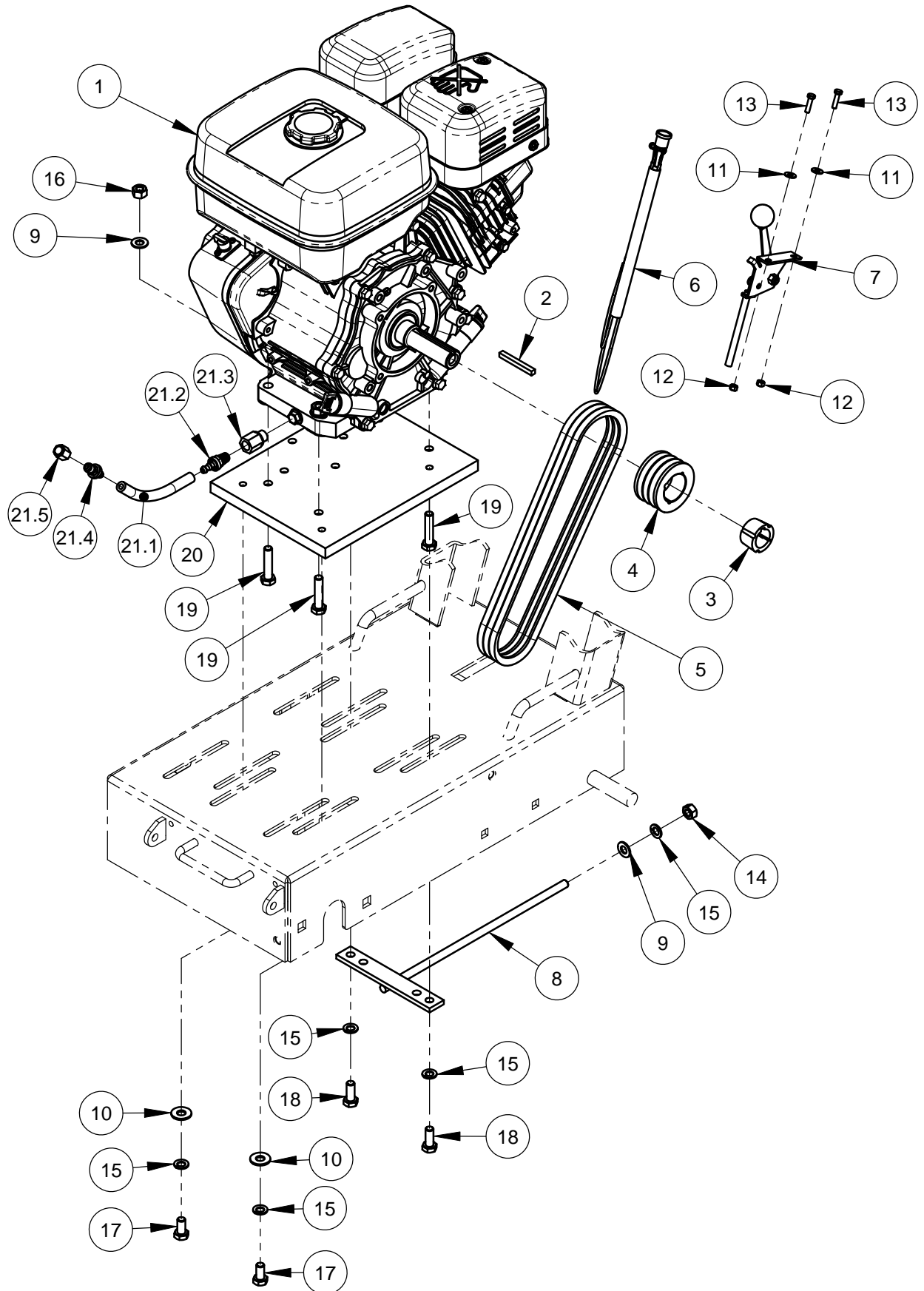

**CC1309XL Robin 9HP Engine Assembly, #6049071**

ITEM	PART NO.	QTY.	DESCRIPTION
1	2600368	1	9.0 HP Robin Engine EX270
2	6048134	1	Key, 1/4" Sq. x 2-1/4"
3	2500026	1	Taper Bushing, 1" w/ Set Screws
4	2500022	1	Sheave, 2.65 - 3 Groove
5	2500034	3	V-Belt, 3VX315
6	6048789	1	Wire Harness, Stop Switch (Gas Saw Only)
7	2501676	1	Throttle Control, 15.75"
8	6040261	1	Belt Adjustment Weldment
9	2900014	5	Flat Washer, 3/8" SAE
10	2900473	2	Flat Washer, 3/8" USS
11	2900016	2	Flat Washer, #10 USS
12	2900301	2	Lock Nut, M5-0.8 Nylon Insert
13	2900309	2	Cap Screw, Hex Hd., M5-0.8 x 20mm
14	2900325	1	Hex Nut, M10
15	2900321	5	Lock Washer, M10 Split
16	2900304	4	Lock Nut, M10-1.5 Nylon Insert
17	2900314	2	Cap Screw, Hex Hd., M10-1.5 x 20mm
18	2900333	2	Cap Screw, Hex Hd., M10-1.5 x 25mm
19	2900317	4	Cap Screw, Hex Hd., M10-1.5 x 45mm
20	6048822	1	CC1309 XL Adaptor Plate
21	6048043	1	Oil Drain Hose Assembly
21.1	6048032	1	Oil Drain Hose, 1/4" ID X 9" Long
21.2	3201270	1	Fitting, 1/4" M. Pipe to 1/4" Pushlock
21.3	3201269	1	Adapter, M14x1.5 M. to 1/4" F. Pipe
21.4	3200040	1	Fitting, 1/4" M. JIC to 1/4" Push Lock
21.5	3200006	1	Cap, 1/4" JIC

## Blade Shaft Assembly, #6041041

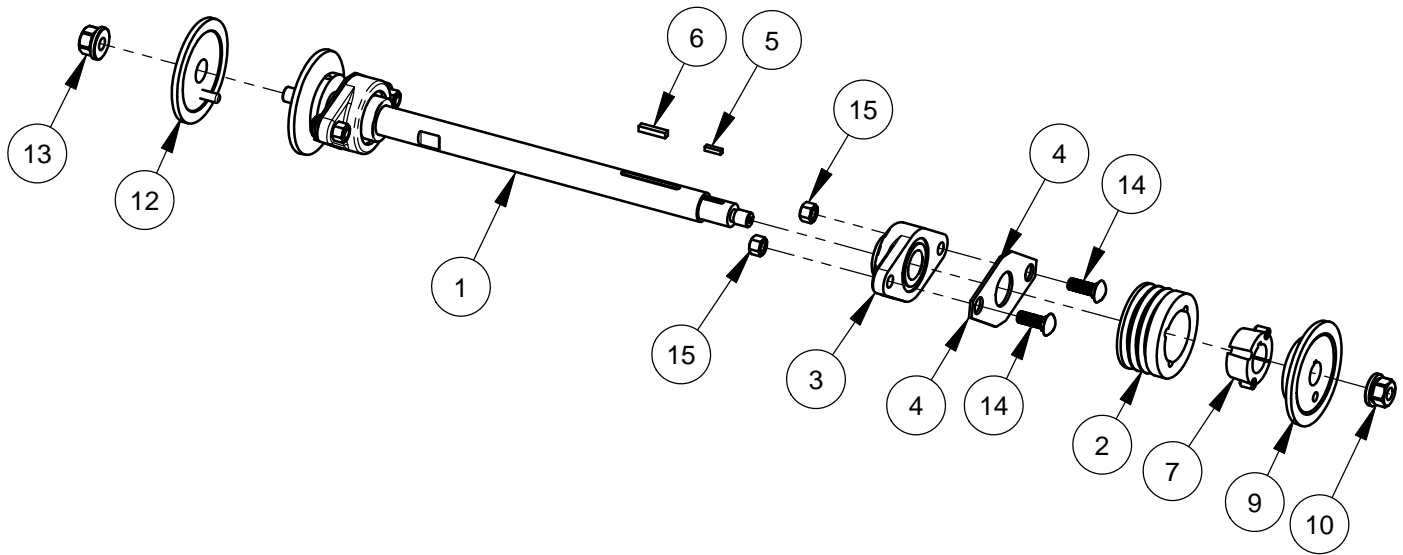

ITEM	PART NO.	QTY	DESCRIPTION
1	6048866	1	Blade Shaft
2	2500025	1	Sheave, 3.65-3 Groove
3	2500576	2	Flange Block Bearing, 1-1/4"
4	6048037	2	Bearing Spacer
5	6048018	2	Key, 3/16" Sq. x 3/4"
6	6010169	1	Key, 1/4" Sq. x 1-1/4"
7	2500337	1	Taper Bushing, 1-1/4"
9	6048008	2	Inner Flange 4-1/2"
10	2900065	1	Flange Nut, 5/8-11 R.H.
12	6048009	1	Outer Flange, 4-1/2" w/ Pin
13	2900066	1	Flange Nut, 5/8-11 L.H.
14	2900046	4	Carriage Bolt, 3/8"-16 X 1-1/4"
15	2900327	4	Lock Nut, M12-1.75 Nylon Insert



**14" Blade Guard Assembly**  
**#6048912**

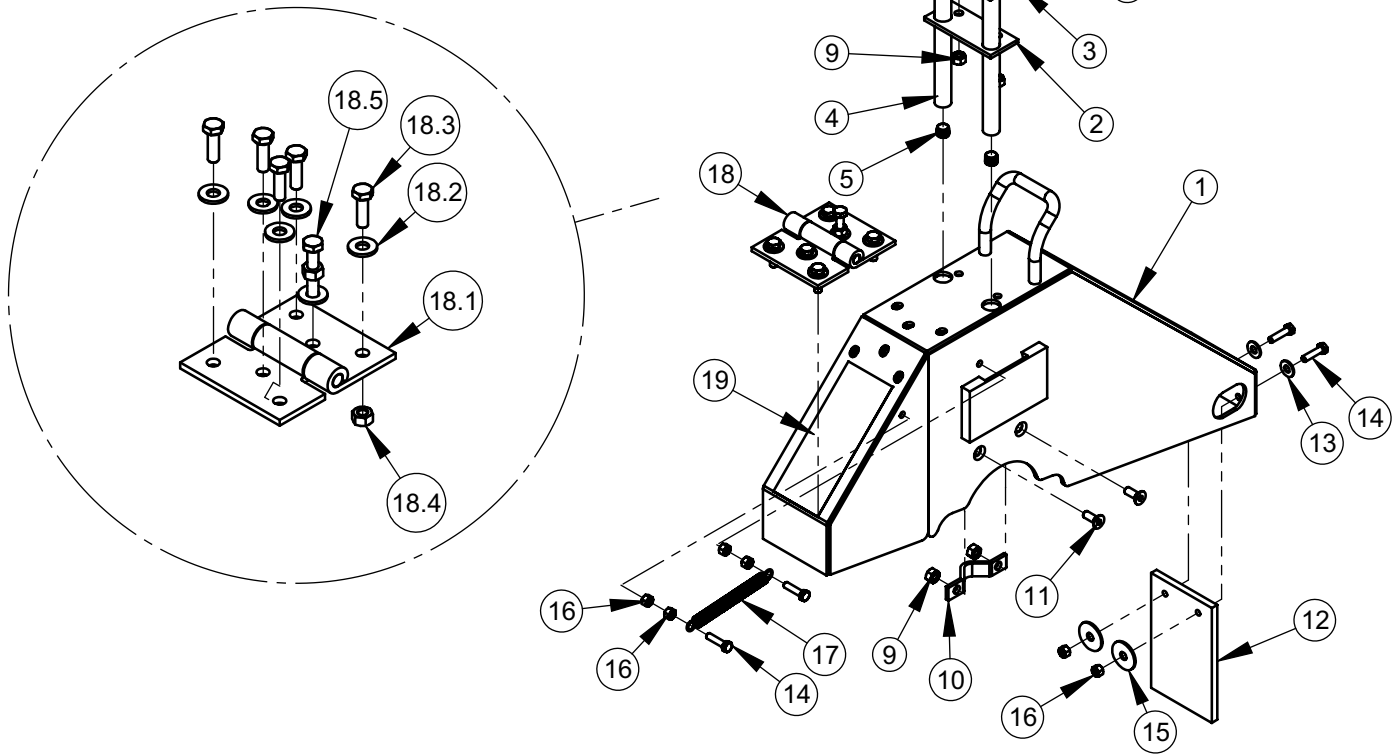

ITEM	PART NO.	QTY.	DESCRIPTION
1	6048911	1	14" Blade Guard
2	2500829	1	Water Manifold Gasket
3	6048123	1	Water Manifold
4	6048283	2	Water Tube for 14" Guard
5	3200001	3	Plug, 1/8" NPT
6	3200002	1	Fitting, 3/8" M. Pipe to 3/4" M. Garden
7	2900009	2	Flat Washer, 1/4" SAE
8	2900244	2	Cap Screw, Hex Hd., M6 x 45mm
9	2900302	6	Lock Nut, M6 Nylon
10	6048155	2	Water Tube Clamp
11	2900308	4	Cap Screw, Flat Hd. Soc., M6 x 16mm
12	6048039	1	Splash Flap
13	2900016	2	Flat Washer, #10 USS
14	2900309	4	Cap Screw, Hex Hd., M5 x 20mm
15	2900083	2	Fender Washer, 1/4" I.D. x 1-1/4" O.D.
16	2900301	6	Lock Nut, M5 Nylon
17	2500066	1	Spring, 3/8 X .055 X 3"
18	6048026	1	Hinge Assy., Metric Fasteners
18.1	2500270	1	Blade Guard Hinge
18.2	2900009	6	Flat Washer, 1/4" SAE
18.3	2900310	5	Cap Screw, Hex Hd., M6 x 20mm
18.4	2900302	7	Lock Nut, M6 Nylon
18.5	2900312	1	Cap Screw, Hex Hd., M6 x 35mm
19	1800001	1	Warning Label

## 18" Blade Guard Assembly #6048910

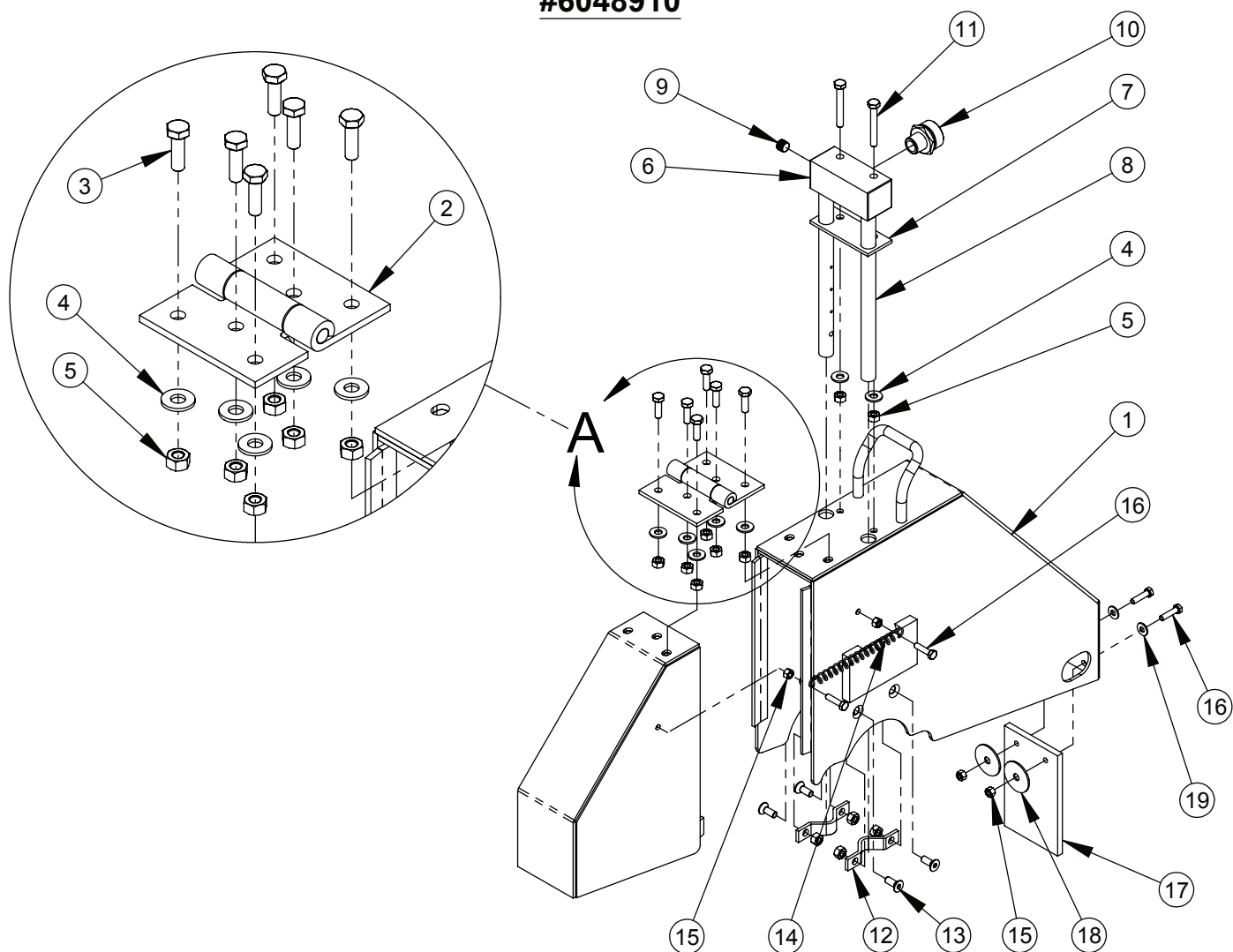

ITEM	PART NO.	QTY.	DESCRIPTION
1	6048909	1	18" Blade Guard Assembly (Slip-On Style)
2	2500270	1	Blade Guard Hinge
3	2900310	6	Cap Screw, Hex Hd., M6 x 20mm
4	2900009	8	Flat Washer, 1/4" SAE
5	2900302	12	Lock Nut, M6 Nylon
6	6048123	1	Water Manifold
7	2500829	1	Water Manifold Gasket
8	6048243	2	Water Tube for 18" Guard
9	3200001	1	Plug, 1/8" NPT
10	3200002	1	Fitting, 3/8" M. Pipe to 3/4" M. Garden
11	2900244	2	Cap Screw, Hex Hd., M6 x 45mm
12	6048155	2	Water Tube Clamp
13	2900308	4	Cap Screw, Flat Hd. Soc., M6 x 16mm
14	2500067	1	Spring, 3/8" x 4"
15	2900301	4	Lock Nut, M5 Nylon
16	2900309	4	Cap Screw, Hex Hd., M5 x 20mm
17	6048039	1	Splash Flap
18	2900083	2	Fender Washer, 1/4" x 1-1/4"
19	2900016	2	Flat Washer, #10 USS

**20" Blade Guard Assembly**  
**#6048904**

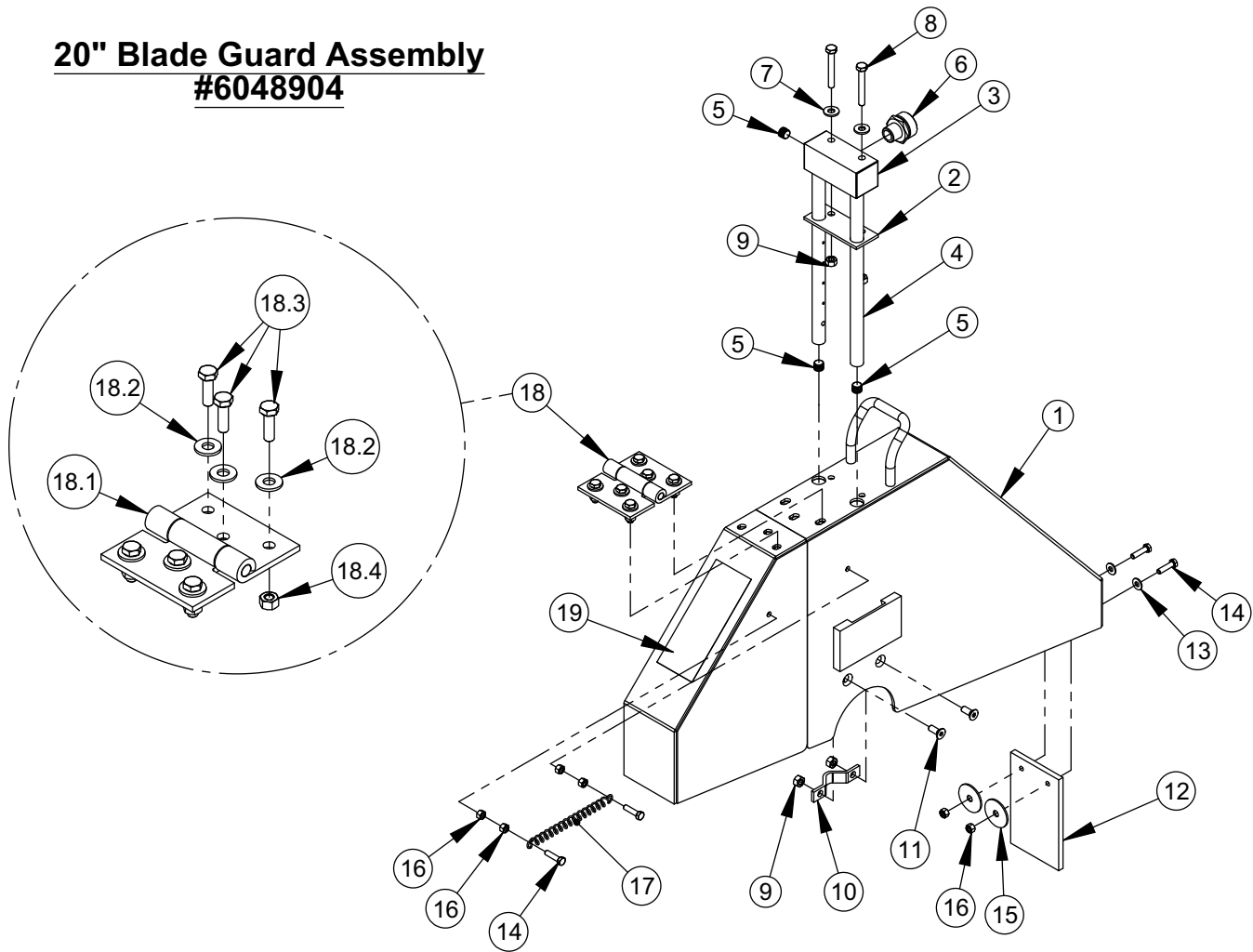

ITEM	PART NO.	QTY.	DESCRIPTION
1	6048905	1	20" Blade Guard
2	2500829	1	Water Manifold Gasket
3	6048123	1	Water Manifold
4	6010085	2	Water Tube for 20" Guard
5	3200001	3	Plug, 1/8" NPT
6	3200002	1	Fitting, 3/8" M. Pipe to 3/4" M. Garden
7	2900009	2	Flat Washer, 1/4" SAE
8	2900244	2	Cap Screw, Hex Hd., M6 x 45mm
9	2900302	6	Lock Nut, M6 Nylon
10	6048155	2	Water Tube Clamp
11	2900308	4	Cap Screw, Flat Hd. Soc., M6 x 16mm
12	6048039	1	Splash Flap
13	2900016	2	Flat Washer, #10 USS
14	2900309	4	Cap Screw, Hex Hd., M5 x 20mm
15	2900083	2	Fender Washer, 1/4" x 1-1/4"
16	2900301	6	Lock Nut, M5 Nylon
17	2500067	1	Spring, 3/8" x 4"
18	6048027	1	Hinge Assy., Metric Fasteners
18.1	2500270	1	Blade Guard Hinge
18.2	2900009	6	Flat Washer, 1/4" SAE
18.3	2900310	6	Cap Screw, Hex Hd., M6 x 20mm
18.4	2900302	6	Lock Nut, M6 Nylon
19	1800001	1	Warning Label

**Pointer Assembly - 6048080**  
**- 6047994 (10HP Electric)**

ITEM	PART NO.	QTY	DESCRIPTION
1	6048069	1	Pointer Bar - Straight
2	6048070	1	Pointer Bar - Offset
3	2500624	1	Wheel, 3"
4	2900018	1	Lock Nut, 3/8-16 Nylon
5	2900321	1	Lock Washer, M10 Split
6	2900033	1	Hex Nut, 3/8-16
7	2900304	2	Lock Nut, M10 Nylon
8	2900333	2	Cap Screw, Hex Hd., M10 x 25mm
9	6048078	1	Rope, 1/4 x 78"
10	3200221	3	Pinch Clamp, Two Ear
11	2900032	1	Pointer Rod
	2900743	1	Ponter Rod (10HP Electric)

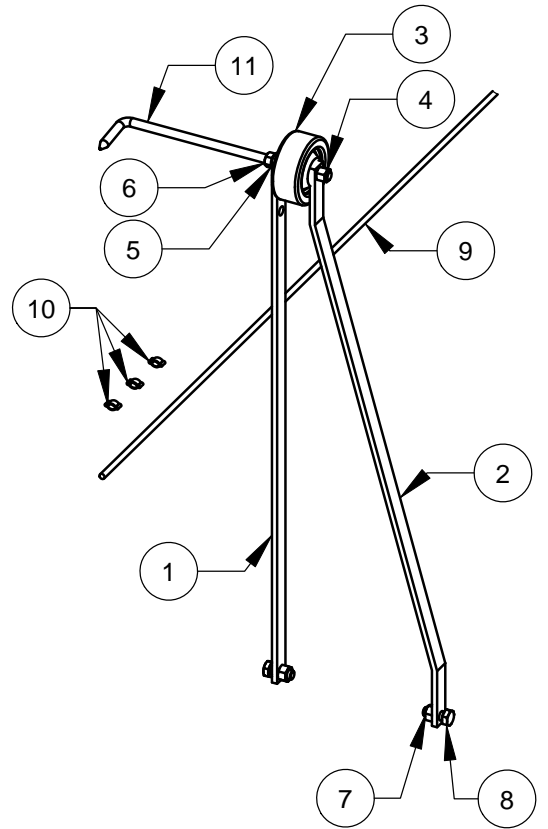

**Pointer Assembly - 6048157 (Upcut)**

ITEM	PART NO.	QTY.	DESCRIPTION
1	6048126	1	Bar, Pointer
2	2900014	1	Flat Washer, 3/8" SAE
3	2900315	1	Cap Screw, Hex Hd., M10 x 35mm
4	2900304	1	Lock Nut, M10 Nylon

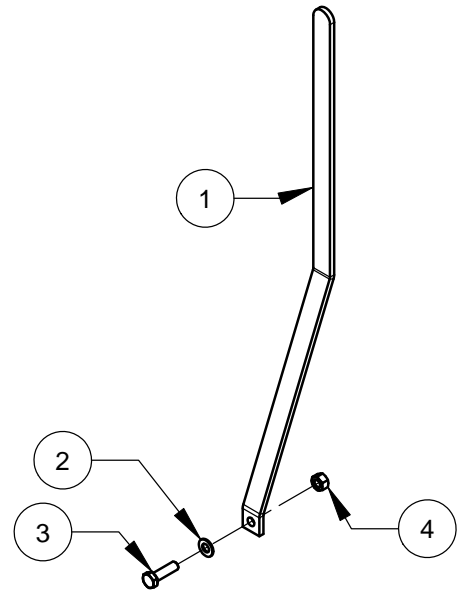

**WATER TANK OPTION: 6049060**

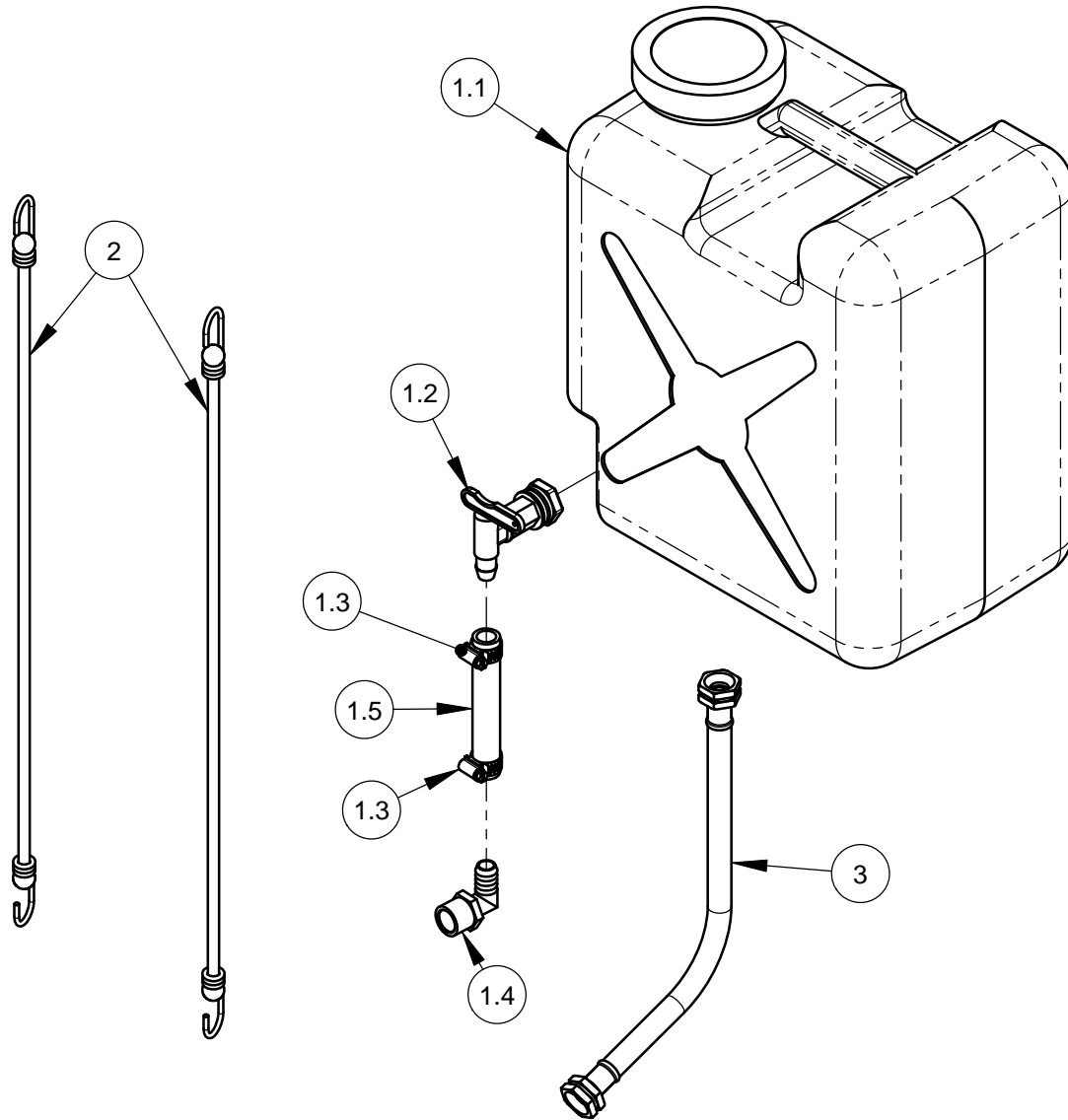

**MOUNTS TO LIFT BAR.**

ITEM	PART NO.	QTY.	DESCRIPTION
1	6049062	1	Water Tank W/Hose Assy.
1.1	6048299	1	Water Tank Assy., 7-1/2 Gallon
1.2	2505095	1	Petcock
1.3	3200016	2	Hose Clamp #8
1.4	3202085	1	3/4" MPT X 5/8" Hose Barb
1.5	6049061	1	5/8" x 5-1/4" Clear Hose
2	2500586	2	Tiedown, Elastic, 28"
3	6011055	1	Water Hose Assembly, 30" Long



Intentionally Blank

## EQUIPMENT AND PARTS WARRANTY

Diamond Products warrants all equipment manufactured by it against defects in workmanship or materials for a period of one (1) year from the date of shipment to Customer.

The responsibility of Diamond Products under this Warranty is limited to replacement or repair of defective parts at Diamond Products' Elyria, Ohio factory, or at a point designated by it, of such parts as shall appear to us upon inspection at such parts, to have been defective in material or workmanship, with expense for transportation and labor borne by Customer.

In no event shall Diamond Products be liable for consequential or incidental damages arising out of the failure of any Product to operate properly.

Integral units such as engines, electric motors, batteries, transmissions, etc., are excluded from this Warranty and are subject to the prime manufacturer's warranty.

**THIS WARRANTY IS IN LIEU OF ALL OTHER WARRANTIES, EXPRESSED OR IMPLIED, AND ALL SUCH OTHER WARRANTIES ARE HEREBY DISCLAIMED.**



333 Prospect Street, Elyria, Ohio 44035  
(440) 323-4616 • (800) 321-5336 • Fax (440) 323-8689  
[www.diamondproducts.com](http://www.diamondproducts.com)





CONCRETE SAW  
PARTS LIST

**MODEL**  
**CC1300XL**  
**Electric Units**

August 2014

Part 1801809

### RECOMMENDED POWER CORD GAUGE

HORSE POWER	PHASE	VOLTS	AMPS	50 Ft. CORD	100 Ft. CORD	150 Ft. CORD	200 Ft. CORD
5hp	1ph	230v	23A	#10	#8	#6	#4
5hp	3ph	230v	12A	#14	#12	#10	#8
5hp	3ph	460v	6A	#14	#14	#12	#10
7.5hp	1ph	230v	33A	#8	#8	#6	#4
10hp	3ph	230v	24A	#10	#8	#6	#4
10hp	3ph	460v	12A	#14	#12	#10	#8
20hp	3ph	230v	52A	#6	#6	#4	#2
20hp	3ph	460v	26A	#10	#8	#6	#4
25hp	3ph	230v	58A	#6	#6	#4	#2
25hp	3ph	460v	29A	#10	#8	#6	#4
30hp	3ph	230v	74A	#6	#4	#2	#1
30hp	3ph	460v	37A	#8	#6	#4	#2
40hp	3ph	460v	48A	#8	#6	#4	#2
50hp	3ph	460v	62A	#4	#4	#2	#0

CAUTION: Use of a wire gauge that is too small will cause loss of power or overheating and will damage the electric motor.

# GENERAL SAFETY WARNINGS AND PRECAUTIONS

## PERSONAL SAFETY

- Read and understand all operating instructions before attempting to operate the saw.
- Always wear safety approved hearing, eye, head and respiratory protection.
- Always wear sturdy boots with non-slip soles to ensure proper footing. Use of steel toed safety boots is recommended.
- Due to the nature of concrete cutting, sparks may be generated therefore never wear clothing that is made of flammable material.
- Know how to stop the saw quickly in case of emergency.
- Keep all parts of your body away from the blade and all other moving parts.
- Use caution and follow all instructions when loading and unloading the saw.
- Electric Units: disconnect power cord prior to changing the blade or performing maintenance.

## BLADE SAFETY

- Examine cutting blades before each use. Blade should have no cracks, nicks, or flaws. The center hole must be undamaged. Use only blades recommended for your particular model saw.
- The saw should only be used for cutting material that is specified on each cutting blade. Read the instructions provided with each blade to determine which material the blade is designed to cut.
- Use only reinforced abrasive blades or steel centered diamond blades manufactured for use on concrete saws.
- Inspect blade flanges for damage, excessive wear and cleanliness before mounting the blade. The blade must fit snugly on the clean, undamaged blade shaft.
- Observe the specified maximum speed of the blade. Never use a blade that has a lower maximum operating speed than the blade shaft speed.
- The ignition governor is designed to limit the maximum no-load engine speed. Speeds in excess of that may cause the blade to exceed the maximum blade speed. Do not operate the unit at speeds greater than the maximum blade speed.
- Always keep guards in place and never allow the blade exposure on the guard to exceed 180 degrees. Repair or replace damaged guards immediately.
- Never expose anyone to the direct line of the blade.
- Make sure that the blade does not come in contact with the ground or any other surface when transporting the saw.

## GENERAL SAW SAFETY

- The saw must never be left unattended when the engine is running.
- Keep both hands on the handles when operating the saw.
- Use caution and slow speed when using the self propelled drive to move the saw up or down ramps or when loading and unloading from trucks or trailers. When going down ramps, DRIVE the saw forward slowly. When going up ramps, BACK the saw in reverse slowly. Always position yourself on the high side of the slope.
- Gas Units: never operate the saw if there is a fuel leak.

## CUTTING / WORK AREA SAFETY

- Never operate the saw in any application or job in which you are not trained or supervised.
- Always ensure that the work area does not contain any buried or embedded electrical lines, gas lines or water lines. Ensure that all electric, gas and water lines that may be buried or embedded in the ground, floor, walls or ceilings are shut off prior to cutting.
- Keep bystanders and animals out of the work area.
- Do not operate the saw in areas which contain combustible material or fumes. Sparks may occur from cutting that could cause a fire or explosion.
- Gas Units: operate the saw only in well ventilated areas. Engine exhaust contains carbon monoxide which can cause loss of consciousness and death.
- Gas Units: observe all safety regulations for the safe handling of fuel. Store fuel in appropriate safety containers. Shut off the engine and allow it to cool prior to fueling. Wipe off any spilled fuel. Always move away from the fueling area prior to starting saw.

***Concrete cutting as all construction work is inherently dangerous!***

***Failure to comply with the preceding warnings could result in serious bodily injury!***



## Table of Contents

<u>Description</u>	<u>Page No.</u>
Common Parts.....	6
Front Axle Assembly.....	8
Screw Feed Assembly.....	9
Motor Assembly, 5HP, 230V, 1 Phase.....	10
Motor Assembly, 5HP, 230V, 3 Phase.....	12
Motor Assembly, 5HP, 460V, 3 Phase.....	14
Motor Assembly, 10HP, 230V, 3 Phase.....	16
Motor Assembly, 10HP, 460V, 3 Phase .....	18
Motor Assembly, 10HP, 575V, 3 Phase .....	20
Starter Box Assembly, 3 Phase, 220-240V.....	22
Starter Box Assembly, 3 Phase, 415-480V.....	23
Starter Box Assembly, 3 Phase, 550-600V.....	25
Starter Box, 220-240V .....	26
Starter Box, 415-480V .....	28
Starter Box, 550-600V .....	30
Blade Shaft Assembly.....	32
Blade Shaft Assembly (10HP, 230/460V Units) .....	33
Blade Shaft Assembly (10HP, 575V Units) .....	34
14" Blade Guard Assembly .....	35
18" Blade Guard Assembly .....	36
20" Blade Guard Assembly .....	37
Pointer Assembly .....	38
Pointer Assembly (10HP Units).....	39
Warranty.....	Rear Cover

# 6090147 CC1300 XL COMMON PARTS

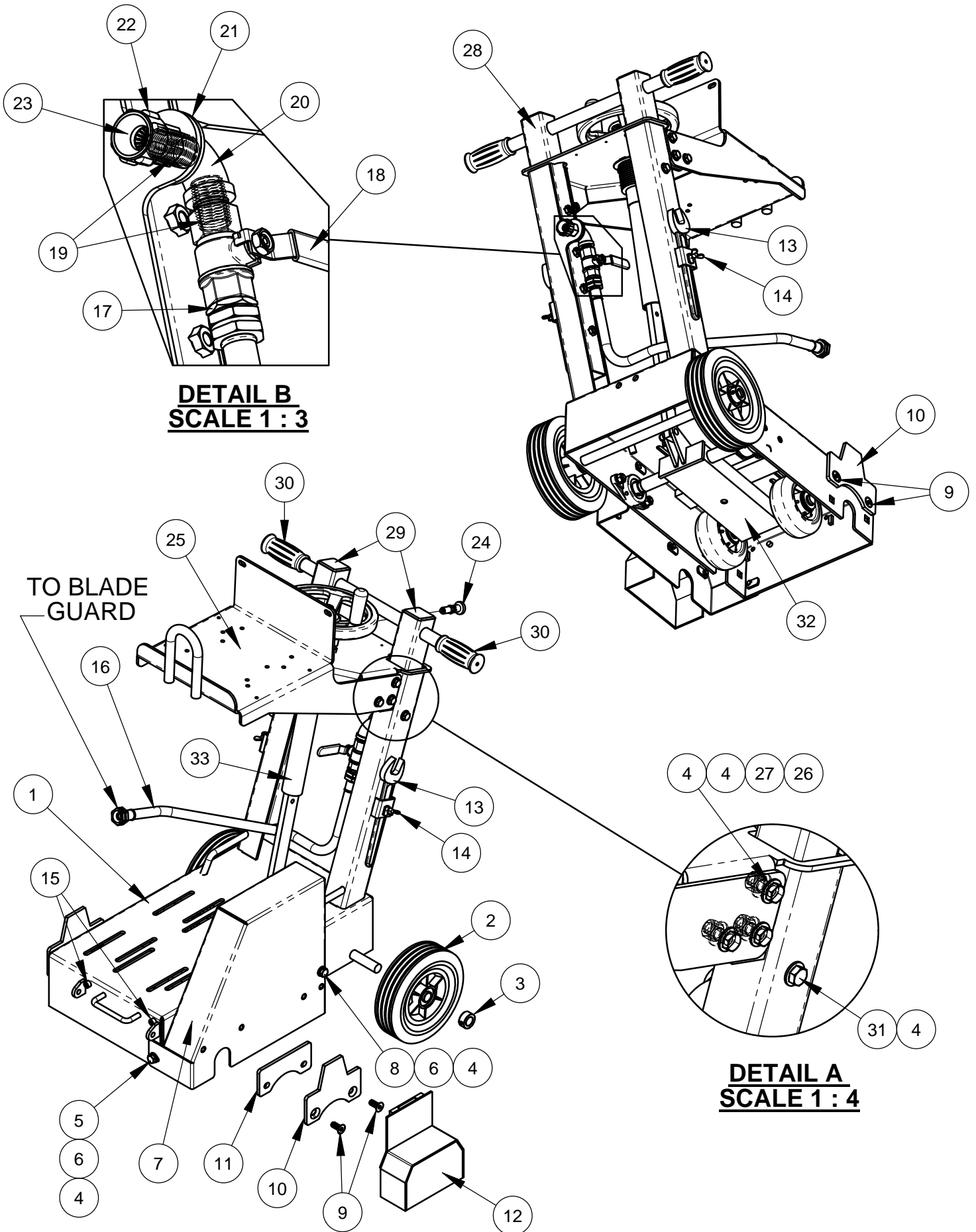

**CC1300XL COMMON PARTS - 6090147 (Regular Cut)**  
**- 6048877 (Upcut)**

ITEM	PART NO.	Default /QTY.	DESCRIPTION
1	6048181	1	Frame Weldment (Regular Cut)
	6048269	1	Frame Weldment (Upcut)
2	2501439	2	Wheel, 8 x 2 x 3/4"
3	2400615	2	Set Collar, 3/4"
4	2900014	16	Flat Washer, 3/8" SAE
5	2900314	1	Cap Screw, Hex Hd., M10-1.5 x 20mm
6	2900321	2	Lock Washer, M10 Split
7	6048001	1	Belt Guard (Regular Cut)
	6048149	1	Belt Guard (Upcut)
8	2900320	1	Cap Screw, Hex Hd., M10-1.5 x 100mm
9	2900744	4	Capscrew, Flat Hd., M10 x 25mm
10	6048908	2	Tapered Guard Mount
11	6048915	1	Tapered Guard Mount Spacer
12	6048906	1	Shaft Guard
13	2500256	2	Wrench Head
14	2900307	2	Wing Screw, M6 x 16mm
15	2900980	2	Capscrew, Soc. Hd., M8 X 10mm
16	6011055	1	Water Hose Assembly, 30" Long
17	3200155	1	Fitting, 1/2" M. Pipe to 3/4" M. Garden
18	3200027	1	Water Valve
19	3200008	2	Close Nipple, 1/2" NPT
20	3200209	1	Pipe Elbow, 1/2" Female
21	2900425	1	Flat Washer, 7/8" SAE
22	3200022	1	Fitting, 1/2" F. Pipe to 3/4" F. Garden
23	3200025	1	Hose Filter Washer
24	2400138	1	Indexing Plunger 1/2-13
25	6030318	1	Lift Bar Assembly
26	2900018	6	Lock Nut, 3/8-16 Nylon
27	2900005	6	Cap Screw, Hex Hd., 3/8-16 x 1"
28	6040213	1	Sliding Handle Weldment
29	2501441	2	Cap, 2" Sq. Tube
30	2500636	2	Handle Grip
31	2900596	2	Cap Screw, Hex Hd., 3/8-16 x 2-1/2"
32	6048184	1	Front Axle Assembly
33	6048183	1	Screw Feed Assembly

## 6048184 Front Axle Assembly

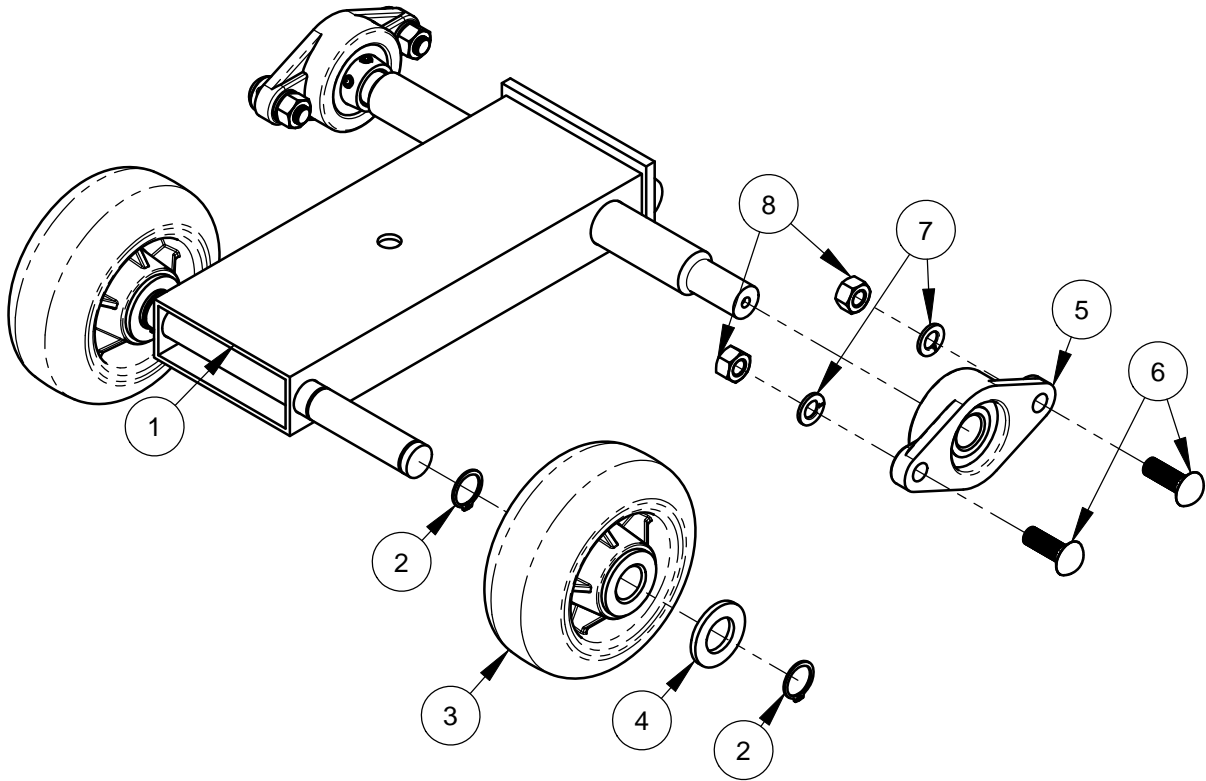

ITEM	PART NO.	QTY.	DESCRIPTION
1	6040212	1	Front Axle Weldment
2	2501186	4	Retaining Ring, External 3/4"
3	2500005	2	Wheel, 5" x 2" x 3/4"
4	2900003	2	Flat Washer, 3/4" SAE
5	2500011	2	Flg Mnt Brg 3/4" Peer UCFT204-12-90
6	2900324	4	Carriage Bolt, M10-1.75 x 30
7	2900321	4	Lock Washer, M10 Split
8	2900304	4	Lock Nut, M10-1.5 Nylon Insert



## Screw Feed Assembly #6048183

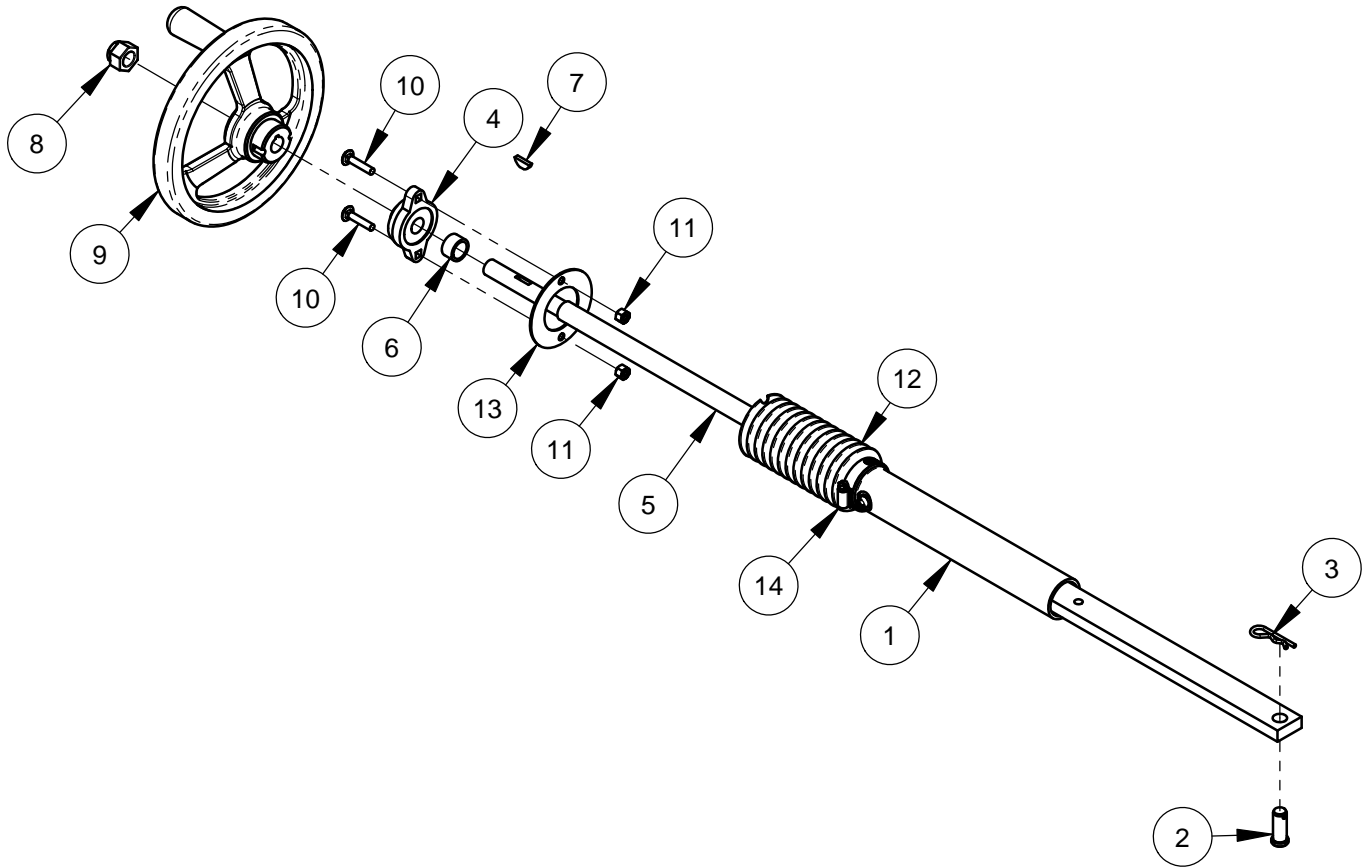

ITEM	PART NO.	QTY	DESCRIPTION
1	6047928	1	Adjustment Shaft W/Grease Fitting
2	2900266	1	Clevis Pin, 1/2 x 1-1/4"
3	2900276	1	Hairpin Cotter, 1/8" x 1/2" to 3/4"
4	2500807	1	Bearing, 5/8", Two Bolt Flange
5	6047929	1	Adjustment Screw
6	6047931	1	Spacer Tube 7/8 x 1/2
7	2900352	1	Woodruff Key, 5/32 x 3/4, #506
8	2900355	1	Lock Nut, 5/8-18, Flex Top
9	2500800	1	Handwheel, 8" x 5/8"
10	2900373	2	Carriage Bolt, 1/4-20 x 1-1/4", GR5
11	2900010	2	Lock Nut, 1/4-20 Nylon
12	6048036	1	Bellow, 5-1/2"
13	6048038	1	Bellow Mount Washer
14	3202142	1	Hose Clamp #24

**6041347 CC1300 XL ELECTRIC MOTOR OPTION, 5HP, 230V, 1-PHASE**

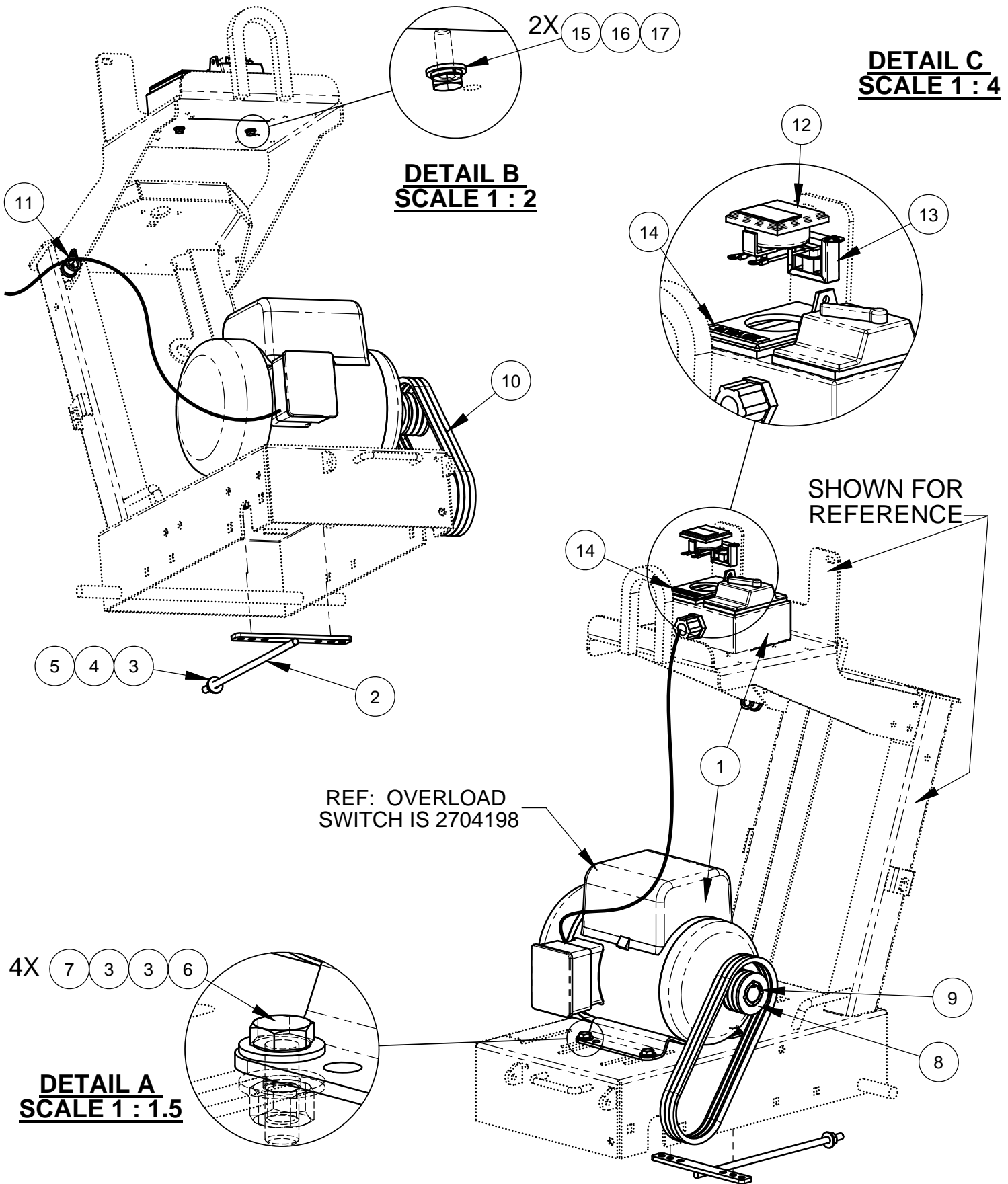

6041347 CC1300 XL ELECTRIC MOTOR OPTION, 5HP, 230V, 1-PHASE

ITEM	PART NO.	QTY.	DESCRIPTION
1	2600278	1	Motor, 5HP, 230V, 1 Ph, W/Switch Box
2	6040261	1	Belt Adjustment Weldment
3	2900473	9	Flat Washer, 3/8" USS
4	2900321	1	Lock Washer, M10 Split
5	2900325	1	Hex Nut, M10-1.5
6	2900223	4	Cap Screw, Hex Hd., M10-1.5 x 30mm
7	2900304	4	Lock Nut, M10-1.5 Nylon Insert
8	2500022	1	Sheave, 2.65 - 3 Groove
9	2500027	1	Taper Bushing, 1-1/8" W/ Setscrews & Key
10	2500380	3	V-Belt, 3VX300
11	2801151	1	Hose Clamp, 3/4" x 3/4" Wide
12	2800253	1	Ampmeter, 0-40 Amp, AC
13	2800085	1	AC Current Transformer
14	1800810	1	Voltage Label, 230V
15	2900009	2	Flat Washer, 1/4" SAE
16	2900024	2	Lock Washer, 1/4" Split
17	2900144	2	Cap Screw, Hex Hd., 1/4-20 x 3/4"
18	6048181	1	Frame Weldment (Regular Cut)
19	6030318	1	Lift Bar Assembly

WITH UPCUT FRAME,6048269, REVERSE MOTOR MOUNTING.

6043436 CC1300XL ELECTRIC MOTOR OPTION, 5HP, 230V, 3-PHASE

**DETAIL B**  
**SCALE 1 : 4**

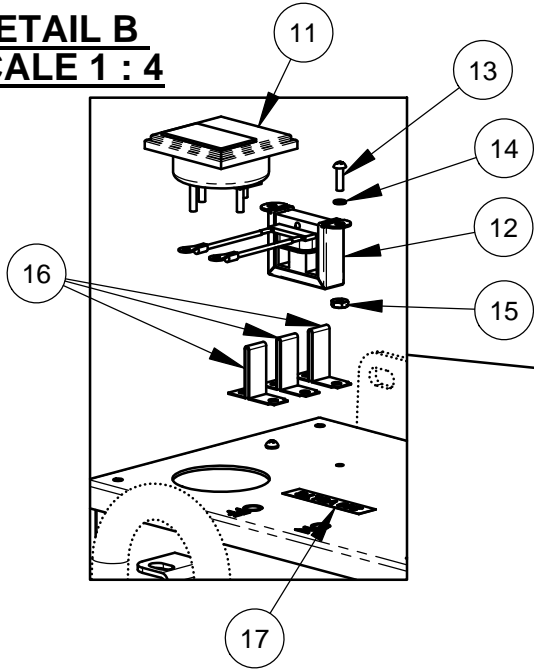

**DETAIL C**  
**SCALE 1 : 1.5**

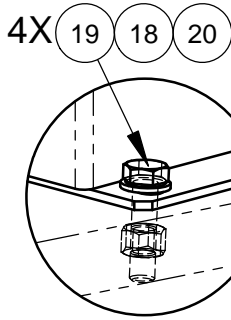

4X

- 7
- 3
- 3
- 6

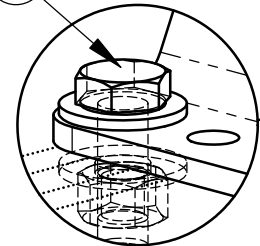

**DETAIL A**  
**SCALE 1 : 1.5**

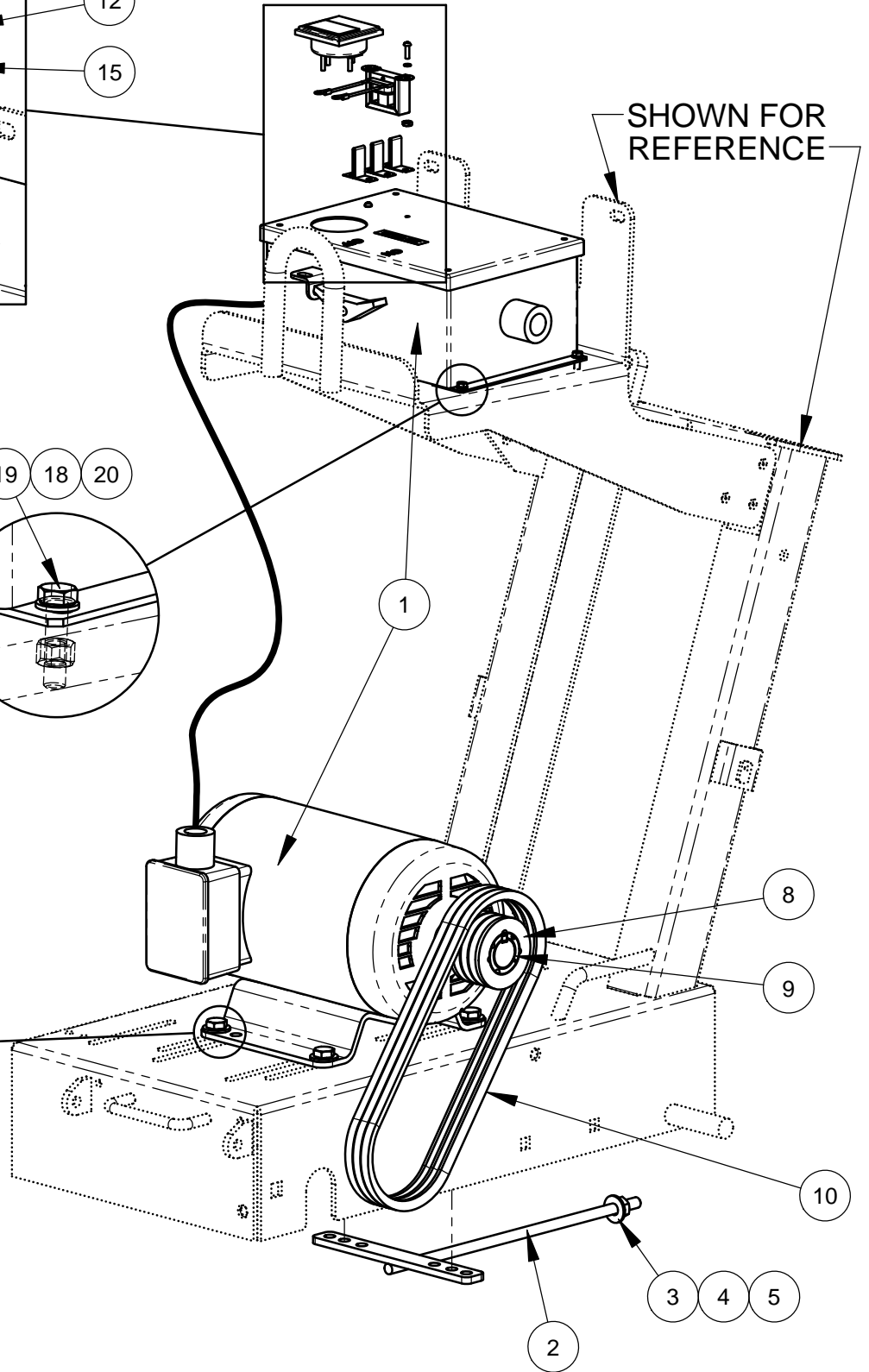

6043436 CC1300XL ELECTRIC MOTOR OPTION, 5HP, 230V, 3-PHASE

ITEM	PART NO.	QTY.	DESCRIPTION
1	6000032	1	5HP, 3 Ph, 230V Motor W/Starter Box
2	6040261	1	Belt Adjustment Weldment
3	2900473	9	Flat Washer, 3/8" USS
4	2900321	1	Lock Washer, M10 Split
5	2900325	1	Hex Nut, M10-1.5
6	2900223	4	Cap Screw, Hex Hd., M10-1.5 x 30mm
7	2900304	4	Lock Nut, M10-1.5 Nylon Insert
8	2500022	1	Sheave, 2.65 - 3 Groove
9	2500027	1	Taper Bushing, 1-1/8" W/ Setscrews & Key
10	2500380	3	V-Belt, 3VX300
11	2800253	1	Amp Meter w/ Bracket, 0-40 AC
12	2800085	1	AC Current Transformer
13	2900090	2	Machine Screw, Rd. Hd., #6-32 x 1/2"
14	2900092	2	Lock Washer, #6 Split
15	2900091	2	Hex Nut, #6-32
16	2800551	3	Heater, 12.1-12.7 Amp
17	1800810	1	Voltage Label, 230V
18	2900926	4	Flat Washer, M5
19	2900309	4	Cap Screw, Hex Hd., M5-0.8 x 20mm
20	2900301	4	Lock Nut, M5-0.8 Nylon Insert
21	6048181	1	Frame Weldment (Regular Cut)
22	6030318	1	Lift Bar Assembly

**6043437 CC1300XL ELECTRIC MOTOR OPTION, 5HP, 460V, 3-PHASE**

**DETAIL B**  
**SCALE 1 : 4**

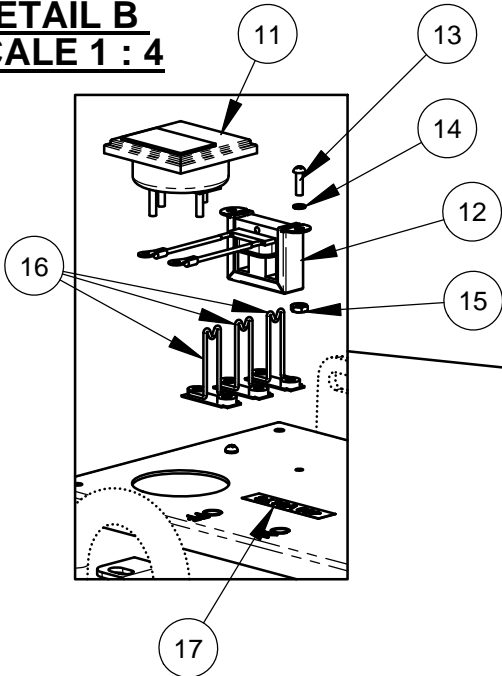

SHOWN FOR REFERENCE

**DETAIL C**  
**SCALE 1 : 1.5**

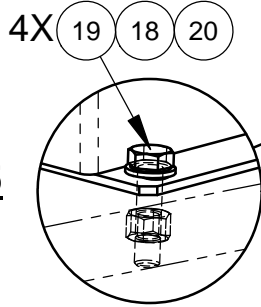

4X

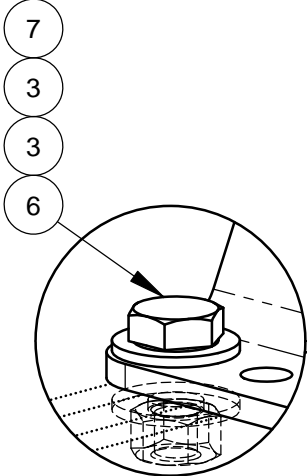

**DETAIL A**  
**SCALE 1 : 1.5**

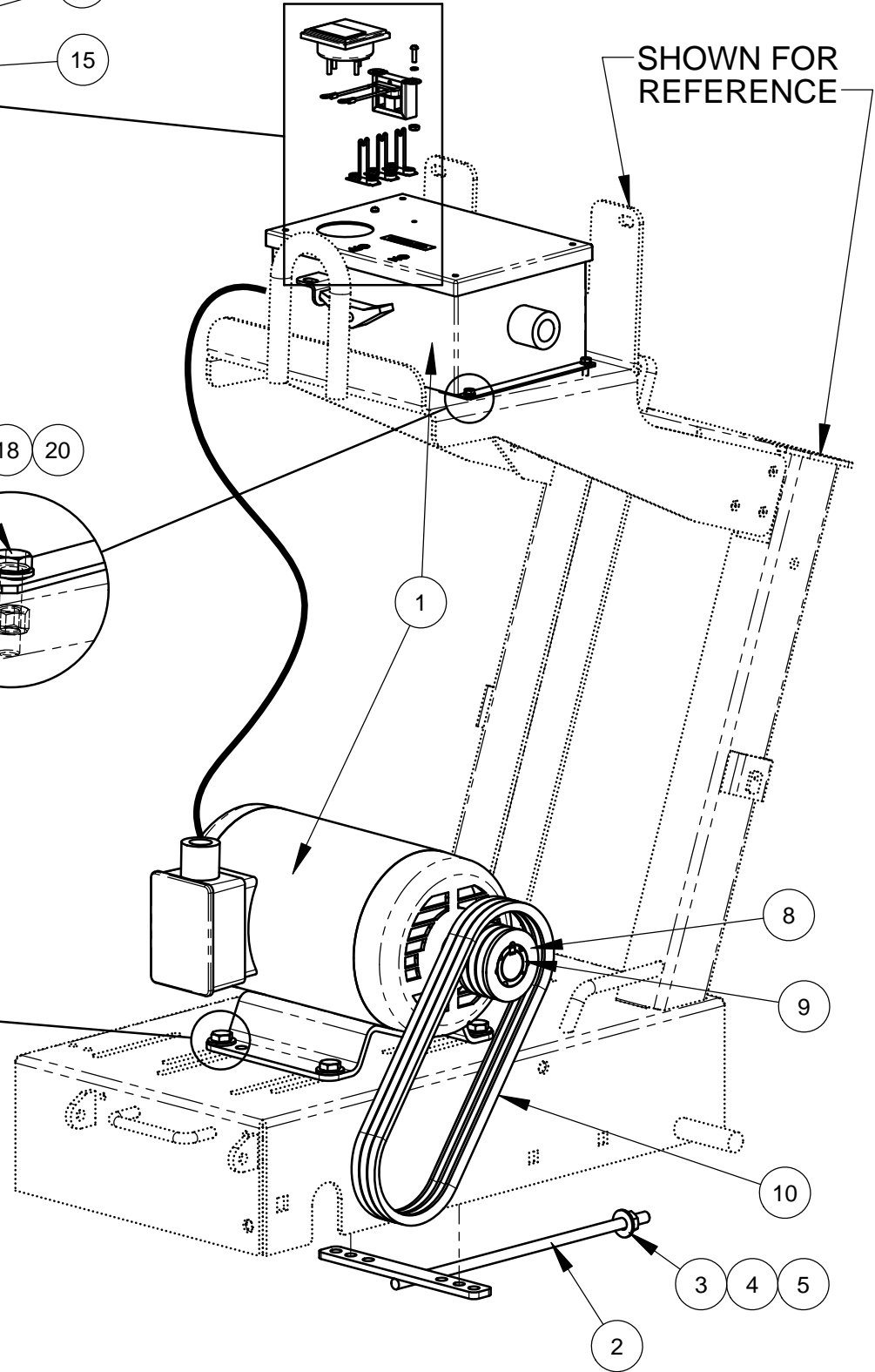

- 2
- 3
- 4
- 5

# 6043437 CC1300XL ELECTRIC MOTOR OPTION, 5HP, 460V, 3-PHASE

ITEM	PART NO.	QTY.	DESCRIPTION
1	6000033	1	5HP, 3Ph, 460V Motor W/ Starter Box
2	6040261	1	Belt Adjustment Weldment
3	2900473	9	Flat Washer, 3/8" USS
4	2900321	1	Lock Washer, M10 Split
5	2900325	1	Hex Nut, M10-1.5
6	2900223	4	Cap Screw, Hex Hd., M10-1.5 x 30mm
7	2900304	4	Lock Nut, M10-1.5 Nylon Insert
8	2500022	1	Sheave, 2.65 - 3 Groove
9	2500027	1	Taper Bushing, 1-1/8" W/ Setscrews & Key
10	2500380	3	V-Belt, 3VX300
11	2800253	1	Amp Meter w/ Bracket, 0-40 AC
12	2800085	1	AC Current Transformer
13	2900090	2	Machine Screw, Rd. Hd., #6-32 x 1/2"
14	2900092	2	Lock Washer, #6 Split
15	2900091	2	Hex Nut, #6-32
16	2800536	3	Heater, 6.3 - 6.9 Amp
17	1800811	1	Voltage Label, 460V
18	2900926	4	Flat Washer, M5
19	2900309	4	Cap Screw, Hex Hd., M5-0.8 x 20mm
20	2900301	4	Lock Nut, M5-0.8 Nylon Insert
21	6048181	1	Frame Weldment (Regular Cut)
22	6030318	1	Lift Bar Assembly

**6043400 CC1300 XL ELECTRIC MOTOR OPTION, 10HP, 230V, 3-PHASE**

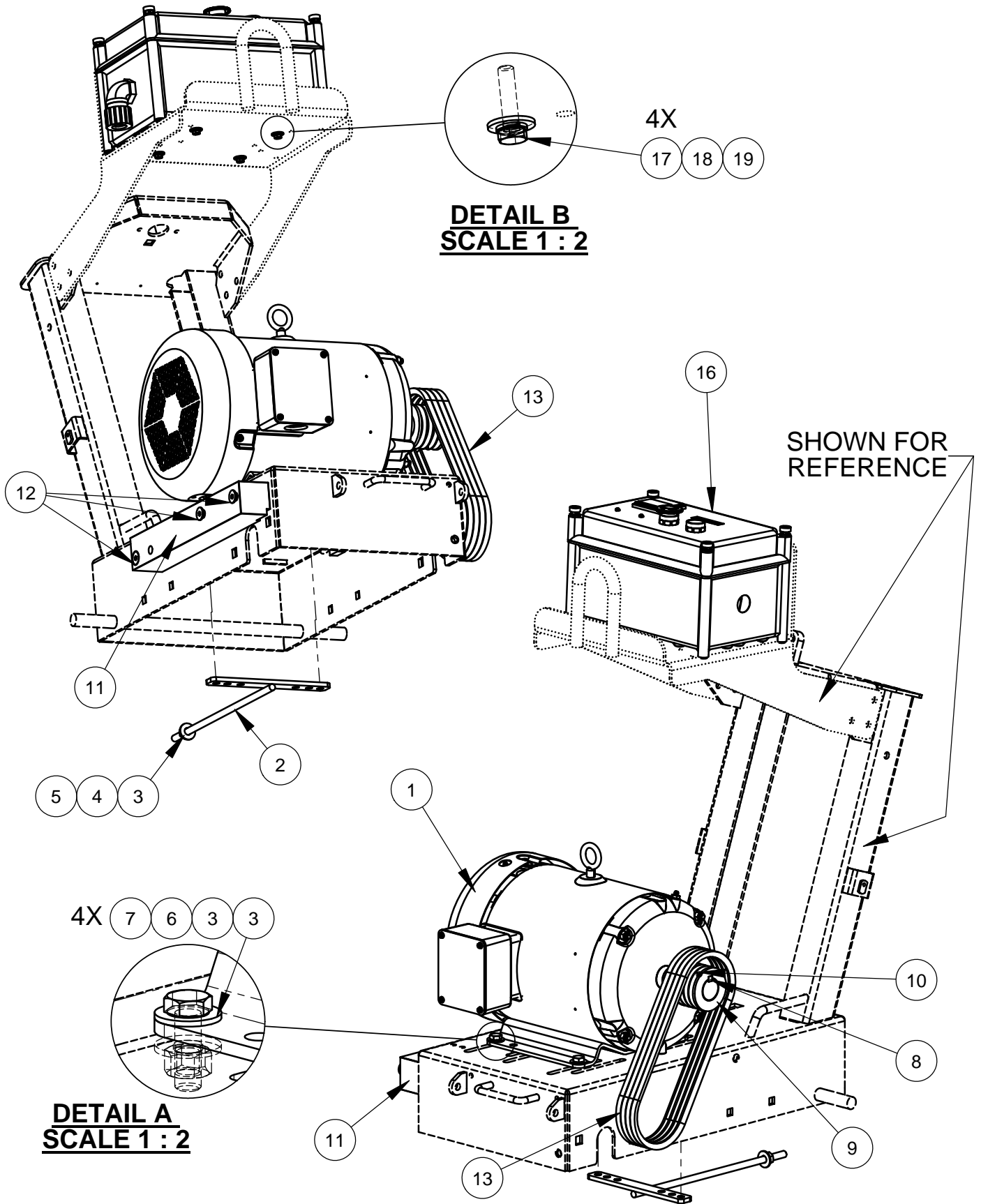



## 6043400 CC1300 XL ELECTRIC MOTOR OPTION, 10HP, 230V, 3-PHASE

ITEM NO.	PART NUMBER	QTY.	DESCRIPTION
1	2600187	1	Motor, 10hp 3 Phase Baldor
2	6040261	1	Belt Adjustment Weldment
3	2900473	9	Flat Washer, 3/8" USS
4	2900321	1	Lock Washer, M10 Split
5	2900325	1	Hex Nut, M10-1.5
6	2900223	4	Cap Screw, Hex Hd., M10-1.5 x 30mm
7	2900304	4	Lock Nut, M10-1.5 Nylon Insert
8	6048046	1	Key, 5/16" Sq. x 1-1/2"
9	6048897	1	Sheave, 2.65 - 4 Groove
10	2900036	1	Set Screw, Soc. Hd., 5/16-18 x 1/4"
11	6048319	1	Blade Guard Spacer
12	2900908	3	Cap Screw, Flat Hd., M10-1.5 x 80mm
13	2500380	4	V-Belt, 3VX300
14	6048181	1	Frame Weldment (Regular Cut)
15	6030318	1	Lift Bar Assembly
16	6004894	1	Starter Box Assembly, 3-Phase, 220-240V
17	2900311	4	Cap Screw, Hex Hd., M6-1.0 x 25mm
18	2900765	4	Lock Washer, M6 Split
19	2901359	4	Fender Washer, M6

**6043430 CC1300 XL ELECTRIC MOTOR OPTION, 10HP, 460V, 3-PHASE**

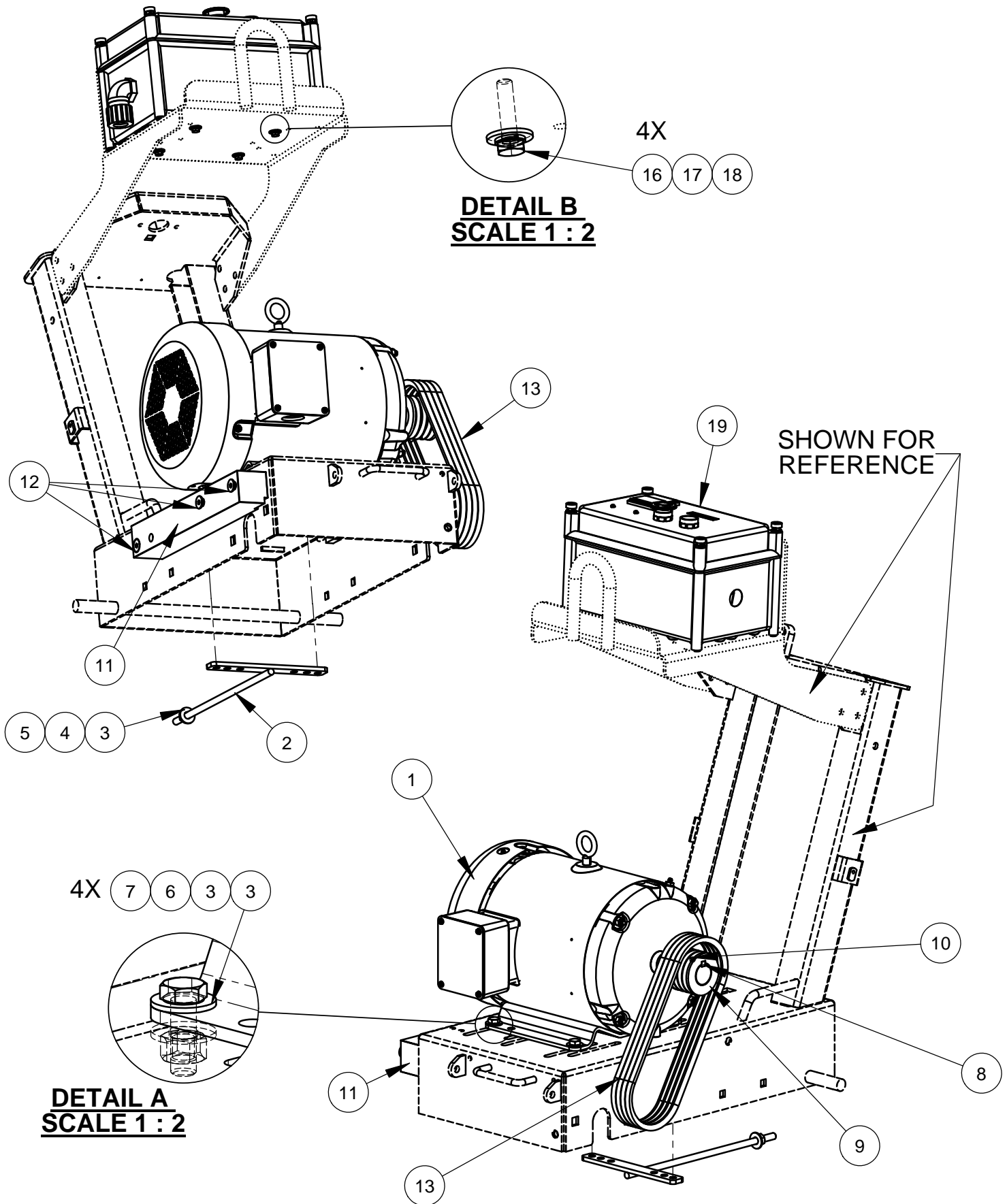

## 6043430 CC1300 XL ELECTRIC MOTOR OPTION, 10HP, 460V, 3-PHASE

ITEM NO.	PART NUMBER	QTY.	DESCRIPTION
1	2600187	1	Motor, 10hp 3 Phase Baldor
2	6040261	1	Belt Adjustment Weldment
3	2900473	9	Flat Washer, 3/8" USS
4	2900321	1	Lock Washer, M10 Split
5	2900325	1	Hex Nut, M10-1.5
6	2900223	4	Cap Screw, Hex Hd., M10-1.5 x 30mm
7	2900304	4	Lock Nut, M10-1.5 Nylon Insert
8	6048046	1	Key, 5/16" Sq. x 1-1/2"
9	6048897	1	Sheave, 2.65 - 4 Groove
10	2900036	1	Set Screw, Soc. Hd., 5/16-18 x 1/4"
11	6048319	1	Blade Guard Spacer
12	2900908	3	Cap Screw, Flat Hd., M10-1.5 x 80mm
13	2500380	4	V-Belt, 3VX300
14	6048181	1	Frame Weldment (Regular Cut)
15	6030318	1	Lift Bar Assembly
16	2900311	4	Cap Screw, Hex Hd., M6-1.0 x 25mm
17	2900765	4	Lock Washer, M6 Split
18	2901359	4	Fender Washer, M6
19	6004898	1	Starter Box Assembly, 3-Phase, 415-480V

**6043432 CC1300 XL ELECTRIC MOTOR OPTION, 10HP, 575V, 3-PHASE**

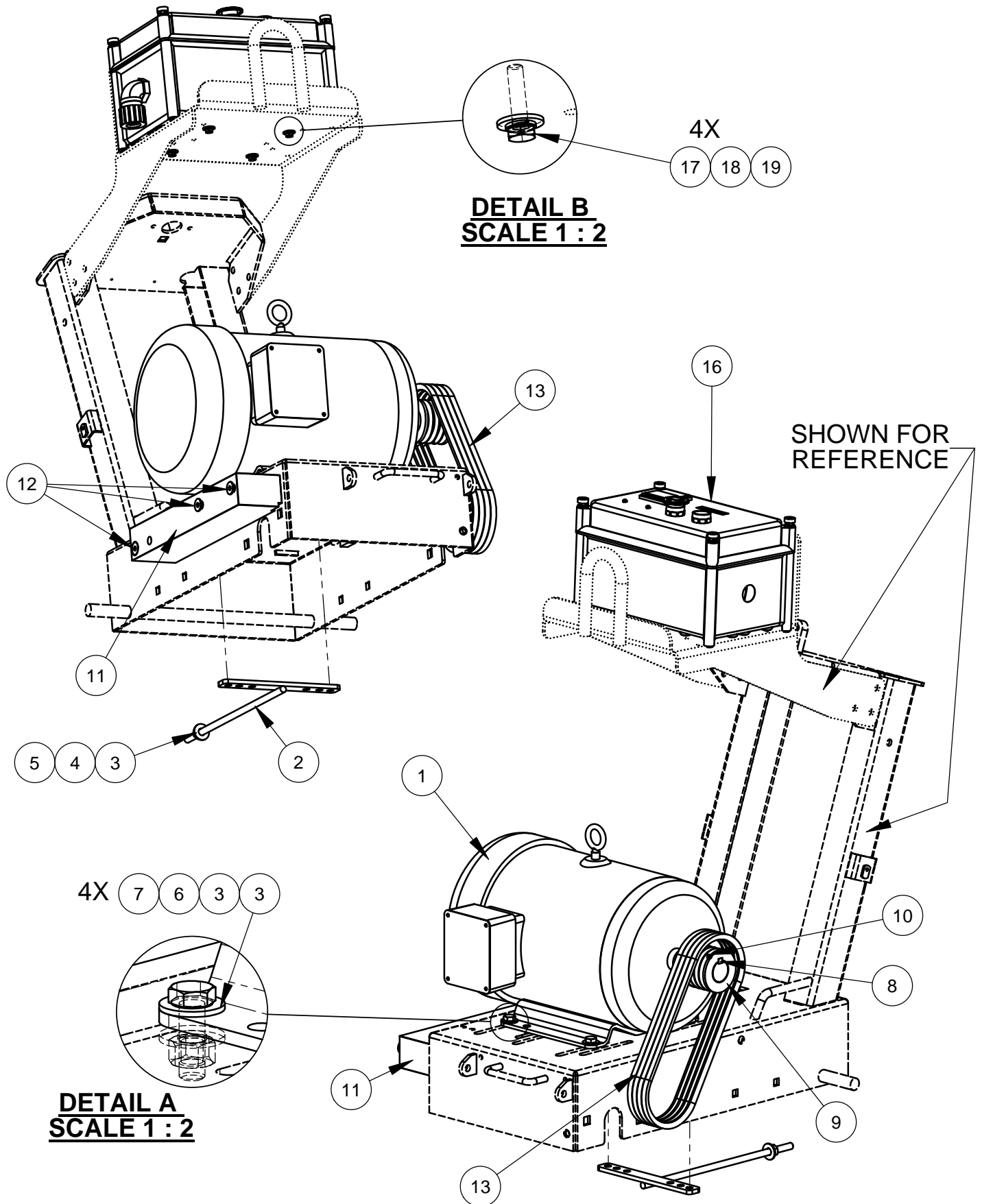

## 6043432 CC1300 XL ELECTRIC MOTOR OPTION, 10HP, 575V, 3-PHASE

ITEM NO.	PART NUMBER	QTY.	DESCRIPTION
1	2600703	1	Motor, 10 HP, 575V, 3 PH. Baldor
2	6040261	1	Belt Adjustment Weldment
3	2900473	9	Flat Washer, 3/8" USS
4	2900321	1	Lock Washer, M10 Split
5	2900325	1	Hex Nut, M10-1.5
6	2900223	4	Cap Screw, Hex Hd., M10-1.5 x 30mm
7	2900304	4	Lock Nut, M10-1.5 Nylon Insert
8	6048046	1	Key, 5/16" Sq. x 1-1/2"
9	6048897	1	Sheave, 2.65 - 4 Groove
10	2900036	1	Set Screw, Soc. Hd., 5/16-18 x 1/4"
11	6047308	1	Blade Guard Spacer, 3"
12	2901507	3	Cap Screw, Flat Hd., M10-1.5 x 100mm
13	2500380	4	V-Belt, 3VX300
14	6048181	1	Frame Weldment (Regular Cut)
15	6030318	1	Lift Bar Assembly
16	6004901	1	Starter Box Assembly, 3-Phase, 550-600V
17	2900311	4	Cap Screw, Hex Hd., M6-1.0 x 25mm
18	2900765	4	Lock Washer, M6 Split
19	2901359	4	Fender Washer, M6

**STARTER BOX ASSEMBLY, 3-PHASE, 220-240V**  
**#6004894**

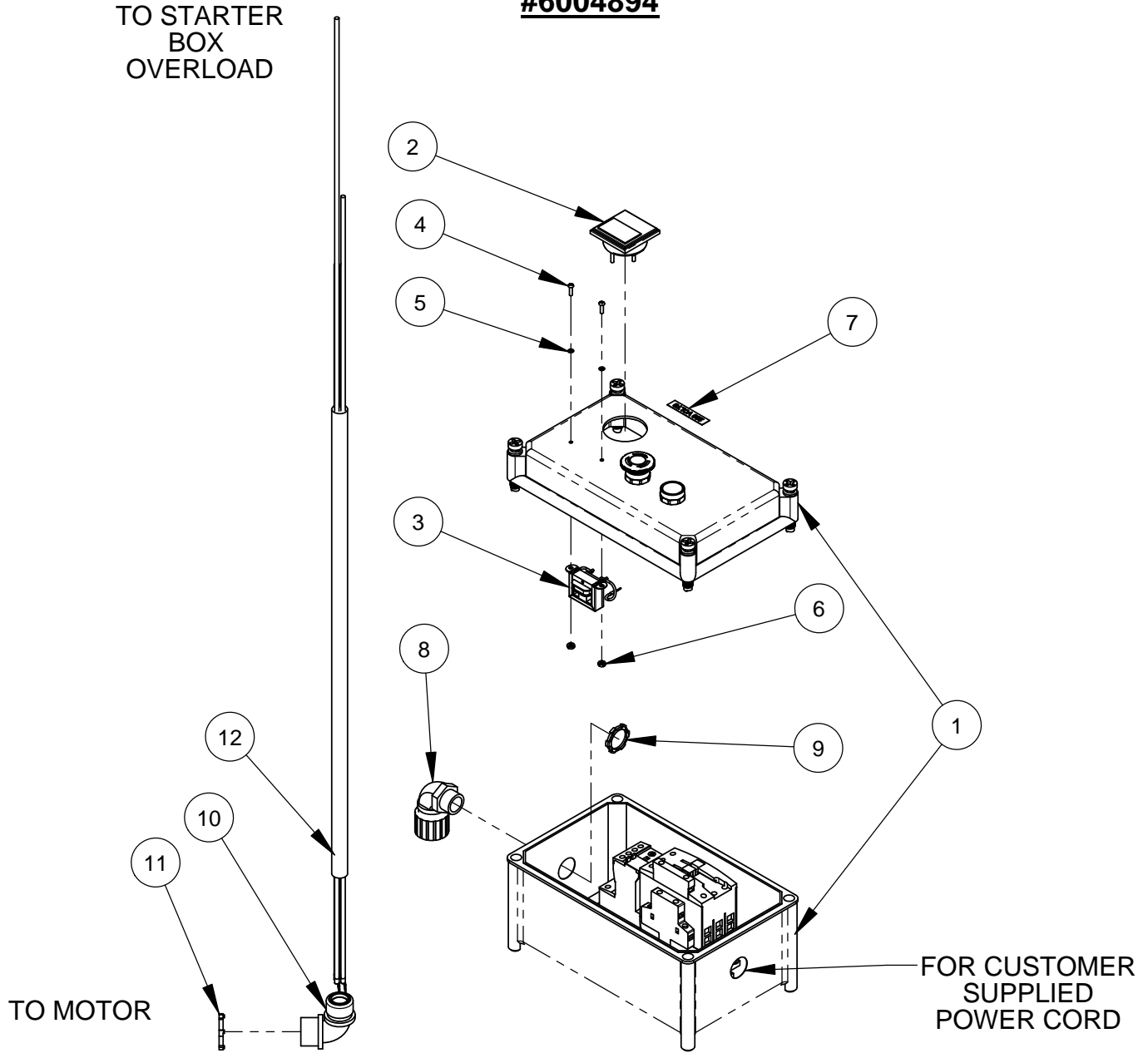

ITEM	PART NO.	QTY.	DESCRIPTION
1	2804008	1	Starter Box, 220-240V
2	2800253	1	Amp Meter w/ Bracket, 0-40 AC
3	2800085	1	AC Current Transformer
4	2900090	2	Machine Screw, Rd. Hd., #6-32 x 1/2"
5	2900092	2	Lock Washer, #6 Split
6	2900091	2	Hex Nut, #6-32
7	1800810	1	Voltage Label, 230V
8	2802052	1	Cord Connector, 3/4" Thd., .63-75" Cord, 90 Deg.
9	2801304	1	Lock Nut, 3/4"
10	2800695	1	Cord Grip, 5/8-3/4", 90 Deg.
11	2800193	1	Lock Nut, 1"
12	6040423	1	Cable Assy., 10 Ga., 4 Wire x 54"

**STARTER BOX ASSEMBLY, 3-PHASE, 415-480V**  
**#6004898**

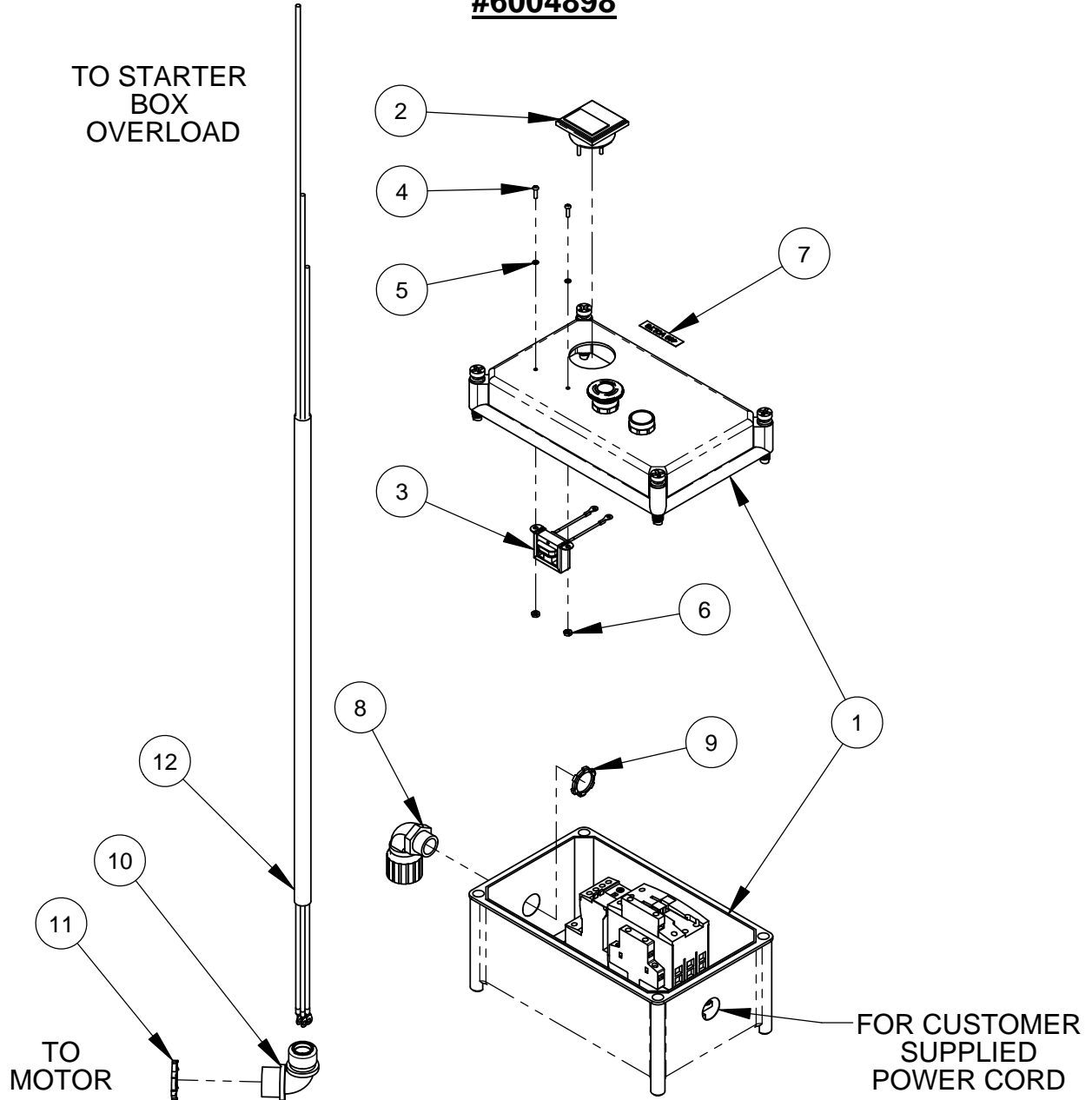

ITEM	PART NO.	QTY.	DESCRIPTION
1	2804007	1	Starter Box, 415-480V
2	2800252	1	Amp Meter, 0-20 AC
3	2800085	1	AC Current Transformer
4	2900090	2	Machine Screw, Rd. Hd., #6-32 x 1/2"
5	2900092	2	Lock Washer, #6 Split
6	2900091	2	Hex Nut, #6-32
7	1800811	1	Voltage Label, 460V
8	2802052	1	Cord Connector, 3/4" Thd., .63-75" Cord, 90 Deg.
9	2801304	1	Lock Nut, 3/4"
10	2800695	1	Cord Grip, 5/8-3/4", 90 Deg.
11	2800193	1	Lock Nut, 1"
12	6040423	1	Cable Assy., 10 Ga., 4 Wire x 54"

Intentionally Blank



**STARTERBOX ASSEMBLY, 3-PHASE, 550-600V**  
**#6004901**

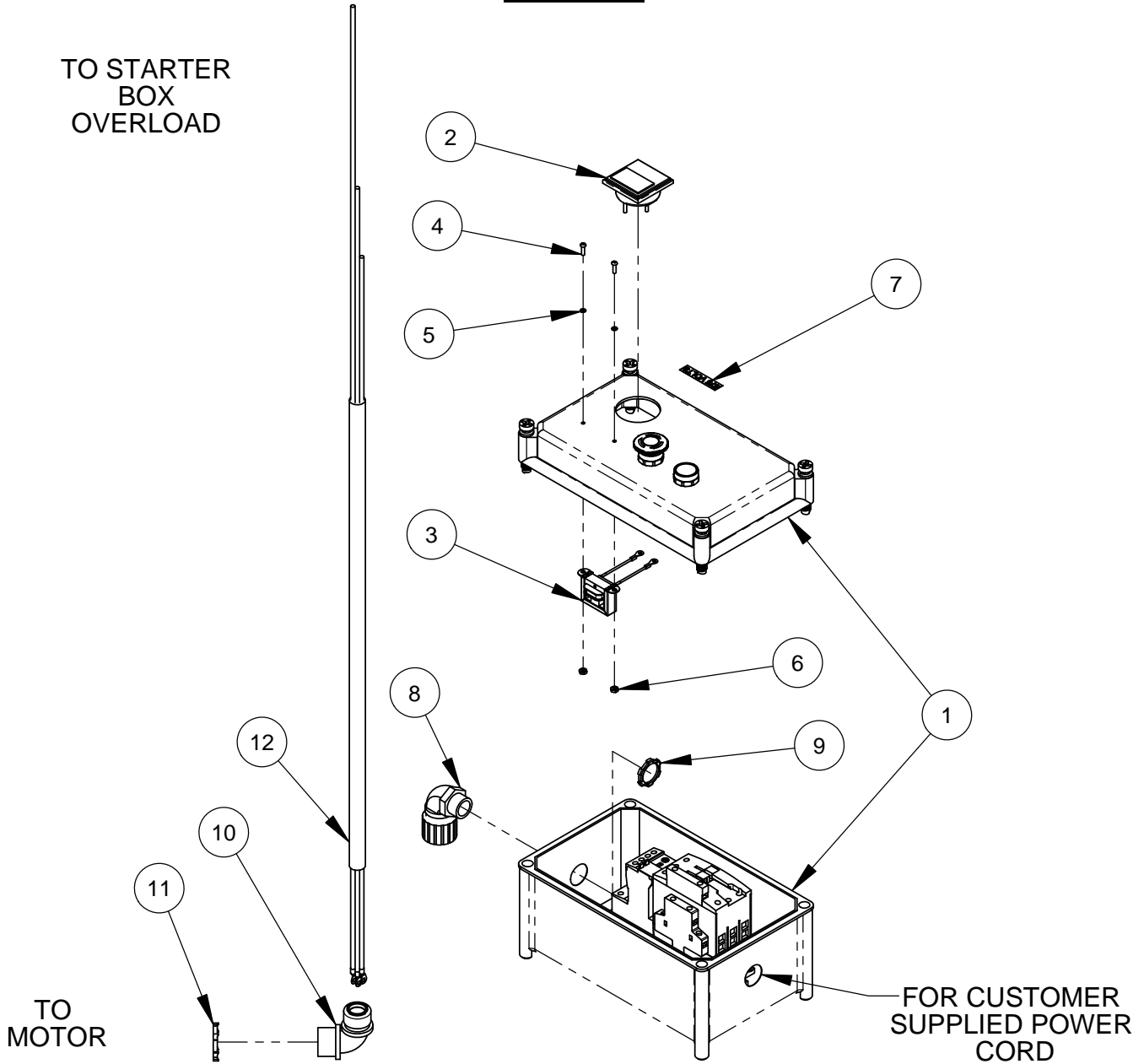

ITEM	PART NO.	QTY.	DESCRIPTION
1	2802061	1	Starter Box, 550-600V
2	2800252	1	Amp Meter, 0-20 AC
3	2800085	1	AC Current Transformer
4	2900090	2	Machine Screw, Rd. Hd., #6-32 x 1/2"
5	2900092	2	Lock Washer, #6 Split
6	2900091	2	Hex Nut, #6-32
7	1800812	1	Voltage Label, 575V
8	2802052	1	Cord Connector, 3/4" Thd., .63-75" Cord, 90 Deg.
9	2801304	1	Lock Nut, 3/4"
10	2800695	1	Cord Grip, 5/8-3/4", 90 Deg.
11	2800193	1	Lock Nut, 1"
12	6040423	1	Cable Assy., 10 Ga., 4 Wire x 54"

**STARTER BOX, 220-240 VOLT**  
**#2804008**

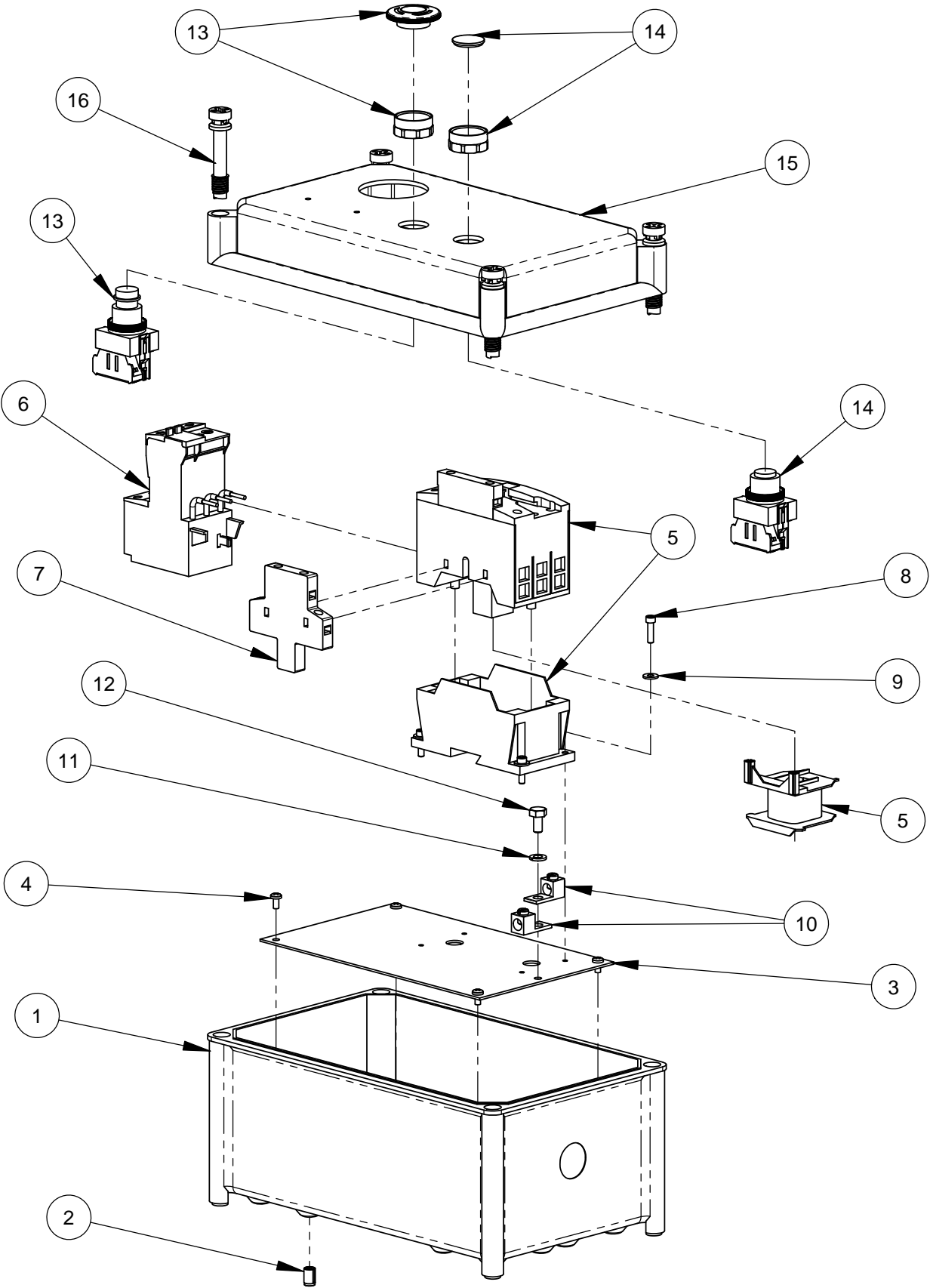

**STARTER BOX, 220-240 VOLT**  
**#2804008**

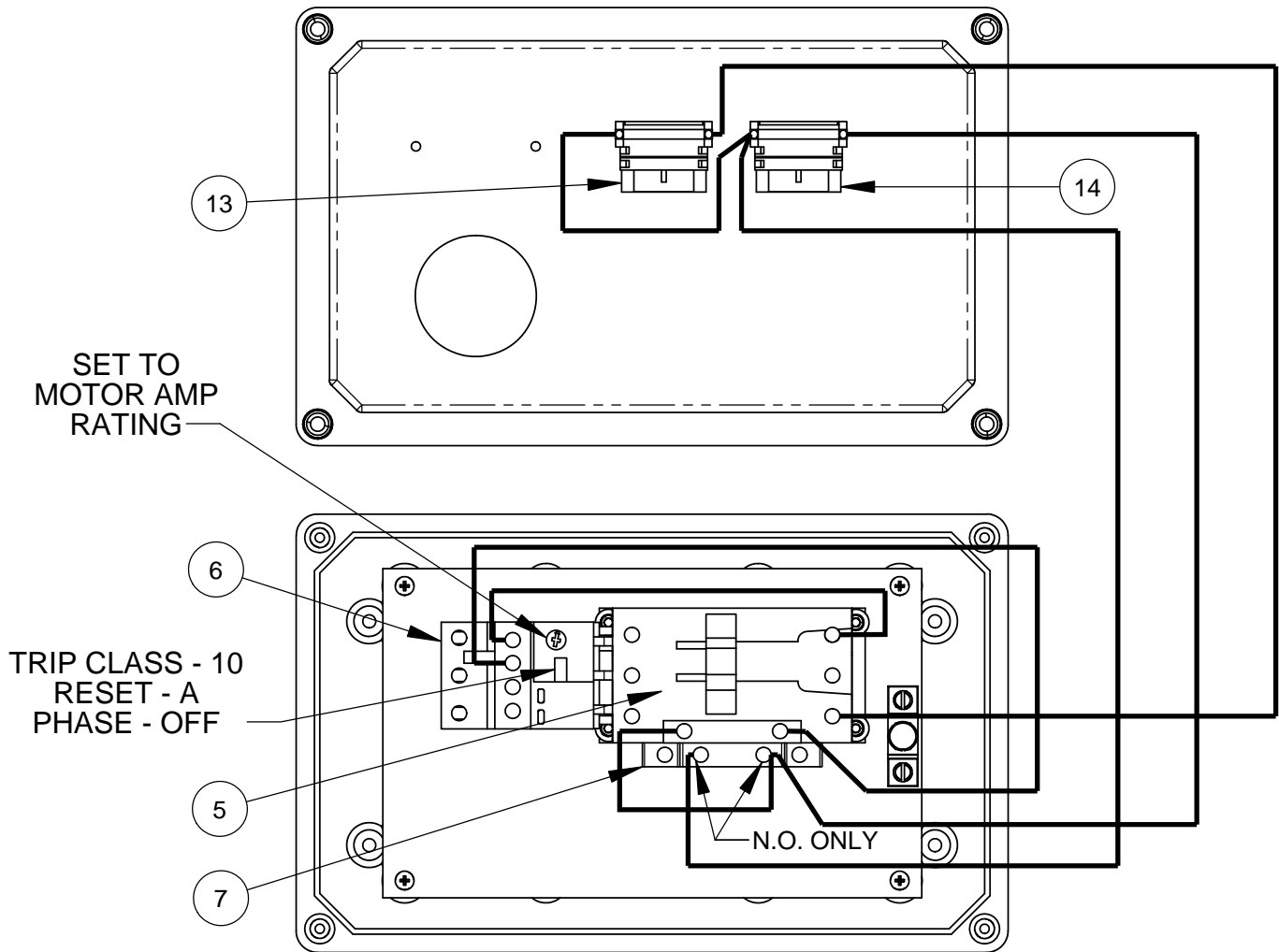

ITEM	PART NO.	QTY.	DESCRIPTION
1	6040300D	1	Starter Box Base
2	2901588	4	M6-1.0 Threaded Insert
3	6040598	1	Sub-plate
4	2900676	4	Machine Screw, Pan Hd., M4-0.7 x 8mm
5	2801704	1	Contactora, 220-240V (includes coil)
	2801265	1	Replacement Coil, 220-240V
6	2801699	1	Overload Relay, 9-45 AMP
7	2801676	1	Auxiliary Contacts, 1NO-NC
8	2901827	4	Cap Screw, Soc. Hd., #8-32 x 5/8"
9	2901437	4	Flat Washer, #10
10	2800315	2	Grounding Lug
11	2900024	1	Lock Washer, 1/4" Split
12	2901891	1	Cap Screw, Hex Hd., 1/4-28 x 1/2"
13	2801636	1	E-Stop Switch, 600V
14	2801639	1	Pushbutton, N.O., 600V
15	6048293	1	Starter Box Cover
16	2701414	4	Fastener, Electrical Box Top

**STARTER BOX, 415-480 VOLT**  
**#2804007**

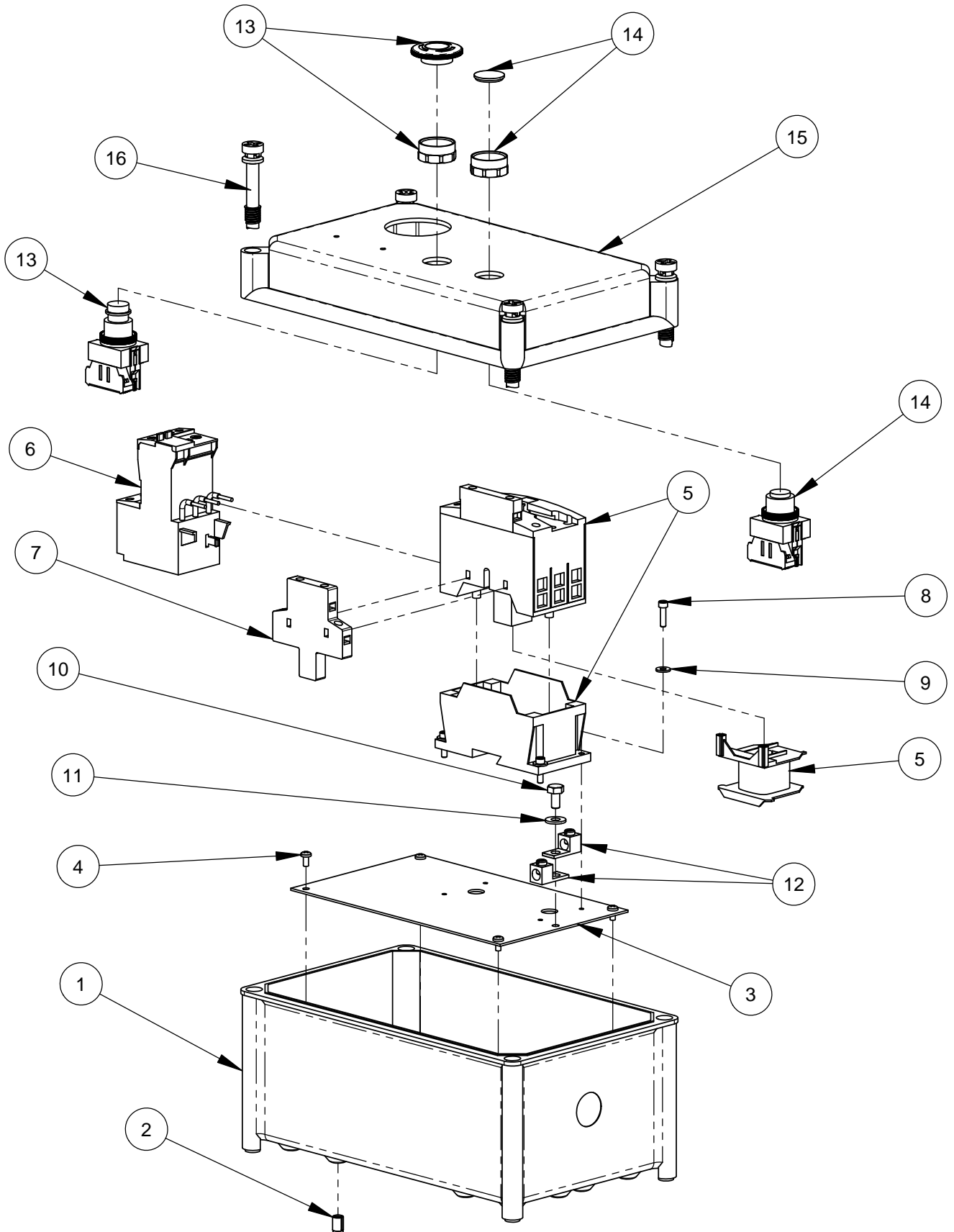

**STARTER BOX, 415-480 VOLT**  
**#2804007**

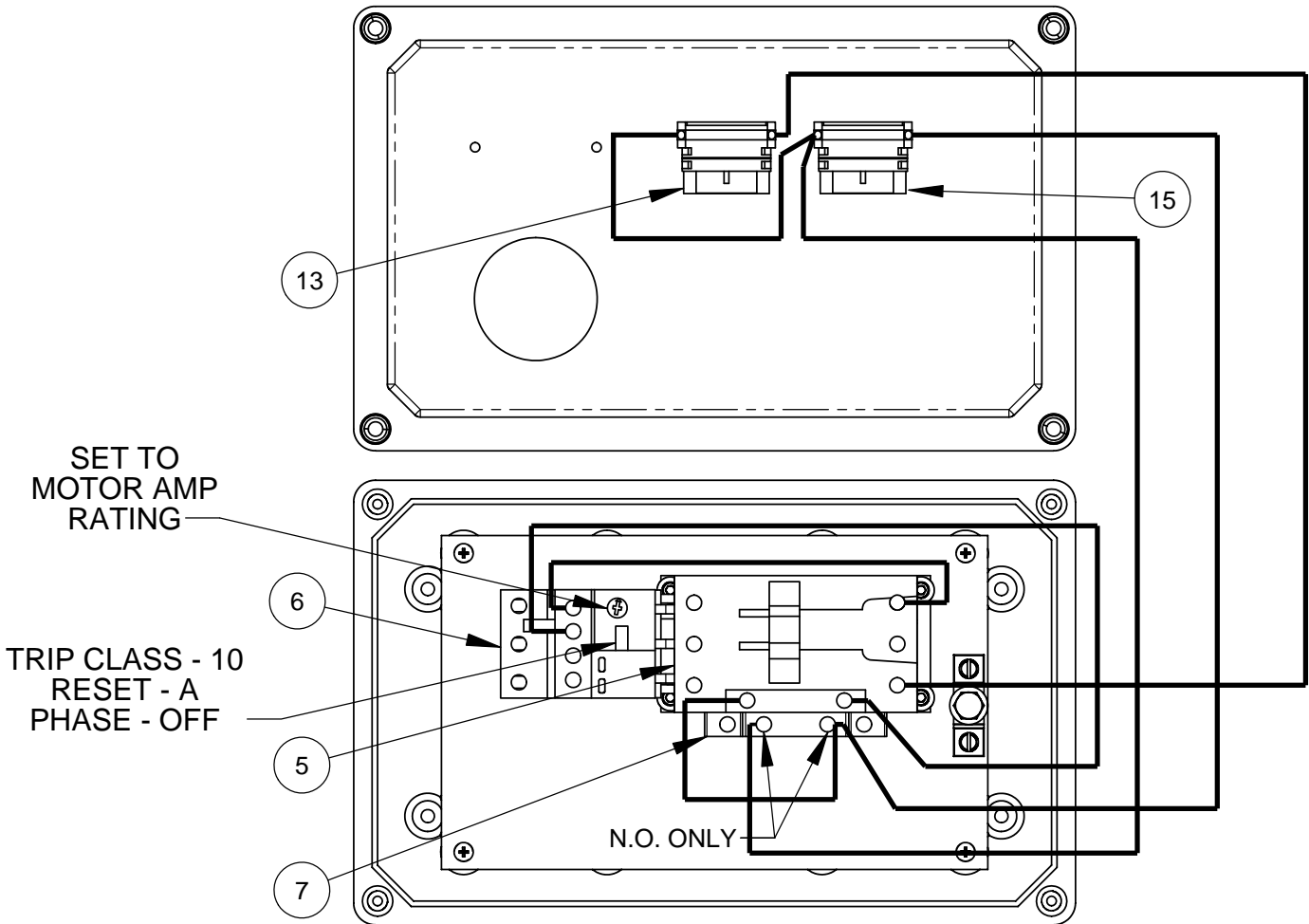

ITEM	PART NO.	QTY.	DESCRIPTION
1	6040300D	1	Starter Box Base
2	2901588	4	M6-1.0 Threaded Insert
3	6040598	1	Sub-plate
4	2900676	4	Machine Screw, Pan Hd., M4-0.7 x 8mm
5	2801707	1	Contactor, 415-480V (Includes Coil)
	2801266	1	Replacement Coil, 415-480V
6	2801699	1	Overload Relay, 9-45 AMP
7	2801676	1	Auxiliary Contacts, 1NO-NC
8	2901827	4	Cap Screw, Soc. Hd., #8-32 x 5/8"
9	2901437	4	Flat Washer, #10
10	2901891	1	Cap Screw, Hex Hd., 1/4-28 x 1/2"
11	2900009	1	Flat Washer, 1/4" SAE
12	2800315	2	Grounding Lug
13	2801636	1	E-Stop Switch, 600V
14	2801639	1	Pushbutton, N.O., 600V
15	6048293	1	Starter Box Cover
16	2701414	4	Fastener, Electrical Box Top

**STARTER BOX, 550-600 VOLT**  
**#2802061**

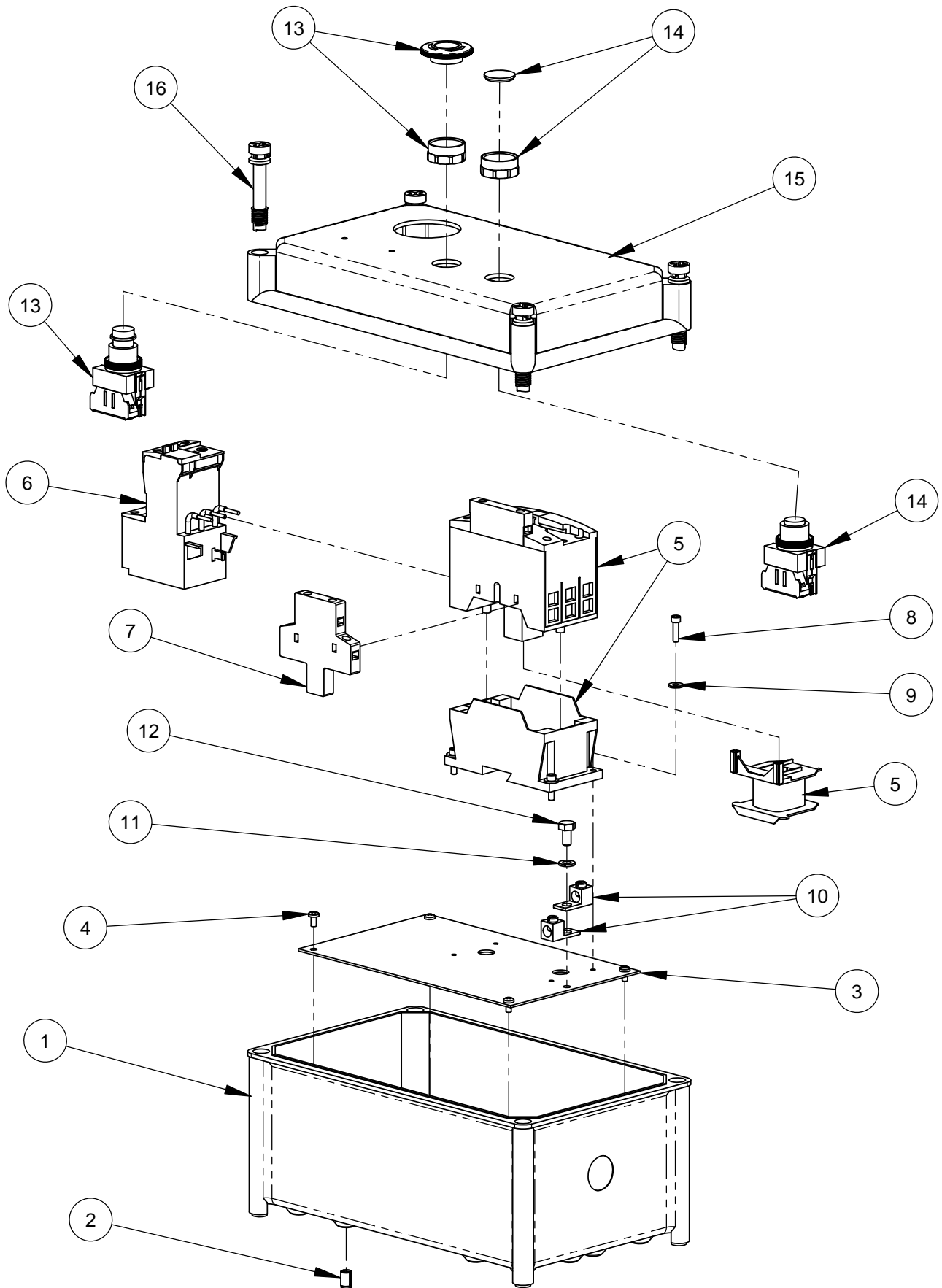

**STARTER BOX, 550-600 VOLT**  
**#2802061**

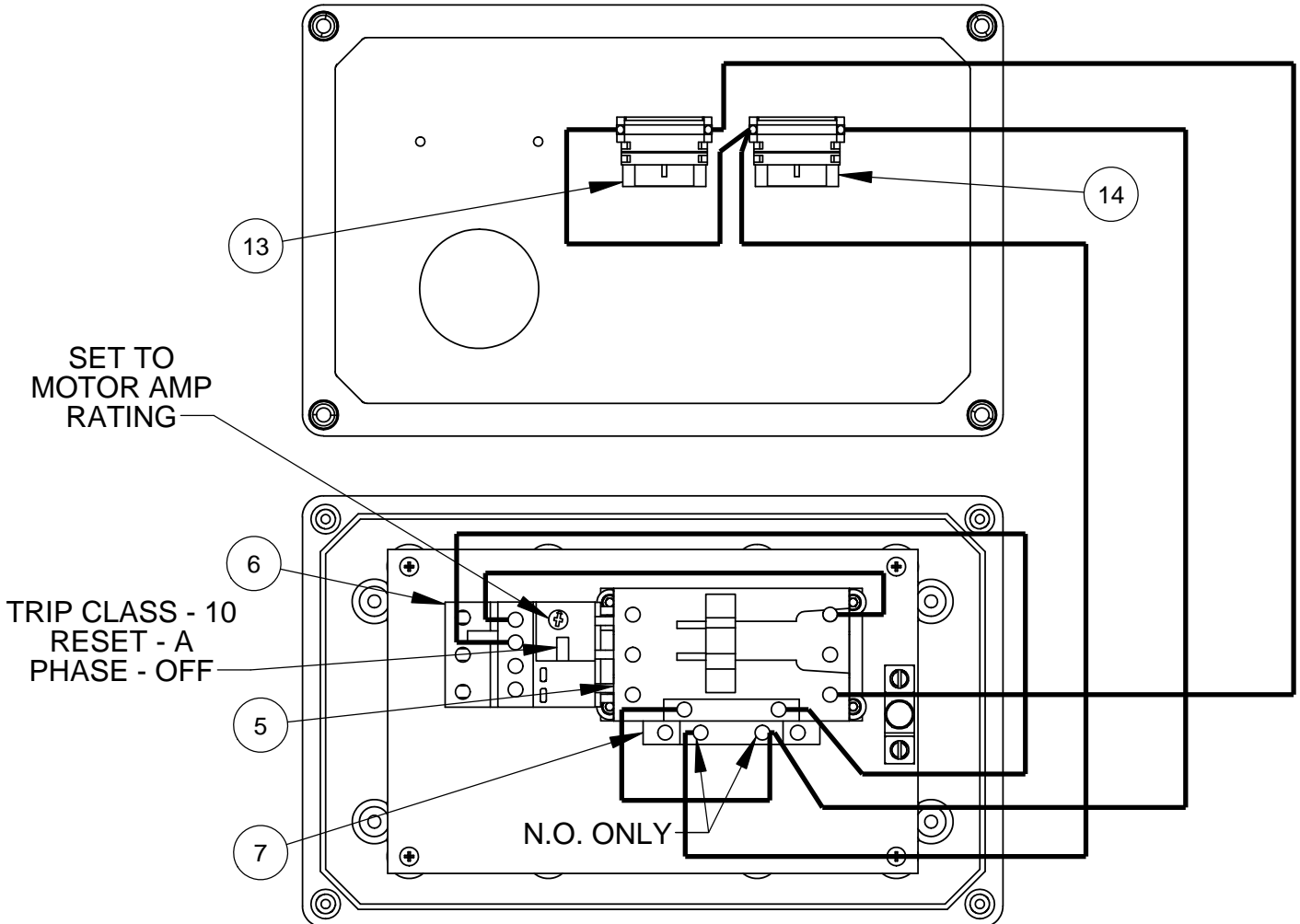

ITEM	PART NO.	QTY.	DESCRIPTION
1	6040300D	1	Starter Box Base
2	2901588	4	M6-1.0 Threaded Insert
3	6040598	1	Sub-plate
4	2900676	4	Machine Screw, Pan Hd., M4-0.7 x 8mm
5	2801709	1	Contactor, 550-600V (includes coil)
	2801267	1	Replacement Coil, 550-600V
6	2801699	1	Overload Relay, 9-45 AMP
7	2801676	1	Auxiliary Contacts, 1NO-NC
8	2901827	4	Cap Screw, Soc. Hd., #8-32 x 5/8"
9	2901437	4	Flat Washer, #10
10	2800315	2	Grounding Lug
11	2900024	1	Lock Washer, 1/4" Split
12	2901891	1	Cap Screw, Hex Hd., 1/4-28 x 1/2"
13	2801636	1	E-Stop Switch, 600V
14	2801639	1	Pushbutton, N.O., 600V
15	6048293	1	Starter Box Cover
16	2701414	4	Fastener, Electrical Box Top

## Blade Shaft Assembly, #6041041

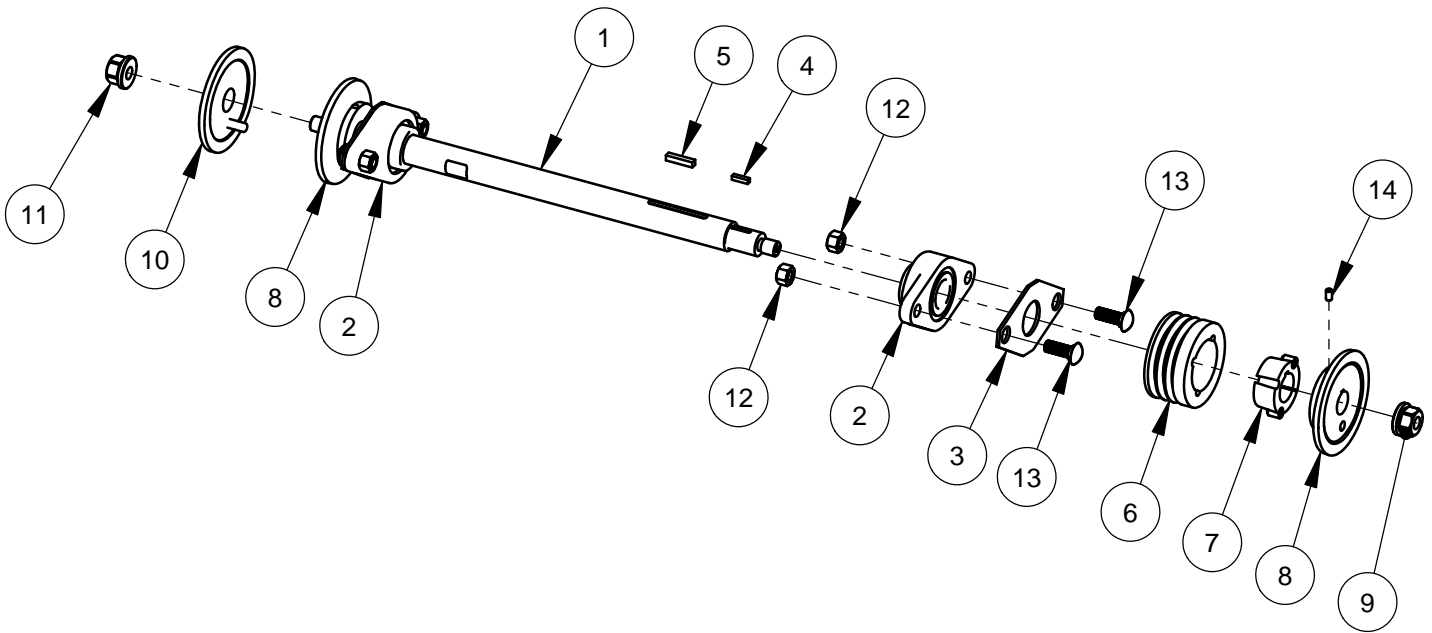
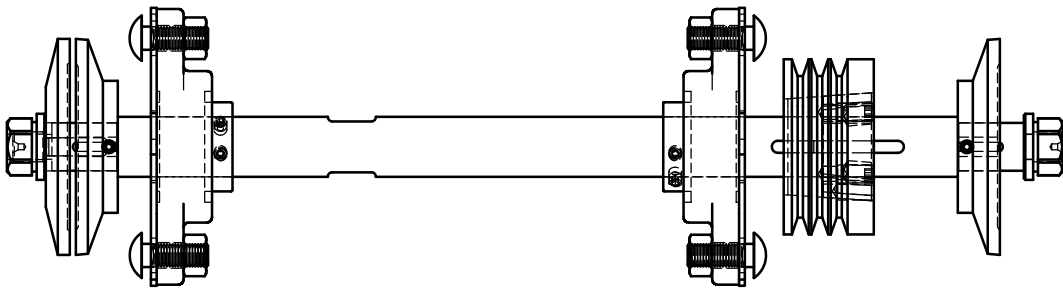

ITEM	PART NO.	QTY.	DESCRIPTION
1	6048866	1	Blade Shaft
2	2500576	2	Flange Block Bearing, 1-1/4"
3	6048037	2	Bearing Spacer
4	6048018	2	Key, 3/16" Sq. x 3/4"
5	6010169	1	Key, 1/4" Sq. x 1-1/4"
6	2500025	1	Sheave, 3.65-3 Groove
7	2500337	1	Taper Bushing, 1-1/4"
8	6048008	2	Inner Flange 4-1/2"
9	2900065	1	Flange Nut, 5/8-11 R.H.
10	6048009	1	Outer Flange, 4-1/2" w/ Pin
11	2900066	1	Flange Nut, 5/8-11, L. Hand
12	2900327	4	Lock Nut, M12-1.75 Nylon Insert
13	2900322	4	Carriage Bolt, M12-1.75 x 35
14	2900076	2	Set Screw, Soc. Hd., 1/4-20 x 1/2"



**6040500 BLADE SHAFT ASSEMBLY, 10 HP, 230/460 VOLT**

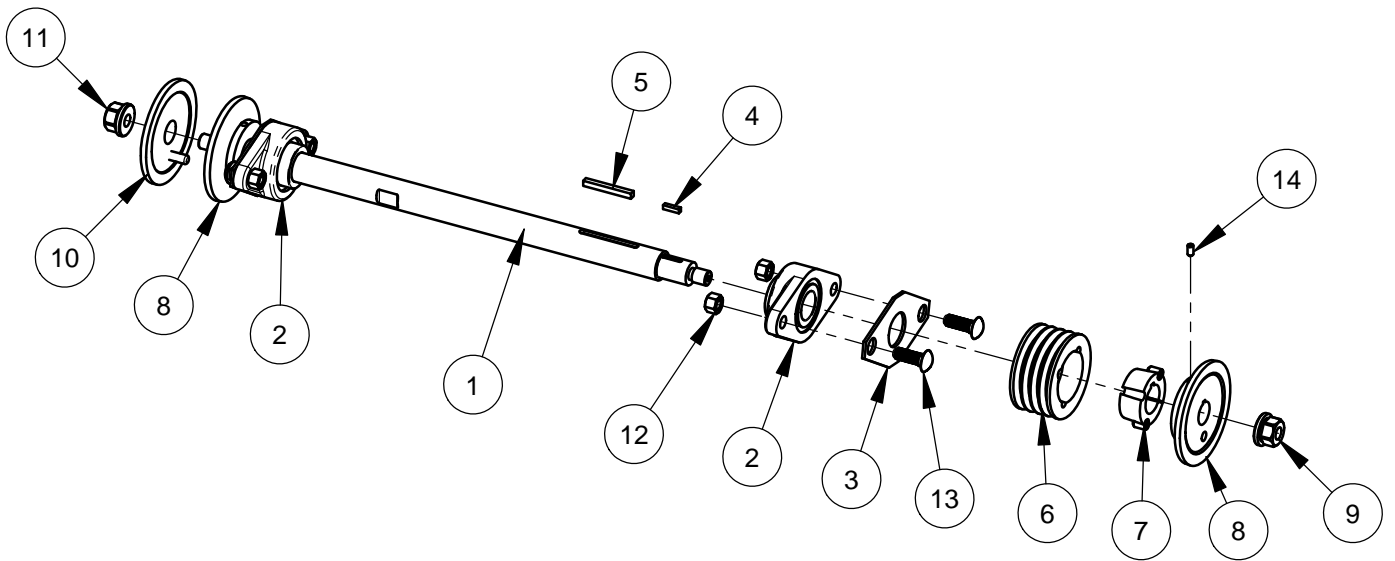
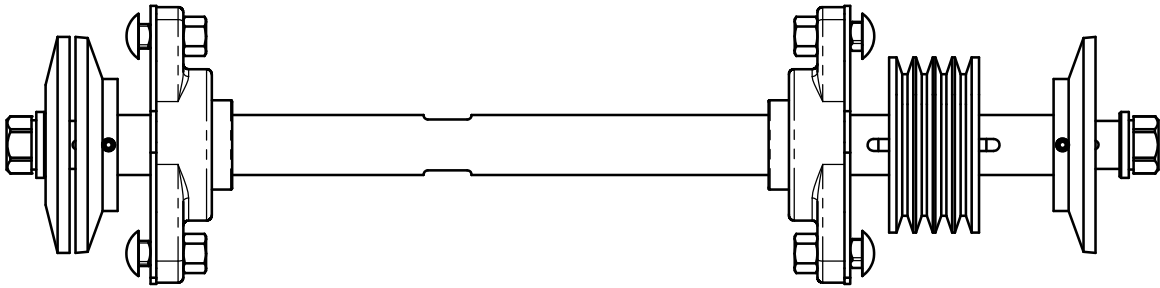

ALSO FIT 575 VOLT MODELS  
PRIOR TO MARCH 2011.

ITEM	PART NO.	QTY.	DESCRIPTION
1	6048865	1	Blade Shaft
2	2500576	2	Flange Block Bearing, 1-1/4"
3	6048037	2	Bearing Spacer
4	6048018	2	Key, 3/16" Sq. x 3/4"
5	6048134	1	Key, 1/4" Sq. x 2-1/4"
6	2500621	1	Sheave, 3V-3.65-4 Groove (1610)
7	2500337	1	Taper Bushing, 1-1/4" w/ Set Screws
8	6048008	2	Inner Flange 4-1/2"
9	2900065	1	Flange Nut, 5/8-11 R.H.
10	6048009	1	Outer Flange, 4-1/2" w/ Pin
11	2900066	1	Flange Nut, 5/8-11 L.H.
12	2900327	4	Lock Nut, M12 Nylon
13	2900322	4	Carriage Bolt, M12-1.75 x 35
14	2900076	2	Set Screw, Soc. Hd., 1/4-20 x 1/2"

**6040528 BLADE SHAFT ASSEMBLY, 575V UNITS.**

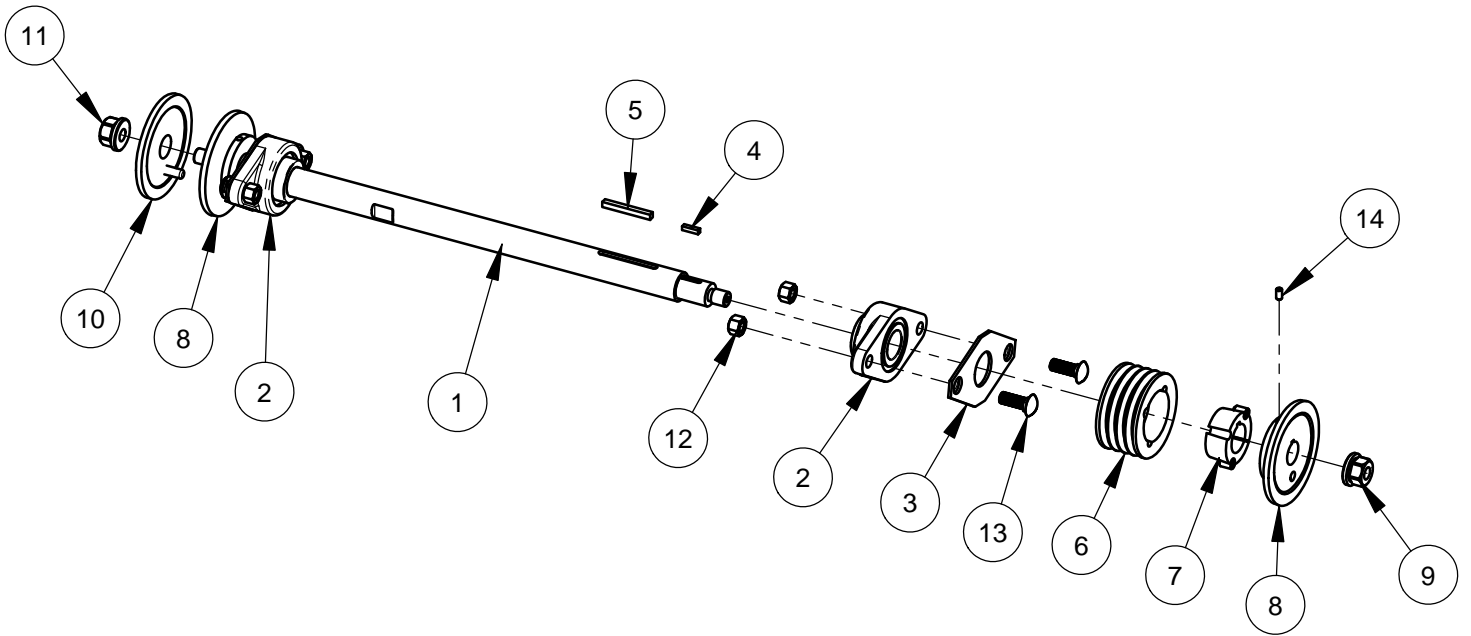
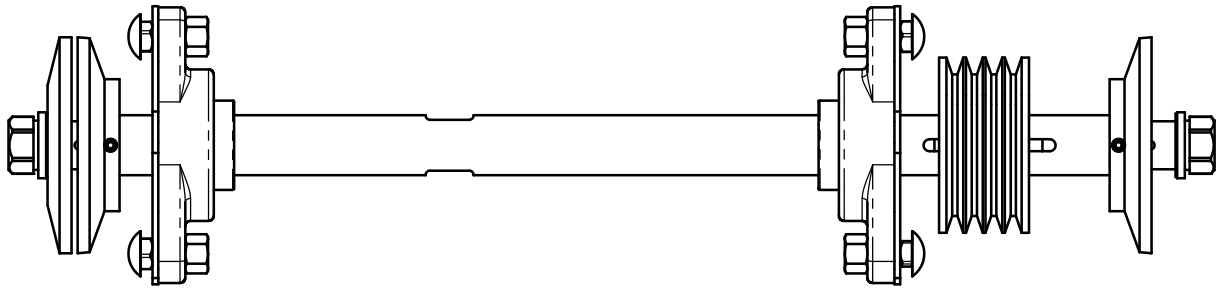

ITEM	PART NO.	QTY.	DESCRIPTION
1	6048880	1	Blade Shaft
2	2500576	2	Flange Block Bearing, 1-1/4"
3	6048037	2	Bearing Spacer
4	6048018	2	Key, 3/16" Sq. x 3/4"
5	6048134	1	Key, 1/4" Sq. x 2-1/4"
6	2500621	1	Sheave, 3V-3.65-4 Groove (1610)
7	2500337	1	Taper Bushing, 1-1/4" w/ Set Screws
8	6048008	2	Inner Flange 4-1/2"
9	2900065	1	Flange Nut, 5/8-11 R.H.
10	6048009	1	Outer Flange, 4-1/2" w/ Pin
11	2900066	1	Flange Nut, 5/8-11 L.H.
12	2900327	4	Lock Nut, M12 Nylon
13	2900322	4	Carriage Bolt, M12-1.75 x 35
14	2900076	2	Set Screw, Soc. Hd., 1/4-20 x 1/2"

**14" Blade Guard Assembly**  
**#6048912**

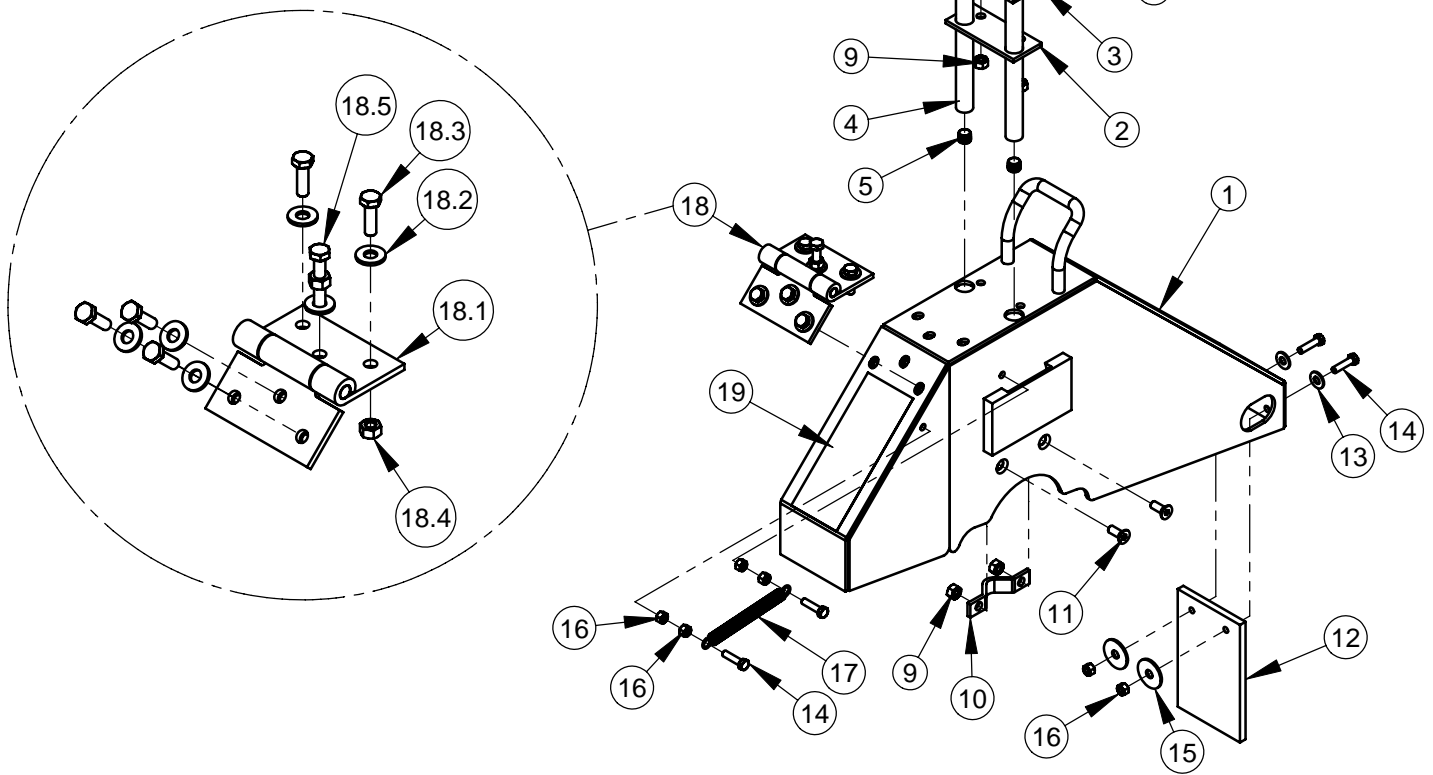

ITEM	PART NO.	QTY.	DESCRIPTION
1	6048911	1	14" Blade Guard
2	2500829	1	Water Manifold Gasket
3	6048123	1	Water Manifold
4	6048283	2	Water Tube for 14" Guard
5	3200001	3	Plug, 1/8" NPT
6	3200002	1	Fitting, 3/8" M. Pipe to 3/4" M. Garden
7	2900009	2	Flat Washer, 1/4" SAE
8	2900244	2	Cap Screw, Hex Hd., M6 x 45mm
9	2900302	6	Lock Nut, M6 Nylon
10	6048155	2	Water Tube Clamp
11	2900308	4	Cap Screw, Flat Hd. Soc., M6 x 16mm
12	6048039	1	Splash Flap
13	2900016	2	Flat Washer, #10 USS
14	2900309	4	Cap Screw, Hex Hd., M5 x 20mm
15	2900083	2	Fender Washer, 1/4" I.D. x 1-1/4" O.D.
16	2900301	6	Lock Nut, M5 Nylon
17	2500066	1	Spring, 3/8 X .055 X 3"
18	6048026	1	Hinge Assy., Metric Fasteners
18.1	2500270	1	Blade Guard Hinge
18.2	2900009	6	Flat Washer, 1/4" SAE
18.3	2900310	5	Cap Screw, Hex Hd., M6 x 20mm
18.4	2900302	7	Lock Nut, M6 Nylon
18.5	2900312	1	Cap Screw, Hex Hd., M6 x 35mm
19	1800001	1	Warning Label

# 18" Blade Guard Assembly 6048910

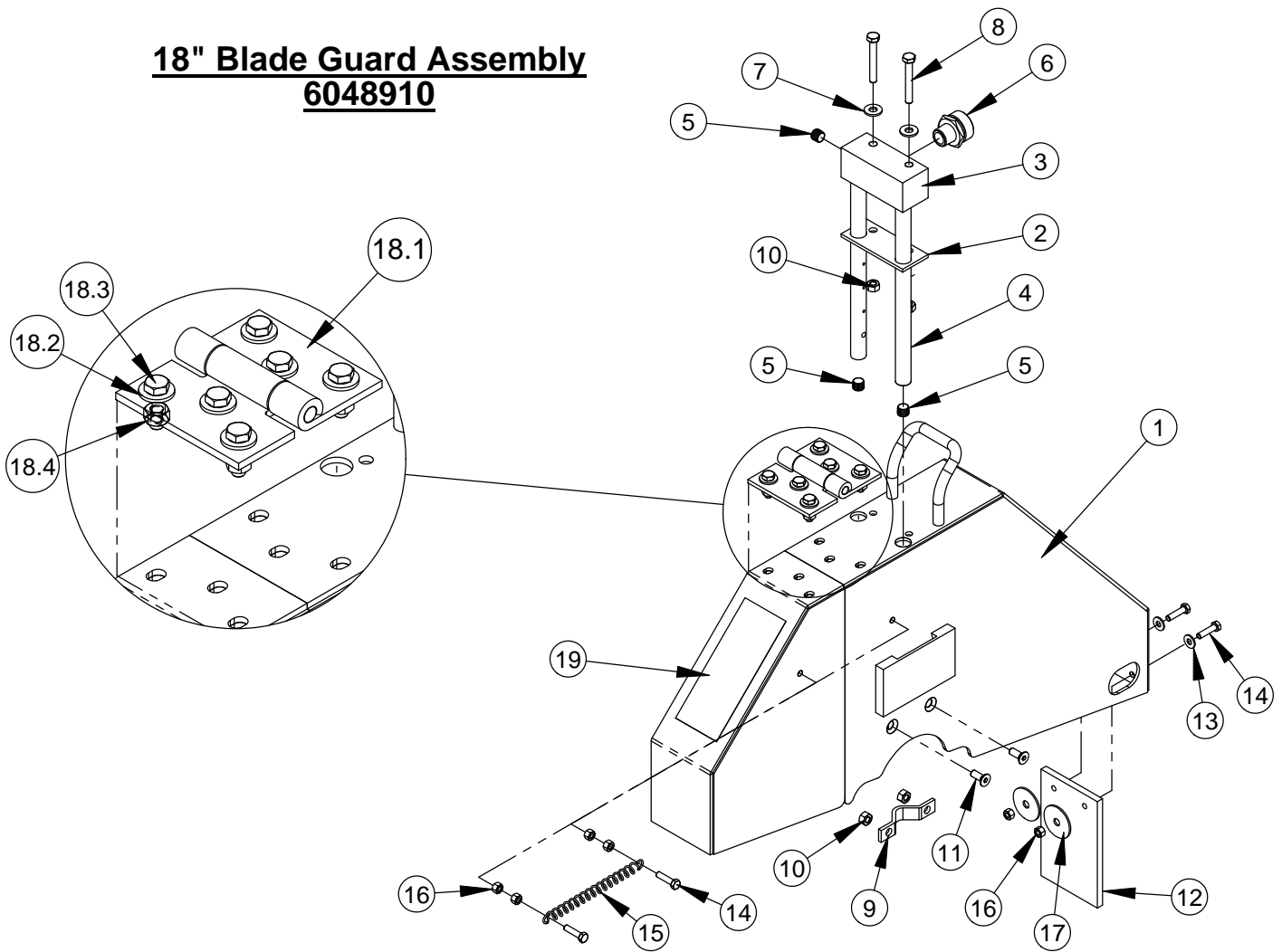

ITEM	PART NO.	QTY.	DESCRIPTION
1	6048909	1	18" Blade Guard Assembly
2	2500829	1	Water Manifold Gasket
3	6048123	1	Water Manifold
4	6048243	2	Water Tube for 18" Guard
5	3200001	3	Plug, 1/8" NPT
6	3200002	1	Fitting, 3/8" M. Pipe to 3/4" M. Garden
7	2900009	2	Flat Washer, 1/4" SAE
8	2900244	2	Cap Screw, Hex Hd., M6-1.0 x 45mm
9	6048155	2	Water Tube Clamp
10	2900302	6	Lock Nut, M6 Nylon
11	2900308	4	Cap Screw, Flat Hd., M6-1.0 x 16mm
12	6048039	1	Splash Flap
13	2900016	2	Flat Washer, #10 USS
14	2900309	4	Cap Screw, Hex Hd., M5-0.8 x 20mm
15	2500067	1	Spring, 3/8" x 4"
16	2900301	6	Lock Nut, M5-0.8 Nylon Insert
17	2900083	2	Fender Washer, 1/4" x 1-1/4"
18	6048027	1	Hinge Assy., Metric Fasteners
18.1	2500270	1	Blade Guard Hinge
18.2	2900009	6	Flat Washer, 1/4" SAE
18.3	2900310	6	Cap Screw, Hex Hd., M6 x 20mm
18.4	2900302	6	Lock Nut, M6 Nylon
19	1800001	1	Warning Label

**20" Blade Guard Assembly**  
**#6048904**

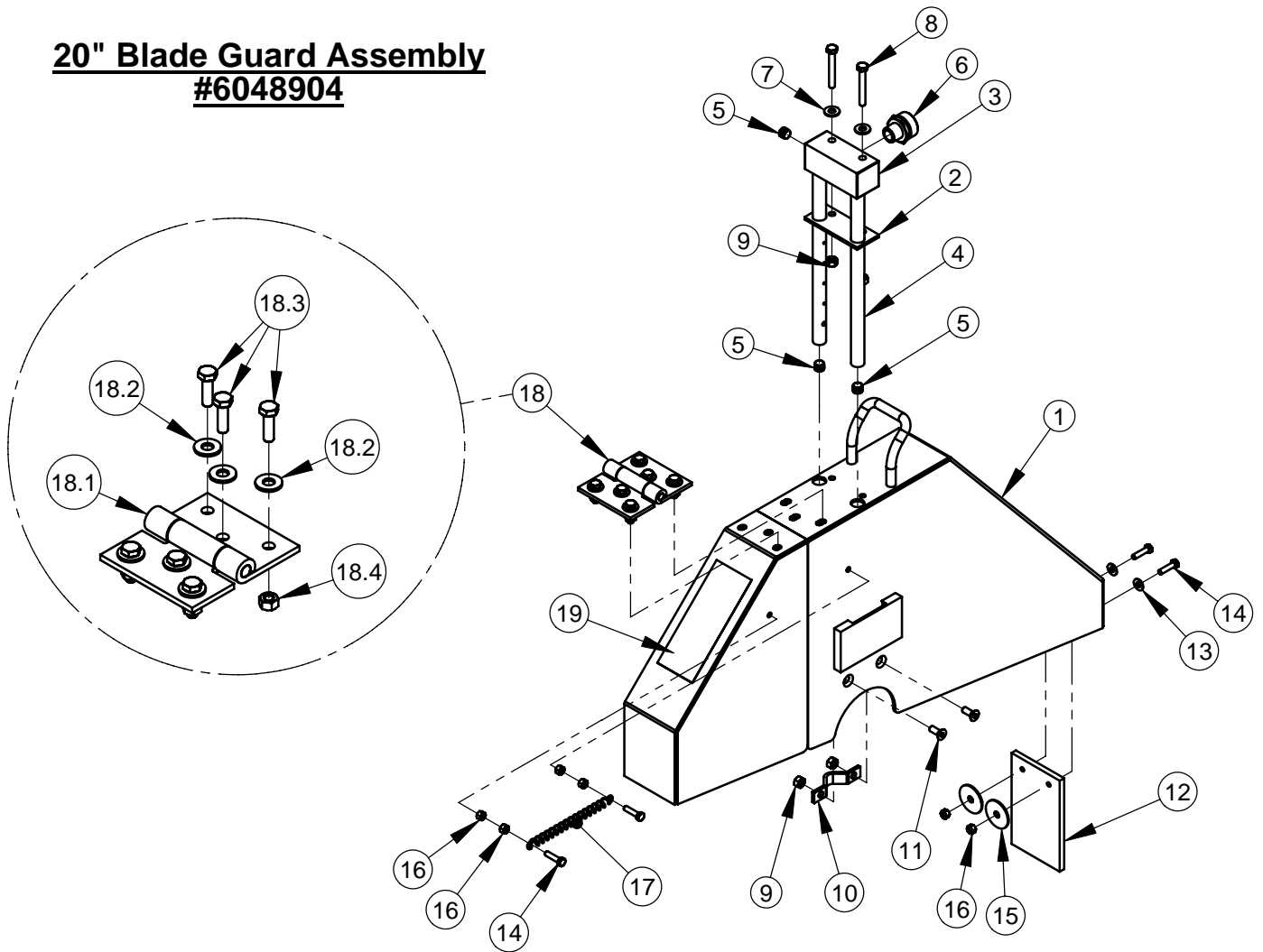

ITEM	PART NO.	QTY.	DESCRIPTION
1	6048905	1	20" Blade Guard
2	2500829	1	Water Manifold Gasket
3	6048123	1	Water Manifold
4	6010085	2	Water Tube for 20" Guard
5	3200001	3	Plug, 1/8" NPT
6	3200002	1	Fitting, 3/8" M. Pipe to 3/4" M. Garden
7	2900009	2	Flat Washer, 1/4" SAE
8	2900244	2	Cap Screw, Hex Hd., M6 x 45mm
9	2900302	6	Lock Nut, M6 Nylon
10	6048155	2	Water Tube Clamp
11	2900308	4	Cap Screw, Flat Hd. Soc., M6 x 16mm
12	6048039	1	Splash Flap
13	2900016	2	Flat Washer, #10 USS
14	2900309	4	Cap Screw, Hex Hd., M5 x 20mm
15	2900083	2	Fender Washer, 1/4" x 1-1/4"
16	2900301	6	Lock Nut, M5 Nylon
17	2500067	1	Spring, 3/8" x 4"
18	6048027	1	Hinge Assy., Metric Fasteners
18.1	2500270	1	Blade Guard Hinge
18.2	2900009	6	Flat Washer, 1/4" SAE
18.3	2900310	6	Cap Screw, Hex Hd., M6 x 20mm
18.4	2900302	6	Lock Nut, M6 Nylon
19	1800001	1	Warning Label

## 6048080 POINTER ASSEMBLY

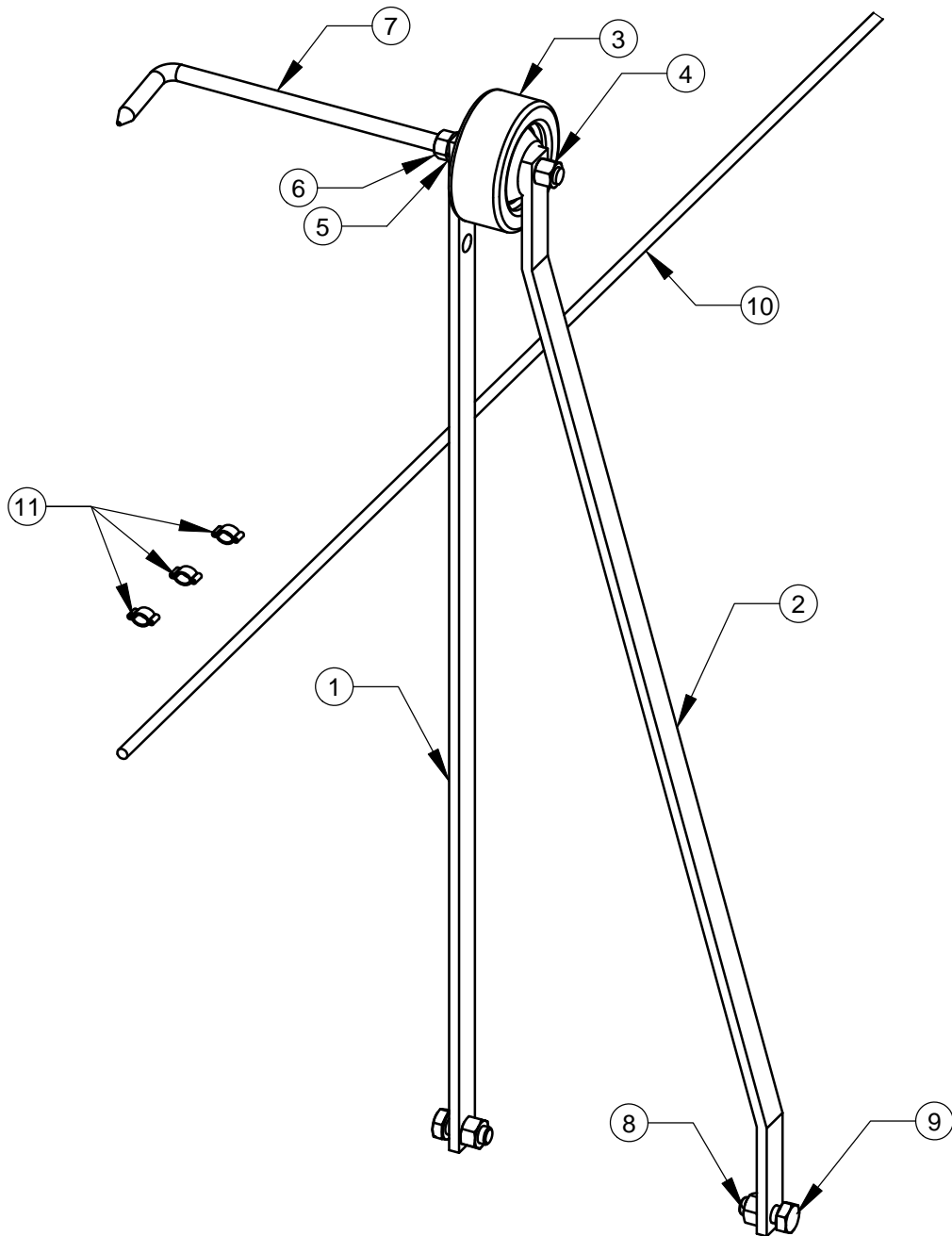

ITEM NO.	PART NUMBER	Default/ QTY.	DESCRIPTION
1	6048069	1	Pointer Bar - Straight
2	6048070	1	Pointer Bar - Offset
3	2500624	1	Wheel, 3"
4	2900018	1	Lock Nut, 3/8-16 Nylon
5	2900006	1	Lock Washer, 3/8" Split
6	2900033	1	Hex Nut, 3/8-16
7	2900032	1	Pointer Rod
8	2900304	2	Lock Nut, M10-1.5 Nylon Insert
9	2900333	2	Cap Screw, Hex Hd., M10-1.5 x 25mm
10	6048078	1	Rope, 1/4 x 78"
11	3200221	3	Pinch Clamp, Two Ear

## 6047994 POINTER ASSEMBLY, 10 HP UNITS

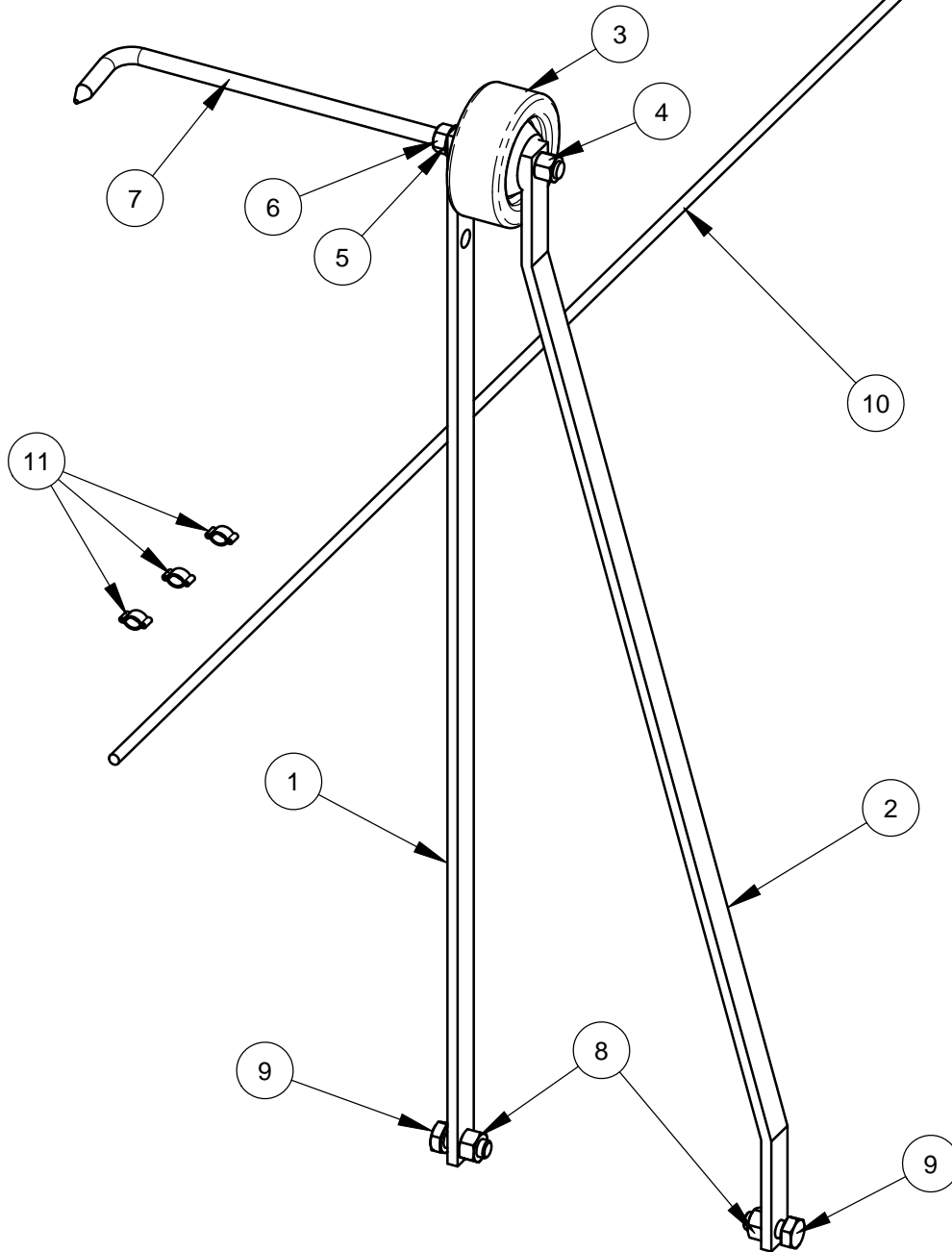

ITEM	PART NO.	Default/Q TY.	DESCRIPTION
1	6048069	1	Pointer Bar - Straight
2	6048070	1	Pointer Bar - Offset
3	2500624	1	Wheel, 3"
4	2900018	1	Lock Nut, 3/8-16 Nylon
5	2900321	1	Lock Washer, M10 Split
6	2900033	1	Hex Nut, 3/8-16
7	2900743	1	Pointer Rod, 11"
8	2900304	2	Lock Nut, M10-1.5 Nylon Insert
9	2900333	2	Cap Screw, Hex Hd., M10-1.5 x 25mm
10	6048078	1	Rope, 1/4 x 78"
11	3200221	3	Pinch Clamp, Two Ear

## EQUIPMENT AND PARTS WARRANTY

Diamond Products warrants all equipment manufactured by it against defects in workmanship or materials for a period of one (1) year from the date of shipment to Customer.

The responsibility of Diamond Products under this Warranty is limited to replacement or repair of defective parts at Diamond Products' Elyria, Ohio factory, or at a point designated by it, of such parts as shall appear to us upon inspection at such parts, to have been defective in material or workmanship, with expense for transportation and labor borne by Customer.

In no event shall Diamond Products be liable for consequential or incidental damages arising out of the failure of any Product to operate properly.

Integral units such as engines, electric motors, batteries, transmissions, etc., are excluded from this Warranty and are subject to the prime manufacturer's warranty.

**THIS WARRANTY IS IN LIEU OF ALL OTHER WARRANTIES, EXPRESSED OR IMPLIED, AND ALL SUCH OTHER WARRANTIES ARE HEREBY DISCLAIMED.**

