



DUSTLESS™ WET/DRY VACUUM HEPA VACUUM, AND TOOLSYNC™ TOOL ACTIVATED VACUUM OWNER'S MANUAL



Model's 16003, 16006,
16010, & 16011
16 Gallon

CONGRATULATIONS: You are now the owner of a Dustless™ Wet/Dry Vacuum which incorporates the latest advancements in wet/dry dust removal technology. This vacuum is engineered to eliminate the dust that has been a problem for so many years with wet/dry vacuums almost from their inception. This vacuum is different from anything in its category.

Once again **CONGRATULATIONS**

This cleaner was inspected and packaged carefully before being shipped from the factory.

If you should happen to need assistance during assembly or operation, call 1-800-568-3949 for our customer service department.

Serial Number _____
Model Number _____

Model and serial numbers are found on the side of the motor cover. You should record both model and serial numbers in a safe place for future use.

Dustless
TECHNOLOGIES

800.568.3949
1285 East 650 South
Price, Utah 84501
dustlesstechnologies.com

FULL ONE-YEAR WARRANTY ON DUSTLESS™ WET/DRY VACUUMS

If within one year from the date of purchase, this Dustless™ Wet/Dry Vacuum fails due to a defect in material or workmanship, Dustless Technologies will repair or replace it, free of charge. Please note that this warranty is limited to and applies only to the original purchaser "For Household Use Only," "POUR USAGE ME' NAGER TYPE MENAGER", so long as that use is in accordance with instructions and limitations set out in this manual.

If this Dustless™ Wet/Dry Vacuum is used for commercial or rental purposes, this warranty coverage applies for 90 days from date of purchase.

Warranty registration - Please fill out and return the warranty registration card accompanying your cleaner. Proof of purchase date will be needed for warranty work.

Obtaining Warranty Service - Warranty Service is available by simply contacting the factory at 1-800-568-3949.

This warranty gives you specific legal rights, and you may also have other rights which vary from state to state. There are no warranties, express or implied, written or verbal, which extend beyond the description in this manual.

FCC FCC ID: WP7DUSTWDV1

NOTE: This equipment has been tested and found to comply with the limits for a Class B digital device, pursuant to Part 15 of the FCC Rules. These limits are designed to provide reasonable protection against harmful interference in a residential installation. This equipment generates, uses and can radiate radio frequency energy and, if not installed and used in accordance with the instruction. Many cause harmful interference to radio communications. However, there is no guarantee that interference will not occur in a particular installation.

If this equipment does cause harmful interference to radio or television reception, which can be determined by turning the equipment off and on, the user is encouraged to try to correct the interference by one or more of the following measures:

- Reorient or relocate the receiving antenna.
- Increase the separation between the equipment and receiver.
- Connect the equipment into an outlet on a circuit different from that to which the receiver is connected.
- Consult the dealer or an experienced radio/TV technician for help.

CAUTION: Any changes or modification not express approved by Dustless Technologies, Inc. could void the user authorization to operate this equipment.

IMPORTANT SAFETY INSTRUCTIONS
IMPORTANTES MEDIDAS DE SEGURIDAD
IMPORTANTE PARA SU SEGURIDAD

SAVE THESE INSTRUCTIONS
CONSERVER CES INSTRUCTIONS
GUARDAR ESTA INSTRUCCIONES

- Read the Owner's Manual completely before attempting to operate this unit.
- Always check the filters before each use.
- Connect to a properly grounded outlet. See grounding instructions.
- Don't change filters, clean the unit, or empty the canister until the plug has been disconnected from the electrical outlet. Always unplug unit when not in use and before servicing.

WARNING – To avoid risk of electrical shock, do not use out doors or on wet surfaces.

Avertissement – Pour reduire les risques de choc electrique, ne pas utiliser a l'exterieur et ne pas aspirer de matieres humides.

Advertencia – Para reducir el riesgo de un electrochoque, no usarlo afuera o mojado.

WARNING – To reduce the risk of burns, fire, electric shock, or personal injury:

- Do not allow this unit to be used as a toy or to run unattended at any time. Keep children away from this unit.
- Do not use accessories except those recommended and provided by Dustless Technologies. Use this unit only for its intended use as described in this manual. Use of accessories not recommended by the manufacturer may cause fire, electric shock, or injury. (See parts list)
- Do not operate this unit in an enclosed space where flammable, explosive or toxic vapors are given off by oil-base paint, paint thinner, gasoline, etc.
- Do not vacuum toxic, carcinogenic, combustible, or other hazardous materials such as asbestos, arsenic, barium, beryllium, lead, pesticides, or other health endangering materials.
- To avoid the igniting of vapors or dust due to the arcing of the motor brushes, do not pick up flammable or readily combustible material.
- Do not expose your Vacuum to excessive heat as damage to your vacuum may occur and the 1 year warranty will be null and void.
- Do not pick up anything that is burning or smoking, such as cigarettes, matches, or hot ashes.
- Do not use without dust bag and/or filters in place.
- Do not pull unit by the suction hose.
- Do not abuse cord. Never carry your Vacuum by the cord or pull cord to disconnect it from the outlet. Grasp the plug, not the cord.
- Do not leave the cord lying on the floor once you have finished the cleaning job. It can become a tripping hazard.
- Never handle plug, cord, or cleaner with wet hands.
- Never drop or insert any objects into any openings. Do not use with any opening blocked; keep free of dust, lint, hair, and anything that may reduce air flow.
- Keep cord away from heat, oil and sharp edges. Do not close doors on the cord or snag it under furniture or pull around corners with sharp edges.
- The operation of a Wet/Dry Vacuum can result in foreign objects being blown into your eyes, which can result in eye damage. Always wear safety goggles when operating vacuum.
- Use special care when emptying heavily loaded canisters.
- Do not use outdoors or on wet surfaces. Do not leave appliance when plugged in. Unplug from outlet when not in use and before servicing. Do not use with damaged cord or plug if appliance is not working as it should, has been dropped, damaged, left outdoors, or dropped into water.
- Wear eye and hearing protection. Always use safety glasses. Everyday eyeglasses are NOT safety glasses. USE CERTIFIED SAFETY EQUIPMENT. Eye protection equipment should comply with ANSI Z87.1 standards. Hearing equipment should comply with ANSI S3.19 standards.

UNPACKING AND CHECKING CARTON CONTENTS

Remove entire contents of carton. Check each item against the Carton Contents List. Notify Dustless Technologies immediately if any parts are damaged or missing.

Carton Contents List

Key	Qty	Description
A	1	Lid Assembly
B	1	Intermediate Cover
C	1	Accessory Tray
D	1	Tank Assembly
E	2	Front Legs (smooth) & screws
F	2	Back Legs (with/ hooks) & screws
G	2	Extension wands
H	1	Crevice Tool Accessory
I	1	Wet/Dry Floor Tool Accessory
J	1	12' x 1 1/2" Hose
	1	Owner's Manual
	1	Warranty Card

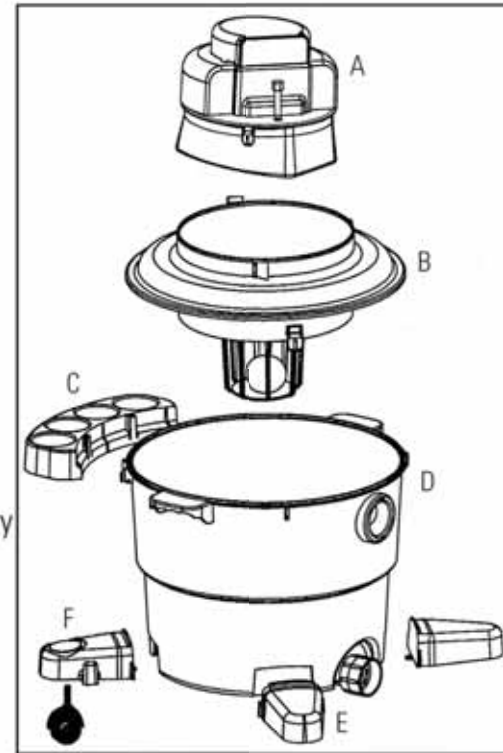

GROUNDING INSTRUCTIONS:

This appliance must be grounded. If it should malfunction or breakdown, grounding provides a path of least resistance for electric current to reduce the risk of electric shock. This appliance is equipped with a cord having an equipment - grounding conductor and grounding plug. The plug must be inserted into an appropriate outlet that is properly installed and grounded in accordance with all local codes and ordinances.

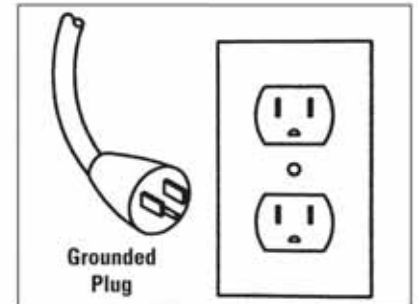

DANGER - Improper connection of the conductor can result in a risk of electric shock. Check with a qualified electrician or service person if you are in doubt as to whether the outlet is properly grounded. Do not modify the plug provided with the appliance.

NOTE: Static shocks are common in dry areas or when the relative humidity of the air is low. This is only temporary and does not affect the use of the Vacuum.

ASSEMBLY

To install the legs and accessory tray, undo the clips holding the intermediate cover in place and set the cover and lid assembly aside. Turn tank upside down. Front legs are on either side of the drain port opening. These front legs do not have the small hooks on either side. The back legs do have the hooks. These hooks are for the hose to rest on when in storage.

Align legs with openings provided on bottom of the canister and slide into place. The holes will only align in proper position for front and back legs. Insert black support screw into hole and tighten screw with a Phillips screwdriver.

Turn cleaner tank right side up.

Attach Accessory Tray

Align the three slots on the edge of the accessory tray with the three guides on the rear side of the tank and press the accessory tray toward the tank as you push the tray down. The two locking tabs will slide under the rim of the tank and catch. By pushing the tray down and toward the tank it will lock into place.

Place intermediate cover and lid assembly right side up and set on top of the tank. Attach the yellow clips from the tank onto the intermediate cover.

The Lid Assembly with the vacuum controls, motor, and filters are all preassembled at the factory for your convenience. Maintenance and replacement of filters is described later in this manual.

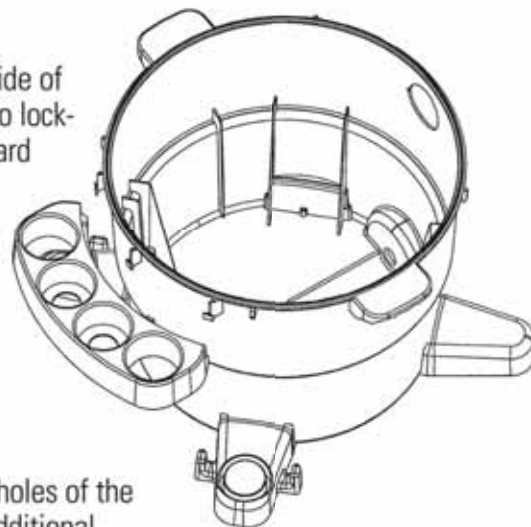

Attach hose, wands and cleaning accessories

Hose and accessories are stored on the unit. The hose will loop through the two outside holes of the accessory tray and rest on the hooks of the back legs as shown below. For convenience, additional accessories can be stored on tray when not in use.

To Use Accessories

Push hose into tank port; twist hose to tighten or loosen connection. The wands and cleaning accessories attach to hose in the same manner.

GENERAL INFORMATION

Dustless Technologies Model 16003 Wet/Dry Vacuum delivers 99% filtration at .5 micron which is great for fine particle pick-up, like drywall, concrete, or surface dust. All units come with a powerful 11 amp motor, dual filtration system, corrosion resistant tank, large wheels and an integrated accessory holder. Model 16010 comes with a built-in ToolSync outlet for use with power tools providing an automatic vacuum start-up when the tool is turned on and about a 6 second shut-off delay to clear the hose when the vacuum is turned off. Model 16006 Wet/Dry Vacuum has HEPA certified filters installed and provides filtration rated at D.O.P Eff. Mil. Std. 282: 99.97% min. at .3 micron. The Model 16011 HEPA Wet/Dry Vacuum comes with ToolSync.

The ToolSync model vacuums are intended for use with small hand held power tools with current rating 8 amperes or less. Accessories are available to allow larger tools to operate with the vacuum. See the ToolSync Operation section below for more information.



Automatic Suction Shut-Off

NOTE: The unit must be used in the upright position at all times, otherwise the automatic suction shut-off will activate. The automatic suction shut-off functions when the tank fills with liquid. As the tank fills, the ball float (inside the cage) rises until it seats itself against the bottom of the intermediate cover. This shuts off the suction of the vacuum cleaner when the tank is full.

ToolSync Vacuum Controls

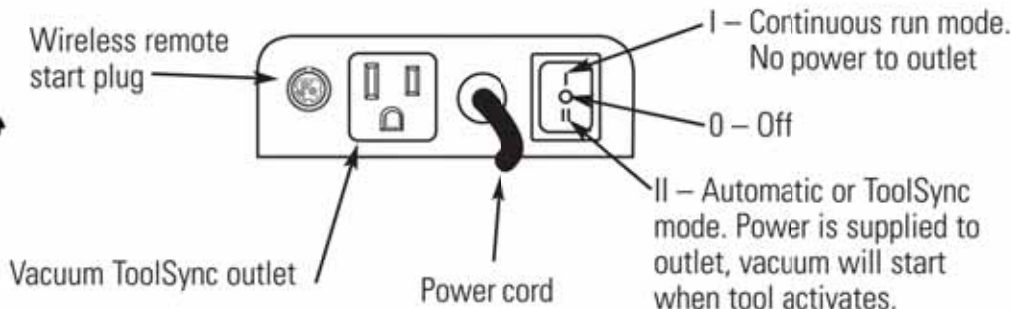

HOW TO USE

Extension cord instructions:

Use an outdoor, grounding type SJT extension cord of 16 gauge (up to 35 feet) or 14 gauge (any length). The extension cord must employ a 3-prong grounding type plug and a 3-pole receptacle that accepts the machine plug.

Filters

Do not operate cleaner without filters in place. To assure that your cleaner operates at peak performance, it is imperative that you use only genuine Dustless Technologies filters.

Regular Wet/Dry Vacuum Filters:

Primary and secondary filters should be held in place by their respective band clamps. There should not be any puckers or wrinkles that will allow dust to travel through or suction will be reduced. Micro Prefilter - Part #13141 is provided with each vacuum. Packages of 2 are available to purchase.

HEPA Filters:

It is recommended to use part #13141 - micro prefilter with your vacuum. Micro Prefilters #13141 are available. They are recommended to be used on any fine dust application such as sanding drywall. This is a disposable bag and should be thrown away when full.

How to Clean Filters:

Special note for HEPA filters: All HEPA filters should be discarded after use, no attempt to clean filters should be made.

Turn the unit off then remove the brass agitator rod cover from the top of the cleaner lid. The agitator rod will be exposed. Lift the agitator rod about 1/2 inch and rock from side to side. The lid acts as a pivot point for the filter support basket, located underneath the lid. The rocking motion of the basket agitates the primary filter to knock off the layer of dust that has accumulated. This will make the suction resume. After a period of time, when suction is reduced and cleaning the filters with the agitator rod is not sufficient, the filters may be replaced or laundered and reused.

Micro Prefilters are disposable and will hold 20-30 lbs. of dust.

How to Replace Filters:

Regular Wet/Dry Vacuum Filter assembly:

Turn vacuum lid upside down on a flat surface. Place the small, white secondary filter over the spring mounted cage on the underneath side of the lid. Gently push the filter all the way on and compress the springs, then let off all pressure allowing the cage to push the filter back out into a relaxed position. Secure filter firmly with the 7" band clamp to the lid so particles are not allowed to go through to the motor. Use a flat blade screwdriver for this clamp.



Take the filter support basket with agitator rod and turn it upside down. Put the agitator rod through the hole in the lid. The filter support basket rests on top of the secondary filter with the agitator rod through the lid hole.

Place the primary filter over the filter support basket and secondary filter. The side seam of the larger primary filter should line up with the filter support basket agitator rod and the filter is then put around the large lip on the underneath side of the lid and secured into place smoothly with the 10" band clamp. There should not be any wrinkles in the fabric as they will affect the functioning of the filters. The filter support basket is suspended between the two filters and the agitator rod extends through the top of the lid. Use a flat blade screwdriver for this clamp.

Turn right side up and screw the brass agitator rod cover into the top of the lid - only finger tight!! Do not over tighten.

HEPA Wet/Dry Vacuum

Filter assembly:

The HEPA Filter is placed over the crosspiece stud. The threads will protrude through the hole in the middle of the HEPA filter. Slide the provided rubber washer (part #91522) over the threads of the stud with the rubber side against the HEPA Filter. Screw down the wing nut (part #91523) and slightly compress the rubber washer. It will compress about 1/2 of its original thickness. Next place the HEPA Filter Cover Support on top of the HEPA filter and finally place the HEPA Filter Cover over the filter and cover. Attach the filter cover with the 10" band clamp using a flat blade screwdriver.

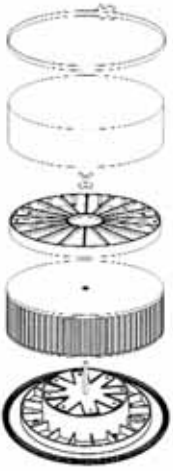

Turn right side up and screw the brass agitator rod cover into the top of the lid - only finger tight!! Do not over tighten. This part must be in place to maintain suction.

Dry Pickup:

Wet waste should be emptied from tank but filters can remain in place.

Connect suction hose and appropriate attachments for use. As suction is reduced from fine material coating the filters, shut off the unit to clean filters. Remove the brass agitator rod cover and rock the agitator rod from side to side to clean filters and resume suction.

After Dry Pickup:

Disconnect cleaner from electrical outlet. Release lid latches and remove cleaner lid assembly as well as intermediate cover from tank. Empty dry material from the tank and intermediate cover.

To avoid back strain, do not lift a full tank. First, scoop out enough debris to make tank easier to lift.

Empty contents into a suitable receptacle.

Wet Pickup:

Dry waste should be emptied from tank and intermediate cover but filters can remain in place.

Should filters become wet, during use, dry both filters thoroughly before continued use, consult the trouble shooting guide (Filters get wet).

After Wet Pickup:

Unscrew drain cap from bottom of tank. This drain is regulated so that a floor drain can be used conveniently. The liquid can be regulated from a drip to a full flow.

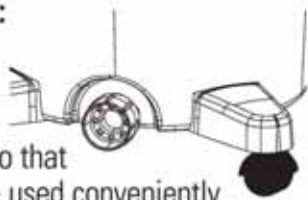

The suction hose can be put in the drain cap to drain liquid up to 12 feet away.

Rinse inside of tank thoroughly with clean water particularly if spills or other substances other than water have been picked up. Wipe inside of tank dry. Screw drain cap back on tightly so it is ready for use again.

Automatic Wet Shut-off:

When the tank is full of liquid, the automatic shut-off mechanism will shut off cleaner pick-up. When this happens, the motor sound will become noticeably higher in pitch. Turn cleaner off and empty tank to continue use.

Storage:

Disconnect cleaner from electrical outlet. Empty tank. Rinse inside of tank thoroughly with clean water particularly if spills or other liquid substances other than plain water have been picked up. Wipe inside of tank dry. If tank is stored with liquid left inside, the moisture may cause damage to the motor and its internal parts.

Wands and cleaning accessories as well as hose store right on the accessory tray. Wands store on each of the back leg grooves provided.

Lubrication:

The motor is equipped with bearings which contain sufficient lubrication for the life of the motor. The addition of lubricant could cause damage. Do not add lubricant to motor bearings.

If you have a problem:

This appliance was inspected thoroughly and was in good operating condition when it was shipped from the factory. If a minor problem occurs, it usually can be solved quite easily when the cause is found. Therefore, this Trouble Shooting Guide is provided for you convenience.

ToolSync Operation

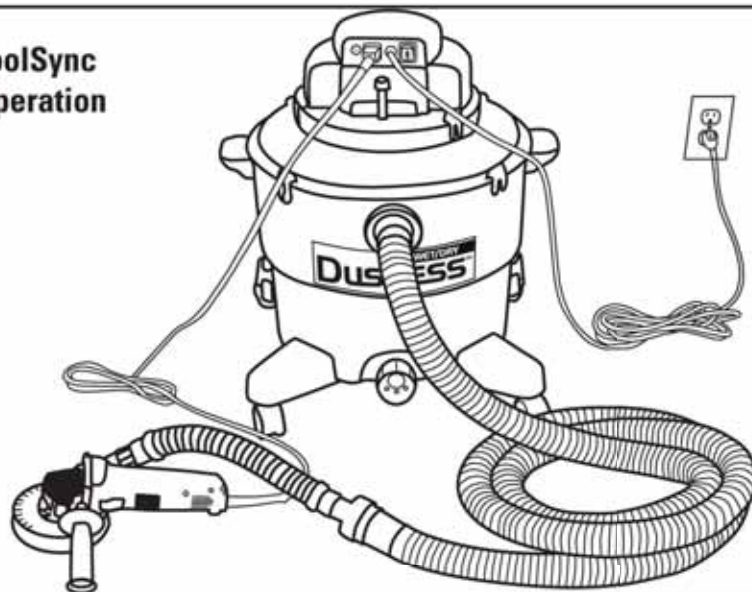

Wireless ToolSync Operation

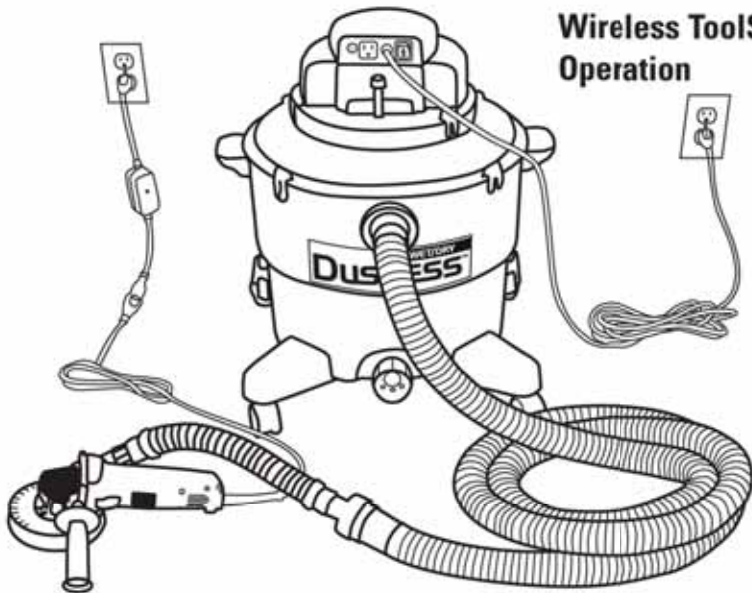

ToolSync Operation:

When the switch is in the I position, the vacuum will turn on but no power will be applied to the vacuum ToolSync outlet. When the switch is in the II position, power will be applied to the ToolSync outlet on the vacuum. When the portable electric tool is activated, the vacuum will turn on and run until the tool is turned off, then remain running for about 6 seconds to clear the hose. If the portable electric tool being used is rated 6-8 amps, the vacuum will reduce power to the vacuum to keep the total current to the tool and vacuum below 12 amps. The tool plugged into the vacuum will always receive full power. If a large tool is attached to the vacuum outlet, there may not be enough available current to supply the vacuum and the

vacuum motor will shut off. If this occurs, a remote/wireless electric start module will need to be used.

Some portable electric tools rated less than 1 amp may not trigger the automatic mechanism. When these low amperage tools come into contact with the work surface, they often draw enough current to activate the automatic start. When the vacuum is started with an attached tool, and the tool is turned immediately off (within 1-2 seconds), this will allow the vacuum to remain running in a "Clean-up mode". To clear "Clean-up mode", simply turn the tool on for more than 1-2 seconds, or turn the vacuum to the off position. "Clean-up mode" only works with a device plugged into the vacuum outlet.

Wireless Remote Start Operation:

There are 2 types of wireless start modules available. The pneumatic wireless start module is plugged inline with the air hose supplying air to a tool. When air flows, a wireless signal is transmitted to the vacuum to signal it to turn on. When the air flow stops, the vacuum is signaled to turn off after about a 6 second delay. The Electric wireless start module works in the same way as the pneumatic wireless start module except it plugs into a power outlet and measures current flow to signal the vacuum to operate. Both remote start modules have a red blinking light that signals the unit is transmitting

Note for Electric wireless start modules: When using large amperage devices and the wireless start power modules, it is important to plug the tool into a different circuit than that of the vacuum to avoid tripping a circuit breaker.

Note for Pneumatic wireless start modules: The Pneumatic wireless start module can send false signals if excessively jarred. It is best to mount the module on a wall or onto the hard lines. All Pneumatic wireless start modules are shipped without air fittings. The fittings on the module are a 3/8" FNPT tapered. Any fitting desired can be attached with pressures up to 150 psi.

Multiple wireless start modules:

The first time the vacuum receives a wireless signal, it will automatically recognize that and only that device that send the signal. Each vacuum has the ability to learn to operate on a specific set of wireless start modules (up to 16). For a

vacuum to recognize multiple wireless start modules, the following training procedure must be followed. The training/reset plug shown below will be required for the following procedures. Note that the training plug is not included with the vacuum and is available through Dustless Technologies.

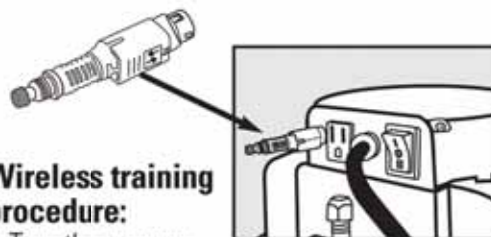

Wireless training procedure:

1. Turn the vacuum off. (O on the switch)
2. Insert the training/reset plug.
3. Switch the vacuum to the automatic or II position. (Do NOT push in the red button)
4. The vacuum will now be waiting for a remote start and will learn the next wireless signal that it receives.
5. Activate the wireless start module. Once the vacuum has turned on, that wireless start module has been learned.
6. As long as the training plug is in the vacuum, it will learn or recognize all wireless start modules.
7. When training is complete, remove the training plug.

The vacuum can also be reset back to factory defaults by executing the following reset procedure. In factory default mode, the vacuum does not recognize any wireless start modules. The first time the vacuum receives a wireless signal, it will automatically recognize that and only that device.

Wireless reset procedure:

1. Turn the vacuum off. (O on the switch)
2. Insert the training/reset plug.
3. Press the red button in on the training/reset plug.
4. While holding in the red button, switch the vacuum to the automatic or II position. When the vacuum turns on, it has been reset.
5. Turn the vacuum off, and remove the training/reset plug.

After resetting the vacuum, all previously recognized devices will need to be retrained according to the above training procedure.

One Wireless Start module controlling multiple vacuums:

It is possible for one wireless start module to control multiple vacuums. To do this, reset both vacuums, activate the remote start module so it starts transmitting, then turn the vacuums on. They will be trained to the first wireless signal received. If this condition is not desired, reset both vacuums and train them to individual wireless start modules.

Multiple Vacuum and Multiple Wireless Start Modules:

It is possible for each vacuum to recognize 16 unique modules. This can be achieved by systematically training one vacuum with associated wireless start modules, then moving on to the next vacuum. Care must be taken when training multiple vacuums to ensure that only one vacuum is being trained at a time along with only one wireless start module being activated at a time.

TOOLSUNC TROUBLE SHOOTING GUIDE

Problem	Possible Cause	Possible Solution
Tool will not start when plugged into vacuum	Switch in wrong position	Switch must be in II or auto-start position
Vacuum will not start when the tool starts	Tool draws too little current Tool draws too much current	Make contact with work surface to draw more current Use a remote start module
Wireless module will not start vacuum	Module has not been trained for this vacuum	Go through training procedure
Wireless module lights are not blinking when tool activates	Tool drawing too little current Drawing plenty of current but still not transmitting	Make contact with work surface to draw more current Try another tool, if unsuccessful contact customer support

TROUBLE SHOOTING GUIDE

Problem	Possible Cause	Possible Solution
Cleaner won't run	Not firmly plugged in No voltage in wall plug Blown fuse/tripped breaker	Plug in unit firmly Check fuse or breaker Replace fuse/reset breaker
Loss of suction	Obstruction in hose in place Coated primary filter Coated secondary filter Hole/split in hose Tank is full Unit tipped over Micro Prefilter is full	Clean obstruction Clean Filter with cleaning agitator rod Remove primary filter and replace/laundry both filters Inspect and replace hose Empty tank of waste Put unit in upright position Dispose of filter and debris.
Using Agitator Rod does not clean filters (Non-HEPA vacuum)	Too much debris around the primary filter Both filters plugged	Empty debris from intermediate cover and tank Replace or laundry both filters.
Filters get wet	Drain cap not sealed O-ring on drain cap not in place Debris not emptied from tank before use	Tighten drain cap Replace o-ring Empty tank and intermediate cover of waste **Always dry filters thoroughly before continued use
Unit blows dust	Filters not in place Hole in filter/s Secondary filter not in place Primary filter not in place	Check filters Check/replace filters Check secondary filter Check primary filter

ACCESSORIES AVAILABLE

(not to scale)

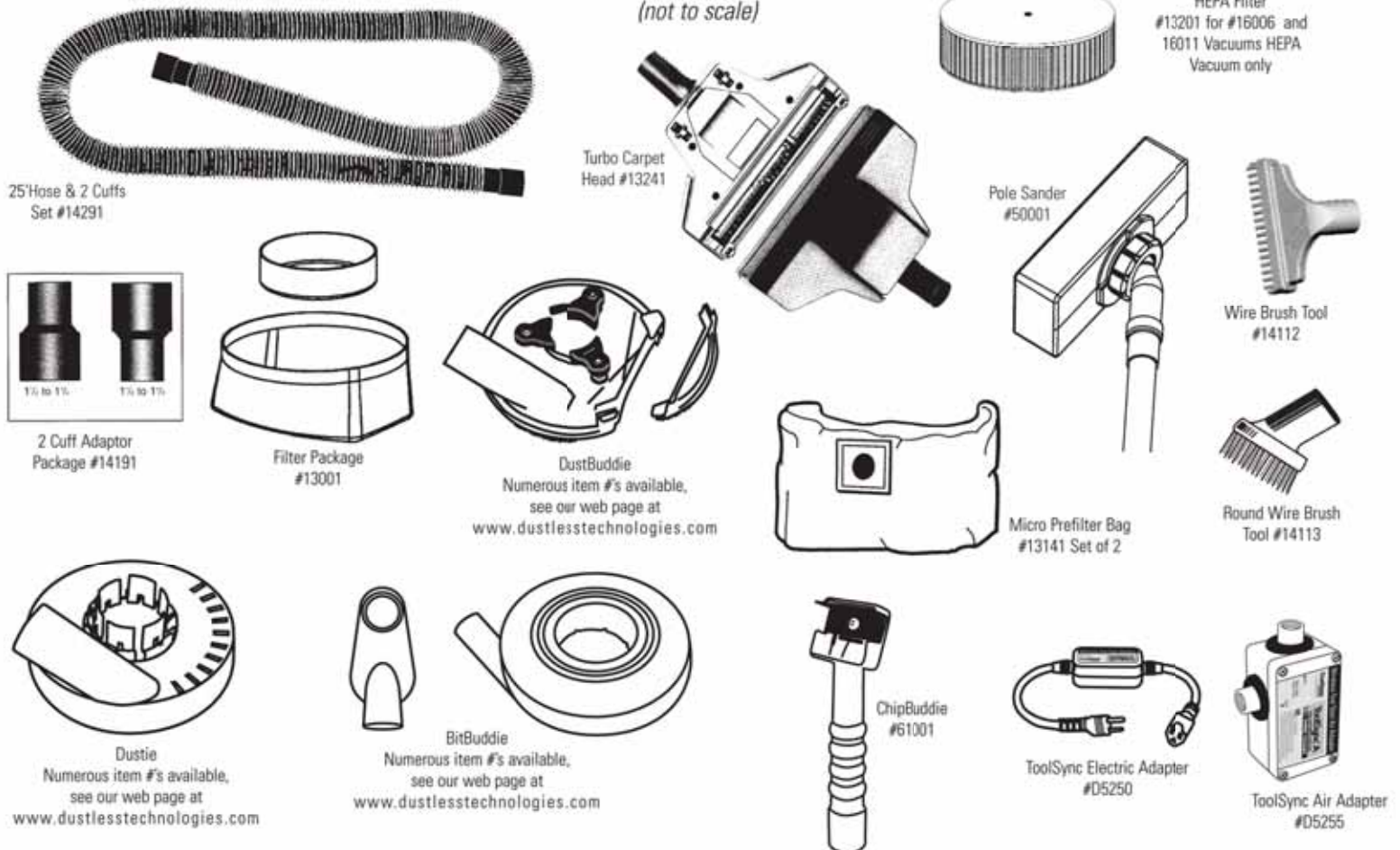

Parts List

Key	Part No.	Qty.	Description
1	04503	1	Brass Agitator Rod Cover
2	01154	1	Motor Cover
2a	01153	1	Motor Cover (ToolSync Model)
161062	3	1	Electric Cord
	3a	1	Electric Cord (ToolSync Model)
161064	4	1	On/Off switch
	4a	1	On/Off switch (ToolSync Model)
	5a	1	ToolSync Outlet
	6a	1	ToolSync PCB (with connecting wires)
	7	1	Motor hold down tab (Not shown)
161069	8	1	Motor
	9	1	Pink Connector (Not shown)
	10	2	Hex Head Screws (Not shown)
	11	4	2" Screws
	12	1	Vac Lid
160147	13	3	Lid Clamps
Wet/Dry Vacuum			
	14	4	Springs
	15	1	Cage
	16	4	Silver Shoulder Screws
	17	1	Secondary Filter
	18	1	7" Hose Clamp
160976	19	1	Filter Support with Agitator Rod
	20	1	Primary Filter
160977	21	1	10" Band Clamp
HEPA Vacuum			
	14H	1	Crosspiece
	15H	8	Black Pan Head Screws
	16H	1	HEPA Filter
	17H	1	HEPA Filter Cover Support
	18H	1	HEPA Filter Cover
	19H	1	Rubber Washer
	20H	1	Wing Nut
	21H	1	HEPA 10" Band Clamp
161084	22	1	Intermediate Cover
	13	4	Lid Clamps
	23	1	Float Ball
	24	1	Float Ball Basket
151313	25	1	Accessory Tray
161104	26	1	Barrel & Port assy
160928	27	1	Barrel Intake Port
160148	28	2	Front Legs (smooth)
160149	29	2	Back Legs (w/hooks)
	30	4	Casters & Stem
160150	31	1	Drain Cap
161091	32	1	Drain Cap O-Ring
160151	34	2	Extension Wands
160152	35	1	Crevice Tool Accessory
160153	36	1	W/D Floor Tool Accessory
	37	1	Owner's Manual (not illustrated)
	38	1	Warranty Card (not illustrated)
	39	1	3/8" Black Pan Head Screws
160152	40	1	12' x 11/2" Hose
	41	3	9/16" Black Pan Head Screws

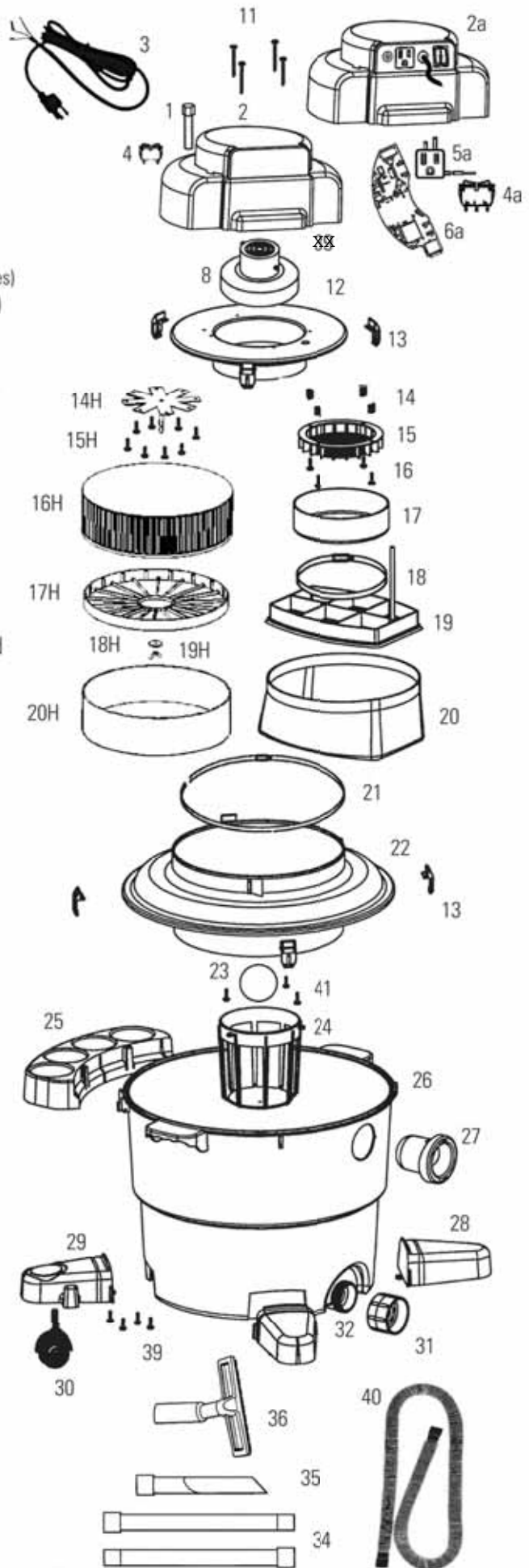

Service

To obtain approved Dustless Technologies service and parts, call: 1-800-568-3949.
 Please reference: Part Number, Description, Model Number, Name of Unit.
 Phone (435) 637-5885 • Fax (435) 637-5895 • www.dustlesstechnologies.com