

STARTING
SERIAL # 190710055

PARTS LIST MANUAL

MODEL DS20



GASOLINE MODEL



ELECTRIC MODEL

20" DOWNCUT - PROFESSIONAL WALK-BEHIND SAWS FOR CONCRETE AND ASPHALT

SKU #	MODEL #	POWER OPTION
30100	DS20-390	HONDA GASOLINE ENGINE MODEL GX390
30300-230	DS20-7.5B/230/3	BALDOR ELECTRIC MOTOR 7.5HP 230V 3-PHASE
30300-460	DS20-7.5B/460/3	BALDOR ELECTRIC MOTOR 7.5HP 460V 3-PHASE

**READ AND UNDERSTAND THE OPERATOR'S SAFETY MANUAL THOROUGHLY
BEFORE ATTEMPTING TO OPERATE THIS EQUIPMENT.**

Death or serious injury could occur if this machine is used improperly.

Machine specific Operator's Instruction Manuals are offered at edcoinc.com/customer-resources/manuals-parts-lists/
READ AND UNDERSTAND THE ENGINE MANUFACTURERS INSTRUCTIONS AND OPERATORS MANUAL BEFORE OPERATION.



EQUIPMENT DEVELOPMENT COMPANY, INC.
100 Thomas Johnson Drive, Frederick, MD 21702-4600 USA
Phone: 800-638-3326 or 301-663-1600 • Fax: 800-447-3326 or 301-663-1607
Website: www.edcoinc.com • E-mail: techsupport@edcoinc.com

Printed in USA
dks ©2020



SAFETY INFORMATION



SAFETY MESSAGES

• Safety Instructions are preceded by a graphic alert symbol of DANGER, WARNING, or CAUTION.

DANGER

Indicates an imminent hazard which, if not avoided, will result in death or serious injury.

WARNING

Indicates an imminent hazard which, if not avoided, can result in death or serious injury.

CAUTION

Indicates hazards which, if not avoided, could result in serious injury and or damage to the equipment.

GASOLINE / PROPANE POWERED EQUIPMENT

WARNING

• Engine exhaust from this product contains chemicals known to the State of California to cause cancer, birth defects or other reproductive harm.

WARNING

• Tilting a gasoline powered machine fitted with an EPA approved vented charcoal filter gas cap, beyond 20° can cause fuel leakage. If a leak occurs, do not start or run the engine until the leak is fixed. Eliminate all other ignition sources in the immediate area (no smoking, flares, sparks or flames). Use approved gasoline absorbing material to contain the fuel leakage. Then use clean, non-sparking tools to collect absorbed materials then dispose of these contaminants properly.



• Gasoline is extremely flammable and poisonous. It should only be dispensed in well ventilated areas, and with a cool engine.

• Small gasoline engines produce high concentrations of carbon monoxide (CO) example: a 5 HP 4 cycle engine operation in an enclosed 100,000 cu. ft. area with only one change of air per hour is capable of providing deadly concentrations of CO in less than fifteen minutes. Five changes of air in the same area will produce noxious fumes in less than 30 minutes. Gasoline powered equipment should not be used in enclosed or partially enclosed areas. Symptoms of CO poisoning include, head-ache, nausea, weakness, dizziness, visual problems and loss of consciousness. If symptoms occur - get into fresh air and seek medical attention immediately.

- Never refuel a hot engine or an engine while it is running.
- Engines are shipped from factory without fuel/oil.



• Propane is extremely flammable and is heavier than air and tends to settle in low areas where a spark or flame could ignite gas. DO NOT start or operate this propane engine in a poorly ventilated area where leaking propane gas could accumulate and endanger safety of persons in area. If headache develops, shut off machine. Have it checked for carbon monoxide emissions by a qualified technician before using it again. To ensure personal safety, installation and repair of propane fuel supply systems must be performed only by qualified technicians. Carbon monoxide emissions from this machine are greatly increased due to a dirty combustion air cleaner.

ELECTRICAL POWERED EQUIPMENT



Extreme care must be taken when operating electric models with water present: Ensure power cord is properly grounded, is attached to a Ground-Fault-Interrupter (GFI) outlet, and is undamaged.

- Check all electrical cables - be sure connections are tight and cable is continuous and in good condition. Be sure cable is correctly rated for both the operating current and voltage of this equipment.
- Improper connection of the equipment grounding conductor can result in a risk of electric shock. Check with qualified electrician or service person if there is any doubt as to whether the outlet is properly grounded. Adhere to all local codes and ordinances.
- NOTE: In the event of a malfunction or breakdown, grounding provides a path of least resistance for the electric current to dissipate. The motor is equipped with a grounded plug and must be connected to an outlet that is properly installed and properly grounded. DO NOT modify the plug provided on the motor. If the plug does not fit the outlet have a qualified electrician install the proper receptacle.

ELECTRICAL POWERED EQUIPMENT CONTINUED

- Do not disconnect power by pulling cord. To disconnect, grasp the plug, not the cord.
- Unplug power cord at the machine when not in use and before servicing.
- Switch motor OFF before disconnecting power.
- Never use frayed, damaged, taped or under rated extension cords. Electrical shock could result in death or serious injury to the operator and damage to the equipment.
- Assure you are using the proper extension cord length.

GENERAL INSTRUCTIONS

- Equipment should only be operated by trained personnel in good physical condition and mental health (not fatigued). The operator and maintenance personnel must be physically able to handle the bulk weight and power of this equipment.
- This is a one person tool. Maintain a safe operating distance to other personnel. It is the operators' responsibility to keep other people (workers, pedestrians, bystanders, etc.) away during operation. Block off the work area in all directions with roping, safety netting, etc. Failure to do so may result in others being injured by flying debris or exposing them to harmful dust and noise.
- This equipment is intended for commercial use only.
- For the operator's safety and the safety of others, always keep all guards in place during operation.
- Never let equipment run unattended.



- Personal Protection Equipment and proper safety attire must be worn when operating this machinery. The operator must wear approved safety equipment appropriate for the job such as hard hat and safety shoes when conditions require. Hearing protection MUST be used when operational noise levels of this equipment may exceed 85db. Eye protection MUST be worn at all times.



Keep body parts, loose clothing and accessories away from moving parts. Failure to do so could result in dismemberment or death.

- Do not modify the machine.
- Stop motor/engine when adjusting or servicing this equipment. Maintain a safe operating distance from flammable materials. Sparks from the cutting-action of this machine can ignite flammable materials or vapors.



DUST WARNING

WARNING

Some dust created by power sanding, sawing, grinding, drilling, and other construction activities contains chemicals known to cause cancer, birth defects, or other reproductive harm. Materials being removed can be toxic or hazardous. A breathing respirator is required to help protect the operator.

Some examples of these chemicals are:

- Lead from lead-based paints.
- Crystalline silica from bricks, concrete and other masonry products. Your risk of exposure to these chemicals varies depending on how often you do this type of work. To reduce your risk: work in a well ventilated area, use a dust control system, such as an industrial-style vacuum, and wear approved personal safety equipment, such as a dust/particle respirator designed to filter out microscopic particles.
- See more on the importance of dust prevention and silica warnings at: osha.gov/silica
- More concrete and silica dust suppression training and educational materials available at edcoinc.com/silica-standards or scan the QR code on page 5.
- Written exposure plans are provided at <http://www.edcoinc.com/written-exposure-control-plans/>

PARTS LIST MANUAL

MODEL DS20

TABLE OF CONTENTS

	Pages
Safety Information	2
How To Order Replacement Parts	3
Illustration 1: Main Grouping	4, 5
Illustration 2: Arbor & Blade Guard Grouping	6, 7
Illustration 3: Handle Bar Assembly 300007 & 300008	8
Illustration 4: Handwheel Subassy. 56331	9
Illustration 5: Fork Assembly 300009	10
Illustration 6: Guide Bar Assembly 300010	10
Illustration 7: Blade Guard Assembly 300013	11
Illustration 8: Engine Grouping	12, 13
Illustration 9: Engine Assembly 300011	14
Wiring Diagram for Honda Engine	15
Illustration 10: 7.5 HP Motor Grouping	16, 17
Illustration 11: 7.5 HP Motor Assembly 300032 & 300033	18, 19
Illustration 12: Reset Starter Assembly 16454 & 16459	20
Illustration 13: Remote Switch Assembly 16660	21
Wiring Diagram for Starter and Remote Switch	22
Wiring Diagram for 7.5HP Motor	23
Illustration 14: Optional Water Tank Assembly 56310	24
Decals	25, 26
Limited Equipment Warranty of Sale	27
STOP Before Using This Product	28

HOW TO ORDER REPLACEMENT PARTS

- ❑ To insure product safety and reliability, always use genuine EDCO replacement parts when making repairs to the equipment.
- ❑ When calling for parts, specify the MODEL and SERIAL number of the machine, which can be found on the NAME PLATE. Keep that information in the space provided. In addition to this information, give part number, description, and quantity as listed on the parts list to your parts representative.
- ❑ Please note: Due to improvements and changes in the equipment, the illustrations shown may be different than the actual machine.

FILL IN INFORMATION BELOW

Date of Purchase _____

Model # _____

Serial # _____

SKU # _____

ILLUSTRATION 1: MAIN GROUPING

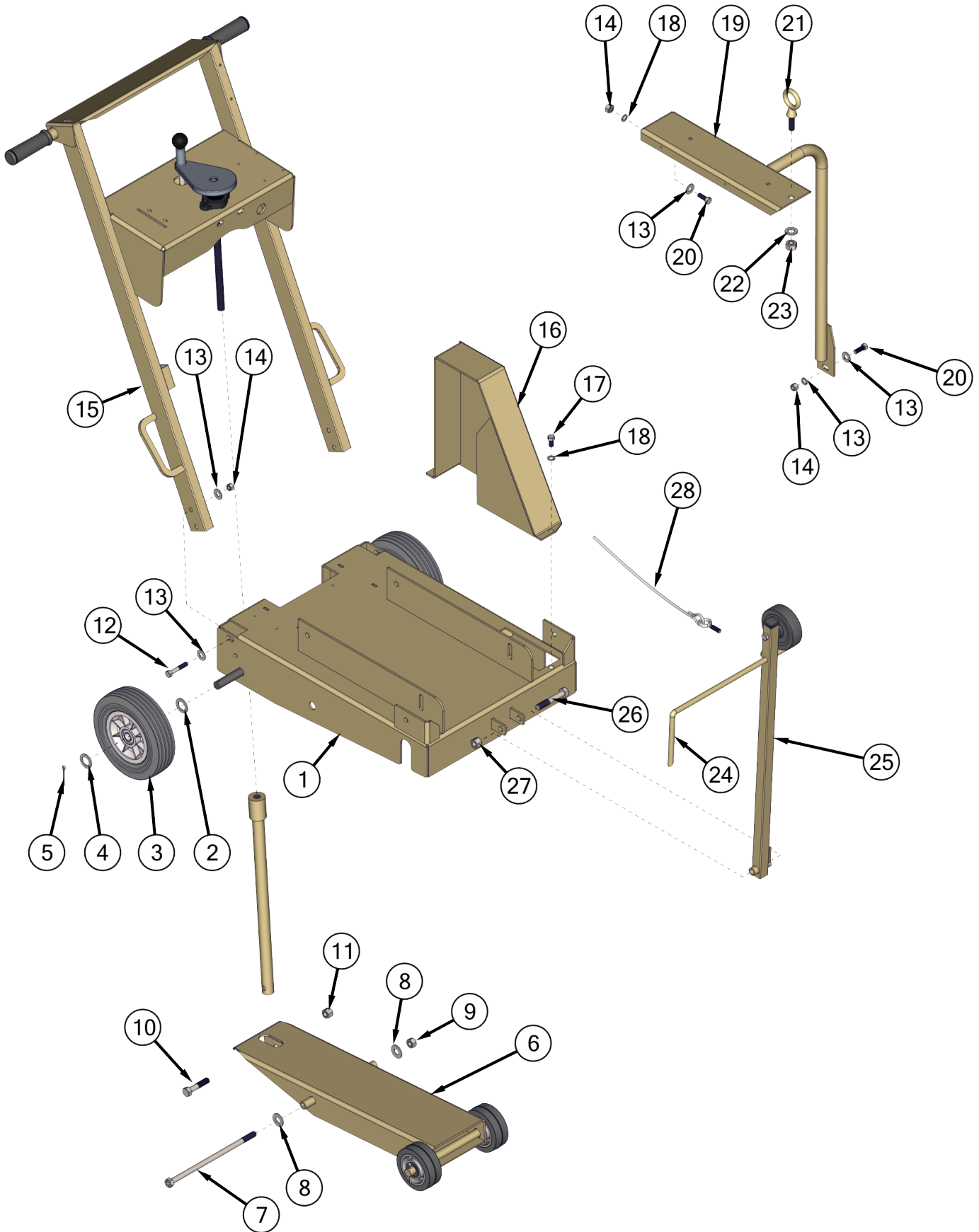

PARTS LISTING - ILLUSTRATION 1: MAIN GROUPING			
ITEM	PART #	DESCRIPTION	QTY.
1	100210	MAIN FRAME WELDMENT	1
2	10009	WASHER, FLAT 3/4 SAE ZINC	2
3	79013	WHEEL, 8 X 2-1/2 X 3/4"BRG.POLY HUB	2
4	11597	WASHER .755"ID X 1.25"OD X .060"THK	2
5	10306	PIN, COTTER 3/16 X 1-1/2	2
6	300009	FORK ASSEMBLY (SEE PAGE 10)	1
7	65239	SCREW, CAP 1/2-13 X 10	1
8	10312	WASHER, FLAT 1/2 SAE ZINC	2
9	10407	NUT, HEX LOCK 1/2-13 ZINC	1
10	10347	SCREW, CAP 1/2-20 X 2-1/4	1
11	10154	NUT, HEX NYLON LOCK 1/2-20 ZINC	1
12	10317	SCREW, CAP 3/8-16 X 2	4
13	10025	WASHER, FLAT 3/8 SAE ZINC	11
14	10156	NUT, HEX NYLON LOCK 3/8-16 ZINC	7
15	300007	HANDLE BAR ASSEMBLY, DS20 GASOLINE (SEE PAGE 8)	1
	300008	HANDLE BAR ASSEMBLY, DS20 ELECTRIC (SEE PAGE 8)	1
16	56206	BELT COVER WELDMENT	1
17	10907	SCREW, CAP 3/8-16 X 3/4	2
18	10811	WASHER, LOCK 3/8 ZINC	4
19	100132	LIFTING BAIL WELDMENT	1
20	10055	SCREW, CAP 3/8-16 X 1	3
21	10837	BOLT, EYE 1/2-13 X 1-1/2 X 1-1/8"ID	1
22	10312	WASHER, FLAT 1/2 SAE ZINC	1
23	10155	NUT, HEX NYLON LOCK 1/2-13 ZINC	1
24	100131	GUIDE POINTER, FRONT	1
25	300010	GUIDE BAR ASSEMBLY (SEE PAGE 10)	1
26	10499	SCREW, CAP 1/2-13 X 3	1
27	10155	NUT, HEX NYLON LOCK 1/2-13 ZINC	1
28	56221	GUIDE BAR ROPE ASSEMBLY	1

ILLUSTRATION 2: ARBOR & BLADE GUARD GROUPING

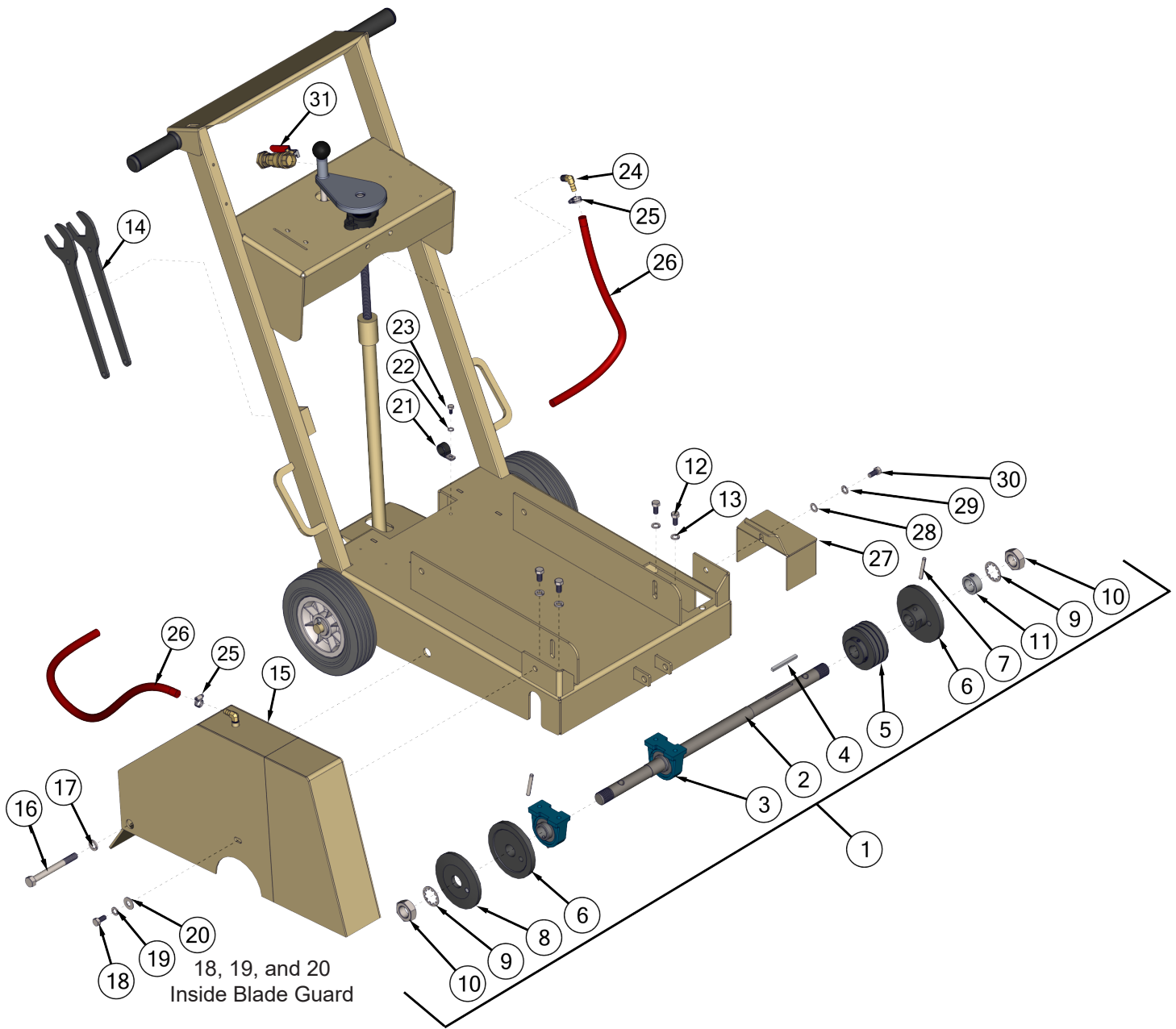

PARTS LISTING - ILLUSTRATION 2: ARBOR & BLADE GUARD GROUPING

ITEM #	PART #	DESCRIPTION	QTY.
1	100224	ARBOR ASSY. COMPLETE 20" MODEL	1
2	56208	ARBOR SHAFT 23-3/8"L	1
3	50222	BEARING, BALL 1" TPB	2
4	100155	KEY 1/4SQ X 2-1/2	1
5	56235	SHEAVE 3.35"OD X 3GR.3V X 1"BORE SHEAVE	1
6	56026	ARBOR BACKING PLATE 4"	2
7	10211	PIN, ROLL 5/16 X 2	2
8	56025	ARBOR BLADE CAP 4"OD W/1"HOLE	1
9	55009	WASHER, LOCK, INT. TOOTH 1"	2
10	50019	NUT, HEX JAM 1-14 ZINC GRADE A	2
11	10427	COLLAR, LOCKING 1"ID	1
12	10907	SCREW, CAP 3/8-16 X 3/4	4
13	10811	WASHER, LOCK 3/8 ZINC	4
14	50445	WRENCH, ARBOR, 1-1/2" OPEN END	2
15	300013	BLADE GUARD ASSY. COMP. 20" (SEE PAGE 11)	1
16	10386	SCREW, CAP 1/2-13 X 4-1/2	1
17	10045	WASHER, LOCK 1/2 ZINC	1
18	10907	SCREW, CAP 3/8-16 X 3/4	1
19	10811	WASHER, LOCK 3/8 ZINC	1
20	10025	WASHER, FLAT 3/8 SAE ZINC	1
21	11565	CLAMP, LOOM, 5/8" (SAE SIZE 10)	1
22	10038	WASHER, LOCK 1/4 ZINC	1
23	10846	SCREW, CAP STSHW 1/4-20 X 5/8	1
24	10799	BARB ELBOW 90, 3/8HOSE X 1/4MPT	1
25	10714	CLAMP, HOSE, SAE #4, ADJ. TO 5/8"	2
26	100214	HOSE, WATER 3/8"ID X 54"L	1
27	100138	ARBOR COVER WELDMENT	1
28	10025	WASHER, FLAT 3/8 SAE ZINC	1
29	10811	WASHER, LOCK 3/8 ZINC	2
30	10907	SCREW, CAP 3/8-16 X 3/4	2
31	10711A	VALVE & HOSE CONNECTOR ASSY.	1

**ILLUSTRATION 3: HANDLE BAR ASSEMBLY
(300007 GAS, 300008 ELECTRIC)**

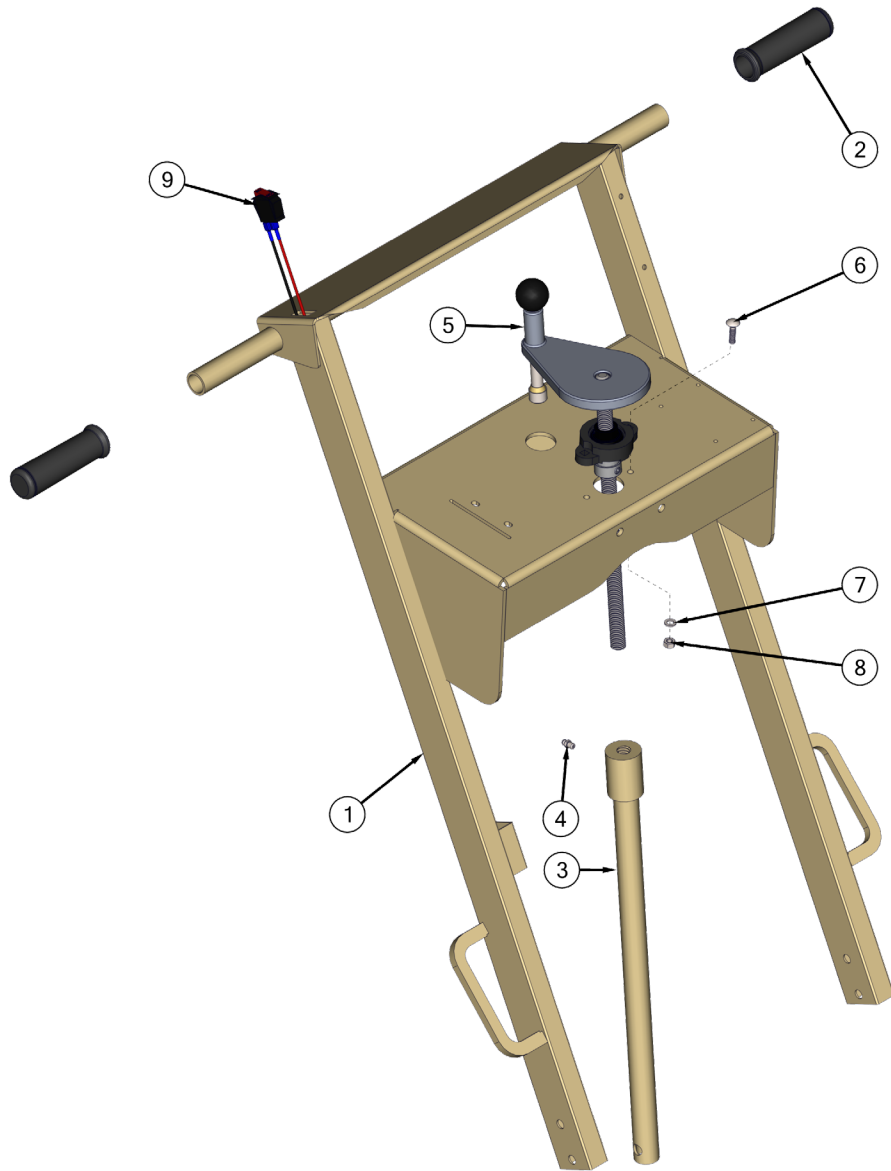

ITEM	PART #	DESCRIPTION	QTY.
1	100211	HANDLEBAR WELDMENT	1
2	10608	GRIP, HAND 1" MODEL AT	2
3	100128	LINKAGE WELDMENT, CUT CONTROL DS	1
4	10808	FITTING, GREASE 1/4-28 STRAIGHT	1
5	56331	HANDWHEEL SUBASSY (SEE PAGE 9)	1
6	10412	BOLT, CARRIAGE 1/4-20 X 1	2
7	10602	WASHER, FLAT 1/4 SAE ZINC	2
8	10150	NUT, HEX NYLON LOCK 1/4-20 ZINC	2
9	15201A 15204	SWITCH W/ WIRES, ROCKER ON-OFF (GAS) PLUG, RECT. HOLE, PLASTIC SNAP-IN (ELECTRIC)	1 1

ILLUSTRATION 4: HANDWHEEL SUBASSY. 56331

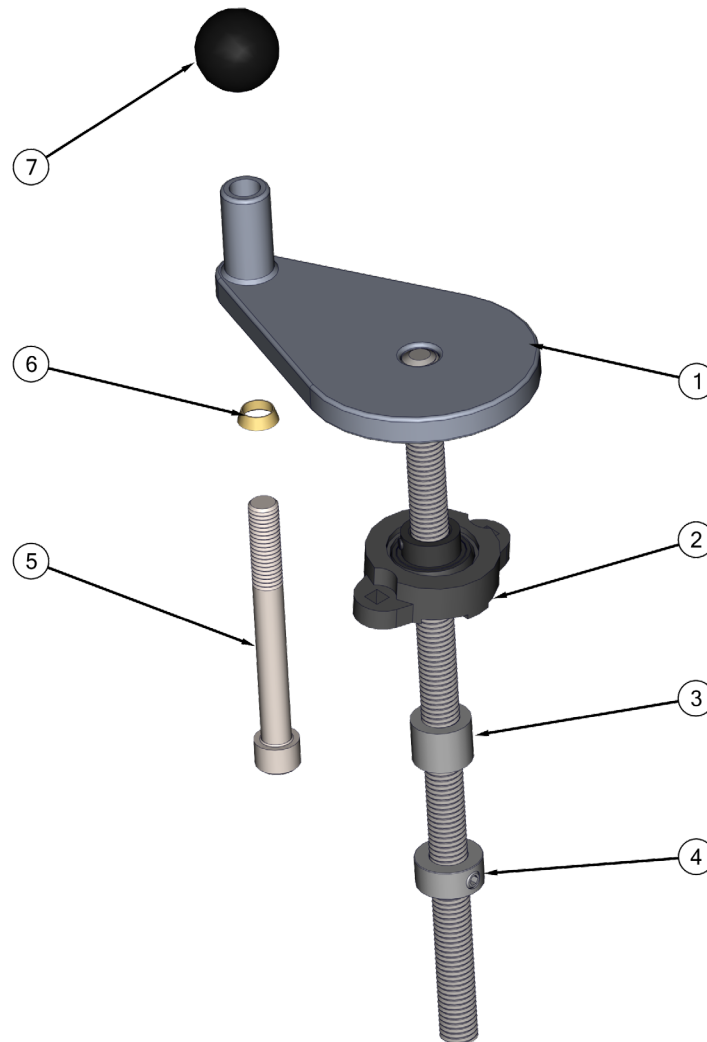

ITEM	PART #	DESCRIPTION	QTY.
1	51075	HANDWHEEL, LARGE W/ 5/8-8 X 13"ROD	1
2	80009	BEARING, BALL 5/8" 2-HOLE (NO G.F.)	1
3	55010	SPACER, HANDWHEEL, 3/4"L	1
4	10096	COLLAR, LOCKING 5/8"ID	1
5	10346	SCREW, SKT. HD. CAP 1/2-13 X 4-1/2	1
6	50550	SLEEVE, BRASS 1/2" TAPERED	1
7	14023	KNOB, BALL 1-3/8 W/ 1/2-13THD, BLK.	1

ILLUSTRATION 5: FORK ASSEMBLY 300009

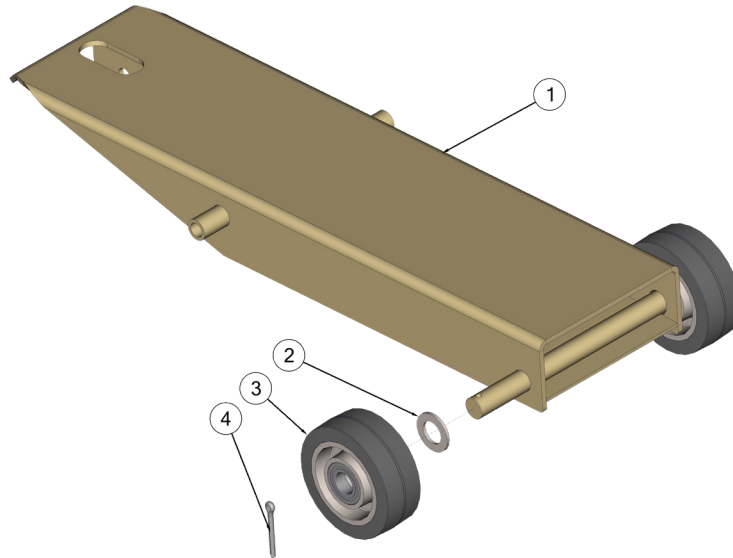

ITEM	PART #	DESCRIPTION	QTY.
1	56302	FORK WELDMENT	1
2	11597	WASHER .755"ID X 1.25"OD X .060"THK	2
3	52001	WHEEL 4 X 1-1/2 X 3/4"BRG. ALUM/RUB	2
4	10306	PIN, COTTER 3/16 X 1-1/2	2

ILLUSTRATION 6: GUIDE BAR ASSEMBLY 300010

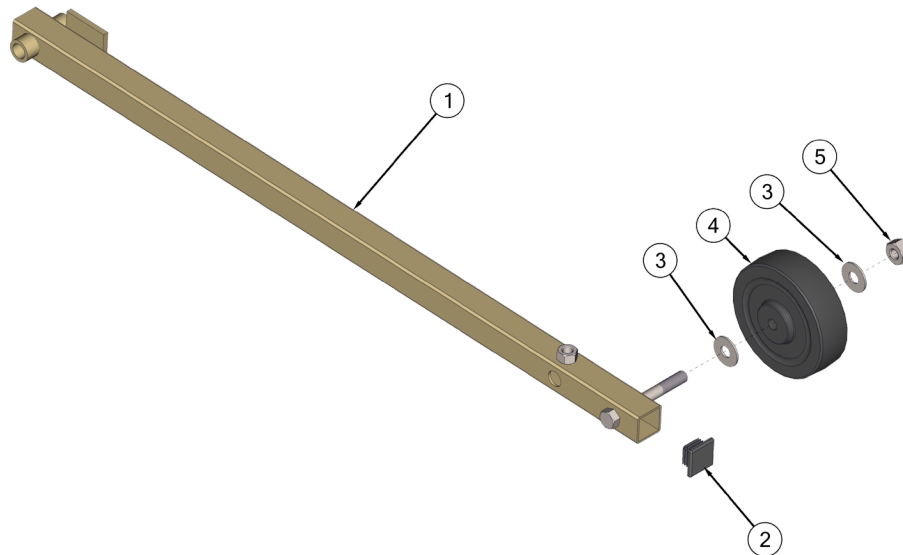

ITEM	PART #	DESCRIPTION	QTY.
1	100130	GUIDE BAR WELDMENT	1
2	51078	PLUG, SQ. TUBE 1 X 14 GA., BLACK	1
3	10025	WASHER, FLAT 3/8 SAE ZINC	2
4	50024	WHEEL 4 X 1-3/8 X 3/8"BORE	1
5	10156	NUT, HEX NYLON LOCK 3/8-16 ZINC	1

ILLUSTRATION 7: BLADE GUARD ASSEMBLY 300013

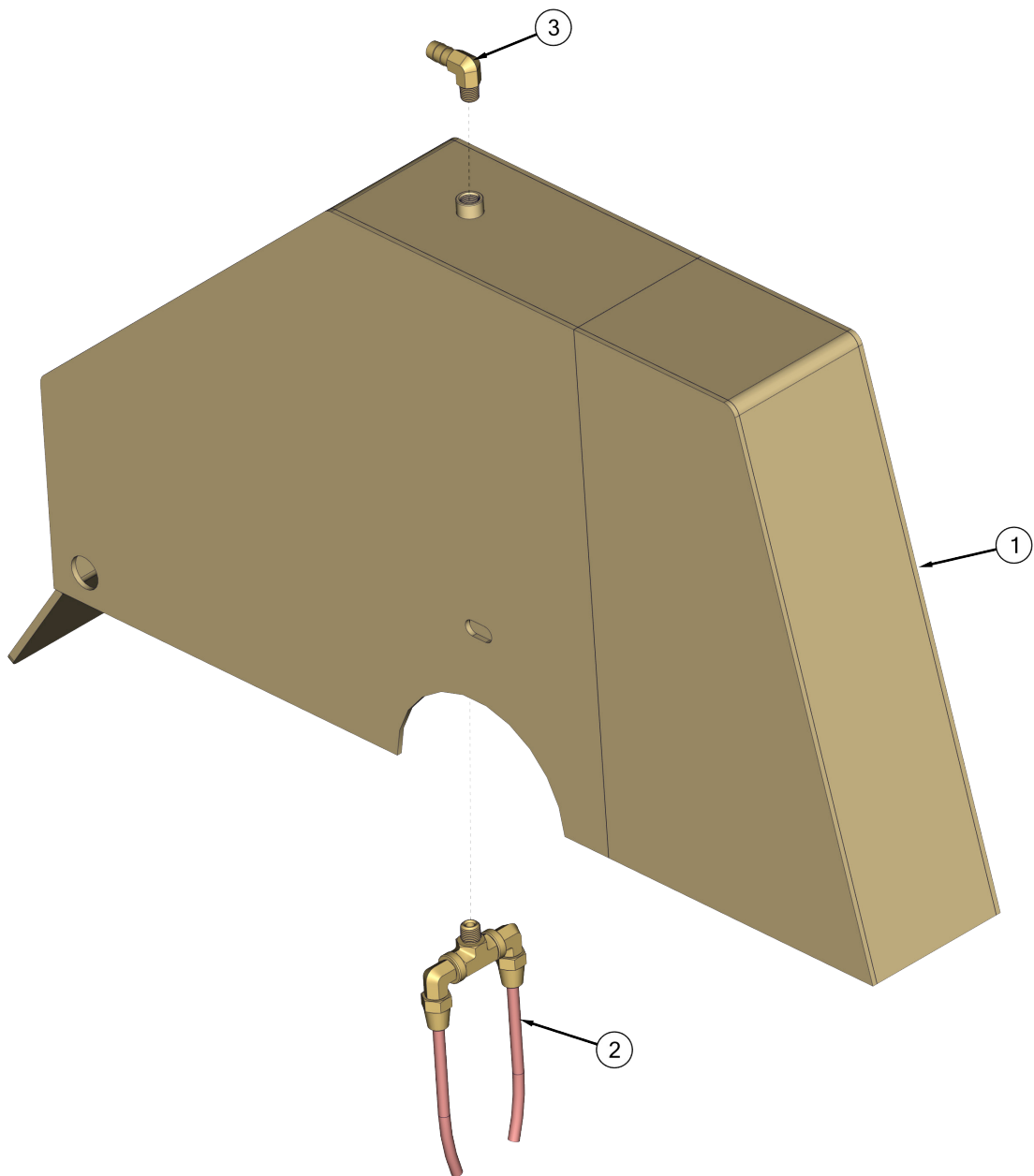

ITEM	PART #	DESCRIPTION	QTY.
1	100209	BLADE GUARD WELDMENT	1
2	81004	WATER NOZZLE 4"	1
3	11562	BARB ELBOW 90, 3/8HOSE X 1/8MPT	1

MODEL DS20-390

ILLUSTRATION 8: ENGINE GROUPING

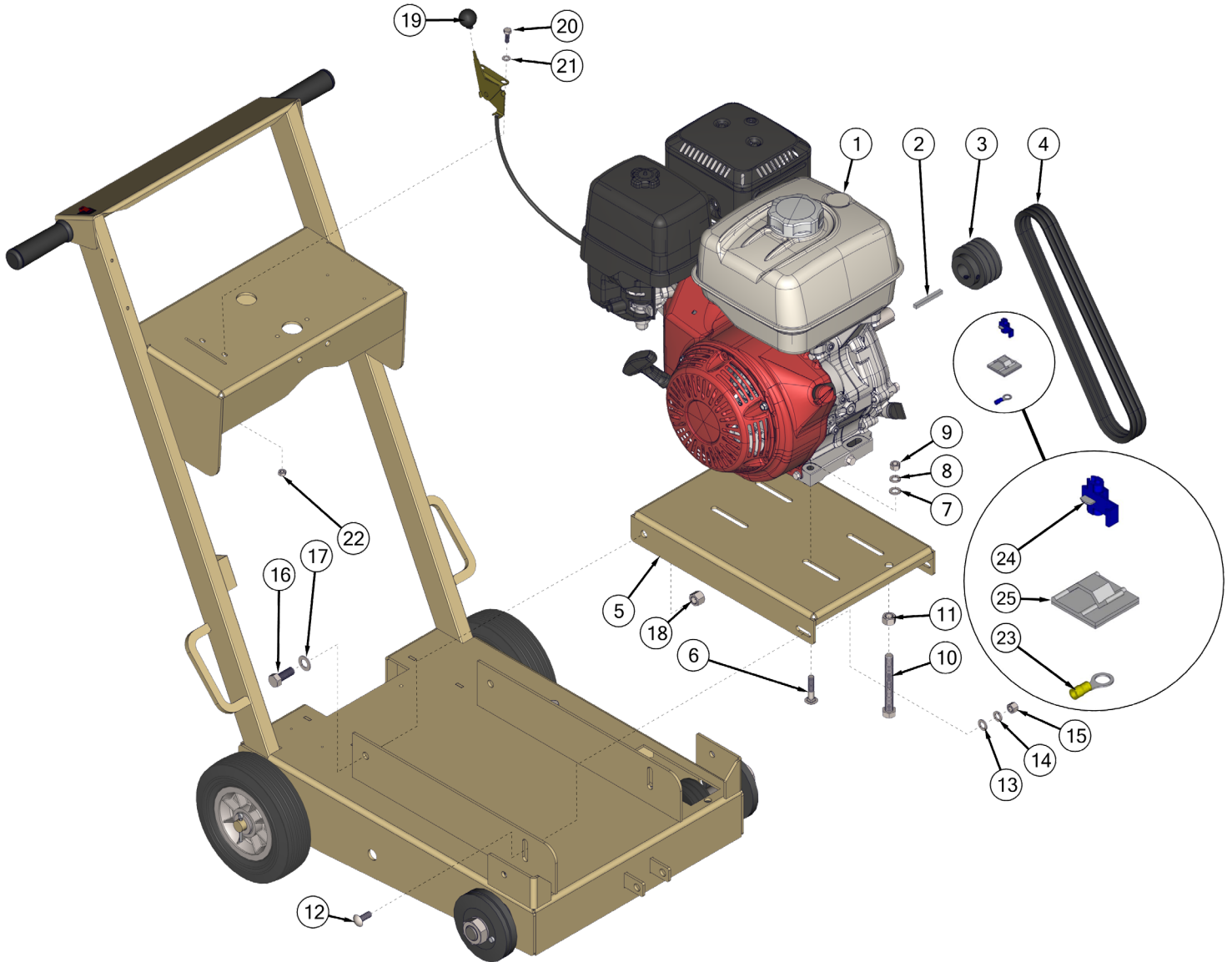

PARTS LISTING - ILLUSTRATION 8: ENGINE GROUPING

ITEM #	PART #	DESCRIPTION	QTY.
1	300011	ENGINE ASSEMBLY (SEE PAGE 14)	1
2	10307	KEY 1/4SQ X 2-1/4	1
3	65238	SHEAVE 2.8"OD X 3GR.3V X 1"BORE	1
4	10201	BELT 3VX-335	3
5	56212	ENGINE MOUNT WELDMENT	1
6	10087	BOLT, CARRIAGE 3/8-16 X 1-3/4	3
	10364	BOLT, CARRIAGE 3/8-16 X 2 GRADE 5	1
7	10025	WASHER, FLAT 3/8 SAE ZINC	4
8	10811	WASHER, LOCK 3/8 ZINC	4
9	10404	NUT, HEX 3/8-16 ZINC	5
10	10392	BOLT, TAP 1/2-13 X 4 (FULL THREAD)	1
11	10417	NUT, HEX 1/2-13 ZINC	1
12	10802	BOLT, CARRIAGE 3/8-16 X 1 ZINC	2
13	10025	WASHER, FLAT 3/8 SAE ZINC	2
14	10811	WASHER, LOCK 3/8 ZINC	2
15	10404	NUT, HEX 3/8-16 ZINC	2
16	10321	SCREW, CAP 1/2-20 X 1-1/4	2
17	10312	WASHER, FLAT 1/2 SAE ZINC	2
18	10154	NUT, HEX NYLON LOCK 1/2-20 ZINC	2
19	100222	LEVER CONTROL, KNOB	1
20	10018	SCREW, CAP 1/4-20 X 3/4	2
21	10602	WASHER, FLAT 1/4 SAE ZINC	2
22	10150	NUT, HEX NYLON LOCK 1/4-20 ZINC	2
23	10976	TERM., RING 3/8 12-10GA. INSULATED NOTE: THIS CONNECTS THE SWITCH GROUNDING WIRE TO THE FRONT LEFT ENGINE MOUNTING BOLT. (ITEM 6, 10364)	1
24	10970	CONN., WIRE QUICK-SPLICE 18-14 GA. NOTE: SPLICE SWITCH WIRE ON HANDLE BAR TO SWITCH WIRE ON ENGINE (SEE PAGE 15)	1
25	36042	CLIP, NATURAL CORD, 1/8" X 1/4" NOTE: THESE ARE ATTACHED TO THE FRAME UNDER THE ENGINE MOUNT TO SECURE THE WIRES.	4

MODEL DS20-390

ILLUSTRATION 9: ENGINE ASSEMBLY 300011

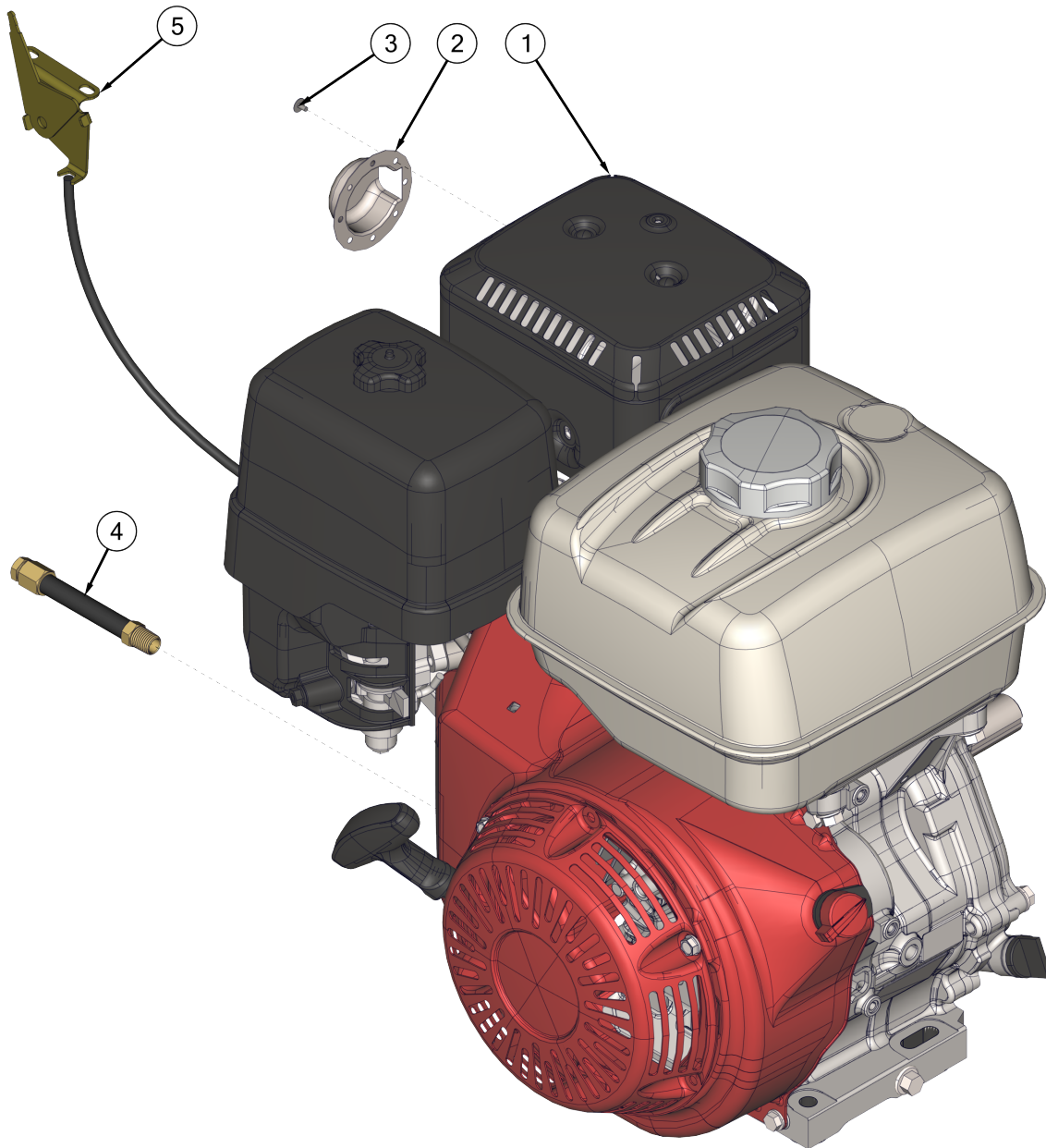

ITEM	PART #	DESCRIPTION	QTY.
1	15029	ENGINE, HONDA GX390UT2QC9 CYC.AC	1
2	10625	MUFFLER CAP, HONDA #18331-ZE3-811	1
3	10128	RIVET, BLIND 1/8 X .275L X .250HD	2
4	56234	OIL DRAIN KIT, M12-1.5 X 7-5/8"	1
5	100221	LEVER CONTROL ASSY., THROTTLE	1

MODEL DS20-390

WIRING DIAGRAM FOR HONDA ENGINE

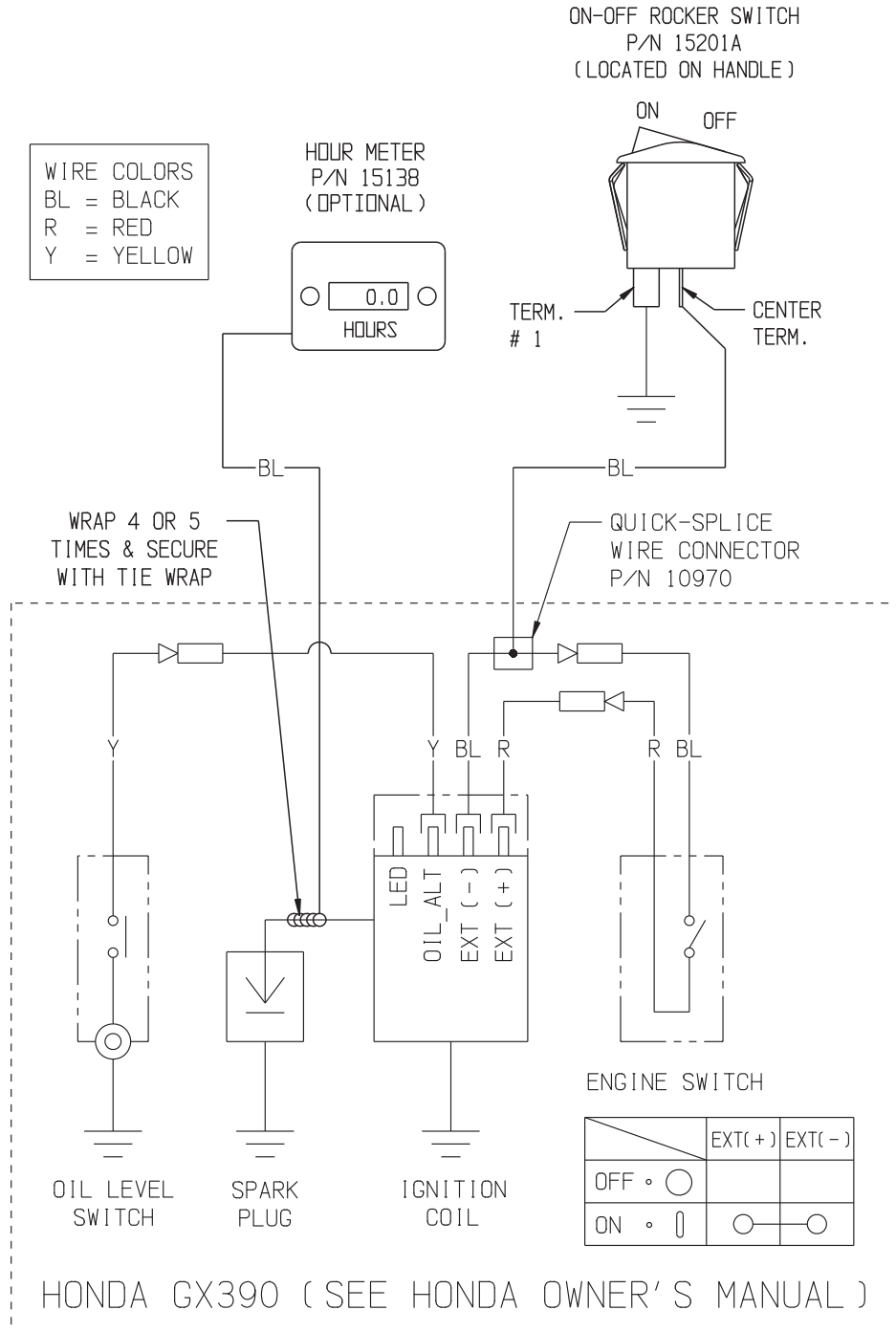

MODELS DS20-7.5B/230/3 & DS20-7.5B/460/3

ILLUSTRATION 10: 7.5HP MOTOR GROUPING

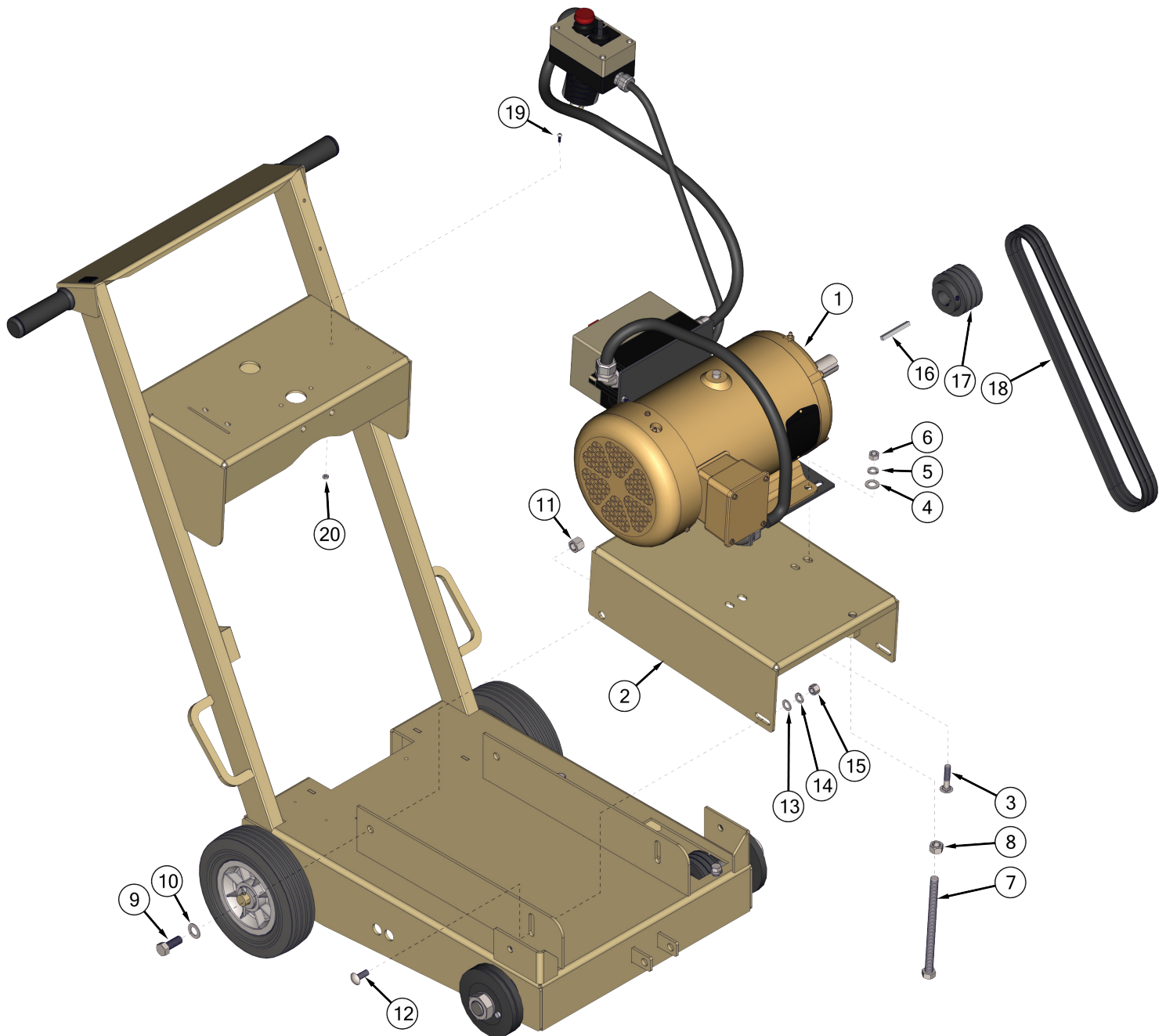

PARTS LISTING - ILLUSTRATION 10: 7.5 HP MOTOR GROUPING			
ITEM #	PART #	DESCRIPTION	QTY.
1	300032 300033	MOTOR ASSEMBLY, DS20-7.5B/230/3 (SEE PAGE 18) MOTOR ASSEMBLY, DS20-7.5B/460/3 (SEE PAGE 18)	1
2	56313	MOTOR MOUNT WELDMENT	1
3	10087	BOLT, CARRIAGE 3/8-16 X 1-3/4	4
4	10025	WASHER, FLAT 3/8 SAE ZINC	4
5	10811	WASHER, LOCK 3/8 ZINC	4
6	10404	NUT, HEX 3/8-16 ZINC	4
7	51067	BOLT, TAP 1/2-13 X 7, GRADE 5	1
8	10417	NUT, HEX 1/2-13 ZINC	1
9	10321	SCREW, CAP 1/2-20 X 1-1/4	2
10	10312	WASHER, FLAT 1/2 SAE ZINC	2
11	10154	NUT, HEX NYLON LOCK 1/2-20 ZINC	2
12	10802	BOLT, CARRIAGE 3/8-16 X 1 ZINC	2
13	10025	WASHER, FLAT 3/8 SAE ZINC	2
14	10811	WASHER, LOCK 3/8 ZINC	2
15	10404	NUT, HEX 3/8-16 ZINC	2
16	100155	KEY 1/4SQ X 2-1/2 (INCLUDED W/ MOTOR)	1
17	56314	SHEAVE 2.8"OD X 3GR.3V X 1-1/8"BORE	1
18	10269	BELT 3VX-400	3
19	11663	SCREW, MACHINE 8-32 X 1/2 RHCD ZINC (LOCATED INSIDE SWITCH BOX)	4
20	10462	NUT, KEPS LOCK 8-32 ZINC	4

MODELS DS20-7.5B/230/3 & DS20-7.5B/460/3

ILLUSTRATION 11: 7.5 HP MOTOR ASSY. 300032 (230V) & 300033 (460V)

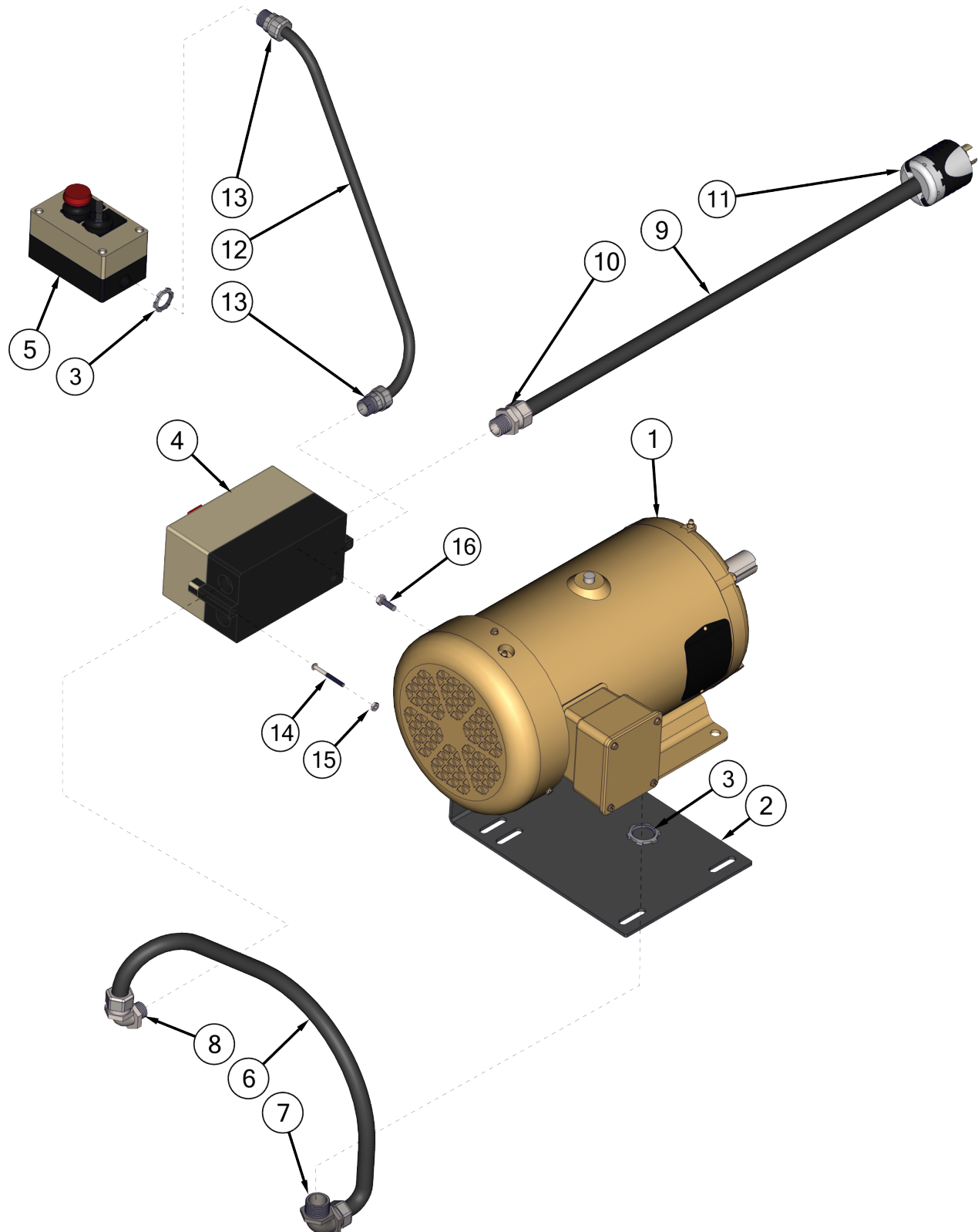

PARTS LISTING - ILLUSTRATION 11: 7.5 HP MOTOR ASSEMBLY			
ITEM #	PART #	DESCRIPTION	QTY.
1	16002	MOTOR, BALDOR 7.5HP-3P 60HZ 3450RPM	1
2	100219	STARTER MOUNT	1
3	10790	CONDUIT LOCK NUT 1/2 NP	2
4	16454	STARTER ACI #128827 RESET ONLY 230V (SEE PAGE 20)	1
	16459	STARTER ACI #128849 RESET ONLY 460V (SEE PAGE 26)	1
5	16660	SWITCH BOX COMPLETE, ON/OFF/E-STOP (SEE PAGE 21)	1
6	100258	CORD 10/4 600V X 35"L, DS20-7.5B	1
7	16539	STRAIN RELIEF 90D X 3/4NPT .50-.625	1
8	11621	STRAIN RELIEF 90D X 1/2NPT .625-.75	1
9	100257	CORD 10/4 600V X 45"L, DS20-7.5B	1
10	41053	STRAIN RELIEF 1/2NPT X .625-.750"	1
11	56323	PLUG, LOCKING 30A/250V L6-30P (230V UNIT)	1
	40037	PLUG, LOCKING 20A/250V L6-20P (460V UNIT)	1
12	100256	CORD 16/2 300V X 35"L, DS20-7.5B	1
13	16190	STRAIN RELIEF 1/2NPT X .250-.350"	2
14	11732	SCREW, MACHINE 10-32 X 1-3/4 RHP	2
15	10832	NUT, KEPS LOCK 10-32 ZINC	3
16	10384	SCREW, MACHINE 10-32 X 1 RHP	1

MODELS DS20-7.5B/230/3 & DS20-7.5B/460/3

**ILLUSTRATION 12: RESET STARTER ASSEMBLY
16454 (230V) & 16459 (460V)**

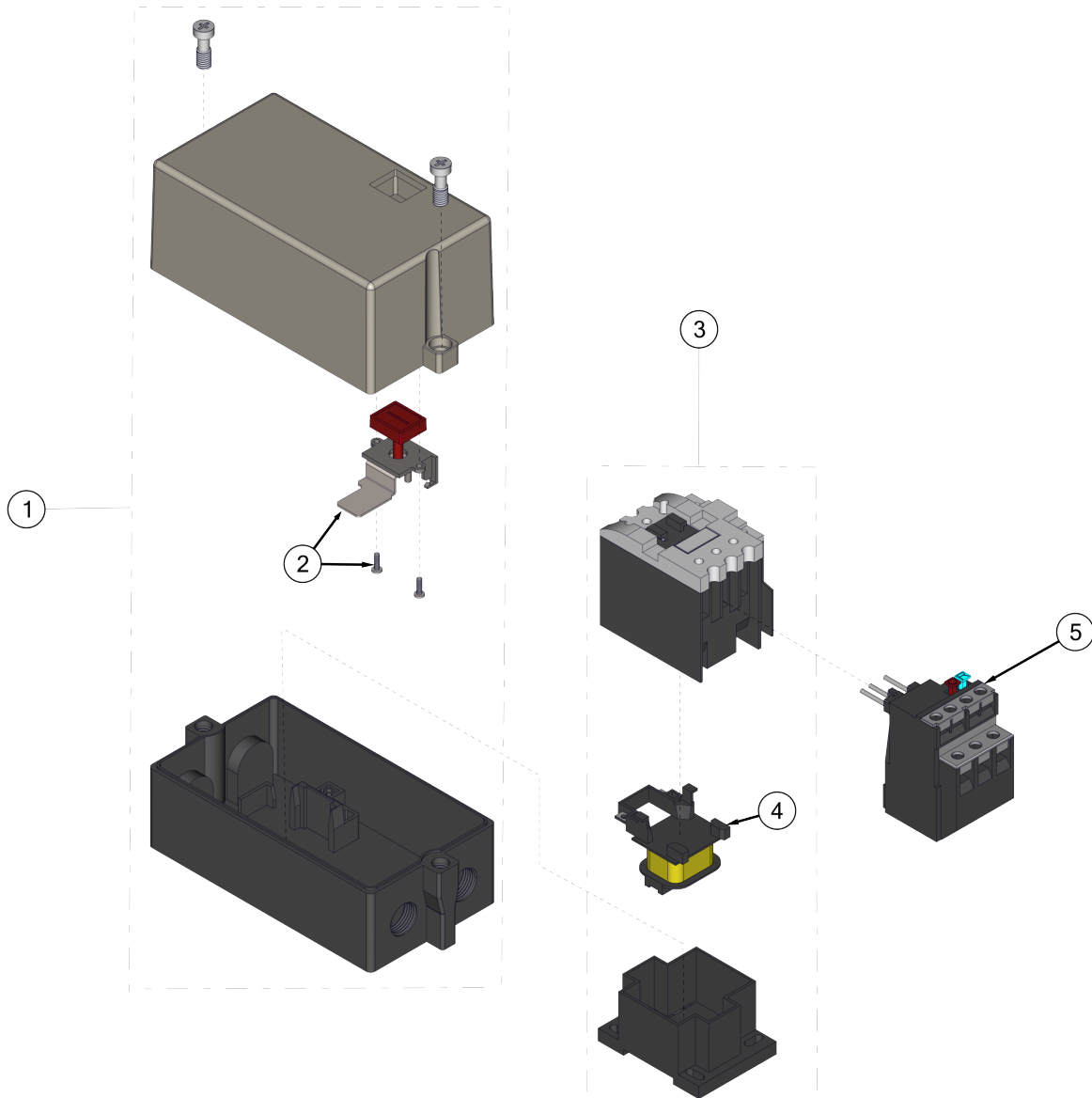

ITEM #	PART #	DESCRIPTION	QTY.
1	16653	STARTER BOX ONLY, RESET	1
2	16655	STOP/RESET PUSHBUTTON ASSY., ACI	1
3	16617 16618	STARTER CONT./COIL ACI SK18.310-230 STARTER CONT./COIL ACI SK18.310-460	1
4	16622 16623	STARTER AC COIL 200/240V-60HZ STARTER AC COIL 440/480V-60HZ	1
5	16633 16637	STARTER OVERLOAD RELAY 7.2-10.0 AMP (460V) STARTER OVERLOAD RELAY 17.5-21.5 AMP (230V)	1 1

MODELS DS20-7.5B/230/3 & DS20-7.5B/460/3

ILLUSTRATION 13: REMOTE SWITCH ASSEMBLY 16660

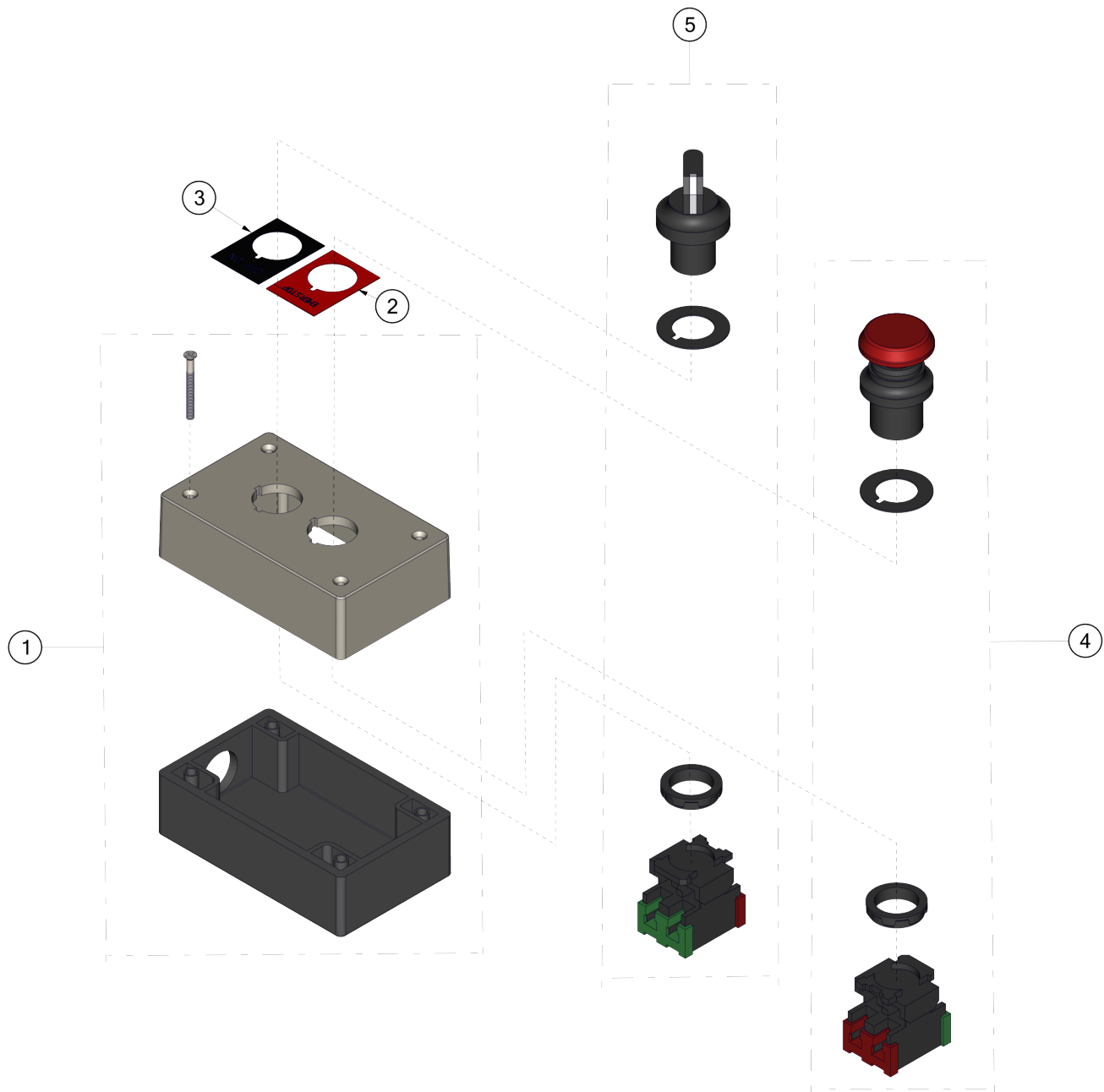

ITEM #	PART #	DESCRIPTION	QTY.
1	16661	ENCLOSURE, 2 HOLE ACI PBE2	1
2	16662	LEGEND PLATE, EMER.STOP	1
3	16663	LEGEND PLATE, OFF/ON	1
4	16664	MUSHROOM BUTTON, RED, 1NO+1NC CONT.	1
5	16665	KNOB TYPE SELECTOR SWITCH, BLACK	1

MODELS DS20-7.5B/230/3 & DS20-7.5B/460/3

WIRING DIAGRAM FOR STARTER & REMOTE SWITCH

60HZ 230/460V 3-PHASE

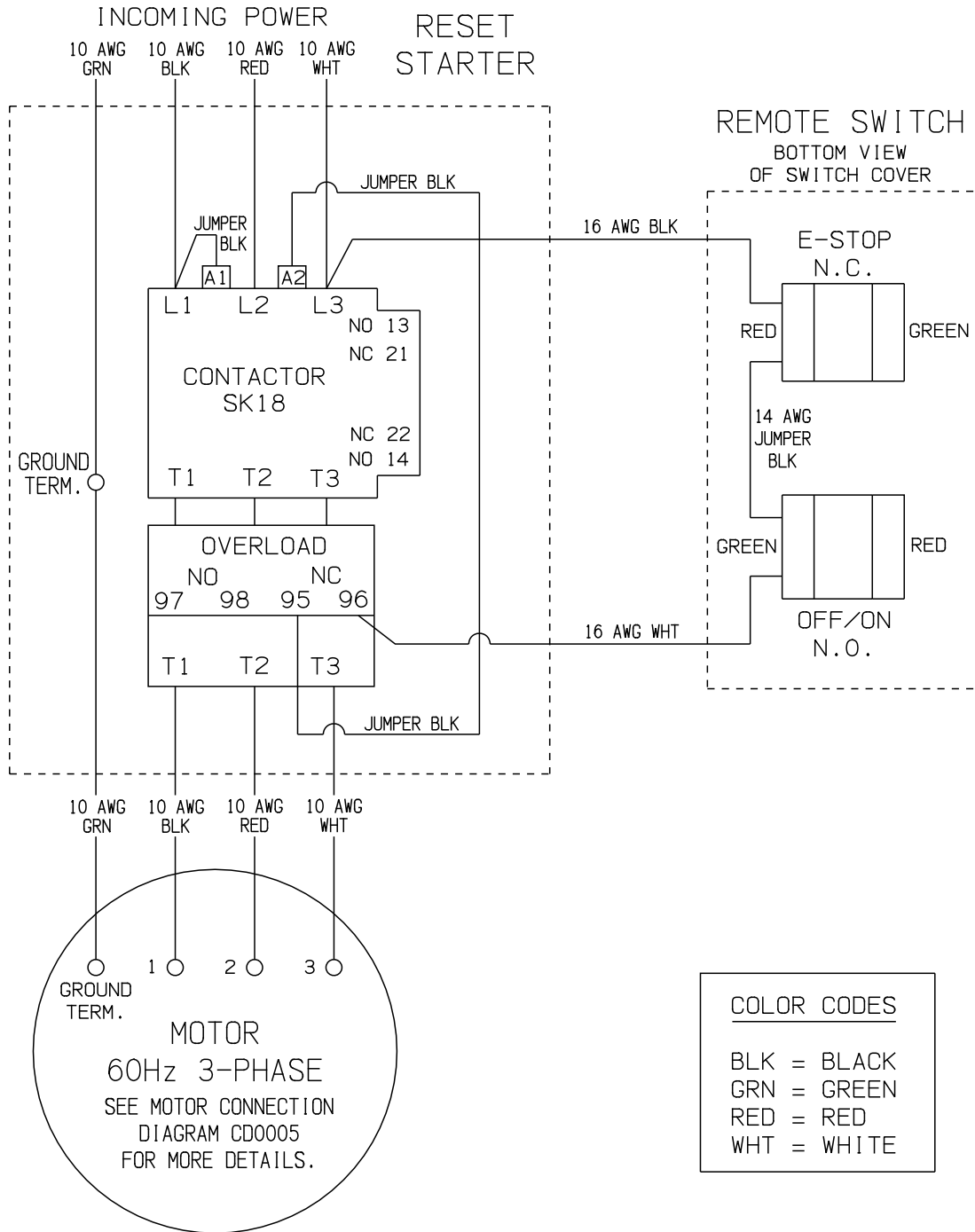

MODELS DS20-7.5B/230/3 & DS20-7.5B/460/3

WIRING DIAGRAM FOR 7.5HP MOTOR

BALDOR CAT. NO. EM3616T

CD0005

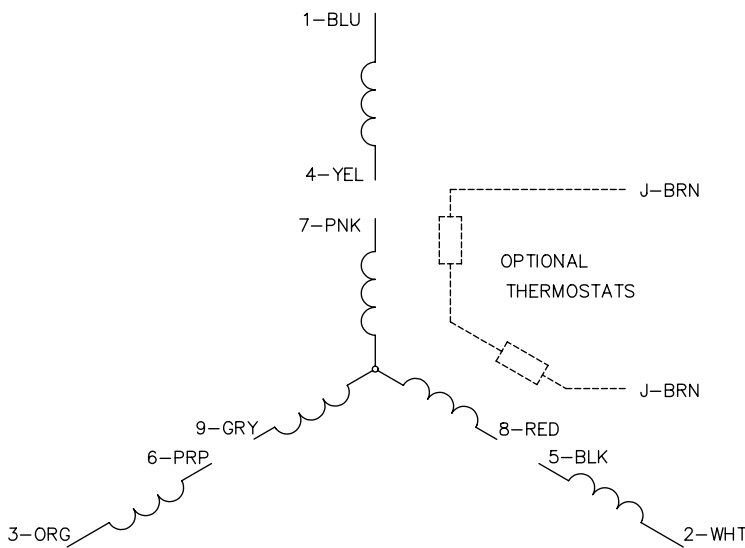

LOW VOLTAGE (2Y)

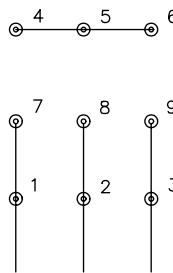

LINE

HIGH VOLTAGE (1Y)

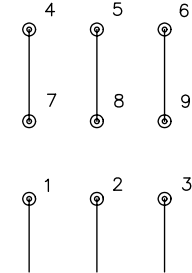

LINE

NOTES:

1. INTERCHANGE ANY TWO LINE LEADS TO REVERSE ROTATION.
2. OPTIONAL THERMOSTATS ARE PROVIDED WHEN SPECIFIED.
3. ACTUAL NUMBER OF INTERNAL PARALLEL CIRCUITS MAY BE A MULTIPLE OF THOSE SHOWN ABOVE.
4. LEAD COLORS ARE OPTIONAL. LEADS MUST ALWAYS BE NUMBERED AS SHOWN.

CD0005

REV. DESC: REVISE TO SHOW OPTIONAL COLORS			
REV. LTR: E	BY: JLP	REVISED: 01/19/99 10:15	TDR: 0171435
CD0005		FILE: AAA00005140	MDL: -
		MTL: -	

BALDOR ELECTRIC Co.

3PH, DV, 9 LEADS

**ILLUSTRATION 14:
OPTIONAL WATER TANK
ASSEMBLY 56310**

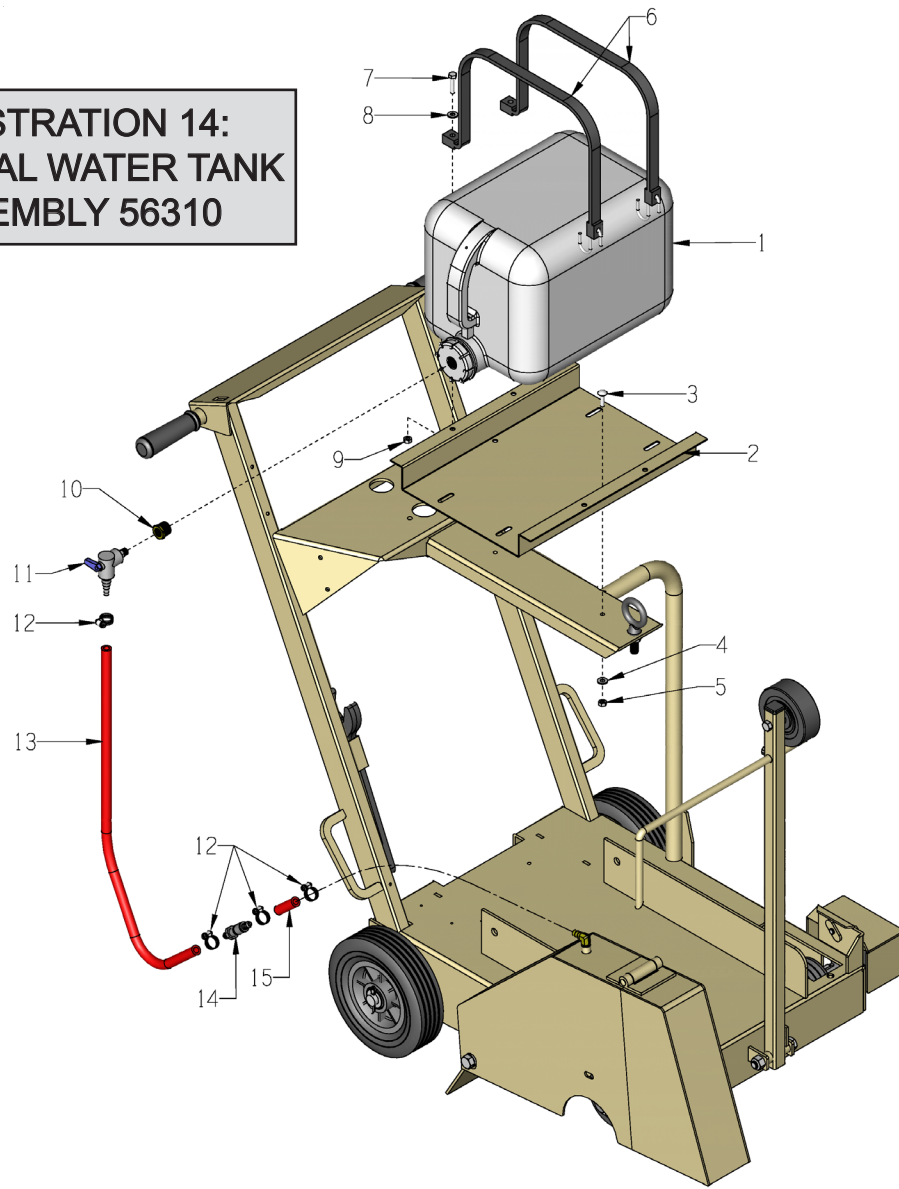

ITEM #	PART #	DESCRIPTION	QTY.
1	52031	DRUM, PLASTIC 5 GALLON, 3/4NPT CAP	1
2	100149	WATER TANK TRAY	1
3	10412	BOLT, CARRIAGE 1/4-20 X 1	2
4	10602	WASHER, FLAT 1/4 SAE ZINC	2
5	10861	NUT, KEPS LOCK 1/4-20 ZINC	2
6	52035	TIE-DOWN STRAP, MOLDED RUBBER 24"	2
7	10905	SCREW, CAP 1/4-20 X 1-1/4	2
8	10602	WASHER, FLAT 1/4 SAE ZINC	2
9	10150	NUT, HEX NYLON LOCK 1/4-20 ZINC	2
10	52034	BUSHING, HEX 3/4 X 1/4 NPT NYLON	1
11	56312	VALVE, BALL PVC 90°A 1/4MPT X BARB	1
12	10714	CLAMP, HOSE, SAE #4, ADJ. TO 5/8"	4
13	56315	HOSE, WATER 3/8"ID X 24"L	1
14	11637	COUPLING, QUICK-DISCONNECT 3/8" (MALE & FEMALE)	1
15	56316	HOSE, WATER 3/8"ID X 2"L	1

DECAL SHEET

P/N 92205 RevF DS-18, DS-20 14 x 17



exceeds 85dBA



WARNING: Cancer and Reproductive Harm. For more information, go to www.P65Warnings.ca.gov

CAUTION
GENERATOR SIZE REQUIREMENT
RATE GENERATOR AT 3 TIMES
MOTOR RATED HORSEPOWER

DANGER
BEFORE CUTTING INTO ANY SURFACE,
INSURE THERE ARE NO BURIED GAS,
ELECTRICAL, HIGH PRESSURE AIR,
SEWER OR WATER LINES

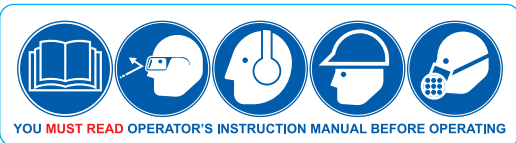

RENTAL-TOUGH

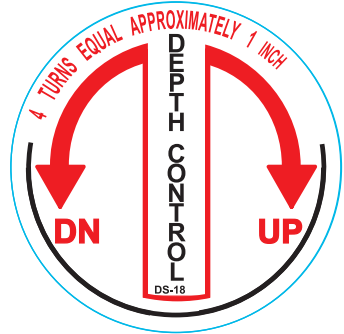

CHECK OIL DAILY

THROTTLE



WARNING
THERE IS NO OIL IN THIS MACHINE

GREASE BEARINGS
DAILY



DECALS CONTINUED

Electric-1 4 x 7
P/N 92206 Rev. A

Vertical text: Voltage Decals 8.5 x 11
P/N 92207

110 VOLTS
220 VOLTS
380 VOLTS
415 VOLTS
440 VOLTS
460 VOLTS
480 VOLTS
575 VOLTS
THREE PHASE
GROUND GROUND
GROUND GROUND

**P/N 91333
DECAL, IMPORTANT NOTE (STARTER)**

IMPORTANT NOTE:
Make sure the ON/OFF power switch is in the **OFF** position before pressing the reset button on starter box. Failure to do so could cause bodily harm and damage to the machine and/or work surface.

LIMITED EQUIPMENT WARRANTY OF SALE

Equipment Development Company, Inc. herein referred to as EDCO (Seller) warrants that each new unit manufactured by EDCO to be free from defects in material and workmanship in normal use and service for a period of (1) one year (except for the cutter drum assembly on all model concrete/asphalt planers AND the chisel head assembly on all model ALR's & ALR-BS in which case the warranty period shall be 90 days) from date of shipment to the original retail or equipment rental center owner.

Accessories or equipment furnished and installed on the product by EDCO but manufactured by others, including, but not limited to engines, motors, electrical components, transmissions etc., shall carry the accessory manufacturers own warranty.

EDCO will, at its option, repair or replace, at the EDCO factory or at a point designated by EDCO, any part which shall appear to the satisfaction of EDCO inspection to have been defective in material or workmanship.

EDCO reserves the right to modify, alter and improve any part or parts without incurring any obligation to replace any part or parts previously sold without such modified, altered or improved part or parts.

This warranty is in lieu of and excludes all other warranties, expressed, implied, statutory, or otherwise created under applicable law including, but not limited to the warranty of merchantability and the warranty of fitness for a particular purpose in no event shall seller or the manufacturer of the product be liable for special, incidental, or consequential damages, including loss of profits, whether or not caused by or resulting from the negligence of seller and/or the manufacturer of the product unless specifically provided herein. In addition, this warranty shall not apply to any products or portions thereof which have been subjected to abuse, misuse, improper installation, maintenance, or operation, electrical failure or abnormal conditions and to products which have been tampered with, altered, modified, repaired, reworked by anyone not approved by seller or used in any manner inconsistent with the provisions of the above or any instructions or specifications provided with or for the product.

TERMS AND CONDITIONS

(NOT APPLICABLE TO SALES THROUGH AUTHORIZED DISTRIBUTION)

FORCE MAJEURE

Seller's obligation hereunder are subject to, and Seller shall not be held responsible for, any delay or failure to make delivery of all or any part of the Product due to labor difficulties, fires, casualties, accidents, acts of the elements, acts of God, transportation difficulties, delays by a common carrier, inability to obtain Product, materials or components or qualified labor sufficient to timely perform part of or all of the obligations contained in these terms and conditions, governmental regulations or actions, strikes, damage to or destruction in whole or part of manufacturing plant, riots, terrorist attacks or incidents, civil commotions, warlike conditions, flood, tidal waves, typhoon, hurricane, earthquake, lightning, explosion or any other causes, contingencies or circumstances within or without the United States not subject to the Seller's control which prevent or hinder the manufacture or delivery of the Products or make the fulfillment of these terms and conditions impracticable. In the event of the occurrence of any of the foregoing, at the option of Seller, Seller shall be excused from the performance under these Terms and Conditions, or the performance of the Seller shall be correspondingly extended.

This document sets forth the terms and conditions pursuant to which the purchaser ("Purchaser") will purchase and Equipment Development Co. Inc. ("Seller") will sell the products, accessories, attachments (collectively the Products) ordered by the Purchaser. These terms and conditions shall govern and apply to the sale of Seller's Products to Purchaser, regardless of any terms and conditions appearing on any purchase order or other forms submitted by Purchaser to Seller, or the inconsistency of any terms therein and herein.

1. PRICE

All prices set forth on any purchase order or other document are F.O.B. Seller's facility or distribution point, as may be determined by Seller (F.O.B. Point). All prices are exclusive of any and all taxes, including, but not limited to, excise, sales, use, property or transportation taxes related to the sale or use of the Products, now or hereafter imposed, together with all penalties and expenses. Purchaser shall be responsible for collecting and/or paying any and all such taxes, whether or not they are stated in any invoice for the Products. Unless otherwise specified herein, all prices are exclusive of inland transportation, freight, insurance and other costs and expenses relating to the shipment of the Products from the F.O.B. point to Purchaser's facility. Any prepayment by Seller of freight insurance and other costs shall be for the account of Purchaser and shall be repaid to Seller.

2. PAYMENT TERMS

Payment terms are as follows. 2% 10 days (to approved and qualified accounts). Net 30 days. This is a cash discount for invoices paid within 10 days after the invoice date, regardless of date of receipt of shipment. This is not a trade discount and will not be granted to accounts that do not adhere to stated terms.

*All past due accounts are subject to a late payment fee of 1.5% per month or a maximum allowed by law if different, along with the expenses incidental to collection including reasonable attorney's fees and costs.

*Seller reserves the right to hold shipments against past due accounts.

*Seller reserves the right to alter payment terms.

3. FREIGHT TERMS

All shipments will be made F.O.B. shipping point as designated in these Terms and Conditions, and title shall pass at the F.O.B. point. Delivery to the initial common carrier shall constitute delivery to the Purchaser. Any claims for loss or damage during shipment are to be filed with carrier by the Purchaser. Seller will not assume responsibility for the performance of the carrier.

Back orders will be shipped in the most practical fashion with charges consistent with our freight policy established with the original order. UPS, FED EX, MAIL or shipments by other couriers are subject to the same terms and conditions as outlined in paragraph #3 "Freight Terms".

4. DELIVERY, DAMAGES, SHORTAGES

Seller shall use reasonable efforts to attempt to cause the Products to be delivered as provided for in these Terms & Conditions. Delivery to the initial common carrier shall constitute the delivery to the Purchaser. Seller's responsibility, in so far as transportation risks are concerned ceases upon the delivery of the Products in good condition to such carrier at the F.O.B. point and all the Products shall be shipped at the Purchaser's risk. Seller shall not be responsible or liable for any loss of income and/or profits, or incidental, special, consequential damages resulting from Seller's delayed performance in shipment and delivery.

5. RETURN OF DEFECTIVE PRODUCTS

Defective or failed material shall be held at the Purchaser's premises until authorization has been granted by Seller to return or dispose of Products. Products that are to be returned for final inspection must be returned Freight Prepaid in the most economical way. Credit will be issued for material found to be defective upon Seller's inspection based on prices at time of purchase.

6. PRODUCTS ORDERED IN ERROR

Products may be returned, provided that claim is made and Seller is notified within 7 days of receipt of Products, and the Products are in original buyer's possession not more than 30 days prior to return, subject to Seller's approval. If Products are accepted for return, they must be Freight Prepaid and buyer will be charged a minimum of 15% restocking charge, plus a charge back for outbound freight charges if the original order was shipped prepaid. Returns are not accepted for any Products that are specifically manufactured to meet the buyer's requirement of either specifications or quantity.

AGREEMENTS

These Terms and Conditions constitute the entire agreement between Seller and Purchaser as it relates to terms and conditions of sale, and supersedes any and all prior oral or written agreements, correspondence, quotations or understandings heretofore in force between the parties relating to the subject matter hereof. There are no agreements between Seller and Purchaser with respect to the Product herein except those specifically set forth in and made part of these terms and conditions. Any additional terms, conditions and/or prices are rejected by Seller.

These terms and conditions may be modified, cancelled or rescinded only by a written agreement of both parties executed by their duly authorized agents.

USE ONLY GENUINE EDCO PARTS & ACCESSORIES

For your own safety, the safety of others and the life of your machine.

SUBMIT ALL WARRANTY CLAIMS AT:

edcoinc.com/customer-support/warranty-claim-form/



BEFORE USING THIS PRODUCT

Have You Used EDCO's Online Customer Support??



Scan This QRC or Visit
www.edcoinc.com/customer-support



READ: **EDCO Owner's Manuals and Parts Listings** share basic information and parts of each product. Download and print them whenever needed.



WATCH: **EDCO Product Training Videos** show how to use products, install tooling, and perform basic maintenance.



Example Only

FIND: Somewhere on this product is an **EDCO QRC Training Decal**. Scanning this code provides owner's information, videos, and other training content anywhere/anytime on your mobile device.



CONCRETE KNOWLEDGE

JOIN: **EDCOed.com** is a free, 24-hour training space. Each certification track focuses on a specific EDCO product group. The information in these tracks help businesses be successful with those products.

EDCO is always updating online training / information so you always have the most recent content.

Also see Operator's Safety & Limited Warranty Manual

Equipment Development Co., Inc. • 800.638.3326 • techsupport@edcoinc.com