

REVISED STARTING
SERIAL # 110610001

PARTS LIST MANUAL

MODEL CPM10



GASOLINE MODEL SHOWN

10" WALK BEHIND SCARIFIERS

SKU #	MODEL #	POWER OPTION
69100	CPM10-13H	HONDA GASOLINE ENGINE MODEL GX390
69200-230	CPM10-7.5B/230/3	BALDOR ELECTRIC MOTOR 7.5HP 60Hz 3PH 230V
69200-460	CPM10-7.5B/460/3	BALDOR ELECTRIC MOTOR 7.5HP 60Hz 3PH 460V



A Division of Equipment Development Company, Inc.

100 Thomas Johnson Drive, Frederick, MD 21702-4600 USA
 Phone (301) 663-1600 • 1-800-638-3326
 Fax (301) 663-1607 • 1-800-447-3326
 Website: www.edcoinc.com
 Email: sales@edcoinc.com

Printed in USA

JWA ©2011

READ AND UNDERSTAND THE OPERATORS INSTRUCTION MANUAL *THOROUGHLY* BEFORE ATTEMPTING TO OPERATE THIS EQUIPMENT.



Death or serious injury could occur if this machine is used improperly.



SAFETY MESSAGES

- Safety Instructions are preceded by a graphic alert symbol of DANGER, WARNING, or CAUTION.



Indicates an imminent hazard which, if not avoided, will result in death or serious injury.



Indicates an imminent hazard which, if not avoided, can result in death or serious injury.



Indicates hazards which, if not avoided, could result in serious injury and or damage to the equipment.

GASOLINE/PROPANE POWERED EQUIPMENT



- Engine exhaust from this product contains chemicals known to the State of California to cause cancer, birth defects or other reproductive harm.



- Gasoline is extremely flammable and poisonous. It should only be dispensed in well ventilated areas, and with a cool engine.

- Small gasoline engines produce high concentrations of carbon monoxide (CO) example: a 5 HP 4 cycle engine operation in an enclosed 100,000 cu. ft. area with only one change of air per hour is capable of providing deadly concentrations of CO in less than fifteen minutes. Five changes of air in the same area will produce noxious fumes in less than 30 minutes. Gasoline or propane powered equipment should not be used in enclosed or partially enclosed areas. Symptoms of CO poisoning include, headache, nausea, weakness, dizziness, visual problems and loss of consciousness. If symptoms occur - get into fresh air and seek medical attention immediately.

ELECTRICAL POWERED EQUIPMENT



Extreme care must be taken when operating electric models with water present: Ensure power cord is properly grounded, is attached to a Ground-Fault-Interrupter (GFI) outlet, and is undamaged.

- Check all electrical cables - be sure connections are tight and cable is continuous and in good condition. Be sure cable is correctly rated for both the operating current and voltage of this equipment.
- Improper connection of the equipment-grounding conductor can result in a risk of electric shock. Check with qualified electrician or service person if there is any doubt as to whether the outlet is properly grounded. Adhere to **all** local codes and ordinances.
- **NOTE:** In the event of a malfunction or breakdown, grounding provides a path of least resistance for the electric current to dissipate. The motor is equipped with a grounded plug and must be connected to an outlet that is properly installed and properly grounded. DO NOT modify the plug provided on the motor. If the plug does not fit the outlet have a qualified electrician install the proper receptacle.
- Switch motor OFF **before** disconnecting power.

- Do not disconnect power by pulling cord. To disconnect, grasp the plug, not the cord.
- Unplug power cord at the machine when not in use and before servicing.

GENERAL INSTRUCTIONS

- Equipment should only be operated by trained personnel in good physical condition and mental health (not fatigued). The operator and maintenance personnel must be physically able to handle the bulk weight and power of this equipment.
- This is a one person tool. Maintain a safe operating distance to other personnel. It is the **operators' responsibility** to keep other people (workers, pedestrians, bystanders, etc.) away during operation. Block off the work area in all directions with roping, safety netting, etc. for a safe distance. Failure to do so may result in others being injured by flying debris or exposing them to harmful dust and noise.
- This equipment is intended for commercial use only.
- For the operator's safety and the safety of others, always keep all guards in place during operation.
- Never let equipment run unattended.



- Personal Protection Equipment and proper safety attire must be worn when operating this machinery. The operator must wear approved safety equipment appropriate for the job such as hard hat and safety shoes when conditions require. Hearing protection **MUST** be used (operational noise levels of this equipment may exceed 85db). Eye protection **MUST** be worn at all times.



- Keep body parts and loose clothing away from moving parts. Failure to do so could result in dismemberment or death.

- Do not modify the machine.
- Stop motor/engine when adjusting or servicing this equipment.
-  Maintain a safe operating distance from flammable materials. Sparks from the cutting-action of this machine can ignite flammable materials or vapors.

DUST WARNING



Some dust created by power sanding, sawing, grinding, drilling, and other construction activities contains chemicals known to cause cancer, birth defects, or other reproductive harm. Some examples of these chemicals are:

- Lead from lead-based paints, and
 - Crystalline silica from bricks and concrete and other masonry products.
- Your risk of exposure to these chemicals varies depending on how often you do this type of work. To reduce your risk: work in a well ventilated area, use a dust control system, such as an industrial-style vacuum, and wear approved personal safety equipment, such as a dust/particle respirator designed to filter out microscopic particles.

PARTS LIST MANUAL

MODEL CPM10

10" WALK BEHIND SCARIFIER

TABLE OF CONTENTS

<u>Section</u>	<u>Page Number</u>
Safety Messages and General Instructions	2
How To Order Replacement Parts	3
Illustration 1: Main Grouping	4, 5
Illustration 2: Rear Fork & Control Linkage Grouping	6, 7
Illustration 3: Water System Kit (Optional)	8
Illustration 4: Rubber Seal Grouping	9
Illustration 5: Drum Shaft & Bearing Grouping	10, 11
Illustration 6: 6-Shaft Cutter Drum Assembly (Standard)	12
Illustration 7: 8-Shaft Cutter Drum Assembly (Optional)	13
Illustration 8: Engine Grouping	14, 15
Illustration 9: 60Hz Motor Grouping	16, 17
Wiring Diagram for Starter & Remote Switch	18
Wiring Diagram for 60Hz Motor	19
Limited Equipment Warranty of Sale - Terms & Conditions	20 (Back Page)

<p style="text-align: center;">HOW TO ORDER REPLACEMENT PARTS</p> <ul style="list-style-type: none"> ❑ To insure product safety and reliability, always use genuine EDCO replacement parts when making repairs to the equipment. ❑ When calling for parts, specify the MODEL and SERIAL number of the machine, which can be found on the NAME PLATE. Keep that information in the space provided. In addition to this information, give part number, description, and quantity as listed on the parts list to your parts representative. ❑ Please note: Due to improvements and changes in the equipment, the illustrations shown may be different than the actual machine. 	<p style="text-align: center;">FILL IN INFORMATION BELOW</p> <p>Date of Purchase _____</p> <p>Model # _____</p> <p>Serial # _____</p> <p>SKU # _____</p>
---	---



100 Thomas Johnson Drive, Frederick, MD 21702-4600 USA
 Phone (301) 663-1600 • 1-800-638-3326
 Fax (301) 663-1607 • 1-800-447-3326
 Website: www.edcoinc.com
 Email: sales@edcoinc.com

ILLUSTRATION 1 : MAIN GROUPING

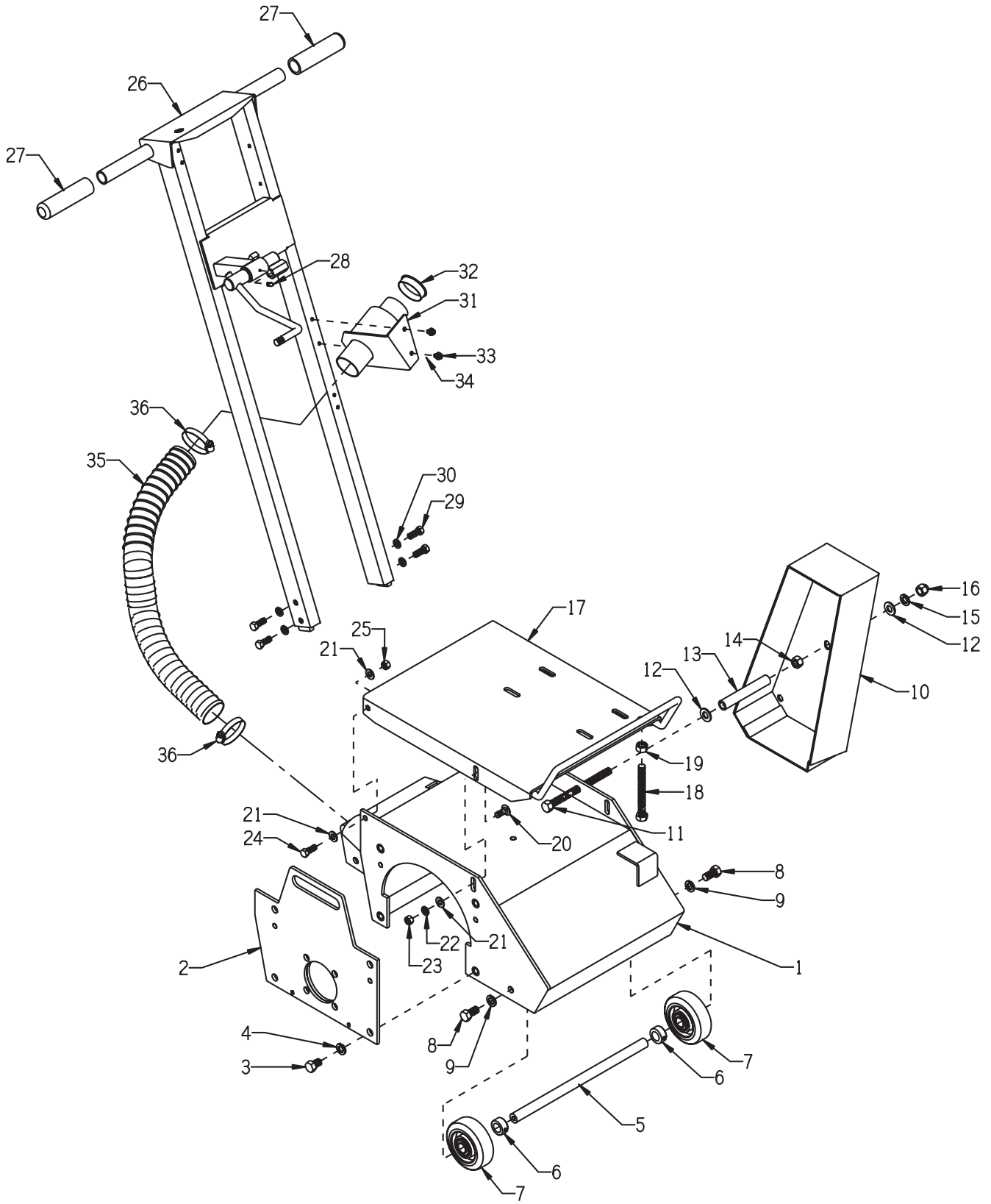

PARTS LISTING - ILLUSTRATION 1: MAIN GROUPING			
ITEM #	PART #	DESCRIPTION	QTY.
1	65201	MAIN FRAME, CPM-10	1
2	65202	PANEL, DRUM SIDE ACCESS, CPM-10	1
3	11614	SCREW, CAP 1/2-20 X 3/4	4
4	10045	WASHER, LOCK 1/2 ZINC	4
5	65207	AXLE SHAFT, FRONT, CPM-10, 3/4"DIA. x 13-15/16"L	1
6	10428	COLLAR, LOCKING 3/4"ID	2
7	52001	WHEEL 4 X 1-1/2 X 3/4"BRG.	2
8	10304	SCREW, CAP 1/2-20 X 1	2
9	10045	WASHER, LOCK 1/2 ZINC	2
10	65205	COVER, BELT, CPM-10	1
11	65240	BOLT, ALLTHREAD ROD 1/2-13 X 6-3/8	2
12	10312	WASHER, FLAT 1/2 SAE ZINC	4
13	65206	SPACER, BELT COVER, 1/2"ID x 3/4"OD x 4-3/4"L	2
14	10417	NUT 1/2-13	2
15	10045	WASHER, LOCK 1/2 ZINC	2
16	10865	NUT, ACORN 1/2-13	2
17	65203	MOUNT, ENGINE, CPM-10 (SHOWN)	1
	65204	MOUNT, MOTOR, CPM-10	1
18	10345	BOLT, TAP 1/2-13 X 4-1/2 (FULL THD)	1
19	10417	NUT 1/2-13	1
20	10802	BOLT, CARRIAGE 3/8-16 X 1 FULL THD.	2
21	10025	WASHER, FLAT 3/8 SAE ZINC	6
22	10811	WASHER, LOCK 3/8 ZINC	2
23	10404	NUT 3/8-16	2
24	10021	SCREW, CAP 3/8-24 X 1	2
25	10004	NUT, LOCK 3/8-24	2
26	65210	HANDLE BAR, CPM-10	1
27	10608	GRIP, HAND .937 X 4.5 BLK VYNAFOAM	2
28	10808	FITTING, GREASE 1/4-28 STRAIGHT	1
29	10055	SCREW, CAP 3/8-16 X 1	4
30	10811	WASHER, LOCK 3/8 ZINC	4
31	86347	BRACKET, MULTI-VAC PORT 2-3"	1
32	65021	CAP/PLUG 2" RED PLASTIC, FLANGED	1
33	10846	SCREW, CAP STSHW 1/4-20 X 1/2	2
34	10038	WASHER, LOCK 1/4 ZINC	2
35	65098	HOSE, FLEX 2"ID X 22"L	1
36	10766	CLAMP, HOSE, SAE #32, ADJ. TO 2-1/2	2

ILLUSTRATION 2: REAR FORK & CONTROL LINKAGE GROUPING

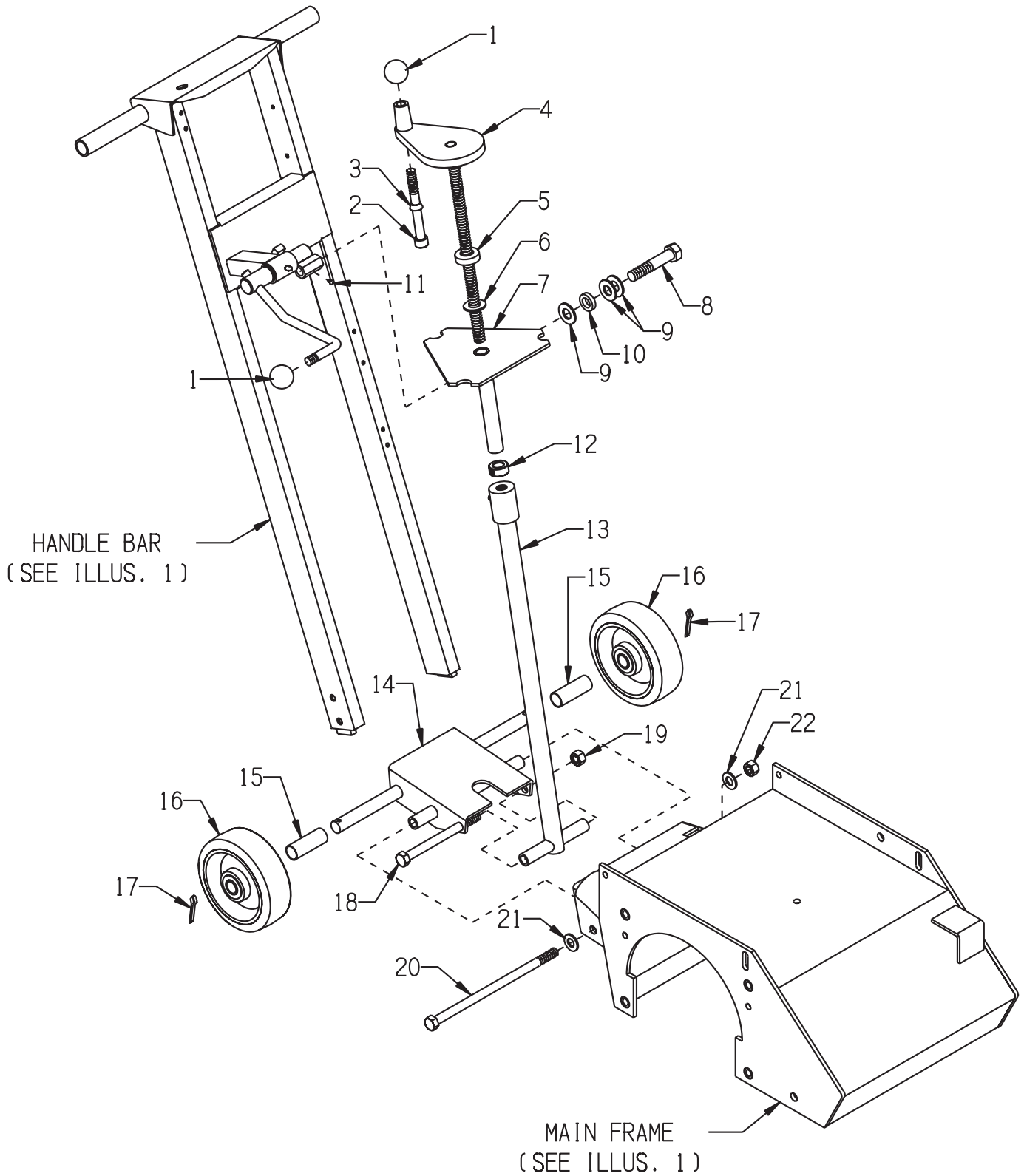

PARTS LISTING - ILLUSTRATION 2: REAR FORK & CONTROL LINKAGE GROUPING			
ITEM #	PART #	DESCRIPTION	QTY.
1	14023	KNOB, BALL 1-3/8 W/ 1/2-13THD, BLK.	2
2	10346	SCREW, SKT. HD. CAP 1/2-13 X 4-1/2	1
3	50550	SLEEVE, BRASS 1/2" TAPERED	1
4	51075	HANDWHEEL, LARGE W/ 5/8-8 X 13"ROD	1
5	85005	BEARING, THRUST BALL 5/8"ID X 1-7/16"OD X 7/16"THK	1
6	10073	WASHER, FLAT 5/8 SAE ZINC	1
7	65214	LINKAGE SUPPORT, HANDWHEEL, CPM-10	1
8	10359	SCREW, CAP 5/8-11 X 3-1/4	1
9	10073	WASHER, FLAT 5/8 SAE ZINC	3
10	79035	BUSHING, RUB. 1-1/16"OD X 5/8"ID X 1/4"THK	1
11	10127	SCREW, DRIVE 1/8 X 1/4"L	1
12	10096	COLLAR, LOCKING 5/8"ID	1
13	65242	LINKAGE, LOWER, CPM-10	1
14	65208	FORK, CPM-10	1
15	65209	SPACER 2-1/2"L , REAR WHEEL, CPM-10	2
16	50030	WHEEL 6 X 2 X 3/4"BRG.,ALUM./RUBBER	2
17	10306	PIN, COTTER 3/16 X 1-1/2	2
18	10329	SCREW, CAP 1/2-20 X 6	1
19	10205	NUT, LOCK 1/2-20	1
20	65239	SCREW, CAP 1/2-13 X 10	1
21	10312	WASHER, FLAT 1/2 SAE ZINC	2
22	10407	NUT, LOCK 1/2-13	2

**ILLUSTRATION 3: WATER SYSTEM KIT
PART # 65080**

OPTIONAL

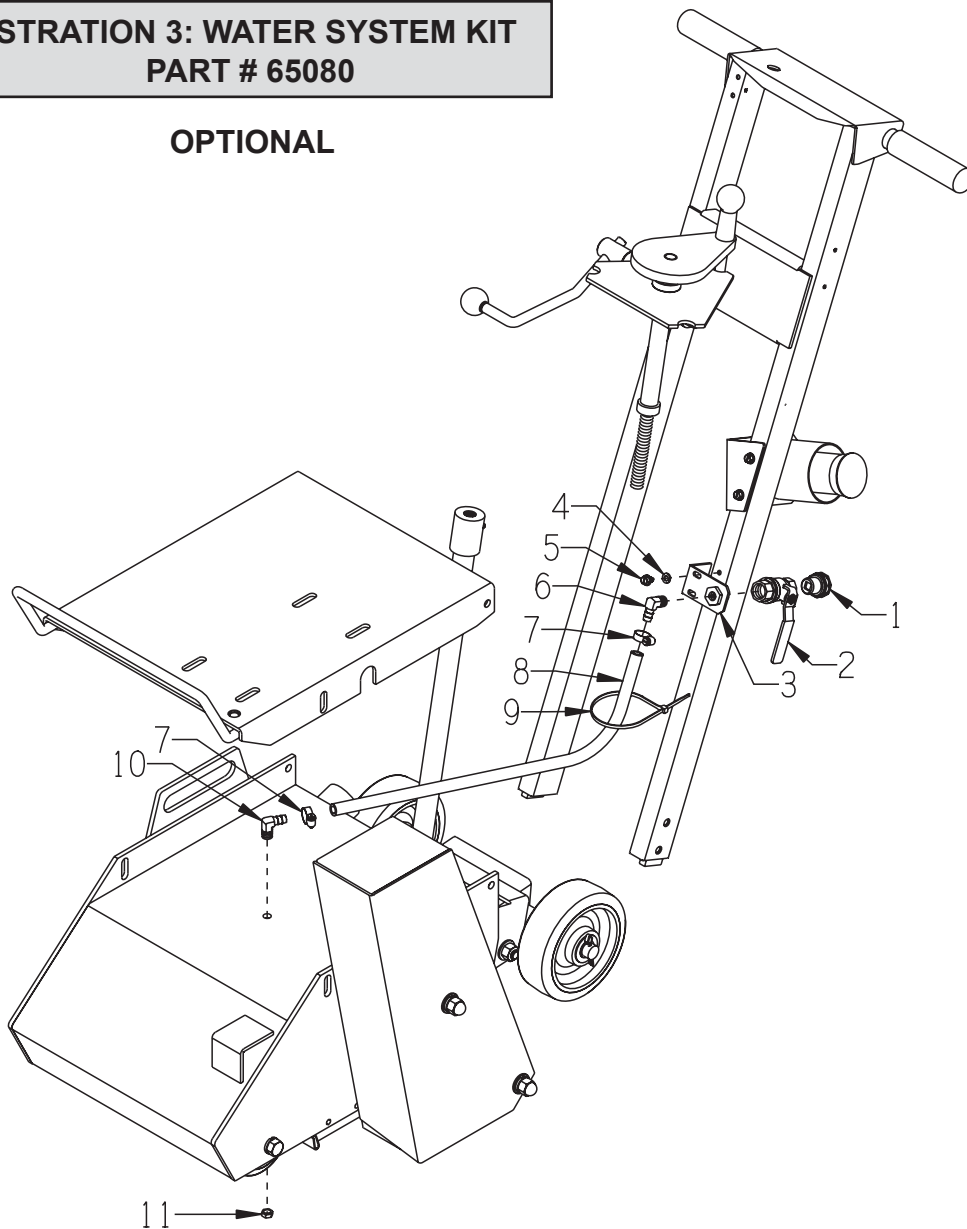

ITEM #	PART #	DESCRIPTION	QTY.
1	80021	CONN., SWIVEL FEM. 3/4HOSE X 1/2MPT	1
2	10711	VALVE, BALL 1/2 FPT	1
3	56022	BRACKET, WATER VALVE	1
4	10038	WASHER, LOCK 1/4 ZINC	2
5	10846	SCREW, CAP STSHW 1/4-20 X 1/2	2
6	10799	BARB ELBOW 90, 3/8HOSE X 1/4MPT (BRASS)	1
7	50069	CLAMP, HOSE, SAE #6, ADJ. TO 13/16	2
8	65081	HOSE, WATER 3/8"ID X 24"L	1
9	10982	TIE, CABLE, BLACK NYLON 11-1/4"	1
10	11562	BARB ELBOW 90, 3/8HOSE X 1/8MPT (BRASS)	1
11	10864	NUT 1/8-27 PIPE THREAD (BRASS)	1

ILLUSTRATION 4: RUBBER SEAL GROUPING

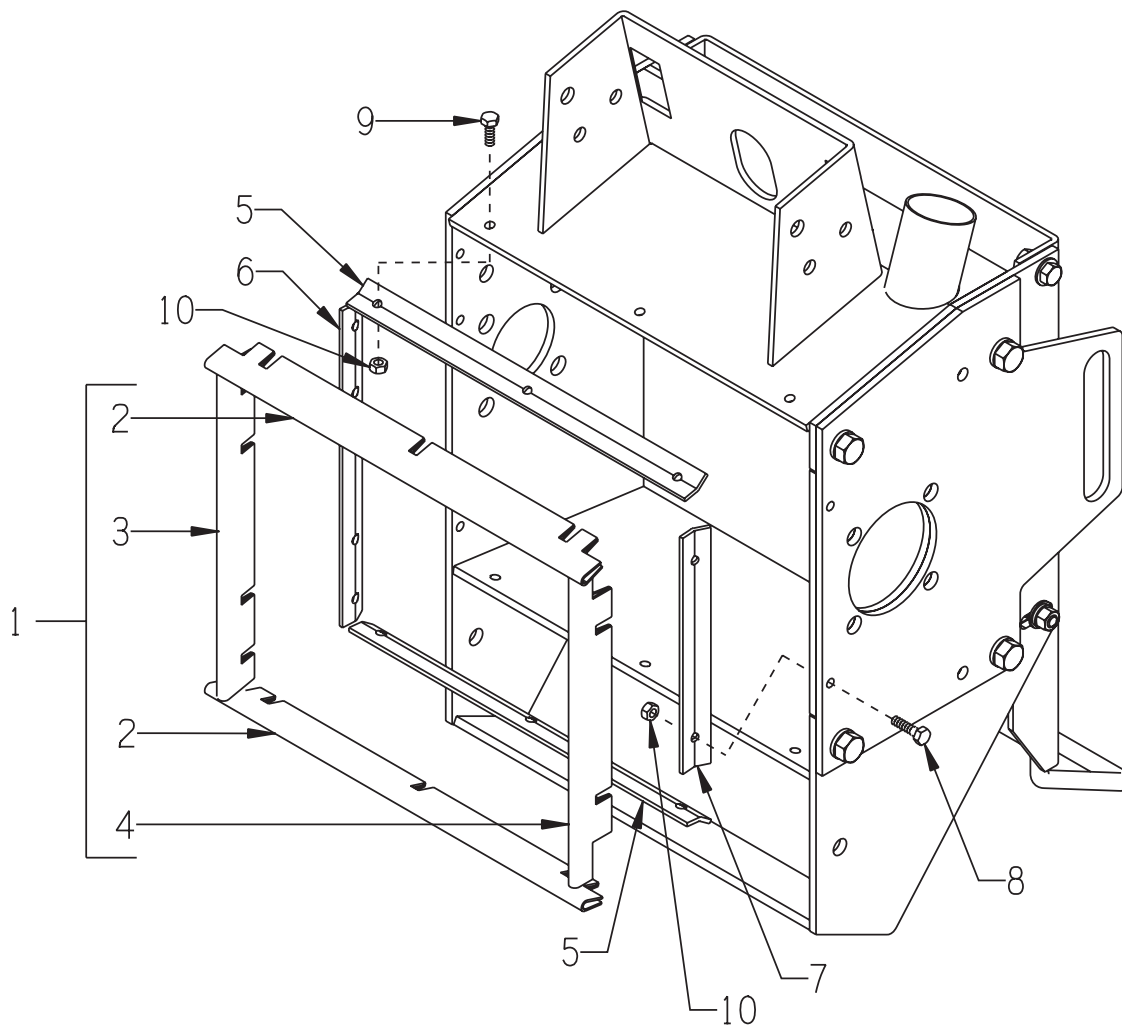

ITEM #	PART #	DESCRIPTION	QTY.
1	65219S	RUBBER SEAL SET (INCLUDES ITEMS 2, 3, & 4)	1
2	65219-2	RUBBER SEAL, 3 X 14-3/4, CPM-10	2
3	65219-1	RUBBER SEAL, 3 X 11-1/8, CPM-10	1
4	65218	RUBBER SEAL, 3 X 10-3/4, CPM-10	1
5	65222	BRACKET 13-1/4", RUBBER SEAL, CPM10	2
6	65221	BRACKET 10-3/4", RUBBER SEAL, CPM10	1
7	65220	BRACKET 8", RUBBER SEAL, CPM-10	1
8	10031	SCREW, CAP 1/4-20 X 1	2
9	10018	SCREW, CAP 1/4-20 X 3/4	10
10	10861	NUT, KEPS 1/4-20	12

ILLUSTRATION 5: DRUM SHAFT & BEARING GROUPING

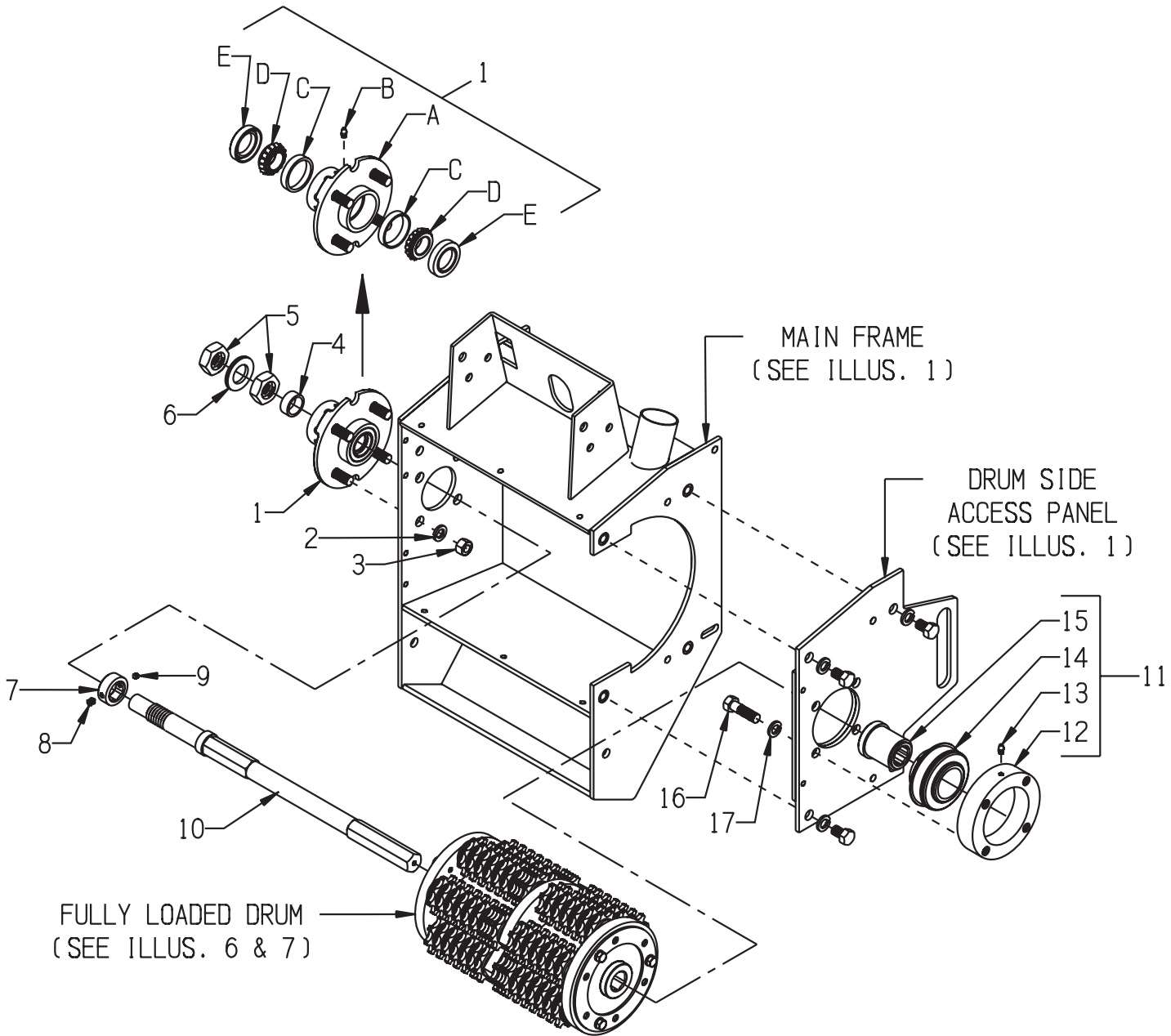

PARTS LISTING - ILLUSTRATIONS 5: DRUM SHAFT & BEARING GROUPING			
ITEM #	PART #	DESCRIPTION	QTY.
1	65227	HUB ASSY. W/ BRGS. & SEALS, CPM-10 (INCLUDES ITEMS 1A THRU 1E)	1
1A	65227H	HUB ONLY W/ RACES & GREASE HOLE (INCLUDES TWO ITEM #1C)	1
1B	10808	FITTING, GREASE 1/4-28 STRAIGHT	1
1C	86339	BEARING CUP/RACE # L44610 (INCLUDED W/ ITEM #1A)	2
1D	86321	BEARING, TAPERED ROLLER 1"ID CONE #L44643	2
1E	86322	SEAL, BEARING HUB, 1.25 X 1.986	2
2	10045	WASHER, LOCK 1/2 ZINC	4
3	10072	NUT 1/2-20	4
4	86319	SPACER, HUB BEARING (HARDENED) 1-1/4"OD x 1"ID x 1/2"L	1
5	50019	NUT, JAM 1-14 ZINC	2
6	86323	WASHER, NORD-LOCK 1" (PAIR)	1
7	65268	COLLAR, LOCKING 1"HEX, CPM-10 (INCLUDES 2 SET-SCREWS - SEE BELOW)	1
8	N/A	SCREW, SET 5/16-18 (INCLUDED W/ ITEM #7)	1
9	10139	SCREW, SET 1/4-20 X 5/16 (INCLUDED W/ ITEM #7)	1
10	65269	SHAFT, DRUM, 1"HEX X 20-3/4"L CPM10	1
11	65224A	BEARING SUBASSY., CPM-10 (INCLUDES ITEMS 12 THRU 15)	1
12	65225	RETAINER, BEARING, CPM-10	1
13	10808	FITTING, GREASE 1/4-28 STRAIGHT	1
14	65224	BEARING, BALL 1-3/4" W/ SNAP RING	1
15	65267	BUSHING, BEARING, 1"HEX, CPM-10	1
16	10498	SCREW, CAP 1/2-20 X 1-3/4	4
17	10045	WASHER, LOCK 1/2 ZINC	4

**ILLUSTRATION 6:
6-SHAFT CUTTER DRUM ASSEMBLY**

STANDARD

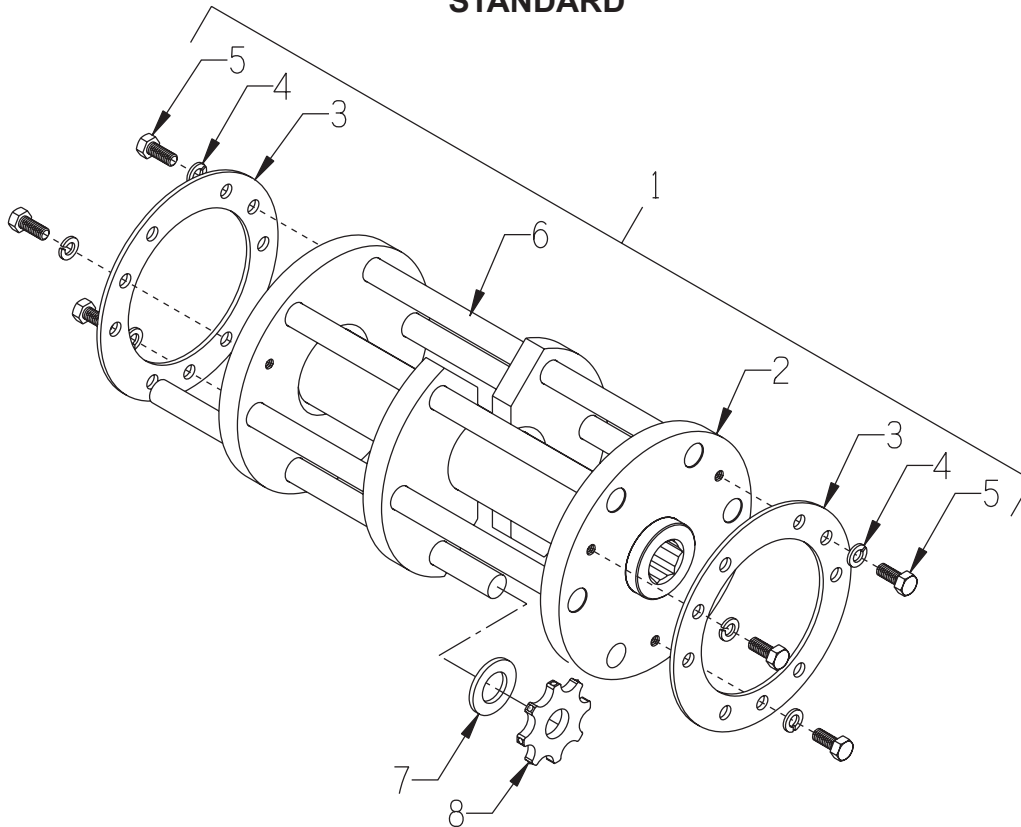

ITEM #	PART #	DESCRIPTION	QTY.
1*	65270	DRUM ASSEMBLY COMPLETE 6-SHAFT 1"HEX (INCLUDES ITEMS 2 THRU 6)	1
2	65271	DRUM ONLY, 6-SHAFT, 1" HEX BORE	1
3	65054	RETAINING PLATE, CUTTER SHAFT	2
4	10801	WASHER, LOCK 5/16 ZINC	6
5	10053	SCREW, CAP 5/16-18 X 3/4	6
6	20170	CP413 SHAFT 5/8 X 11-7/16, CPM-10	6
7*	20060	CP403 SPACER, HARDENED STEEL 1-1/2OD x 3/4ID	SEE NOTE
8*	20326	CUTTERS: CP308T 8-PT. CARBIDE 2-1/4"OD x 3/4"ID x 1/4"THK (SHOWN)	SEE NOTE
	20296	CP404P6 15-PT. POINTED STEEL 2-3/8"OD x 3/4"ID x 3/16"THK	
	20076	CP404 10-PT. FLAT TIP STEEL 2-3/8"OD x 1"ID x 3/16"THK	

***NOTE:**
CUTTER WHEELS AND SPACERS ARE NOT INCLUDED WITH THE DRUM ASSEMBLY.
THE NUMBER OF CUTTER WHEELS AND SPACERS VARY WITH TYPE OF SET-UP USED.
REFER TO ASSEMBLY INSTRUCTIONS FOR SUGGESTED SET-UPS AND QUANTITIES.

**ILLUSTRATION 7:
8-SHAFT CUTTER DRUM ASSEMBLY**

OPTIONAL

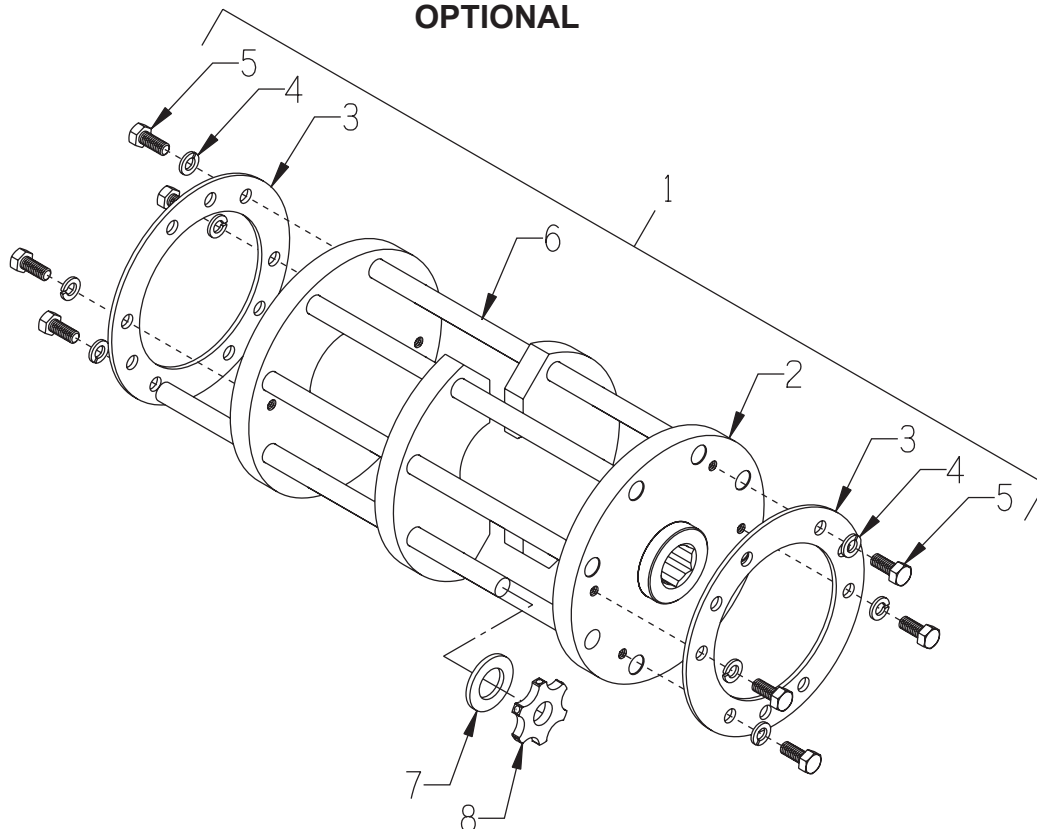

ITEM #	PART #	DESCRIPTION	QTY.
1*	65280	DRUM ASSEMBLY COMPLETE 8-SHAFT 1"HEX (INCLUDES ITEMS 2 THRU 6)	1
2	65281	DRUM ONLY, 8-SHAFT, 1" HEX BORE	1
3	65054	RETAINING PLATE, CUTTER SHAFT	2
4	10801	WASHER, LOCK 5/16 ZINC	8
5	10053	SCREW, CAP 5/16-18 X 3/4	8
6	20180	CP414 SHAFT 1/2 X 11-7/16, CPM-10	8
7*	20060	CP403 SPACER, HARDENED STEEL 1-1/2OD x 3/4ID	SEE NOTE
8*	20156 12206 20206 20336	CUTTERS: CP206T 6-PT. CARBIDE 1-3/4"OD x 5/8"ID x 1/4"THK (SHOWN) JRS501P 18-PT. POINTED STEEL 2"OD x 1/2"ID x 3/16"THK CP305 12-PT. FLAT TIP STEEL 2"OD x 5/8"ID x 3/16"THK CP207T 7-PT. SOLID CARBIDE MILLING 1-1/2"OD x 1/2"ID x 1/2"THK	SEE NOTE

***NOTE:**

CUTTER WHEELS AND SPACERS ARE NOT INCLUDED WITH THE DRUM ASSEMBLY.
THE NUMBER OF CUTTER WHEELS AND SPACERS VARY WITH TYPE OF SET-UP USED.
REFER TO ASSEMBLY INSTRUCTIONS FOR SUGGESTED SET-UPS AND QUANTITIES.



A Division of Equipment Development Company, Inc.

100 Thomas Johnson Drive, Frederick, MD 21702-4600 USA
Phone (301) 663-1600 • 1-800-638-3326
Fax (301) 663-1607 • 1-800-447-3326
Website: www.edcoinc.com
Email: sales@edcoinc.com

Printed in USA

JWA ©2011

Page 13

ILLUSTRATION 8: ENGINE GROUPING

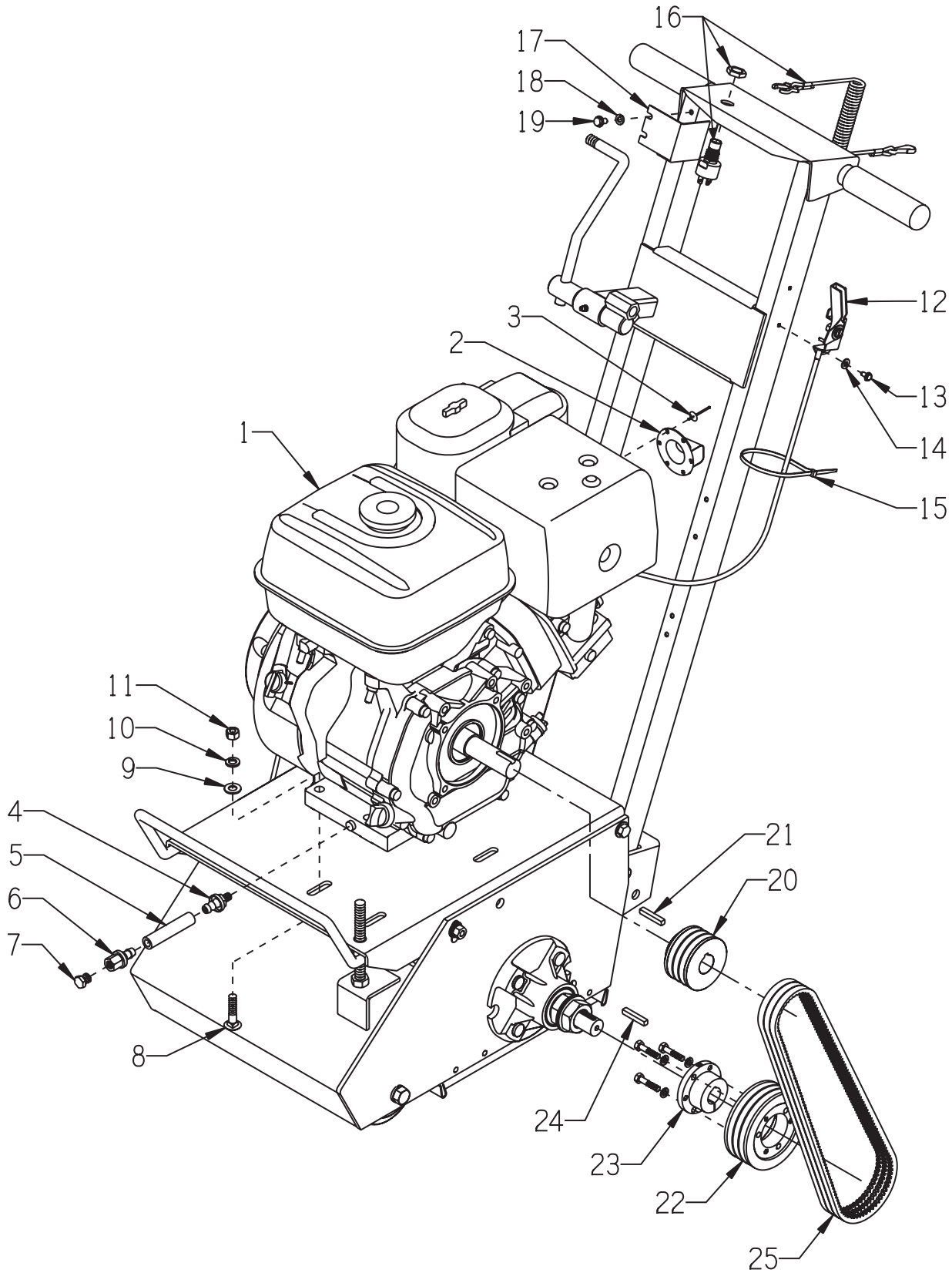

PARTS LISTING - ILLUSTRATION 8: ENGINE GROUPING			
ITEM #	PART #	DESCRIPTION	QTY.
1	15029	ENGINE, HONDA GX390U1-QXC9 CYC.A.C.	1
2	10625	MUFFLER CAP, HONDA #18331-ZE3-811	1
3	10128	RIVET, BLIND 1/8 X .250L X .262HD	2
4	11544	BARB, PUSH-ON 3/8 HOSE X 1/4FPT	1
5	56116	HOSE, PUSH-ON 3/8"ID X 3"L	1
6	11542	BARB, PUSH-ON 3/8HOSE X M12-1.5MALE	1
7	10776	PIPE PLUG 1/4 NPT (BRASS)	1
8	10087	BOLT, CARRIAGE 3/8-16 X 1-3/4 F.T.	4
9	10025	WASHER, FLAT 3/8 SAE ZINC	4
10	10811	WASHER, LOCK 3/8 ZINC	4
11	10404	NUT 3/8-16	4
12	40388	CABLE, THROTTLE, LEVER-TYPE 24"	1
13	10877	SCREW, CAP STSHW 10-24 X 1/2	2
14	10831	WASHER, LOCK, INT. TOOTH #10	2
15	10982	TIE, CABLE, BLACK NYLON 11-1/4"	1
16	65293	SWITCH, SAFETY TETHER E-STOP ADDITIONAL PARTS REQ'D. (NOT SHOWN):	1
	10457	WASHER, LOCK, INT. TOOTH 5/8"	1
	65295	WIRE, 65" BLK 14AWG, CPM10 E-STOP	1
	65296	WIRE, 4" BLK 14AWG, E-STOP GROUND	1
	10970	CONN., WIRE QUICK-SPLICE 18-14 GA.	1
	10955	TERM., FEM. PUSH-ON 1/4" 16-14GA.	2
	10982	TIE, CABLE, BLACK NYLON 11-1/4"	3
	10877	SCREW, CAP STSHW 10-24 X 1/2	1
	10831	WASHER, LOCK, INT. TOOTH #10	1
	50084	TERM., RING #10 16-14GA. INSULATED	1
17	65294	COVER, E-STOP SWITCH, CPM10	1
18	10038	WASHER, LOCK 1/4 ZINC	2
19	10846	SCREW, CAP STSHW 1/4-20 X 1/2	2
20	65238	SHEAVE 2.8"OD X 3GR.3V X 1"BORE	1
21	-----	KEY 1/4"SQ. X ? (INCLUDED W/ ENGINE)	1
22	65223	SHEAVE 4.12"OD X 3GR.3V X SH	1
23	10546	BUSHING, SHEAVE SH X 7/8"BORE	1
24	65254	KEY 3/16SQ X 7/8	1
25	10258	BELT 3VX-375	3

ILLUSTRATION 9: 60Hz MOTOR GROUPING

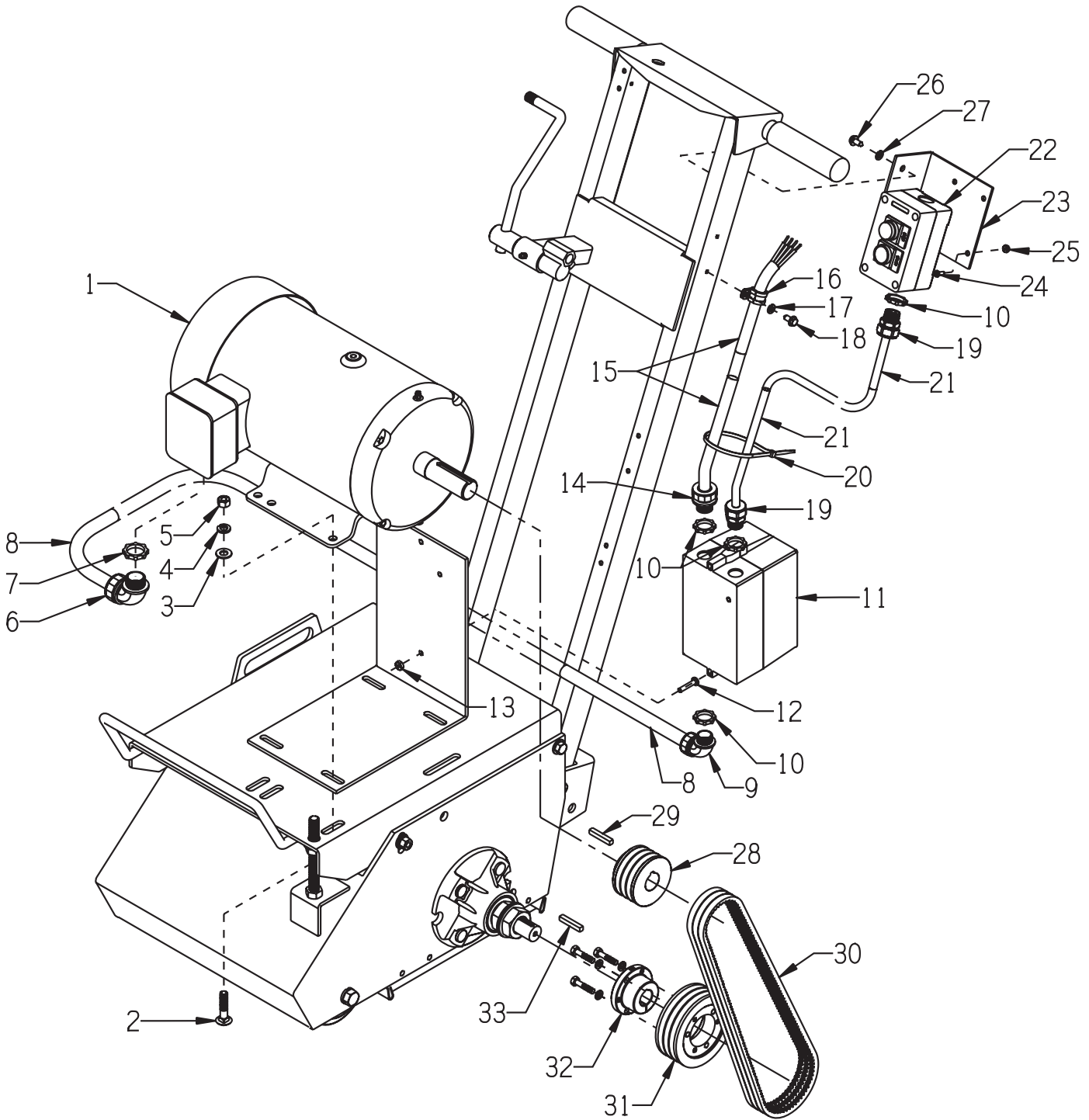

PARTS LISTING - ILLUSTRATION 9: 60Hz MOTOR GROUPING			
ITEM #	PART #	DESCRIPTION	QTY.
1	16002	MOTOR, BALDOR 7.5HP-3P 60HZ 3450RPM	1
2	10087	BOLT, CARRIAGE 3/8-16 X 1-3/4 F.T.	4
3	10025	WASHER, FLAT 3/8 SAE ZINC	4

PARTS LISTING CONTINUED - ILLUSTRATION 9: 60Hz MOTOR GROUPING			
ITEM #	PART #	DESCRIPTION	QTY.
4	10801	WASHER, LOCK 5/16 ZINC	4
5	10404	NUT 3/8-16	4
6	10984	CONN., LIQUID TITE 90D X 3/4NPT	1
7	10740	CONDUIT LOCK NUT 3/4 NP	1
8	65108	WIRE HARNESS 10/4 X 32"LOA	1
9	11621	STRAIN RELIEF 1/2"90D X .625-.750"	1
10	10790	CONDUIT LOCK NUT 1/2 NP	4
11	16454	STARTER ACI #128827, 230V 17.5-21.5A	1
	16459	STARTER ACI #128849, 460V 7.2-10.0A	1
		REPLACEMENT PARTS:	
	16617	STARTER CONTACTOR W/ COIL ACI SK18.310-230	1
	16618	STARTER CONTACTOR W/ COIL ACI SK18.310-460	1
	16622	STARTER AC COIL 200/240V-60HZ	1
	16623	STARTER AC COIL 440/480V-60HZ	1
	16637	STARTER OVERLOAD RELAY 17.5-21.5 AMP	1
16633	STARTER OVERLOAD RELAY 7.2-10.0 AMP	1	
12	11732	SCREW, MACHINE 10-32 X 1-3/4 RPH	2
	10384	SCREW, MACHINE 10-32 X 1 RPH	1
13	10832	NUT, KEPS 10-32	3
14	41053	STRAIN RELIEF 1/2NPT X .625-.750"	1
15	65105	WIRE HARNESS 10/4 X 48"LOA	1
16	11565	CLAMP, LOOM, 5/8" (SAE SIZE 10)	1
17	10846	SCREW, CAP STSHW 1/4-20 X 1/2	1
18	10038	WASHER, LOCK 1/4 ZINC	1
19	40066	STRAIN RELIEF 1/2NPT X .350-.450"	2
20	10982	TIE, CABLE, BLACK NYLON 11-1/4"	3
21	65106	WIRE HARNESS 16/4 X 48"LOA	1
22	16456	REMOTE SWITCH BOX COMPLETE ACI 104548	1
		REPLACEMENTS:	
	16456-6	PUSH-BUTTON, GREEN W/CONTACTOR	1
	16456-7	PUSH-BUTTON, RED W/ CONTACTOR	1
23	65122	BRACKET, REMOTE SWITCH	1
24	11663	SCREW, MACHINE 8-32 X 1/2	4
25	10462	NUT, KEPS 8-32	4
26	10846	SCREW, CAP STSHW 1/4-20 X 1/2	2
27	10038	WASHER, LOCK 1/4 ZINC	2
28	56314	SHEAVE 2.8"OD X 3GR.3V X 1-1/8"BORE	1
29	----	KEY 1/4"SQ. (INCLUDED W/ MOTOR)	1
30	10258	BELT 3VX-375	3
31	65223	SHEAVE 4.12"OD X 3GR.3V X SH	1
32	10546	BUSHING, SHEAVE SH X 7/8"BORE	1
33	65254	KEY 3/16SQ X 7/8	1

WIRING DIAGRAM FOR STARTER & REMOTE SWITCH

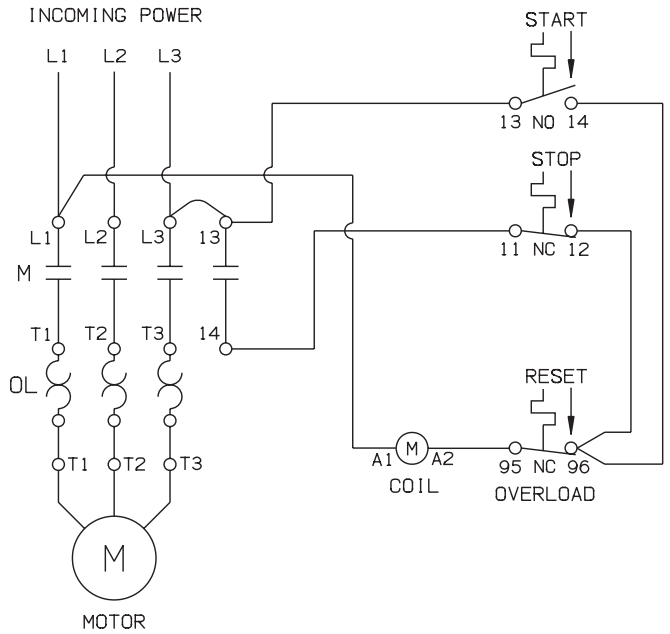
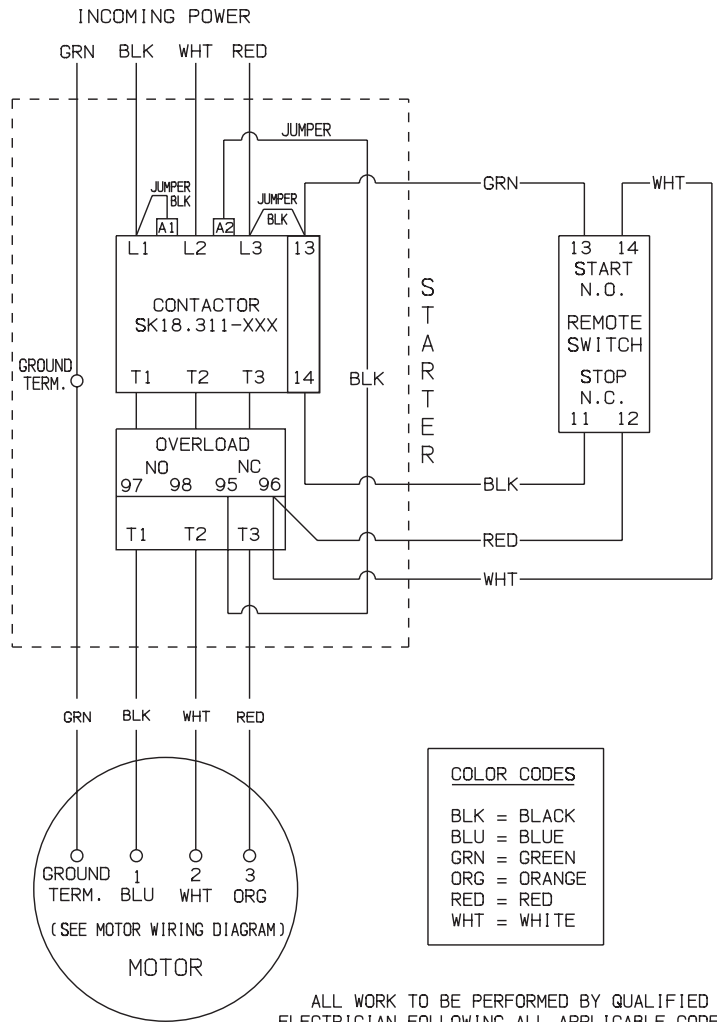

WIRING DIAGRAM FOR 60Hz MOTOR

BALDOR CAT. NO. M3616T
 7.5 H.P., 3 PHASE, 60 HERTZ, 3450 RPM,
 230/460 VOLT, 17.4/8.7 FULL LOAD AMPS

CD0005

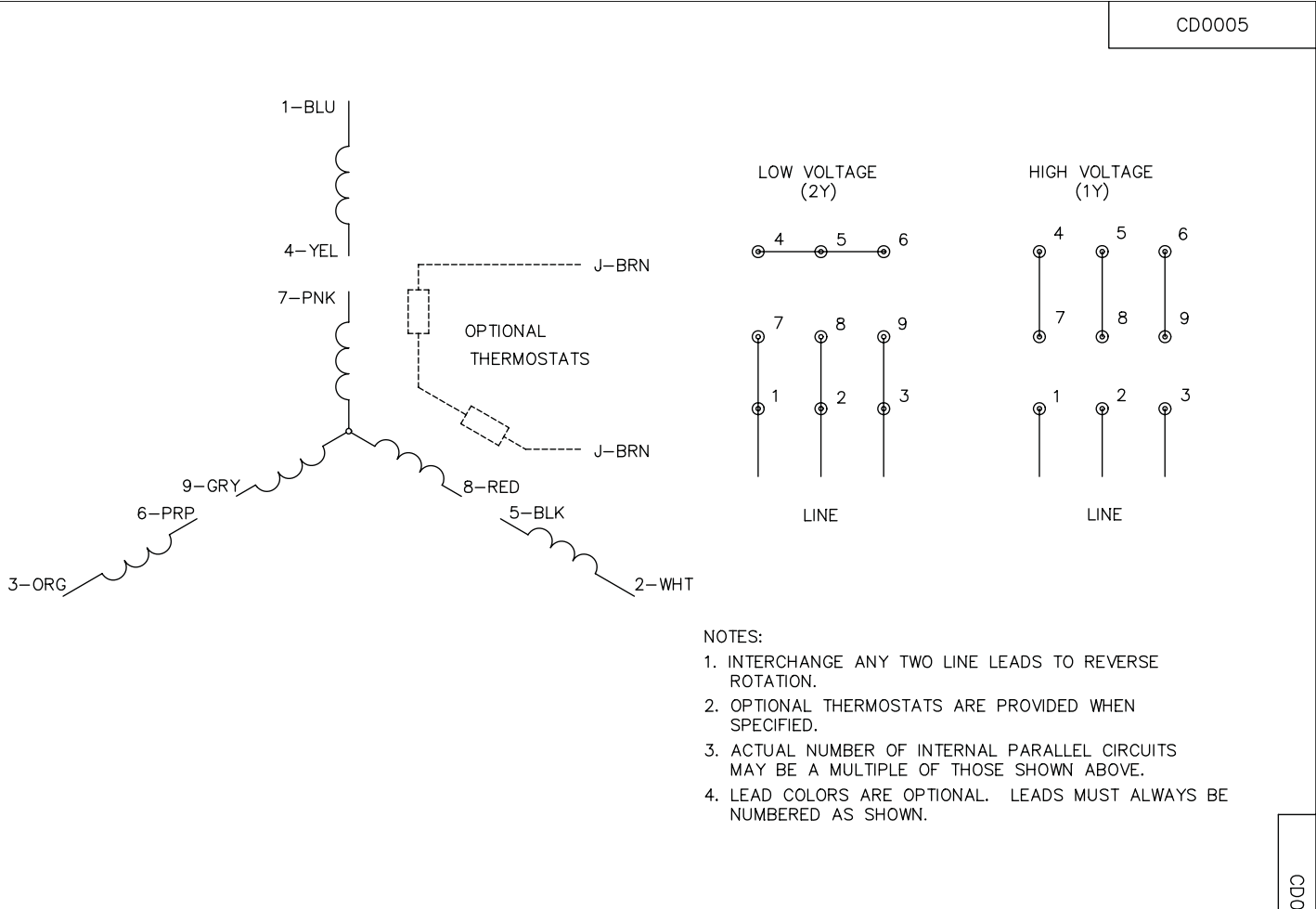

- NOTES:
1. INTERCHANGE ANY TWO LINE LEADS TO REVERSE ROTATION.
 2. OPTIONAL THERMOSTATS ARE PROVIDED WHEN SPECIFIED.
 3. ACTUAL NUMBER OF INTERNAL PARALLEL CIRCUITS MAY BE A MULTIPLE OF THOSE SHOWN ABOVE.
 4. LEAD COLORS ARE OPTIONAL. LEADS MUST ALWAYS BE NUMBERED AS SHOWN.

REV. DESC: REVISE TO SHOW OPTIONAL COLORS			
REV. LTR: E	BY: JLP	REVISED: 01/19/99 10:15	TDR: 0171435
S00000		FILE: AAA00005140	MDL: -
		MTL: -	

BALDOR ELECTRIC Co.

3PH, DV, 9 LEADS

CD0005



100 Thomas Johnson Drive, Frederick, MD 21702-4600 USA
 Phone (301) 663-1600 • 1-800-638-3326
 Fax (301) 663-1607 • 1-800-447-3326
 Website: www.edcoinc.com
 Email: sales@edcoinc.com

LIMITED EQUIPMENT WARRANTY OF SALE – TERMS & CONDITIONS

Equipment Development Company, Inc. herein referred to as EDCO (Seller) warrants that each new unit manufactured by EDCO to be free from defects in material and workmanship in normal use and service for a period of (1) one year (except for the cutter drum assembly on all model concrete/asphalt planes, in which case the warranty period shall be 90 days) from date of shipment to the original retail or equipment rental center owner.

Accessories or equipment furnished and installed on the product by EDCO but manufactured by others, including, but not limited to engines, motors, electrical components, transmissions etc., shall carry the accessory manufacturers own warranty.

EDCO will, at its option, repair or replace, at the EDCO factory or at a point designated by EDCO, any part which shall appear to the satisfaction of EDCO inspection to have been defective in material or workmanship.

EDCO reserves the right to modify, alter and improve any part or parts without incurring any obligation to replace any part or parts previously sold without such modified, altered or improved part or parts.

This warranty is in lieu of and excludes all other warranties, expressed, implied, statutory, or otherwise created under applicable law including, but not limited to the warranty of merchantability and the warranty of fitness for a particular purpose in no event shall seller or the manufacturer of the product be liable for special, incidental, or consequential damages, including loss of profits, whether or not caused by or resulting from the negligence of seller and/or the manufacturer of the product unless specifically provided herein. In addition, this warranty shall not apply to any products or portions thereof which have been subjected to abuse, misuse, improper installation, maintenance, or operation, electrical failure or abnormal conditions and to products which have been tampered with, altered, modified, repaired, reworked by anyone not approved by seller or used in any manner inconsistent with the provisions of the above or any instructions or specifications provided with or for the product

FORCE MAJEURE

Seller's obligation hereunder are subject to, and Seller shall not be held responsible for, any delay or failure to make delivery of all or any part of the Product due to labor difficulties, fires, casualties, accidents, acts of the elements, acts of God, transportation difficulties, delays by a common carrier, inability to obtain Product, materials or components or qualified labor sufficient to timely perform part of or all of the obligations contained in these terms and conditions, governmental regulations or actions, strikes, damage to or destruction in whole or part of manufacturing plant, riots, terrorist attacks or incidents, civil commotions, warlike conditions, flood, tidal waves, typhoon, hurricane, earthquake, lightning, explosion or any other causes, contingencies or circumstances within or without the United States not subject to the Seller's control which prevent or hinder the manufacture or delivery of the Products or make the fulfillment of these terms and conditions impracticable. In the event of the occurrence of any of the foregoing, at the option of Seller, Seller shall be excused from the performance under these Terms and Conditions, or the performance of the Seller shall be correspondingly extended.

This document sets forth the terms and conditions pursuant to which the purchaser ("Purchaser") will purchase and Equipment Development Co. Inc. ("Seller") will sell the products, accessories, attachments (collectively the Products) ordered by the Purchaser. These terms and conditions shall govern and apply to the sale of Seller's Products to Purchaser, regardless of any terms and conditions appearing on any purchase order or other forms submitted by Purchaser to Seller, or the inconsistency of any terms therein and herein.

1. PRICE

All prices set forth on any purchase order or other document are F.O.B. Seller's facility or distribution point, as may be determined by Seller (F.O.B. Point). All prices are exclusive of any and all taxes, including, but not limited to, excise, sales, use, property or transportation taxes related to the sale or use of the Products, now or hereafter imposed, together with all penalties and expenses. Purchaser shall be responsible for collecting and/or paying any and all such taxes, whether or not they are stated in any invoice for the Products. Unless otherwise specified herein, all prices are exclusive of inland transportation, freight, insurance and other costs and expenses relating to the shipment of the Products from the F.O.B. point to Purchaser's facility. Any prepayment by Seller of freight insurance and other costs shall be for the account of Purchaser and shall be repaid to Seller.

2. PAYMENT TERMS

Payment terms are as follows. 2% 10 days (to approved and qualified accounts). Net 30 days. This is a cash discount for invoices paid within 10 days after the invoice date, regardless of date of receipt of shipment. This is not a trade discount and will not be granted to accounts that do not adhere to stated terms.

*All past due accounts are subject to a late payment fee of 1.5% per month or a maximum allowed by law if different, along with the expenses incidental to collection including reasonable attorney's fees and costs.

*Seller reserves the right to hold shipments against past due accounts.

*Seller reserves the right to alter payment terms.

3. FREIGHT TERMS

All shipments will be made F.O.B. shipping point as designated in these Terms and Conditions, and title shall pass at the F.O.B. point. Delivery to the initial common carrier shall constitute delivery to the Purchaser. Any claims for loss or damage during shipment are to be filed with carrier by the Purchaser. Seller will not assume responsibility for the performance of the carrier.

Back orders will be shipped in the most practical fashion with charges consistent with our freight policy established with the original order. UPS, FED EX, MAIL or shipments by other couriers are subject to the same terms and conditions as outlined in paragraph #3 "Freight Terms".

4. DELIVERY, DAMAGES, SHORTAGES

Seller shall use reasonable efforts to attempt to cause the Products to be delivered as provided for in these Terms & Conditions. Delivery to the initial common carrier shall constitute the delivery to the Purchaser. Seller's responsibility, in so far as transportation risks are concerned ceases upon the delivery of the Products in good condition to such carrier at the F.O.B. point and all the Products shall be shipped at the Purchaser's risk. Seller shall not be responsible or liable for any loss of income and/or profits, or incidental, special, consequential damages resulting from Seller's delayed performance in shipment and delivery.

5. RETURN OF DEFECTIVE PRODUCTS

Defective or failed material shall be held at the Purchaser's premises until authorization has been granted by Seller to return or dispose of Products. Products that are to be returned for final inspection must be returned Freight Prepaid in the most economical way. Credit will be issued for material found to be defective upon Seller's inspection based on prices at time of purchase.

6. PRODUCTS ORDERED IN ERROR

Products may be returned, provided that claim is made and Seller is notified within 7 days of receipt of Products, and the Products are in original buyer's possession not more than 30 days prior to return, subject to Seller's approval. If Products are accepted for return, they must be Freight Prepaid and buyer will be charged a minimum of 15% restocking charge, plus a charge back for outbound freight charges if the original order was shipped prepaid. Returns are not accepted for any Products that are specifically manufactured to meet the buyer's requirement of either specifications or quantity.

AGREEMENTS

These Terms and Conditions constitute the entire agreement between Seller and Purchaser as it relates to terms and conditions of sale, and supersedes any and all prior oral or written agreements, correspondence, quotations or understandings heretofore in force between the parties relating to the subject matter hereof. There are no agreements between Seller and Purchaser with respect to the Product herein except those specifically set forth in and made part of these terms and conditions. Any additional terms, conditions and/or prices are rejected by Seller.

These terms and conditions may be modified, cancelled or rescinded only by a written agreement of both parties executed by their duly authorized agents.

USE ONLY GENUINE EDCO PARTS & ACCESSORIES
For your own safety, the safety of others and the life of your machine.

Equipment Development Company, Inc.

