

## Parts List Manual

# VAC-200



**Manual - Portable**

READ AND UNDERSTAND THE OPERATORS INSTRUCTION MANUAL THOROUGHLY BEFORE ATTEMPTING TO OPERATE THIS EQUIPMENT. Death or serious injury could occur if this machine is used improperly.



## SAFETY MESSAGES



The safety instructions are preceded by a graphic alert message of DANGER, WARNING, or CAUTION.



Indicates an imminent hazard which, if not avoided, will result in death or serious injury.



Indicates an imminent hazard which, if not avoided, can result in death or serious injury.



Indicates hazards which, if not avoided, could result in serious injury and or damage to the equipment.

## GASOLINE Powered Equipment



- Do not operate gasoline powered equipment without adequate ventilation. Carbon monoxide is an invisible, odorless gas that can kill.

## ELECTRICAL Powered Equipment



- ELECTRICAL HAZARD** - Be sure equipment is properly grounded. Failure to comply could kill or result in serious injury.



The engine exhaust from this product contains chemicals known to the State of California to cause cancer, birth defects or other reproductive harm.

## GENERAL INSTRUCTIONS



- You must read and understand the operators instruction manual and all other manuals associated with this machine. For your safety and the safety of others around you, it is extremely important to fully understand how to operate this machine in the way it was intended. Different model machines or older/newer versions of the same model may have different parts and controls that you need to understand. If instructions are not readable or available DO NOT USE this machine and contact the factory for a replacement Manual.
- You must be able to physically handle the bulk weight and power of this machine. If not properly controlled this machine can cause death or serious injury.
- Do not operate this machine in an impaired mental state. You must be able to exercise good judgement and reactions to maintain a safe working environment.
- This is a "one person" machine which means only one operator can be operating the machine at any one time. For the safety of others, maintain a safe operating distance to other personnel. Your work area should be defined and appropriately marked so bystanders and coworkers do not stand or walk near this machine and end up seriously injured by flying debris or exposing them to harmful noise or dust.
- This equipment is for Commercial use. Although this is a "one person" machine your work team should understand how to shut this machine off and quickly get medical help if an accident strikes the operator.
- Keep all guards in place during operation. The guards are to provide protection from inadvertent contact with dangerous moving parts, pinch points, or hot surfaces.
- Wear appropriate Personal Protective Equipment (PPE) including safety glasses, safety boots, work gloves, respiratory protection, hearing protection, and head protection. Do not wear loose clothing that can get tangled in moving parts. Failure to do so could result

in dismemberment or death. **Wear an approved respirator when removing hazardous materials or when grinding/cutting dry materials. Some dust particles such as concrete dust can contain silicate particles which can cause silicosis (a very serious lung disease). Contact NIOSH or OSHA for further details. When wet grinding/cutting, avoid contact with the concrete/asphalt slurry which can cause serious skin irritations.**

- You must maintain this machine per the maintenance schedule in the operator manual. Remember before adjusting, servicing, or fueling this machine, disconnect the source of power to the machine by disconnecting the spark plug (Gas models), or by unplugging the electrical power cord (electric models) or air hose (Pneumatic models) AT THE MACHINE so you can assure yourself it remains unplugged while you are working on it. Do not modify this machine. Use only genuine EDCO parts and accessories. Repairs and service should be performed by approved EDCO dealers or authorized technicians.
- You should look carefully around the area before you begin work so you can identify potential hazards such as deck inserts, pipes, columns, openings, electrical cords or outlets, or any other objects protruding from the slab surface.
- This machine has no brain so you must use your own. There is no substitute for safety. The safety decals on the machine are to serve as a reminder for information you must already know before you begin using this machine. Take a moment to reread the safety decals each time you use the machine. If your machine is missing any decals, contact the factory for a replacement (EDCO 1-800-638-3326).

# PARTS LIST MANUAL

## MODEL VAC-200

<u>Section</u>	<u>Page Number</u>
Safety Messages / General Instructions . . . . .	2
How To Order Replacement Parts . . . . .	3
Illustration 1 : 1000 Motor Deck Assembly . . . . .	4,5
Illustration 2 : 2220 Motor Deck Assembly . . . . .	6,7
Illustration 3 : 1000 Switch assembly . . . . .	8,9
Illustration 4 : 2220 Switch Assembly . . . . .	10,11
Illustration 5 : Filter Assemblies . . . . .	12,13
Illustration 6 : Hepa Filter & MiniHelic Assembly . . . . .	14,15
Illustration 7 : Base Assembly . . . . .	16,17
Illustration 8 : Dust Pan Lever Assembly . . . . .	18,19
Illustration 9 : Inlet Assemblies . . . . .	20,21
Illustration 10 : Hose & Adaptor . . . . .	22
Blank . . . . .	23
Limited Equipment Warranty . . . . .	Back Cover

<p><b>HOW TO ORDER REPLACEMENT PARTS</b></p> <ul style="list-style-type: none"> <li><input type="checkbox"/> To insure product safety and reliability, always use genuine EDCO replacement parts when making repairs to the equipment.</li> <li><input type="checkbox"/> When calling for parts, specify the MODEL and SERIAL number of the machine, which can be found on the NAME PLATE. Keep that information in the space provided. In addition to this information, give part number, description, and quantity as listed on the parts list to your parts representative.</li> <li><input type="checkbox"/> Please note: Due to improvements and changes in the equipment, the illustrations shown may be different than the actual machine.</li> </ul>	<p style="text-align: center;"><b>FILL IN INFORMATION BELOW</b></p> <p>Date of Purchase _____</p> <p>Model # _____</p> <p>Serial # _____</p> <p>SKU # _____</p>
--------------------------------------------------------------------------------------------------------------------------------------------------------------------------------------------------------------------------------------------------------------------------------------------------------------------------------------------------------------------------------------------------------------------------------------------------------------------------------------------------------------------------------------------------------------------------------------------------------------------------------------------------------------------------------------------------------------------------------------------------------------	-----------------------------------------------------------------------------------------------------------------------------------------------------------------



100 Thomas Johnson Drive, Frederick, MD 21702-4600 USA  
 Phone (301) 663-1600 • 1-800-638-3326  
 Fax (301) 663-1607 • 1-800-447-3326  
 Website: [www.edcoinc.com](http://www.edcoinc.com)  
 Email: [sales@edcoinc.com](mailto:sales@edcoinc.com)

# ILLUSTRATION #1 : 1000 MOTOR DECK ASSEMBLY

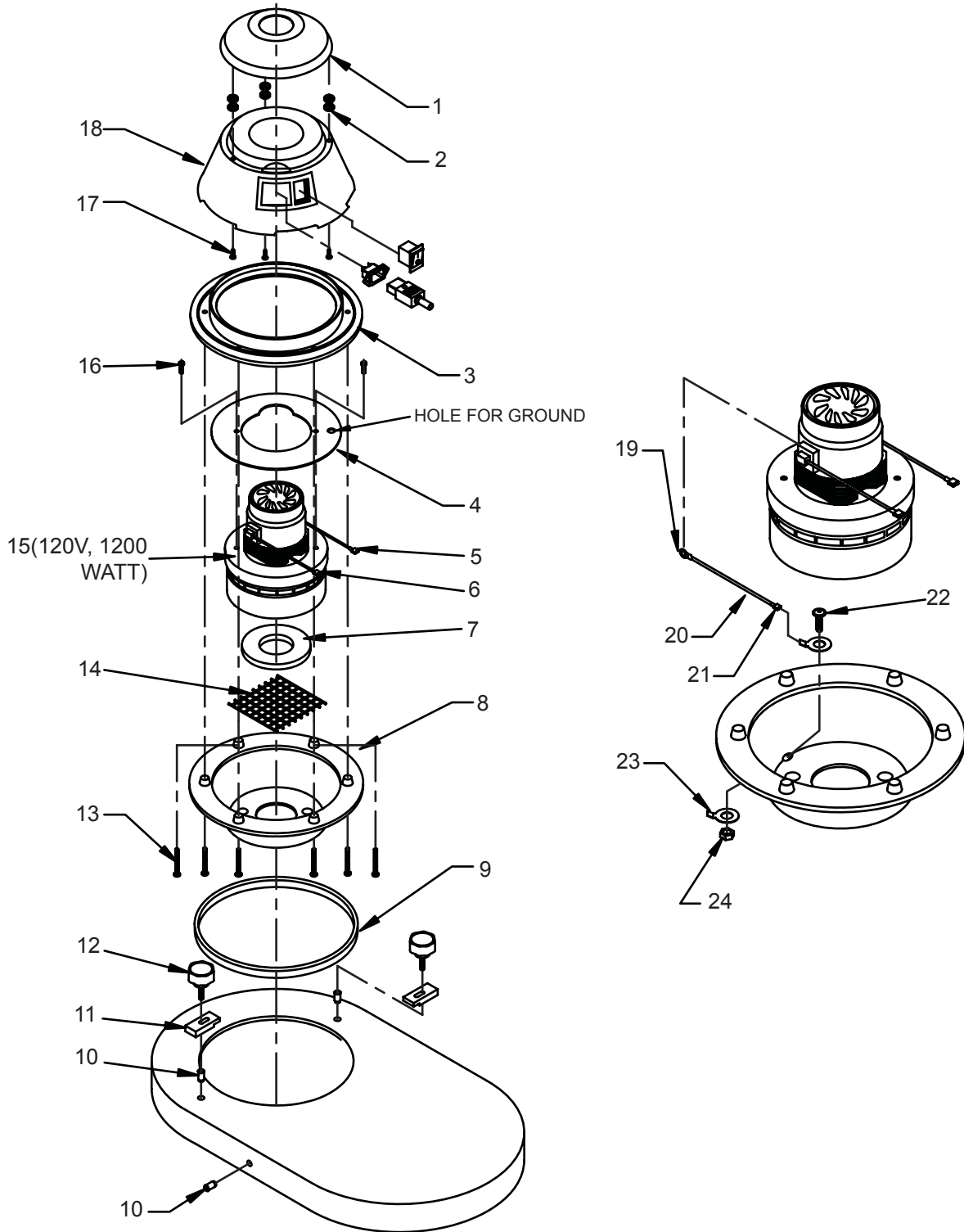

<b>PARTS LISTING - ILLUSTRATION #1 : 1000 MOTOR DECK ASSEMBLY</b>			
<b>ITEM #</b>	<b>PART #</b>	<b>DESCRIPTION</b>	<b>QTY</b>
1	ED27015	HOUSING COVER, SINGLE MOTOR	1
2	ED200432	NYLON WASHER, NOT USED	0
3	ED8004	SUPPORT RING FOR SINGLE MOTOR	1
4	ED27007	SEPARATOR PLATE,WNS MOTOR HEAD	1
5	ED31711	TERMINAL, 16/14 GAUGE, FEMALE, PUSHON BLUE NYLON	2
6	ED31011	TERMINAL, 16/14 GAUGE,PUSHON, FEMALE, NON-INSULATED	2
7	ED2509811	NEOPRENE SPONGE GASKET, 3/8" THICK, 5" OD,2-1/4" ID	1
8	ED27001	MOTOR HEAD, ALUMINUM	1
9	ED27004	GASKET FOR MOTOR HEAD	1
10	ED34817A	M6 BLIND PEM	4
11	ED20020	HOLD DOWN BRACKET, FOR WS MOTOR	2
12	ED26603	KNOB FOR MOTOR HOLD DOWN, M6	2
13	ED27003	#8 X 2" PHIL PAN HEAD, ZINC	6
14	ED8021	PROTECTION SCREEN, MOTOR HEAD	1
15	ED27000	MOTOR, 120V, 1200 W	1
16	ED32987	SHEET METAL SCREW, 4.2X16MM	2
17	ED27012	#8 X 1/2" PHIL PAN HEAD, ZINC	3
18	ED27014	MOTOR HOUSING, SINGLE	1
19	ED31503	TERMINAL, # 10 RING, 16/14 GAUGE	1
20	ED34993	GROUND CABLE, 16 GAUGE, GREEN	1
21	ED31711	TERMINAL, 16/14 GAUGE, FEMALE	1
22	ED34817	M6 X 20 ULS ALLEN HEAD SCREW	1
23	ED34998	GROUND CONNECTION, FOR BOLT	2
24	ED34876	M6 LOCK NUT, ZINC	1

# ILLUSTRATION #2 : 2220 MOTOR DECK ASSEMBLY

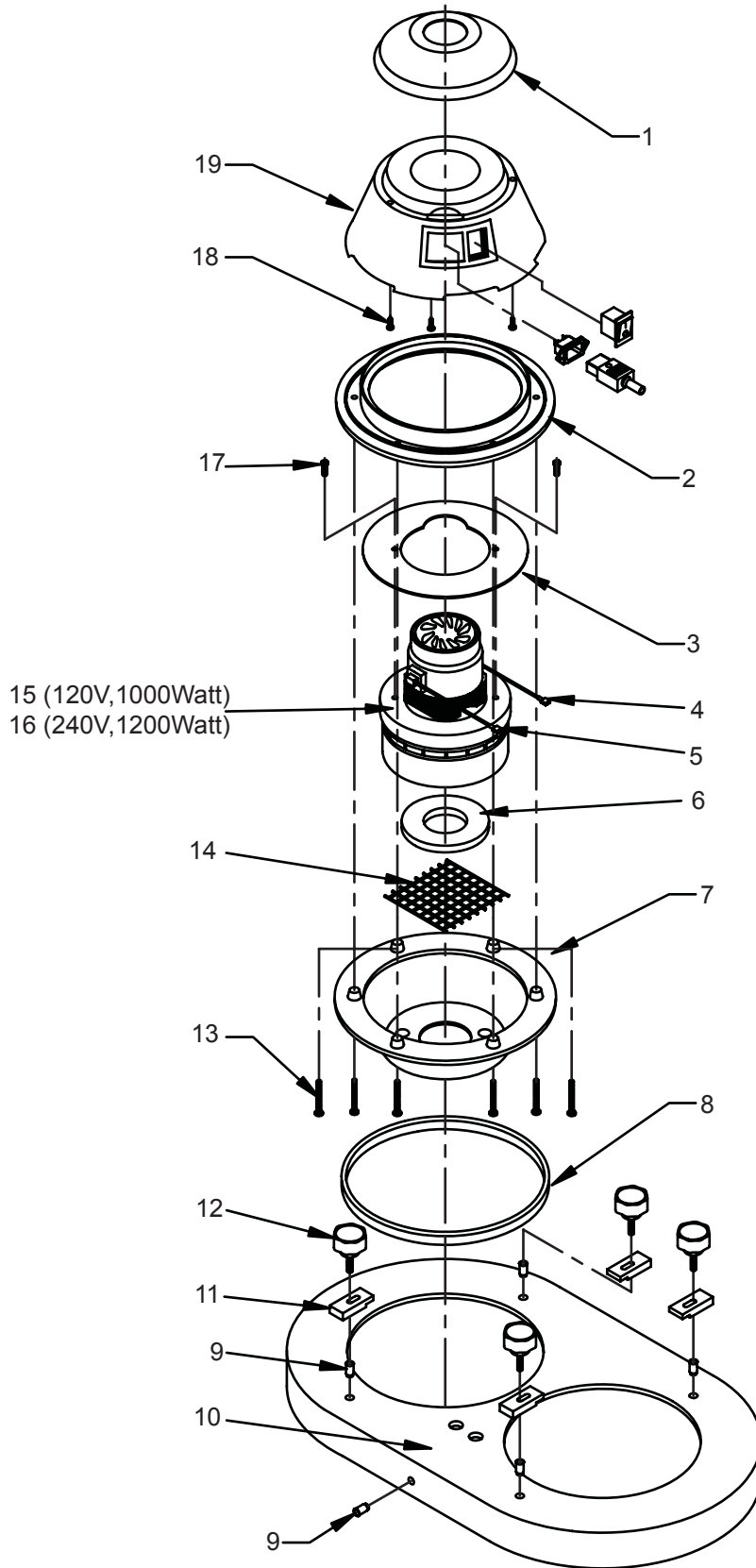

**PARTS LISTING - ILLUSTRATION #2 : 2220 MOTOR DECK ASSEMBLY**

ITEM #	PART #	DESCRIPTION	QTY
1	ED27015	HOUSING COVER, SINGLE MOTOR	2
2	ED8004	SUPPORT RING FOR SINGLE MOTOR	2
3	ED27007	SEPARATOR PLATE, WNS MOTOR HEAD	2
4	ED31711	TERMINAL, 16/14 GAUGE, FEMALE, PUSHON BLUE NYLON	4
5	ED31011	TERMINAL, 16/14 GAUGE, PUSHON, FEMALE, NON-INSULATED	4
6	ED2509811	NEOPRENE SPONGE GASKET	2
7	ED27001	MOTOR HEAD, ALUMINUM	2
8	ED27004	GASKET FOR MOTOR HEAD	2
9	ED34817A	M6 BLIND PEM	6
10	ED90223	WNS MOTOR DECK, RED, WNS, 2 MOTOR	1
11	ED20020	HOLD DOWN BRACKET, FOR WS MOTOR	4
12	ED26603	KNOB FOR MOTOR HOLD DOWN, M6	4
13	ED27003	#8 X 2" PHIL PAN HEAD, ZINC	12
14	ED8021	PROTECTION SCREEN, MOTOR HEAD	2
15	ED27002	MOTOR, 120V, 1000 WATT	2
16	ED116549-13	MOTOR, 240V, 1200 WATT	2
17	ED32987	SHEET METAL SCREW, 4.2X16MM	4
18	ED27012	#8 X 1/2" PHIL PAN HEAD, ZINC	6
19	ED27014	MOTOR HOUSING, SINGLE	2

# ILLUSTRATION #3 : 1000 SWITCH ASSEMBLY

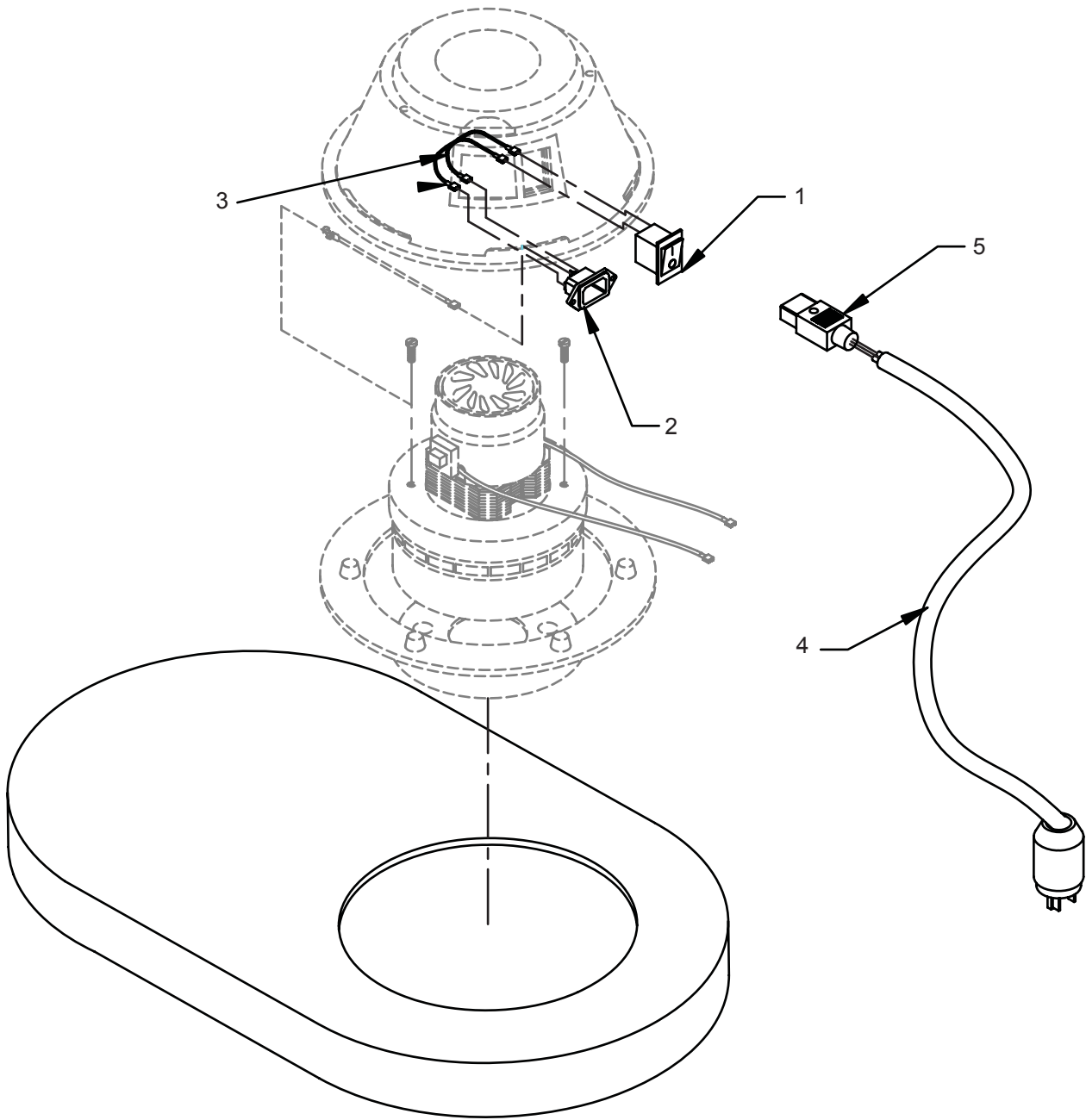



**PARTS LISTING - ILLUSTRATION #3 : 1000 SWITCH ASSEMBLY**

ITEM #	PART #	DESCRIPTION	QTY
1	ED27017	SWITCH, TOGGLE, WS, 1000/1200	1
2	ED25211	MALE IEC PLUG	1
3	ED34905A	GROUND WIRE FROM PLUG TO MOTOR	2
4	ED2005531	POWER CORD, 12/3 SJO W/MOLDED 110V PLUG	1
5	ED25209	FEMALE IEC PLUG	1

# ILLUSTRATION #4 : 2220 SWITCH ASSEMBLY

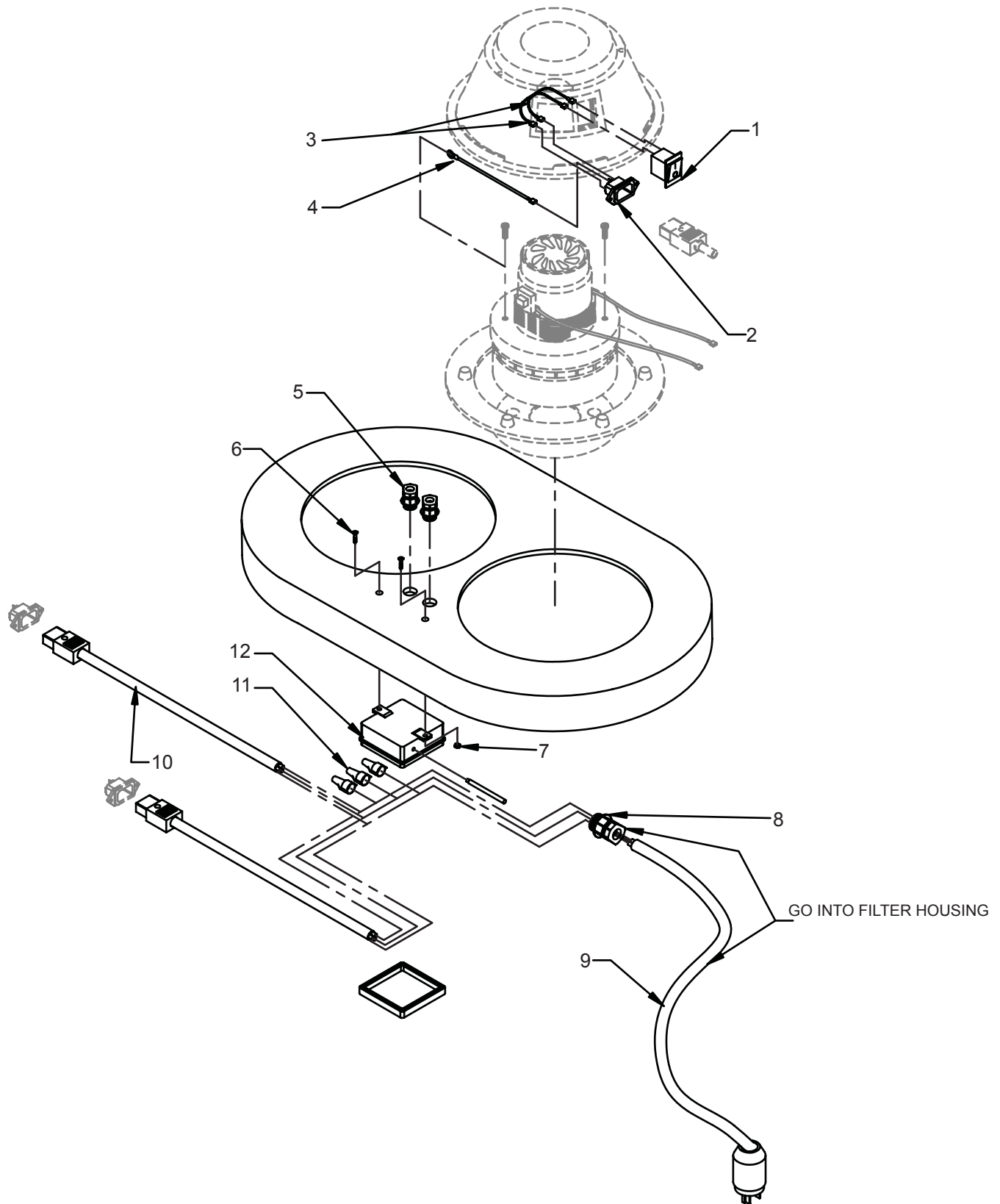

**PARTS LISTING - ILLUSTRATION #4 : 2220 SWITCH ASSEMBLY**

ITEM #	PART #	DESCRIPTION	QTY
1	ED27017	SWITCH, TOGGLE, WS, 1000/1200	2
2	ED25211	MALE IEC PLUG	2
3	ED34905A	GROUND WIRE FROM PLUG TO MOTOR	4
4	ED34993	GROUND CABLE, 16 GAUGE, GREEN	2
5	ED34960	PG 09 CABLE GRIP	2
6	ED25048	#8-32 X 3/4 PHILLIPS FLAT HEAD	2
7	ED25049	#8-32 HEX NUT	2
8	ED34955	PG 16, CABLE GRIP	1
9	ED2005531	POWER CABLE	1
10	ED25210	FEMALE IEC PLUG W/12" WIRE	2
11	ED21095	WIRE NUT, TWISTING	3
12	ED32999	JUNCTION BOX	1

# ILLUSTRATION #5 : FILTER ASSEMBLIES

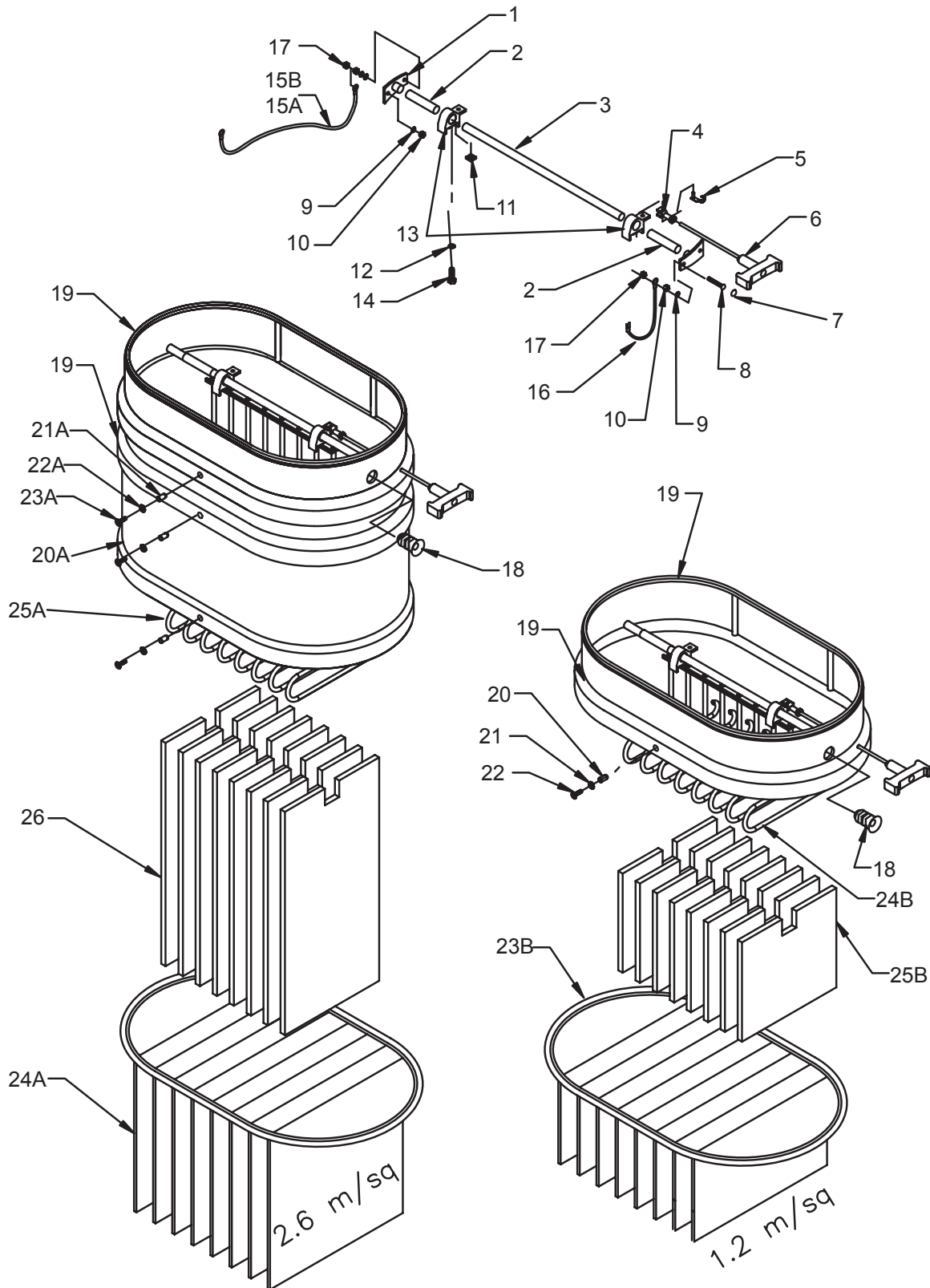

**PARTS LISTING - ILLUSTRATION #5 : 1.2 FILTER ASSEMBLY**

ITEM #	PART #	DESCRIPTION	QTY
1	ED34806	34806 SHAKER ROD MOUNTING SUPPORT	2
2	ED34805	CLEAR HOSE, 3/4 ID	2
3	ED34804	SLIDE BAR	1
4	ED25047	STEEL YOKE END	1
5	ED34879	SPRING CLIP, 6X12	1
6	ED22565	SHAKER BAR WITH SWIVEL HANDLE	1
7	ED34871	PLASTIC PLUG 4.5/13	4
8	ED34815	M6 X 30 ALLEN SCREW COUNTER SUNK	4
9	ED20039	M6 SPLIT LOCK WASHER	4
10	ED20040	M6 HEX NUT	4
11	ED20045	SQUARE NUT, 8MM, ZINC	2
12	ED20050	M8 LOCK WASHER	2
13	ED34802	SLIDE ASSEMBLY, W/HOOK	2
14	ED25038	M8 HEX CAP-1.25X20 ZINC	2
15B	ED34868	GROUND, DEFLECTOR, 1.2 FILTER	1
16	ED34866	GROUND, SHAKER TO MOTOR DECK	1
17	ED34876	M6 LOCK NUT	2
18	ED34955	PG 16 CABLE GRIP	1
19	ED34823	HOUSING SPACER, SMALL, RED	1
20	ED34817A	M6 BLIND PEM	2
21	ED25000	1/4" STAR WASHER	2
22	ED3481701	M6X25 ALLEN HEAD SCREW	2
23B	ED20091	FILTER, 13 SQ/FT, 1.2M2	1
24B	ED25056	FILTER SHAKER INSERT, 1.2M	1
25B	ED20091F	FILTER INSERT, 1.2M	8

**PARTS LISTING - ILLUSTRATION #5 : 2.6 FILTER ASSEMBLY**

ITEM #	PART #	DESCRIPTION	QTY
1	ED34806	34806 SHAKER ROD MOUNTING SUPPORT	2
2	ED34805	CLEAR HOSE, 3/4 ID	2
3	ED34804	SLIDE BAR	1
4	ED25047	STEEL YOKE END	1
5	ED34879	SPRING CLIP, 6X12	1
6	ED22565	SHAKER BAR WITH SWIVEL HANDLE	1
7	ED34871	PLASTIC PLUG 4.5/13	4
8	ED34815	M6 X 30 ALLEN SCREW COUNTER SUNK	4
9	ED20039	M6 SPLIT LOCK WASHER	4
10	ED20040	M6 HEX NUT	4
11	ED20045	SQUARE NUT, 8MM, ZINC	2
12	ED20050	M8 LOCK WASHER	2
13	ED34802	SLIDE ASSEMBLY, W/HOOK	2
14	ED25038	M8 HEX CAP-1.25X20 ZINC	2
15A	ED34869	GROUND, DEFLECTOR, 2.6 FILTER	1
16	ED34866	GROUND, SHAKER TO MOTOR DECK	1
17	ED34876	M6 LOCK NUT	2
18	ED34955	PG 16 CABLE GRIP	1
19	ED34823	HOUSING SPACER, SMALL, RED	2
20A	ED34820	HOUSING SPACER, LARGE, RED	1
21A	ED34817A	M6 BLIND PEM	6
22A	ED25000	1/4" STAR WASHER	6
23A	ED3481701	M6X25 ALLEN HEAD SCREW	6
24A	ED30091	FILTER, 28 SQ/FT, 2.6M2	1
25A	ED34807	FILTER SHAKER INSERT, 2.6M	1
26	ED30091F	FILTER INSERT, 2.6M	8

# ILLUSTRATION #6 : HEPA FILTER & MINIHHELIC ASSEMBLY

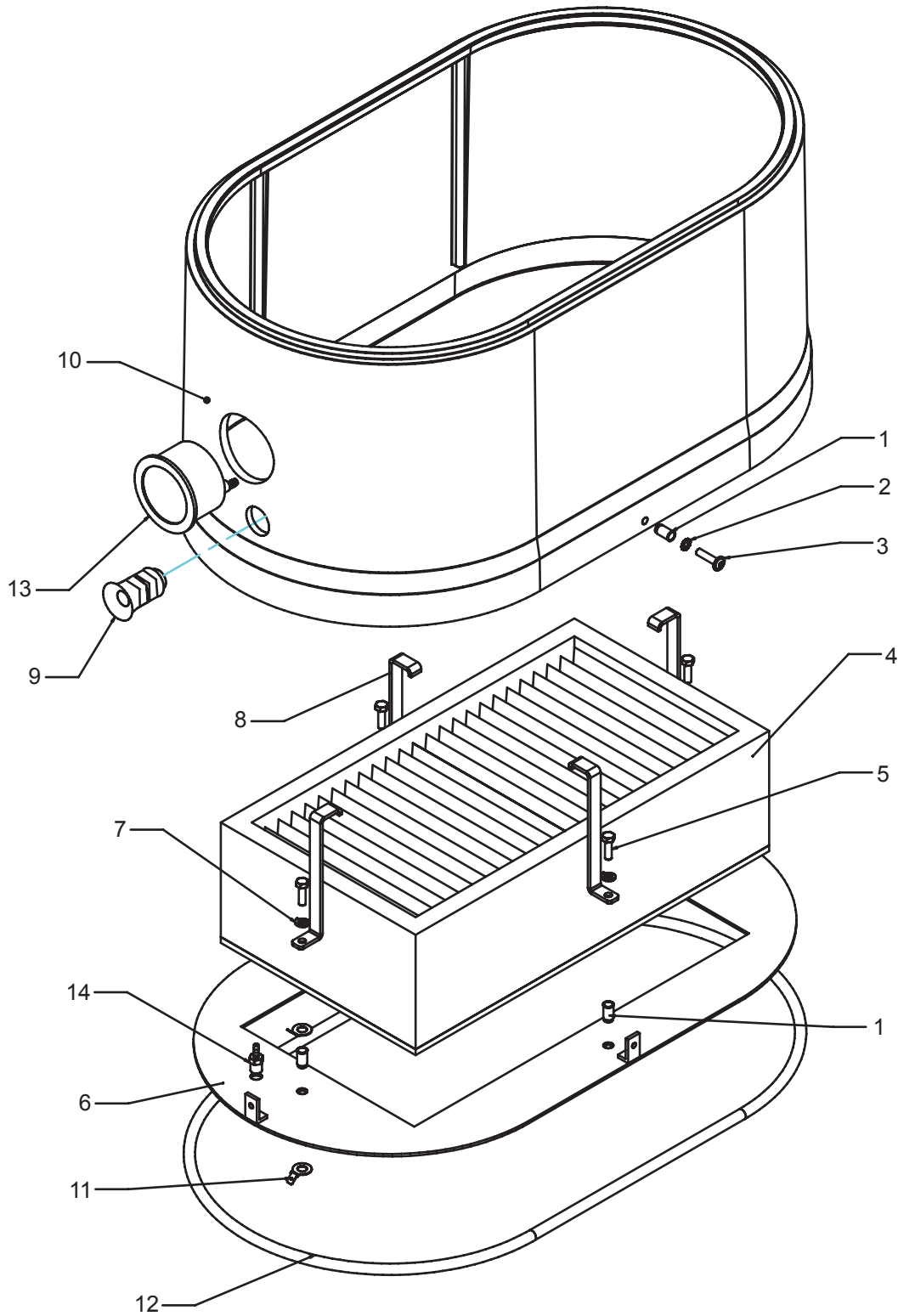

**PARTS LISTING - ILLUSTRATION #6 : HEPA FILTER & MINIHELIC ASSEMBLY**

ITEM #	PART #	DESCRIPTION	QTY
1	ED34817A	M6 BLIND PEM	6
2	ED25000	1/4" STAR WASHER, EXTERNAL	2
3	ED3481701	M6X25 ALLEN HEAD SCREW	2
4	ED35211	HEPA FILTER 40 SQ FOOT, WS, DS1	1
5	ED32903	M6X1.0 X 20 HEX CAP SCREW, ZINC	4
6	ED34947	HEPA ADAPTER PLATE, DS1	1
7	ED20039	M6 SPLIT LOCK WASHER	4
8	ED34949	HEPA HOLD DOWN BRACKET	4
9	ED34955	PG 16, CABLE GRIP	1
10	ED34820	HOUSING SPACER, LARGE, RED	1
11	ED34998	GROUND CONNECTION, FOR BOLT	2
12	ED25098	GASKET, ROUND, 10MM	1
13	ED25143	MINIHELIC, WITH MOUNTING	1
14	ED25149	HOSE BARB ,1/8 NPT X 1/8 BARB	1
15	ED34800	CLEAR HOSE, 1/8" ID 0.5	0.5

# ILLUSTRATION #7 : BASE ASSEMBLY

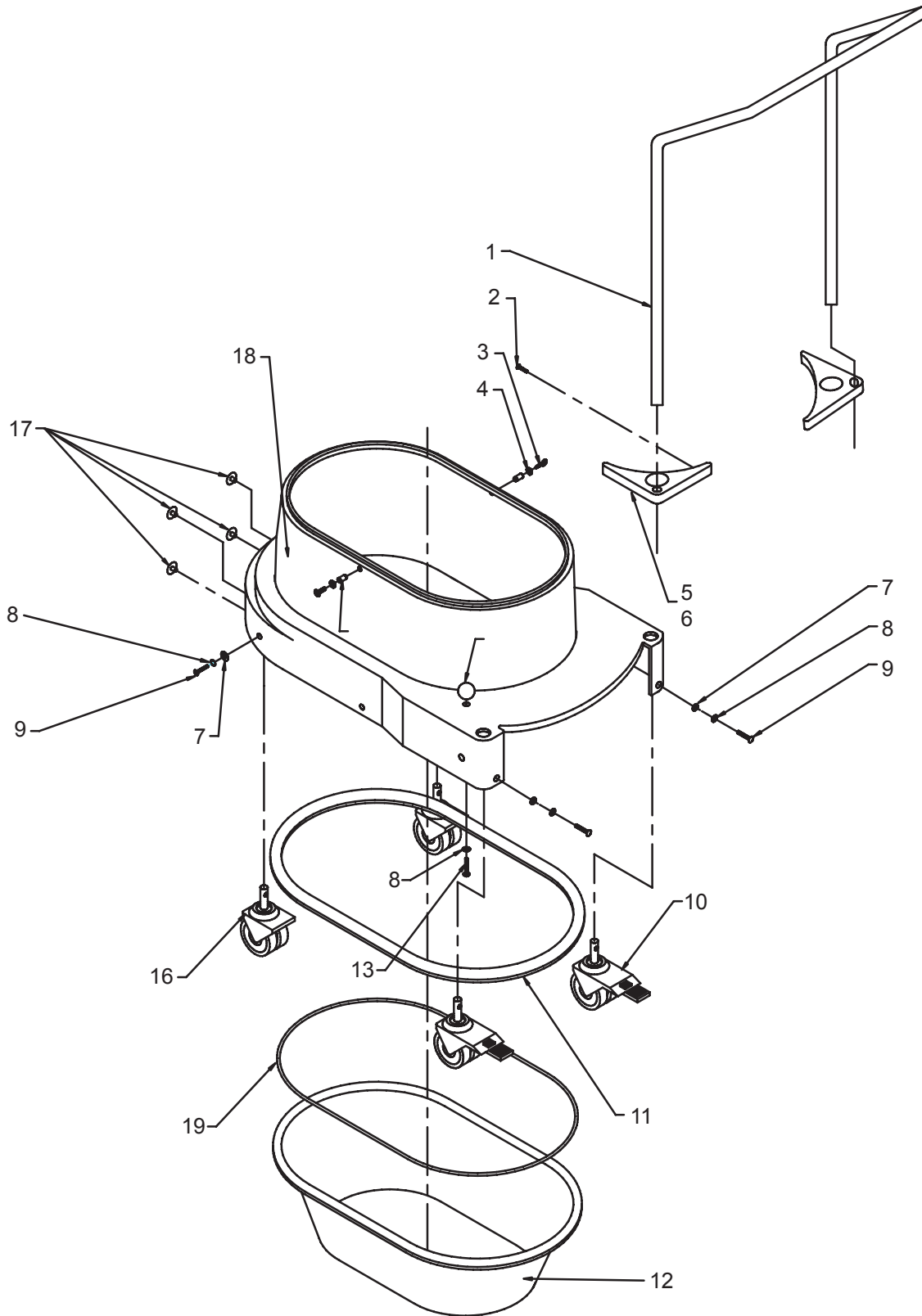



**PARTS LISTING - ILLUSTRATION #7 : BASE ASSEMBLY**

ITEM #	PART #	DESCRIPTION	QTY
1	ED25080	PUSH HANDLE	1
2	ED32988	#8 X 1 PHIL TRUSS HEAD, ZINC	4
3	ED3481701	M6X25 ALLEN HEAD SCREW	2
4	ED25000	1/4" STAR WASHER	2
5	ED32039	HANDLE SUPPORT, PLASTIC	2
6	ED34809	HANDLE SUPPORT, ALUMINUM	2
7	ED34882	M8 FLAT WASHER	4
8	ED25037	M8 WASHER	5
9	ED25054	M8 X 25 HEX BOLT	4
10	ED25085	DUAL CASTERS, FIXED, 75MM, W/STUD	2
11	ED20070	GASKET, DUST PAN/LOWER HOUSING, 20X15MM	1
12	ED34813	DUST PAN, 35LTR, RED	1
13	ED25038	M8 HEX CAP-1.25X20 ZINC	1
14	ED25060	KNOB, BLACK, 8MM	1
15	ED34817A	M6 BLIND PEM	2
16	ED25084	DOUBLE CASTERS, SWIVEL, 75MM	2
17	ED22120	PLUG, 8MM, BLACK	4
18	ED34808	LOWER HOUSING, RED	1
19	ED2509865	DUST PAN REPLACEMENT GASKET	1

# ILLUSTRATION #8 : DUST PAN LEVER ASSEMBLY

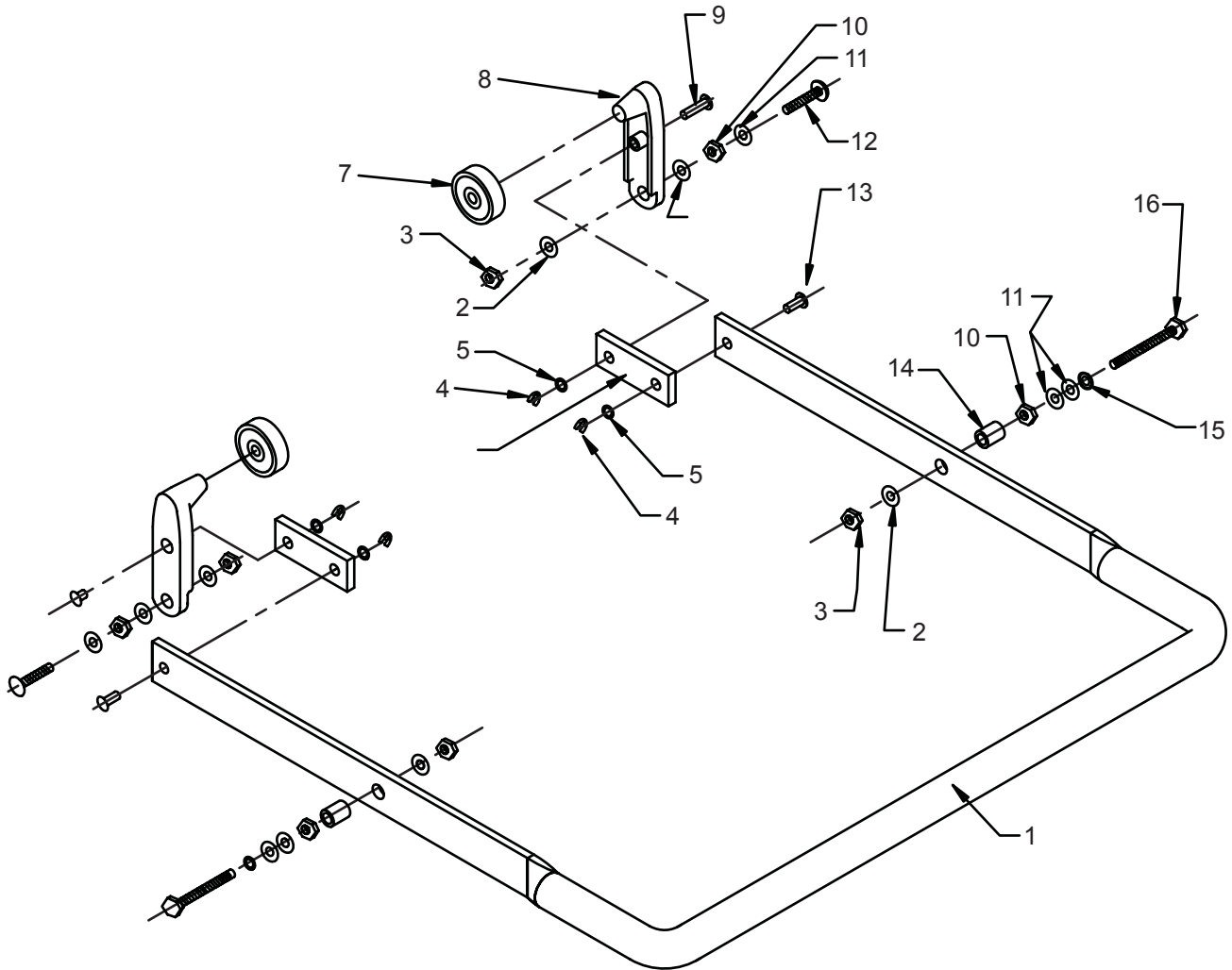

**PARTS LISTING - ILLUSTRATION #8 : DUST PAN LEVER ASSEMBLY**

ITEM #	PART #	DESCRIPTION	QTY
1	ED20010	FOOT LEVER	1
2	ED25061	M8 FLAT WASHER, ZINC	6
3	ED30029	M8 LOCK NUT	4
4	ED34923	C SPRING CLIP	4
5	ED25067	M6 FLAT WASHER	4
6	ED20027	FLAT STEEL PIVOT	2
7	ED34853	DUST PAN LEVER BEARING	2
8	ED34852	DUST PAN TENSION LEVER	2
9	ED34922	PIN,D=6X 19MM	2
10	ED20044	M8 HEX NUT -8	4
11	ED34882	M8 FLAT WASHER	6
12	ED25053	M8 X 35 CARRIAGE SCREW	2
13	ED34921	PIN D6X15	2
14	ED34812	SPACER FOR FOOT LEVER	2
15	ED25037	M8 WASHER, EXTERNAL	2
16	ED34811	M8 HEX BOLT, X 55-8.8	2

# ILLUSTRATION #9 : 50mm, 70mm & 100mm INLET ASSEMBLY

## 50mm

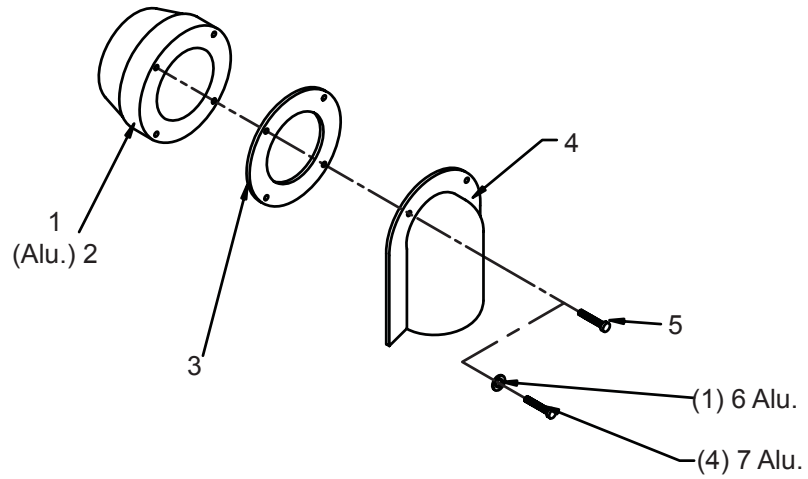

## 70mm

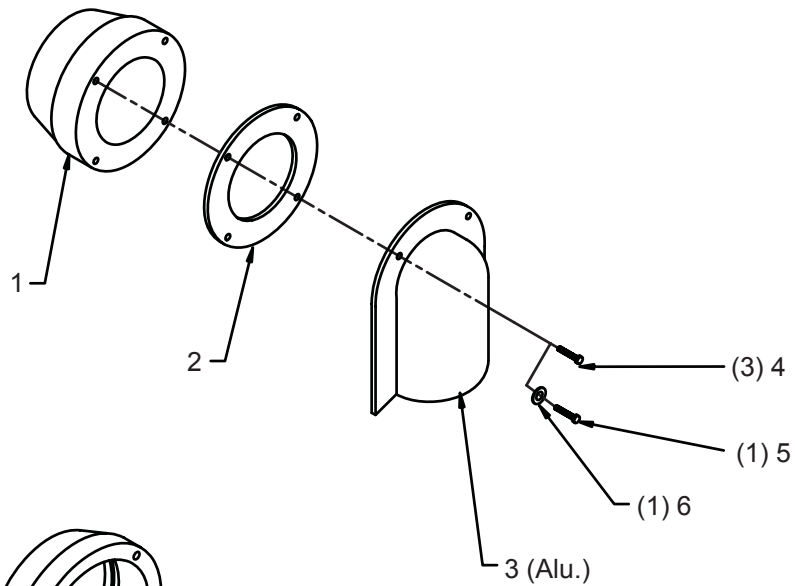

## 100mm

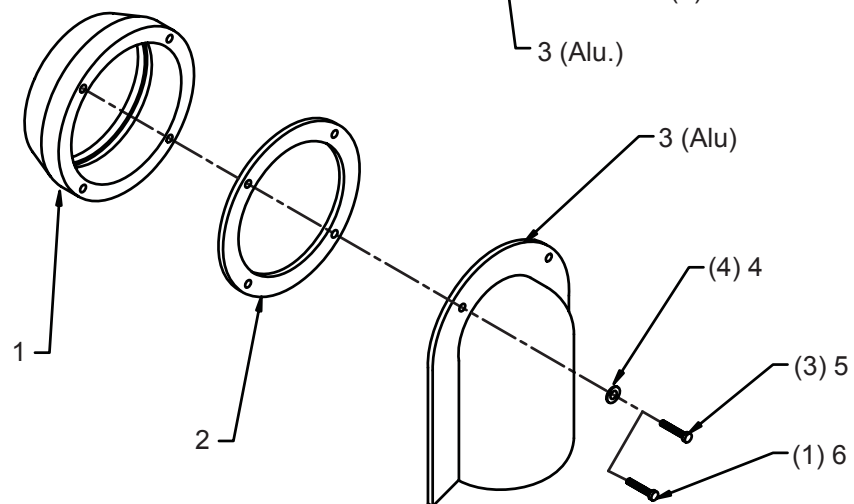

**PARTS LISTING - ILLUSTRATION #9 : 50mm INLET ASSEMBLY**

ITEM #	PART #	DESCRIPTION	QTY
1	ED31963	INLET, 50MM, GFK BLACK PLASTIC	1
2	ED20006	INLET, 50MM, ALUMINUM	1
3	ED34870	GASKET 50MM INLET	1
4	ED20021	INLET DEFLECTOR, 50MM, METAL	1
5	ED32988	#8 X 1 PHIL TRUSS HEAD, ZINC	4
6	ED20025	WASHER, STAR LOCKING, M4	1
7	ED25057	M4X20 SOCKET SCREW CAP	4

**PARTS LISTING - ILLUSTRATION #9 : 70mm INLET ASSEMBLY**

ITEM #	PART #	DESCRIPTION	QTY
1	ED30007	INLET, 70MM, ALUMINUM	1
2	ED34821	GASKET, 70MM INLET	1
3	ED30008	DEFLECTOR, 70MM, ALUMINUM	1
4	ED32866	M5-.8X30 SOCKET CAP, ALLEN HEAD	3
5	ED32863	M5-.8X20 SOCKET CAP SCREW	1
6	ED32867	32867 M5 EXT TOOTH LOCK WASHER ZINC	1

**PARTS LISTING - ILLUSTRATION #9 : 100mm INLET ASSEMBLY**

ITEM #	PART #	DESCRIPTION	QTY
1	ED35188	INLET, 100MM, ALUMINUM	1
2	ED34918	GASKET, 100MM INLET	1
3	ED35189	DEFLECTOR, 100MM, ALUMINUM	1
4	ED32867	M5 EXT TOOTH LOCK WASHER ZINC	4
5	ED32866	M5-.8X30 SOCKET CAP, ALLEN HEAD	3
6	ED32863	M5-.8X20 SOCKET CAP SCREW	1

**PARTS LISTING - ILLUSTRATION #10 : 2 & 3 INCH HOSE & ADAPTORS**

ITEM #	PART #	DESCRIPTION	QTY
1	ED501425-CON	2.00" x 25' w/(2) 2.00" rubber cuffs	25'
1	ED701225	3.00" x 25' w/(2) 2.75" rubber cuffs	25'
2	ED7018-BL	Hose Connector 3.00"	1
3	ED5220-BL	Hose Connector 2.00"	1

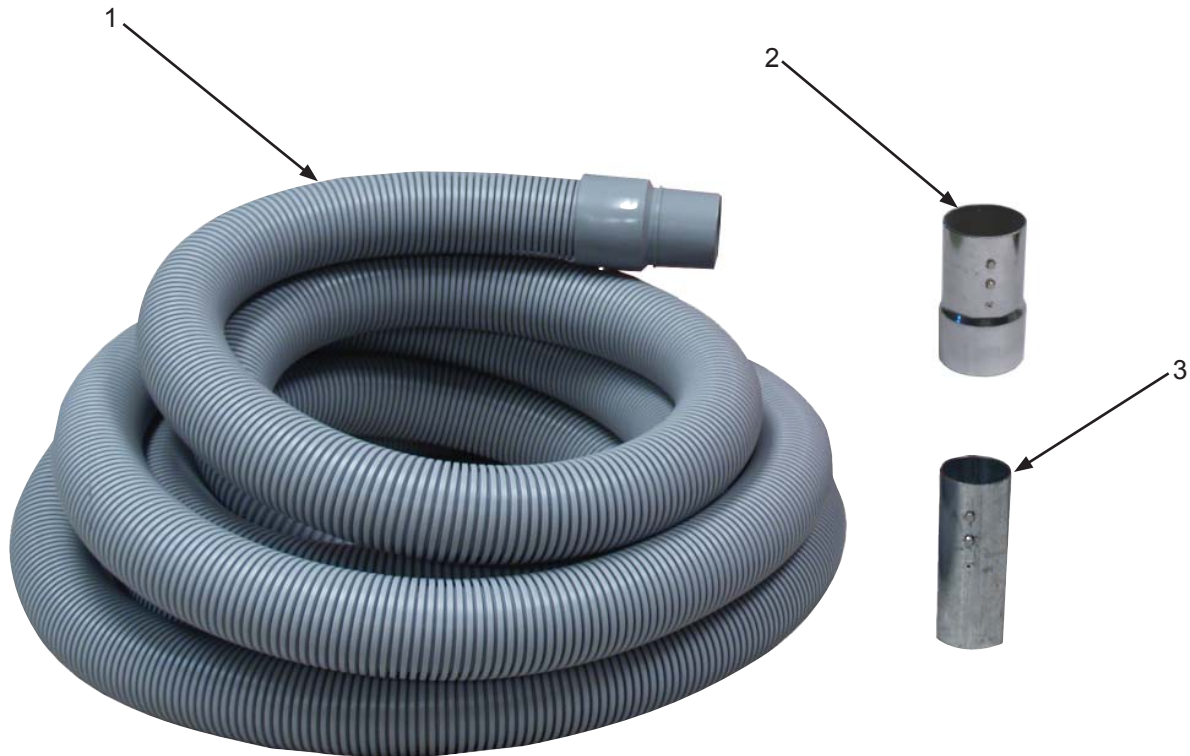

Page left blank intentionally

**LIMITED EQUIPMENT WARRANTY OF SALE – TERMS & CONDITIONS**

Equipment Development Company, Inc. herein referred to as EDCO (Seller) warrants that each new unit manufactured by EDCO to be free from defects in material and workmanship in normal use and service for a period of (1) one year (except for the cutter drum assembly on all model concrete/asphalt planes, in which case the warranty period shall be 90 days) from date of shipment to the original retail or equipment rental center owner.

Accessories or equipment furnished and installed on the product by EDCO but manufactured by others, including, but not limited to engines, motors, electrical components, transmissions etc., shall carry the accessory manufacturers own warranty.

EDCO will, at its option, repair or replace, at the EDCO factory or at a point designated by EDCO, any part which shall appear to the satisfaction of EDCO inspection to have been defective in material or workmanship.

EDCO reserves the right to modify, alter and improve any part or parts without incurring any obligation to replace any part or parts previously sold without such modified, altered or improved part or parts.

This warranty is in lieu of and excludes all other warranties, expressed, implied, statutory, or otherwise created under applicable law including, but not limited to the warranty of merchantability and the warranty of fitness for a particular purpose in no event shall seller or the manufacturer of the product be liable for special, incidental, or consequential damages, including loss of profits, whether or not caused by or resulting from the negligence of seller and/or the manufacturer of the product unless specifically provided herein. In addition, this warranty shall not apply to any products or portions thereof which have been subjected to abuse, misuse, improper installation, maintenance, or operation, electrical failure or abnormal conditions and to products which have been tampered with, altered, modified, repaired, reworked by anyone not approved by seller or used in any manner inconsistent with the provisions of the above or any instructions or specifications provided with or for the product

**FORCE MAJEURE**

Seller's obligation hereunder are subject to, and Seller shall not be held responsible for, any delay or failure to make delivery of all or any part of the Product due to labor difficulties, fires, casualties, accidents, acts of the elements, acts of God, transportation difficulties, delays by a common carrier, inability to obtain Product, materials or components or qualified labor sufficient to timely perform part of or all of the obligations contained in these terms and conditions, governmental regulations or actions, strikes, damage to or destruction in whole or part of manufacturing plant, riots, terrorist attacks or incidents, civil commotions, warlike conditions, flood, tidal waves, typhoon, hurricane, earthquake, lightning, explosion or any other causes, contingencies or circumstances within or without the United States not subject to the Seller's control which prevent or hinder the manufacture or delivery of the Products or make the fulfillment of these terms and conditions impracticable. In the event of the occurrence of any of the foregoing, at the option of Seller, Seller shall be excused from the performance under these Terms and Conditions, or the performance of the Seller shall be correspondingly extended.

This document sets forth the terms and conditions pursuant to which the purchaser ("Purchaser") will purchase and Equipment Development Co. Inc. ("Seller") will sell the products, accessories, attachments (collectively the Products) ordered by the Purchaser. These terms and conditions shall govern and apply to the sale of Seller's Products to Purchaser, regardless of any terms and conditions appearing on any purchase order or other forms submitted by Purchaser to Seller, or the inconsistency of any terms therein and herein.

**1. PRICE**

All prices set forth on any purchase order or other document are F.O.B. Sellers facility or distribution point, as may be determined by Seller (F.O.B. Point). All prices are exclusive of any and all taxes, including, but not limited to, excise, sales, use, property or transportation taxes related to the sale or use of the Products, now or hereafter imposed, together with all penalties and expenses. Purchaser shall be responsible for collecting and/or paying any and all such taxes, whether or not they are stated in any invoice for the Products. Unless otherwise specified herein, all prices are exclusive of inland transportation, freight, insurance and other costs and expenses relating to the shipment of the Products from the F.O.B. point to Purchaser's facility. Any prepayment by Seller of freight insurance and other costs shall be for the account of Purchaser and shall be repaid to Seller.

**2. PAYMENT TERMS**

Payment terms are as follows. 2% 10 days (to approved and qualified accounts). Net 30 days. This is a cash discount for invoices paid within 10 days after the invoice date, regardless of date of receipt of shipment. This is not a trade discount and will not be granted to accounts that do not adhere to stated terms.

\*All past due accounts are subject to a late payment fee of 1.5% per month or a maximum allowed by law if different, along with the expenses incidental to collection including reasonable attorney's fees and costs.

\*Seller reserves the right to hold shipments against past due accounts.

\*Seller reserves the right to alter payment terms.

**3. FREIGHT TERMS**

All shipments will be made F.O.B. shipping point as designated in these Terms and Conditions, and title shall pass at the F.O.B. point. Delivery to the initial common carrier shall constitute delivery to the Purchaser. Any claims for loss or damage during shipment are to be filed with carrier by the Purchaser. Seller will not assume responsibility for the performance of the carrier.

Back orders will be shipped in the most practical fashion with charges consistent with our freight policy established with the original order. UPS, FED EX, MAIL or shipments by other couriers are subject to the same terms and conditions as outlined in paragraph #3 "Freight Terms".

**4. DELIVERY, DAMAGES, SHORTAGES**

Seller shall use reasonable efforts to attempt to cause the Products to be delivered as provided for in these Terms & Conditions. Delivery to the initial common carrier shall constitute the delivery to the Purchaser. Seller's responsibility, in so far as transportation risks are concerned ceases upon the delivery of the Products in good condition to such carrier at the F.O.B. point and all the Products shall be shipped at the Purchaser's risk. Seller shall not be responsible or liable for any loss of income and/or profits, or incidental, special, consequential damages resulting from Seller's delayed performance in shipment and delivery.

**5. RETURN OF DEFECTIVE PRODUCTS**

Defective or failed material shall be held at the Purchaser's premises until authorization has been granted by Seller to return or dispose of Products. Products that are to be returned for final inspection must be returned Freight Prepaid in the most economical way. Credit will be issued for material found to be defective upon Seller's inspection based on prices at time of purchase.

**6. PRODUCTS ORDERED IN ERROR**

Products may be returned, provided that claim is made and Seller is notified within 7 days of receipt of Products, and the Products are in original buyer's possession not more than 30 days prior to return, subject to Seller's approval. If Products are accepted for return, they must be Freight Prepaid and buyer will be charged a minimum of 15% restocking charge, plus a charge back for outbound freight charges if the original order was shipped prepaid. Returns are not accepted for any Products that are specifically manufactured to meet the buyer's requirement of either specifications or quantity.

**AGREEMENTS**

These Terms and Conditions constitute the entire agreement between Seller and Purchaser as it relates to terms and conditions of sale, and supersedes any and all prior oral or written agreements, correspondence, quotations or understandings heretofore in force between the parties relating to the subject matter hereof. There are no agreements between Seller and Purchaser with respect to the Product herein except those specifically set forth in and made part of these terms and conditions. Any additional terms, conditions and/or prices are rejected by Seller.

These terms and conditions may be modified, cancelled or rescinded only by a written agreement of both parties executed by their duly authorized agents.

**USE ONLY GENUINE EDCO PARTS & ACCESSORIES**  
**For your own safety, the safety of others and the life of your machine.**

**Equipment Development Company, Inc.**

