



**POWER TOOLS™**

*No Dust. No Water. No Problem.*

**iQ360x® - Dust Control Chop Saw**

**Parts Manual**

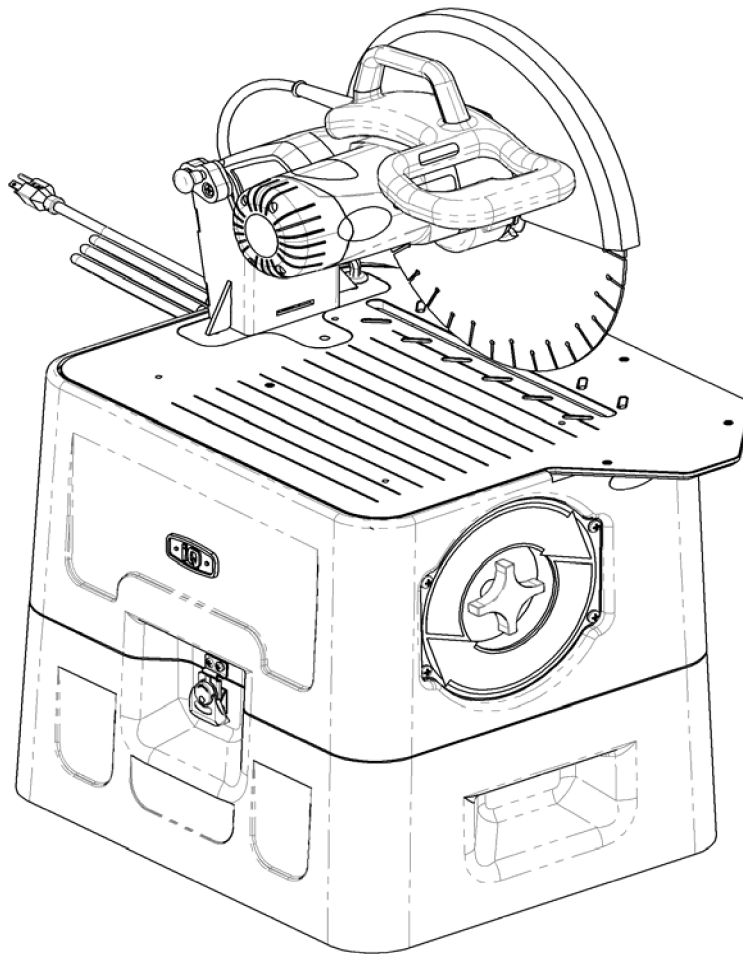

# CUTTING HEAD

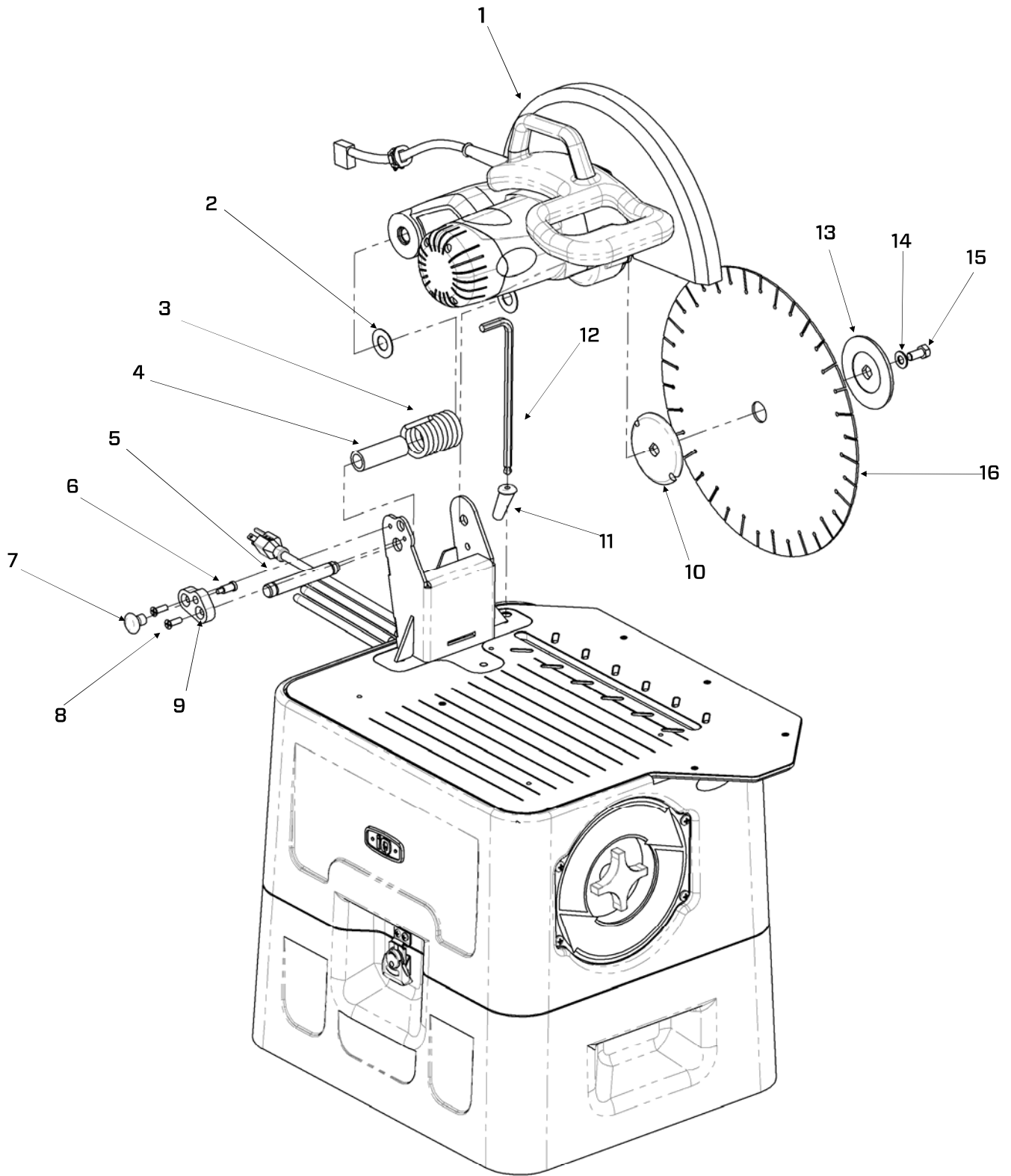

## CUTTING HEAD

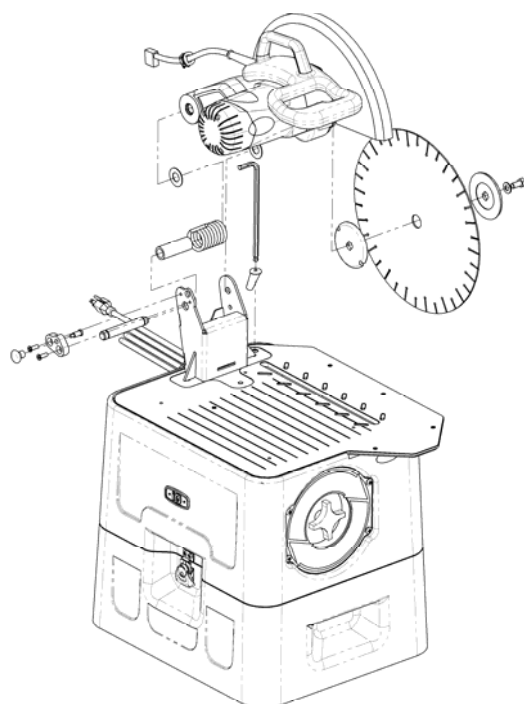

ITEM NO.	QTY	PART NO.	DESCRIPTION
1	1	0360-62002-01	120v Saw Motor
2	2	0360-62059-01	Brass Washer
3	1	0360-62056-01	Torsion Spring
4	1	0360-62055-01	Sheath
5	1	0360-62058-01	Saw Mount Shaft
6	1	0360-62053-01	Lock Pin
7	1	0360-62054-01	Lock Pin Knob
8	2	0360-01054-01	Flat Head Screw, 1/4"-20
9	1	0360-00131-01	Shaft Retainer Plate
10	1	0360-00136-01	Inner Thrust Washer
11	1	0360-62052-01	Rubber Sleeve
12	1	0360-62051-01	Blade Allen Wrench
13	1	0360-00135-01	Outer Thrust Washer
14	1	0360-62066-01	Cone Washer
15	1	0360-62057-01	M10x25 Bolt
16	1	MAS14-125AG	Masonry Blade 14"x.125—Gold

# MAIN HOUSING

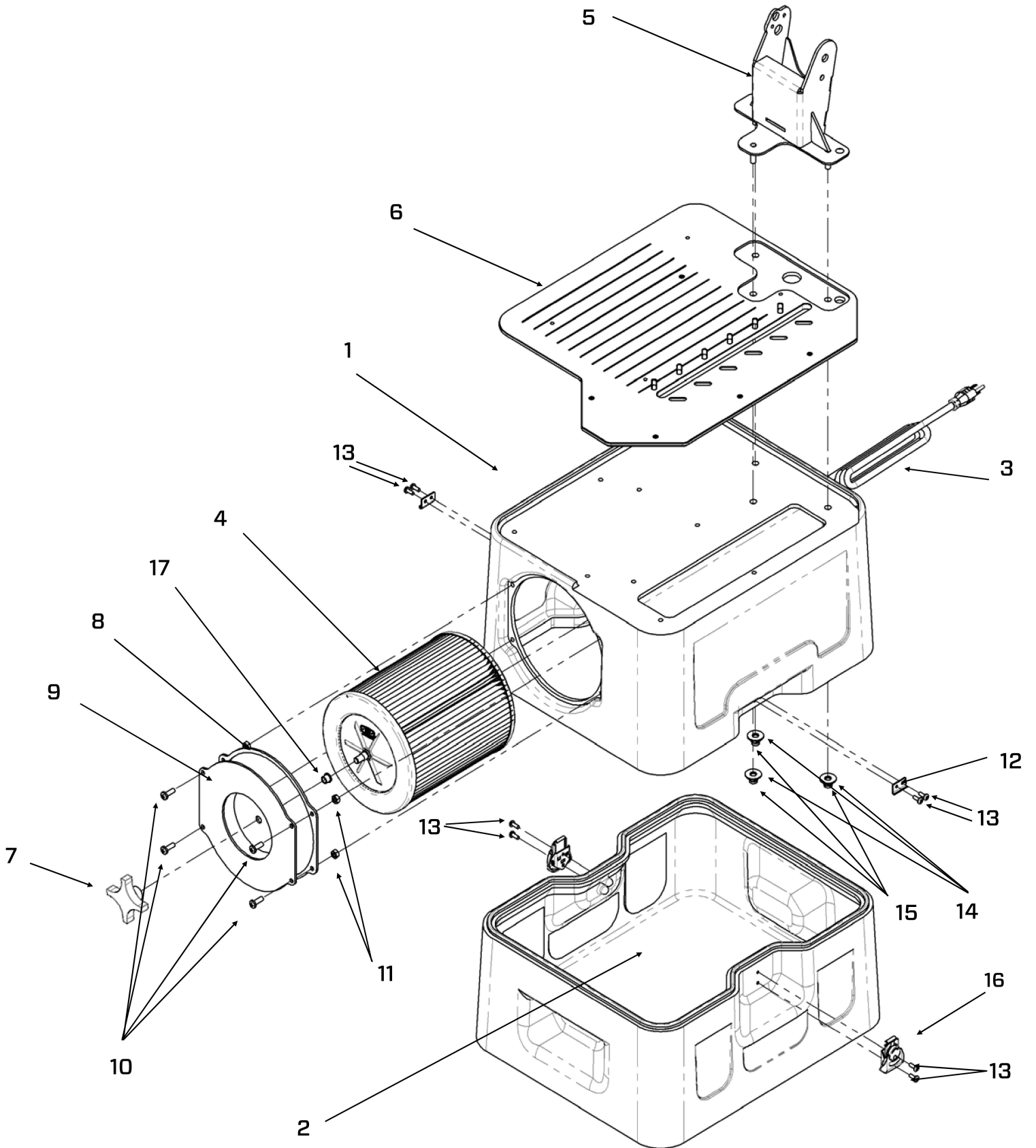



## MAIN HOUSING

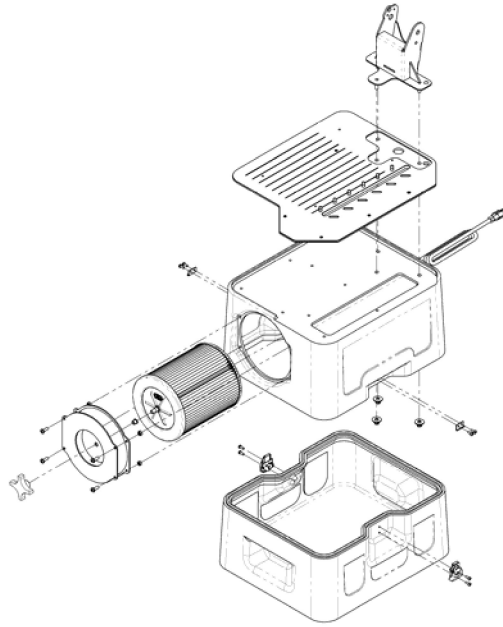

ITEM NO.	QTY	PART NO.	DESCRIPTION
1	1	0360-00002-01	Vacuum Upper Housing
2	1	0360-00003-01	Dust Collection Tub
3	1	0360-60001-01	Power Cord
4	1	0360-67001	Vacuum Filter
5	1	0360-00130-01	Saw Mount
6	1	0360-00121-01	Top Deck
7	1	0360-08019-01	Filter Spin Handle
8	26"	0360-07003-01	Foam Rubber Seal
9	1	0360-00122-01	Filter Access Panel
10	4	0360-01014-01	Screw 1/4"-20
11	4	0360-10009-01	Nylock nut 1/4"-20
12	2	0360-08002-01	Draw Catch
13	8	0360-01008-01	Screw 8-32
14	3	0360-02005-01	Large Flat Washer
15	3	0360-03002-01	Nylock nut 5/16"-18
16	2	0360-08001-01	Rotary-Draw Latch
17	1	0360-68002-01	Flange Sleeve Bearing

VACUUM HOUSING

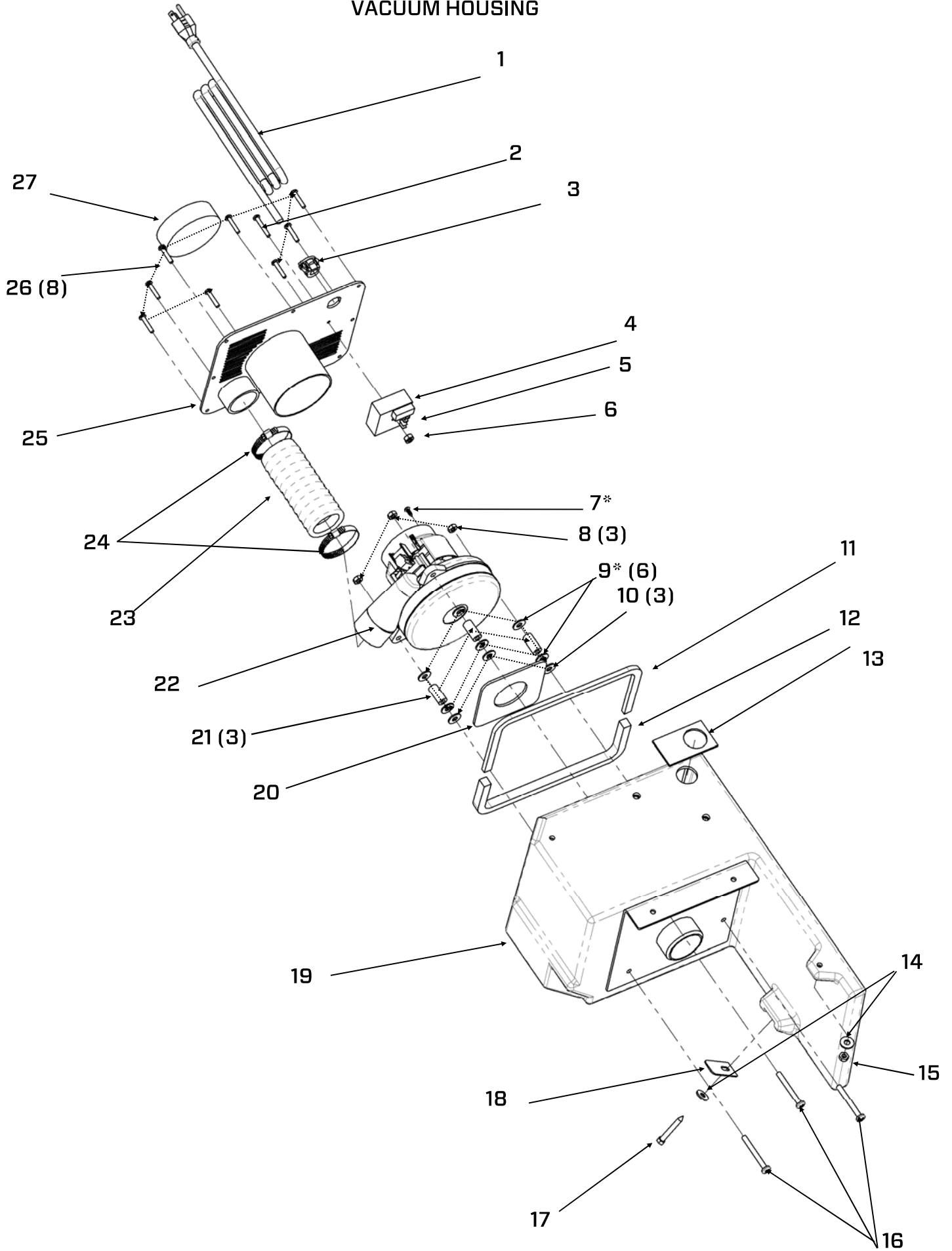

## VACUUM HOUSING

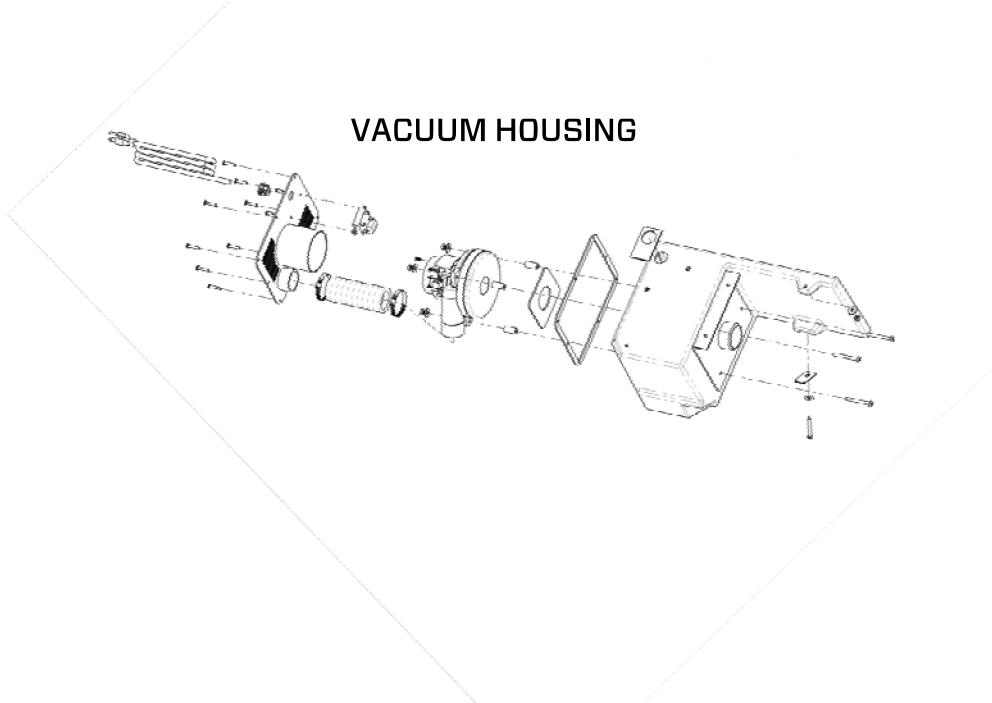

ITEM NO.	QTY	PART NO.	DESCRIPTION
1	1	0360-60001-01	Power Cord
2	1	0360-01013-01	Screw, 8-32
3	1	0360-60003-01	Cord Grip
4	1	0360-61002-01	Relay
5	1	0360-02006-01	Washer
6	1	0360-03005-01	Nylock 8-32
7	1	0360-01022-01	Self tap screw(*Deleted after SN# iQ360v2-2030 & for replacement Vacuum Motors)
8	3	0360-03001-01	Nylock nut 1/4"-20
9	6	0360-02002-01	Washer (*Deleted after SN# iQ360v2-2030 & for replacement Vacuum Motors)
10	3	0360-02001-01	Rubber Washer
11	18.5"	0360-07004-01	Top Seal
12	12.5"	0360-07005-01	Bottom Seal
13	2"	0360-07019-01	Foam Seal 1/8
14	7	0360-02004-01	Large Washer
15	9	0360-03003-01	Nylock nut 1/4"-28
16	3	0360-04001-01	Hex Head Cap Screw 1/4"-20
17	1	0360-01010-01	Pan Head Screw 1/4"-20
18	1	0360-00004-01	Filter Agitator Strip
19	1	0360-00001-01	Vacuum Motor Housing-Inside Box
20	4"	0360-07001-01	Foam Seal
21	3	0360-06001-01	Round Spacer
22	1	0360-62001-01	Vacuum Motor
23	11.5"	0360-09002-01	Vacuum Hose
24	2	0360-09001-01	Hose Clamp
25	1	0360-00123-01	Rear Access Panel
26	8	0360-01007-01	Screw #8
27	1	0360-67002-01	Vacuum Motor Filter (@Rear Access Panel)

# VACUUM HOUSING TO MAIN HOUSING

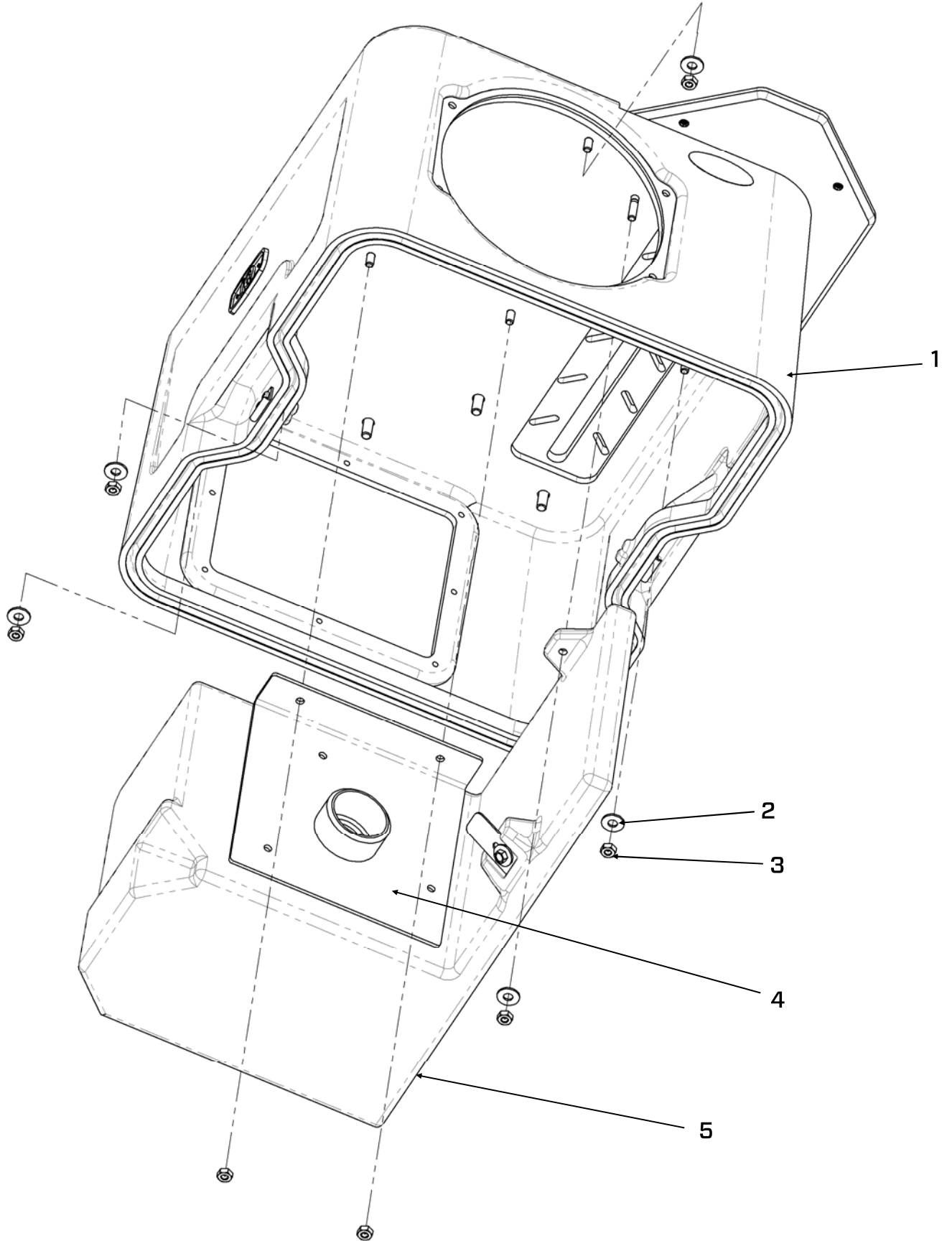

## VACUUM HOUSING TO MAIN HOUSING

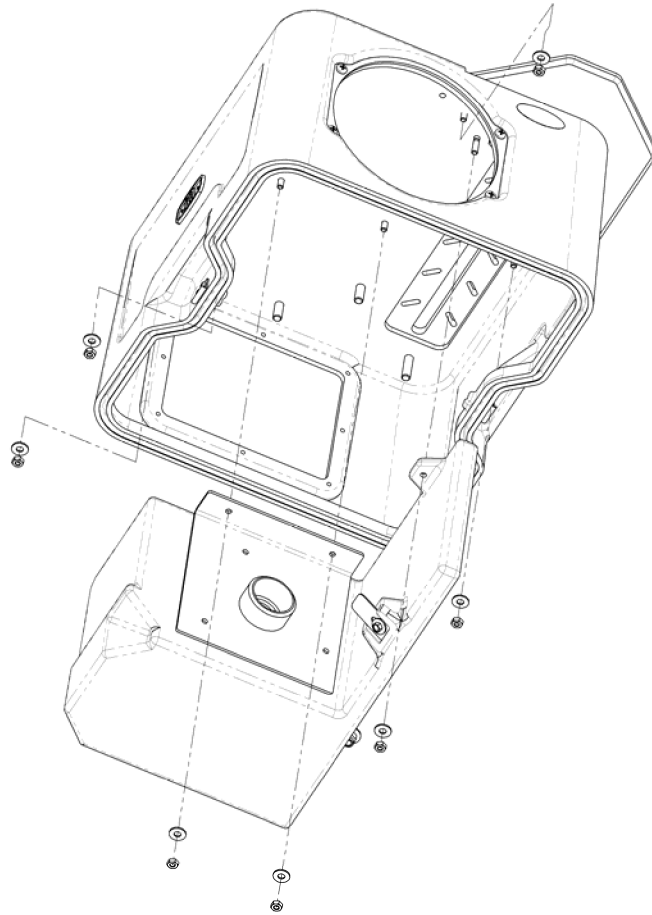

ITEM NO.	QTY	PART NO	DESCRIPTION
1	1	0360-00002-01	Vacuum Housing Upper
2	7	0360-02004-01	Large-Diameter Flat Washer
3	9	0360-03003-01	Nylock nut 1/4"-28
4	1	0360-00124-01	Bulkhead Assembly
5	1	0360-00001-01	Vacuum Motor Housing—Inside Box

# REAR ACCESS PANEL / WIRING DIAGRAM

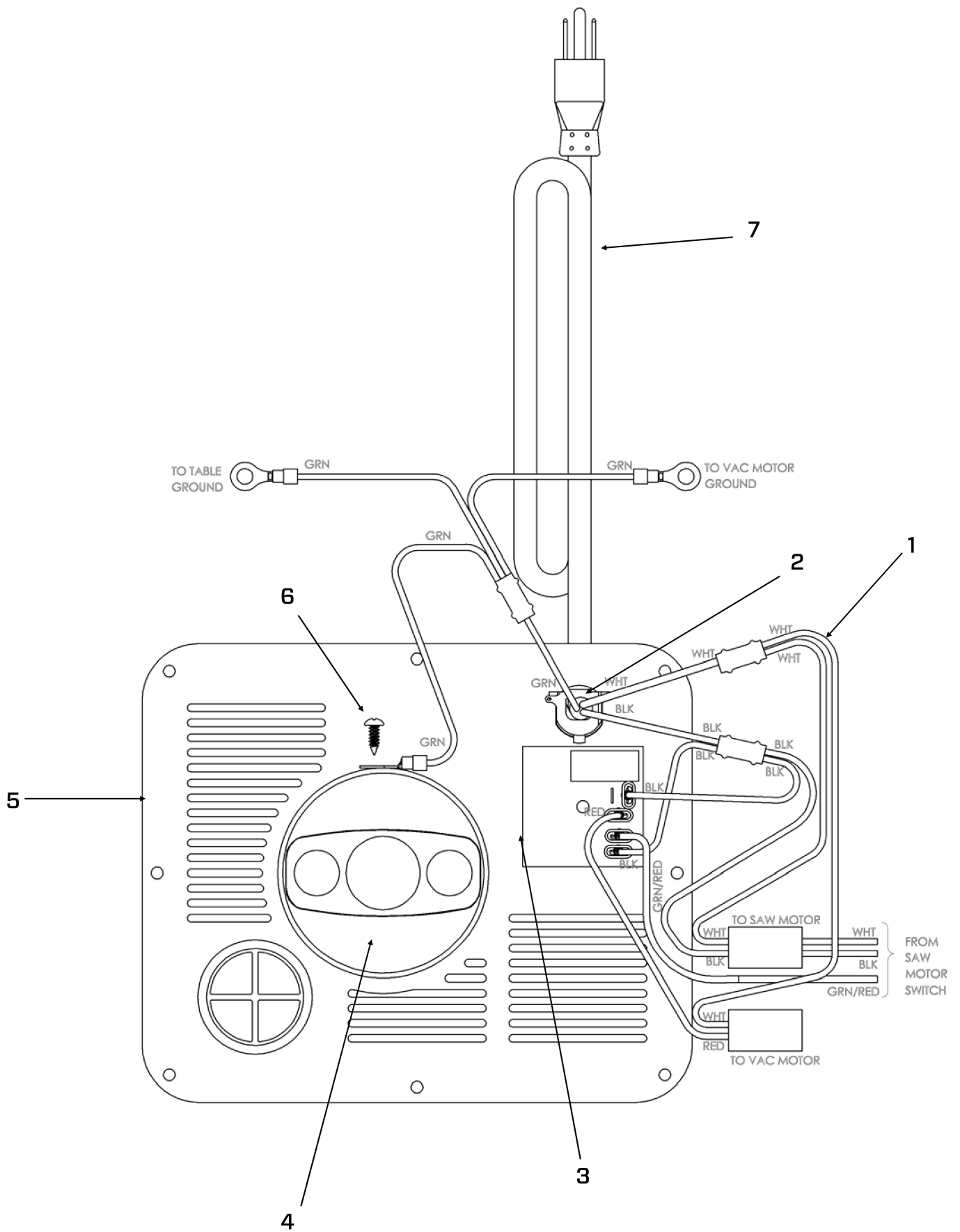

## REAR ACCESS PANEL / WIRING DIAGRAM

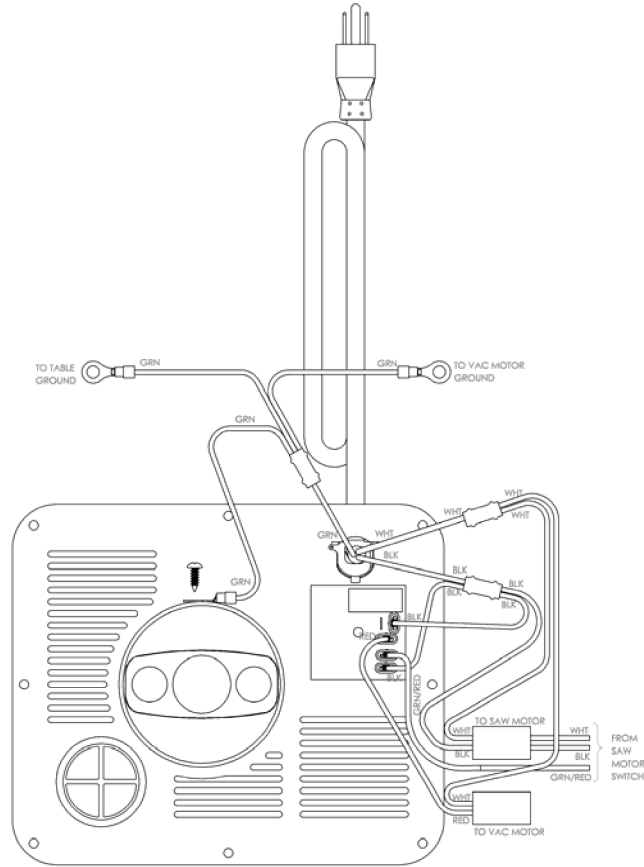

ITEM NO.	QTY	PART NO.	DESCRIPTION
1	1	0360-60004-01	Wiring Harness
2	1	0360-60003-01	Cord Grip
3	1	0360-61002-01	Relay
4	1	0360-67002-01	Vacuum Motor Filter (@ Rear Access Panel)
5	1	0360-00123-01	Rear Access Panel
6	1	0360-01023-01	Screws #8
7	1	0360-60001-01	Power Cord

# MOTOR GEAR HOUSING

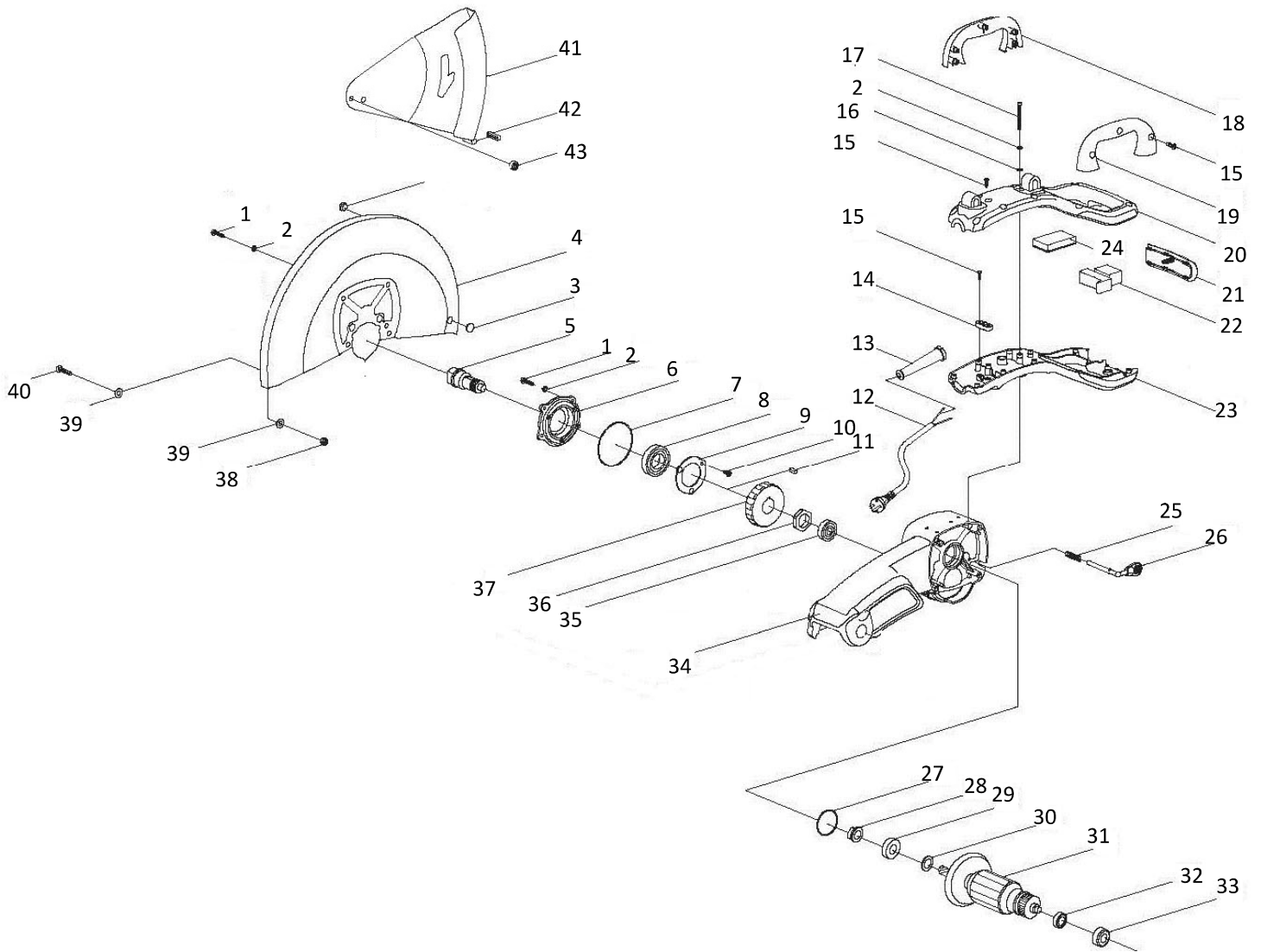



## MOTOR GEAR HOUSING

ITEM NO.	QTY	PART NO.	DESCRIPTION
1	4	0360-62023-01	Bolt M5 x 30
2	15	0360-62022-01	Washer M5
3	2	0360-62008-01	Rubber Plug
4	1	0360-62007-01	Blade Guard
5	1	0360-62009-01	Blade Shaft
6	1	0360-62012-01	Bearing Holder
7	1	0360-62013-01	O-Ring
8	1	0360-62014-01	Bearing
9	1	0360-62015-01	Bearing Washer
10	3	0360-62016-01	Bolt M4 x 12
11	1	0360-62017-01	Key
12	1	0360-62018-01	Power Cable
13	1	0360-62019-01	Power Cable Armor
14	1	0360-62020-01	Power Cable Clamp
15	17	0360-62021-01	Screw
16	7	0360-62011-01	Washer M5
17	4	0360-62010-01	Bolt M5 x 16
18	1	0360-62024-01	Right Handle
19	1	0360-62025-01	Left Handle
20	1	0360-62026-01	Upside Grip
21	1	0360-62027-01	Soft Grip Cover
22	1	0360-62028-01	ON-OFF Switch w/locking but-
23	1	0360-62029-01	Downside Grip
24	1	0360-62069-01	Foam Pad
25	1	0360-62030-01	Spring
26	1	0360-62031-01	Blade Lock Trigger
27	1	0360-62032-01	O-Ring 34.5 x 2.65
28	1	0360-62033-01	Oil-Seal Sheath
29	1	0360-62034-01	Bearing 6202-2Z/C
30	1	0360-62035-01	Washer
31	1	0360-62036-01	Armature
32	4	0360-62037-01	Bearing 609-2Z/C4
33	1	0360-00134-01	Rubber Bearing Sleeve
34	1	0360-62060-01	Gear Housing
35	1	0360-62061-01	Bearing 6200-2Z
36	1	0360-62062-01	Nut
37	1	0360-62063-01	Drive Gear
38	2	0360-03006-01	Nut M6
39	4	0360-02007-01	Washer M6
40	2	0360-04002-01	Bolt M6x20
41	1	0360-09008-01	Rotating Blade Guard
42	1	0360-07006-01	Plastic Bumper
43	2	0360-62072-01	Spacer Sleeve

MOTOR HOUSING

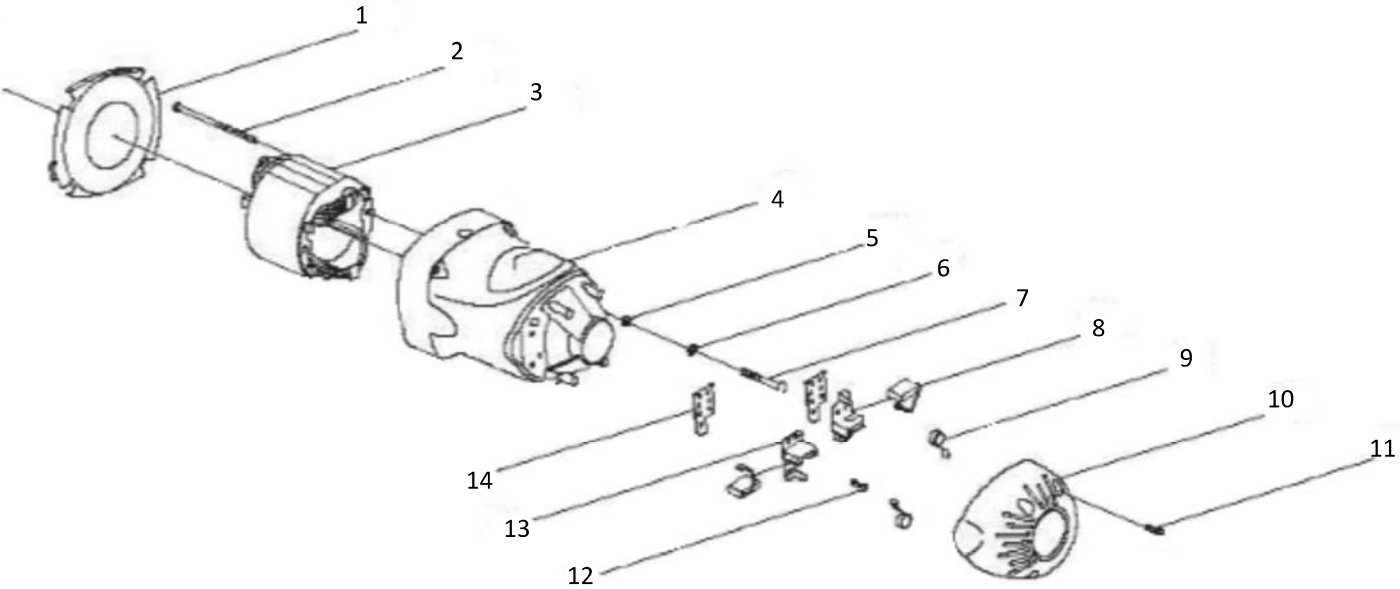

## MOTOR HOUSING

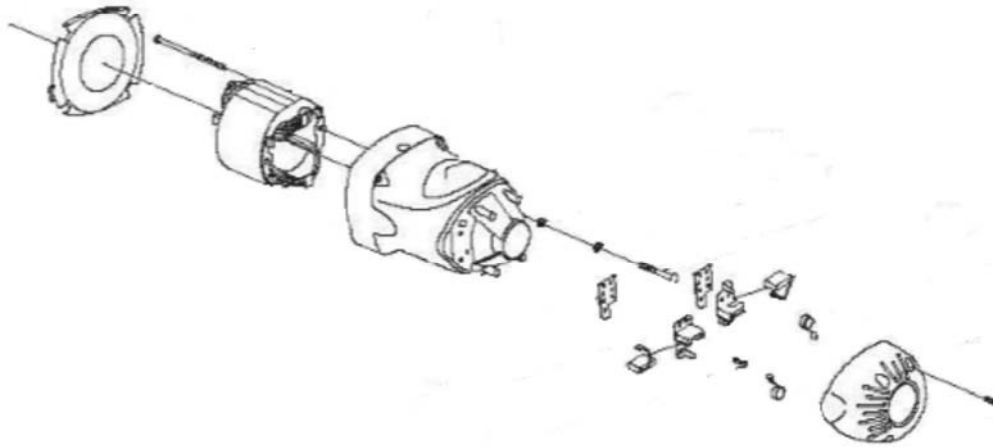

ITEM NO.	QTY	PART NO.	DESCRIPTION
1	1	0360-62039-01	Fan Guide
2	2	0360-62040-01	Screw
3	1	0360-62041-01	Stator
4	1	0360-62043-01	Motor Housing
5	7	0360-62011-01	Washer M5
6	15	0360-62022-01	Washer M5
7	6	0360-62044-01	Bolt M5 x 50
8	2	0360-62046-02	Carbon Brush
9	2	0360-62030-01	Spring
10	1	0360-62048-01	Brush Cover
11	17	0360-62021-01	Screw
12	6	0360-62049-01	Screw
13	2	0360-62050-01	Brush Holder
14	2	0360-62068-01	Mount Plate



**POWER TOOLS™**

*No Dust. No Water. No Problem:*

## **iQ Power Tools™ Limited Warranty**

New equipment sold by iQ Power Tools™ or an iQ™ authorized dealer is warranted to be free from manufacturing defects in normal service for a period of one (1) year from date of purchase by the original consumer purchaser. Warranty period for rental items is 90 days.

All iQ™ products must be registered either through our website or by mailing in the Warranty Card in order for the warranty to be active and valid. This Warranty shall not apply to any parts that have been subjected to misuse or improper service, damaged in transit or handling, altered or repaired by unauthorized representatives, or used with a blade that is not recommended by iQ Power Tools™ .

Any claim arising under this Warranty must be submitted by the original purchaser within the Warranty period specified above and must include proof of purchase. Within Warranty period, options are either to replace or repair any parts or components that are found to be defective by iQ Power Tools™ at no charge to the original purchaser. iQ Power Tools™ shall not be responsible or obligated to pay for freight or other transportation-related costs or expenses in connection with any defective products, replacements, or components that are returned to iQ Power Tools™ facility or any authorized repair station.

Parts and labor needed to maintain products, and the replacement of components due to normal wear and tear, are the purchaser's responsibility and are not covered by this Warranty. All products or components replaced under Warranty become the property of the manufacturer. All replacement parts will be considered to be part of the original product and any Warranty on such parts will expire concurrently with this original Warranty.

iQ Power Tools™ will pay for parts and labor in connection with Warranty repairs conducted by iQ Power Tools™ or its authorized repair center. Replacement parts installed by anyone

**P.O. Box 7449**

**Moreno Valley, CA 92552**

**Tel: 888-274-7744 Fax (951) 571-9708**

**[www.iqpowertools.com](http://www.iqpowertools.com)**



**POWER TOOLS™**

*No Dust. No Water. No Problem.™*

P.O. Box 7449

Moreno Valley, CA 92552

Tel: 888-274-7744 Fax (951) 571-9708

[www.iqpowertools.com](http://www.iqpowertools.com)