



IMPORTANT MIXING INSTRUCTIONS

AGGREGATE BIGGER THAN 3/8" WILL DAMAGE MIXER

SAND LIME CEMENT	PRE - MIX 60 lb SPEC - MIX 80 lb	SILO
Set up mixer Start mixer Do not add water 1. Add 1/4 sand 2. Add lime 3. Add water slowly 4. Add 1 bag cement 5. Add 1/4 sand 6. Repeat operations sand/cement 7. Check water 8. Mix up thoroughly	Set up mixer Start mixer Do not add water 1. Check bag weight 2. Determinate max load 3. Add 1/2 of max load 4. Add 3/4 of water 5. Add rest of bags 6. Mix up thoroughly	Set up mixer Start mixer Do not add water 1. Add 1/2 of max load 2. Add 3/4 of water 3. Add rest of material 4. Add rest of water 5. Mix up thoroughly

MIXER DRUM CAPACITY

120:4.5 CUBIC FEET (250 lbs)*

240:9 CUBIC FEET (400 lbs)*

360:13 CUBIC FEET (700 lbs)*

750:27 CUBIC FEET (1700 lbs)*

* WEIGHT IS COMBINED SAND, LIME, AND CEMENT MIXTURE

Contents

IMER U.S.A., INC. INSTRUCTION MANUAL MORTARMAN® 750 MBP

NOTE:Please read this manual before beginning to assemble or operate this piece of equipment.

ASSEMBLY.....	4
LIFTING TO MAXIMUM HEIGHT.....	5
IMPORTANT NOTES AND ADVICE.....	7
OPERATING INSTRUCTIONS.....	9
MAINTENANCE.....	10
TECHNICAL SPECIFICATIONS.....	11
WIRING DIAGRAM.....	12
SPARE PARTS LIST.....	13

ASSEMBLY

Essentially the Mortarman® 750 MBP is fully assembled and ready to operate when it leaves the assembly facility here at **IMER U.S.A.** However there are a couple items which should always be checked before towing and operating the Mortarman® 750 MBP.

1. Retrieve the dump handle from inside the drum and thread it into the dump gate mechanism.
2. Make sure each tire is inflated to 40 lbs. PSI.
3. Make certain the retractable stability legs are raised up fully and locked in place with the anchor pin and safety clips provided.
4. Make certain that the tow bar is properly anchored and its tow chain is in place. It is also important to loop the tow chain around the tow bar several times before connecting it to the vehicle.
5. Make sure the engine canopy door is latched shut.
6. Make certain that the hitch system on your car or truck is compatible to the tow bar tongue.
7. Finally, local laws and ordinances vary from state to state regarding the registration of towable construction equipment.
Check with your local Department of Motor Vehicles for the proper procedure to follow.

NOTE: State law may also require a tail light assembly.

LIFTING THE MACHINE TO THE MAXIMUM UNLOADING HEIGHT

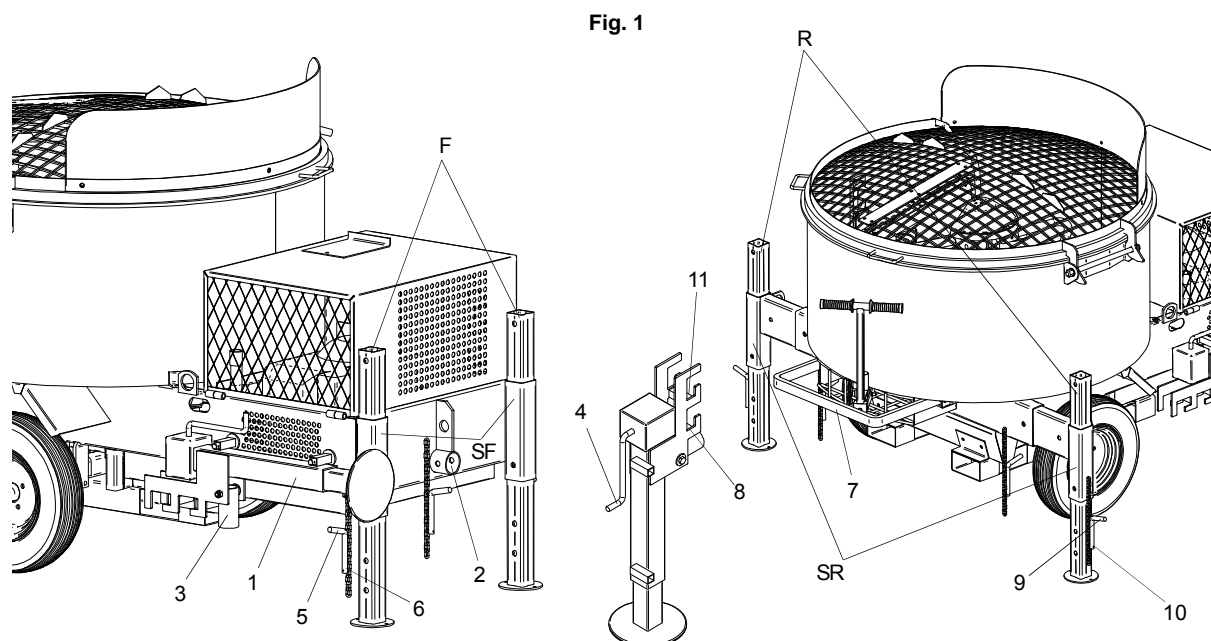

CAUTION: Make sure the lift jack is on a solid flat surface before beginning to raise the machine. Additionally, NEVER work on or around the Mortarman® 750 MBP while the jack stand is holding it up.....Serious injury can result!

- 1) Extract the lifting foot [1] (fig. 1) from the lateral housing.
- 2) Position the lifting foot in front of the drive hole [2] located on the engine side of the machine (front), and lower the foot [1] until pin [3] is aligned with hole [2], by means of the handwheel [4].
- 3) Insert pin [3] in the drive hole [2] and turn handwheel [4] to raise the machine until the front legs [F] are detached from the ground.
- 4) Remove locking pins [5] of legs [F], removing the relative cotter pins [6], to lower the legs to the ground.
- 5) Turn handwheel [4] again to raise the machine to the maximum height, ensuring that the hole on the leg supports (SF) is aligned with the 4th hole (starting from the bottom) on each leg [F].
- 6) Insert locking pins [5] and secure in position by means of cotter pins [6].
- 7) Remove the lifting foot [1] and position it on the other side of the machine (rear), in the vicinity of the roll bar [7].
- 8) Lower the lifting foot [1] until the lower bracket [8] can be inserted below the roll bar [7] and centred.
- 9) Raise the machine by means of the handwheel [4], so that the rear legs [R] no longer touch the ground.
- 10) Remove locking pins [9] of legs [R], removing the relative cotter pins [10], to lower the legs to the ground.
- 11) Turn handwheel [4] again to raise the machine until the hole on the leg supports (SR) is aligned with the 4th hole (starting from the bottom) on each leg [R].
- 12) Insert locking pins [9] and secure in position by means of cotter pins [10].
- 13) Remove the lifting foot [1] and use the handwheel [4] to lower the machine until the upper bracket [11] can be inserted below the roll bar [7] and centred.
- 14) Raise the machine by means of the handwheel [4], so that the rear legs [R] no longer touch the ground.
- 15) Remove locking pins [9] of legs [R], removing the relative cotter pins [10], to lower the legs to the ground.
- 16) Turn handwheel [4] again to raise the machine until the hole on the leg supports (SR) is aligned with the 5th hole (starting from the bottom) on each leg [R].
- 17) Insert locking pins [9] and secure in position by means of cotter pins [10].
- 18) Remove the lifting foot [1] and return to the lateral housing.

To lower the machine, proceed as follows:

- 1) Extract the lifting foot [1] (fig. 1) from the lateral housing.
- 2) Remove the lifting foot [1] and position it on the rear side of the machine, in the vicinity of the roll bar [7].
- 3) Raise the lifting foot [1] by means of the handwheel [4] until the upper bracket [11] can be inserted below the roll bar [7] and centred.
- 4) Turn the handwheel [4] again so that the rear legs [R] no longer touch the ground.
- 5) Remove leg locking pins [10], removing the relative cotter pins [9], to lower the legs [R] to the ground.
- 6) Turn handwheel [4] again to lower the machine until the hole on the leg supports (SR) is aligned with the 4th hole (starting from the bottom) on each leg [R].
- 7) Insert locking pins [9] and secure in position by means of cotter pins [10].
- 8) Remove the lifting foot [1] and use the handwheel [4] to lower the machine until the lower bracket [8] can be inserted below the roll bar [7] and centred.
- 9) Turn the handwheel [4] again so that the rear legs [R] no longer touch the ground.
- 10) Remove leg locking pins [9], removing the relative cotter pins [10], to lower the legs [R] to the ground.
- 11) Turn handwheel [4] again to lower the machine until the hole on the leg supports (SR) is aligned with the 3rd hole (starting from the bottom) on each leg [R].
- 12) Insert locking pins [9] and secure in position by means of cotter pins [10].
- 13) Remove the lifting foot [1] and position on the other side of the machine (front) in front of the drive hole [2] and lower the foot [1] until pin [3] is aligned with hole [2], by means of the handwheel [4].
- 14) Insert pin [3] in the drive hole and turn handwheel [4] to raise the machine until the front legs [F] are detached from the ground.
- 15) Remove locking pins [5] of legs [F], removing the relative cotter pins [6], to lower the legs to the ground.
- 16) Turn handwheel [4] again to lower the machine until the hole on the leg supports (SR) is aligned with the 3rd hole (starting from the bottom) on each leg [F].
- 17) Insert locking pins [5] and secure in position by means of cotter pins [6].
- 18) Remove the lifting foot [1] and return to the lateral housing.

IMPORTANT NOTES AND ADVICE

Do's and Don'ts on the Safe Use of the Mortarman® 750

In the interest of safety, whoever uses or maintains the MORTARMAN® 750 should first read this manual and become familiar with all of the important safety notes. Failure to follow this advice may result in injury to yourself and others.

WHAT TO DO !

- Carefully read and understand these instructions before operating the mixer.
- Always turn off the engine and disconnect the spark plug wire before cleaning or maintaining the mixer. Mixes powered by electric motors should be unplugged from their power source before servicing is performed.
- Make sure the safety guards are always in place.
- When using the machine always wear safety boots with reinforced toe-caps, safety glasses, gloves, hard hat, and clothing with the appropriate fit.
- Practice starting and stopping the machine.
- Keep the mixer clean and free of debris build-up.
- Periodically inspect your mixer for abnormal wear or damage.
- **Always stop the engine before adding fuel.**
- Whenever the mixer begins to sound or run in an unusual manner..... **STOP THE MACHINE !....** and do not re-start the mixer until the difficulty is understood and repaired.



IMPORTANT NOTES AND ADVICE

What NOT TO DO !

DO NOT

- place your hands or any other object inside the mixer drum while it is running.

DO NOT

- place any tools or other objects in or around the mixer drum while it is running.

DO NOT

- operate the mixer on a surface that is UNEVEN.. .. if the MORTARMAN® 750 is placed on an incline, it can fall over or roll away!

DO NOT

- clean, assemble or work on the mixer while it is plugged in, or while the spark plug wire is connected to the spark plug!

DO NOT

- operated the mixer in or around water puddles!

DO NOT

- leave the mixer unattended!

DO NOT

- use the safety grate interlock switch for stopping the mixer.....shut off the motor.....this safety interlock system is designed to provide some protection for negligent operators.**REMEMBER**, never raise the safety grate while the mixer is running, unplug the mixer from its power source, then the grate may be raised properly.

DO NOT

- allow other persons around the mixer while it is operating.

DO NOT

- operate the MORTARMAN® 750 if you are uncertain as to how to run the machine.... Contact your local **IMER DISTRIBUTOR** or call **IMER U.S.A. at (800) 275-5463.**

NOTE: These safety instructions are simple and straight forward.....FOLLOW THEM!

***WE WANT SAFE AND EFFICIENT
PRODUCTION/OPERATION
FOR ALL OUR CUSTOMERS!***

OPERATING INSTRUCTIONS

1. Before starting the engine read the Honda manual provided and become familiar with the GXV 390 powerplant.
2. Place the MORTARMAN® 750 at the appropriate working height. The working height is determined by which type of container the material mixed is to be discharged into:

For Example : Wheelbarrow, Mud Bucket, Mud Pan

For raising and lowering the MORTARMAN® 750, see the previous section on the set-up procedure.

3. Connect the water supply hose to the Chicago fitting provided. Practice operating the water control lever.....one direction discharges water into the drum.....the other direction sends water into the clean up hose.

****IMPORTANT NOTE* Before adding material to the mixing drum make certain no foreign objects are in the drum, and that the discharge gate is in the closed position.***

4. Now start the mixer, the mixing paddles should move smoothly as they pass around the drum, if their action is irregular and noisy, stop the mixer.....contact your local IMER Distributor or call IMER U.S.A. direct of (800) 275-5463.

****IMPORTANT NOTE* Machines equipped with combustion engines and key ignition must be started as follows: rotate the key clockwise, from position 0 to the next click (position 1) and keep turned to start the engine. If the machine does not start, attempt the start-up procedure again without insisting for more than 5 seconds at a time. Once the engine is started, leave the key in position 1, to enable the starter battery to recharge.***

5. With the mixer running at full power, add the cement and sand into drum dry...the MORTARMAN® has the ability to spin and mix a full load dry. This is a great feature , as it allows material to thoroughly blend and mix before water is added.

****IMPORTANT NOTE* The Mortarman® 750 is much different from a concrete mixer and cannot be used to mix material with aggregate (rocks). This is because the Mortarman® 750 has paddles which are driven through the material with huge amounts of torque.....should a paddle wedge a rock between itself and the drum, substantial damage will result.***

If the material being mixed is not bagged pre-mix or discharged from a silo system, then make certain there are no rocks in it.

Be especially cautious if sand is delivered by truck from a sand and gravel supply yard. Let them know when you order, that no rocks or pebbles of any type are allowed in your sand.

Some light aggregates, such as terrazzo pieces may be run in the mixer, however, contact IMER U.S.A. or your local dealer for the proper set-up techniques.

6. Fill the mixer to the top of the free spinning agitation trident paddle.....filling the mixer above this point will not provide sufficient mixing action for the loaded material.

REMEMBER: the MORTARMAN® 750 mixes incredibly fast.....there is no need to over load it.

7. Now that the material has mixed a few seconds dry, the water can be added until the desired consistency has been achieved.

8. Once the material is mixed to the consistency desired, position the appropriate container beneath the discharge chute area and then slide the discharge gate open.

9. If the mixer is stopped while material is still in the drum, do not allow the material to harden up. It is possible to re-start the mixer with up to 3/4 of a load in the drum. If the drum was at full capacity when the mixer stopped, discharge some material, then re-start the machine.

MAINTENANCE

The **MORTARMAN® 750** is designed to require very low maintenance, however, following the few basic maintenance procedures listed below will greatly reduce your machine's down time.

1. Clean the mixer thoroughly after each use and do not allow material to build up on any portion of the mixer.

REMEMBER - Always unplug the mixer, or disconnect the spark plug wire before performing any maintenance procedures.

2. Change the gearbox oil after the first 50 hours of operation, after that the oil should be changed every 250 hours. Changing the oil is a simple procedure, as the drain bolt and a sight window for the full level marking are located on the gearbox body. Use a premium SAE 90 gearbox oil when making the change.

3. Check the drive belt tightness when the machine arrives from our factory.....maintain the belts at this tension.....taunt, yet not extremely tight. **Caution**, if the belts are overly tightened, damage can result to the motor and the gearbox.

REMEMBER: drive belts experience the majority of stretch during the first 15 hours of operation, monitor the belts closely during break-in.

NOTE : NEVER touch or adjust the belts while the machine is operating

To tighten the belts the motor is moved forward, further away from the rear pulley. Make sure the two adjusting bolts are tightened in equal amounts, as the motor's drive pulley must stay in alignment with the gearbox pulley. Should the belts continually come off the pulley, check the following:

- condition of the belts, are they worn out, are they the proper specification
- alignment of the drive pulley and gearbox pulley, are they in line
- are the pulleys themselves in good condition?not bent or clogged with debris.

NOTE : it is not advisable to replace just one belt, they need to be replaced in sets. This is because a new belt needs a different degree of tightness than a used belt. It is always a good idea to have a spare set of belts in your truck.....replacement is straight forward and simple.....be smart and be prepared!

4. The paddle assembly hardware should be monitored and retightened the first 15 hours of operation. After the components have seated in, it is still a good idea to check the paddle hardware on a weekly basis, or whenever the machine is thoroughly cleaned.

Many contractors have found it very effective to have an additional set of paddles....when one set becomes ready for maintenance, remove the entire paddle spider and drop on the spare.

This procedure takes less than one hour and allows the used set of paddles to be set aside and maintained at your leisure.

As the paddle wiper rubber wears it is important to bring the distance between the wiper rubber, and the drum back to its original specification.....which is 5mm or 1/5".

DO NOT place the rubber flush against the drum..... this will cause the paddle to drag excessively and can lead to the paddle bending or breaking.

NOTE : Should the paddles ever begin to emit sharp scraping sounds, or the paddle spider system begin to vibrate heavily, stop the mixer. Disconnect all power and unload by hand if necessary. Do not restart the machine until the cause of the malfunction has been ascertained.

BATTERY:

- Keep the battery clean and dry.
- Use a moist anti-static cloth only to wipe the battery, otherwise there is a danger of explosion.
- Do not open the battery.
- Recharge in case of insufficient starting power.



5. The area underneath the discharge gate will need to be hosed off a few times a day. The discharge gate mechanism is equipped with a wiper which continually sweeps debris off the safety gate, however, a shot of water every now and then will ensure smooth discharge.

REMEMBERdo not remove the discharge safety grate under any circumstances.....keep this area clean and material discharge will be no problem...it is not worth lost fingers and hands to remove the safety grate!

6. Do not disconnect the safety interlock system on the mixer drum safety grate. Should it begin to malfunction see your IMER Distributor immediately, or call IMER U.S.A. direct at (800) 275-5463.

7. Regarding motor maintenance, please review the manufacturer's manual which is supplied with each machine.

IT IS IMPORTANT that the mixer power plant run properly, or the material mixing action may not be thorough enough. The motor is the heart of this machine.....take care of it!

TECHNICAL SPECIFICATION

MORTARMAN® 750 MORTAR MIXER

		1 - PHASE	GASOL MOTOR
DRUM CAPACITY	l/Cu.ft	750/27	750/27
BATCH OUTPUT	l/Cu.ft	480/17	480/17
DICHARGE GATE	mm/inc	200/7,7"	200/7,7"
DIMENSION OF DRAW POS.		MIN.1390(55")x1416(55,5")x2124(83") MAX.1730(68")x1580(62")x2279(89,5")	
WEIGHT	Kg/Pounds	720/1580	720/1580
WHEELS	mm/inc	d.550x80 22" x3"	d.550x80 22" x3"
MOTOR POWER	Kw/Hp	4/5,5	8/11
R.P.M.	g/1'	35	34
MIX.TIME	min.	3 ÷ 4	3 ÷ 4
DRUM DIAMETER	mm/inc	1300(50")	1300(50")

***Due to Imer U.S.A. 's commitment to
Reasearch and Development,
specifications are subject to change
without notice.***



WIRING DIAGRAM

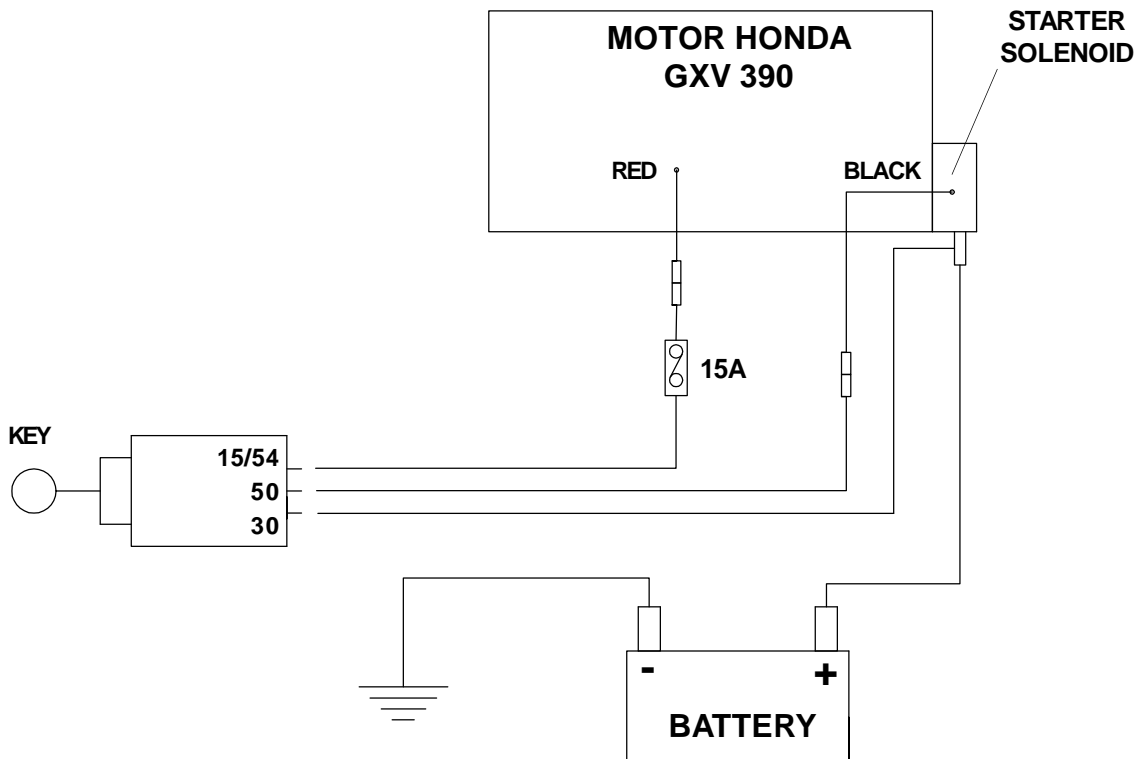
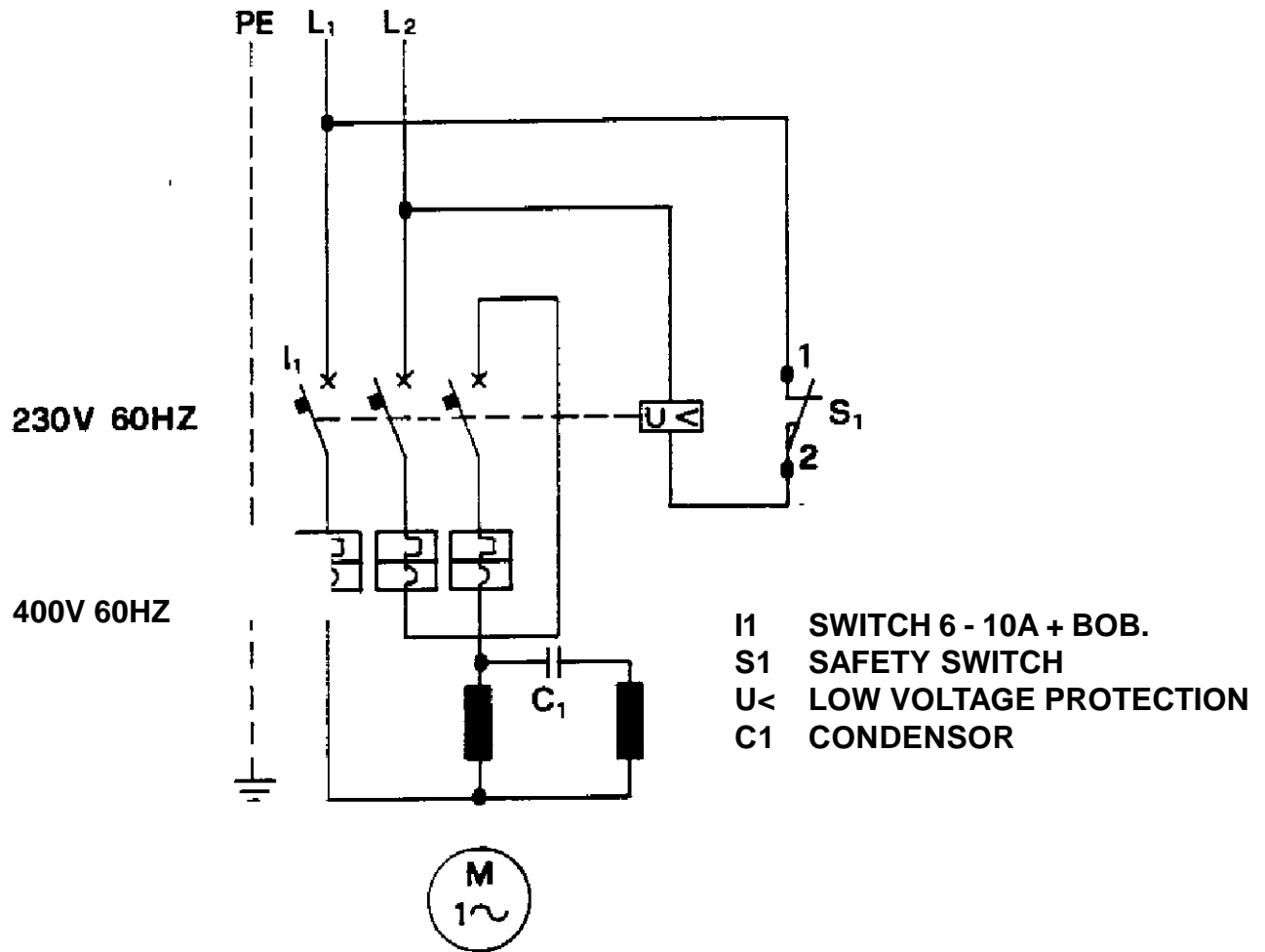



SPARE PARTS LIST
MORTARMAN® 750 MORTAR MIXER



TABLE 1 Mixer drum and paddle assembly

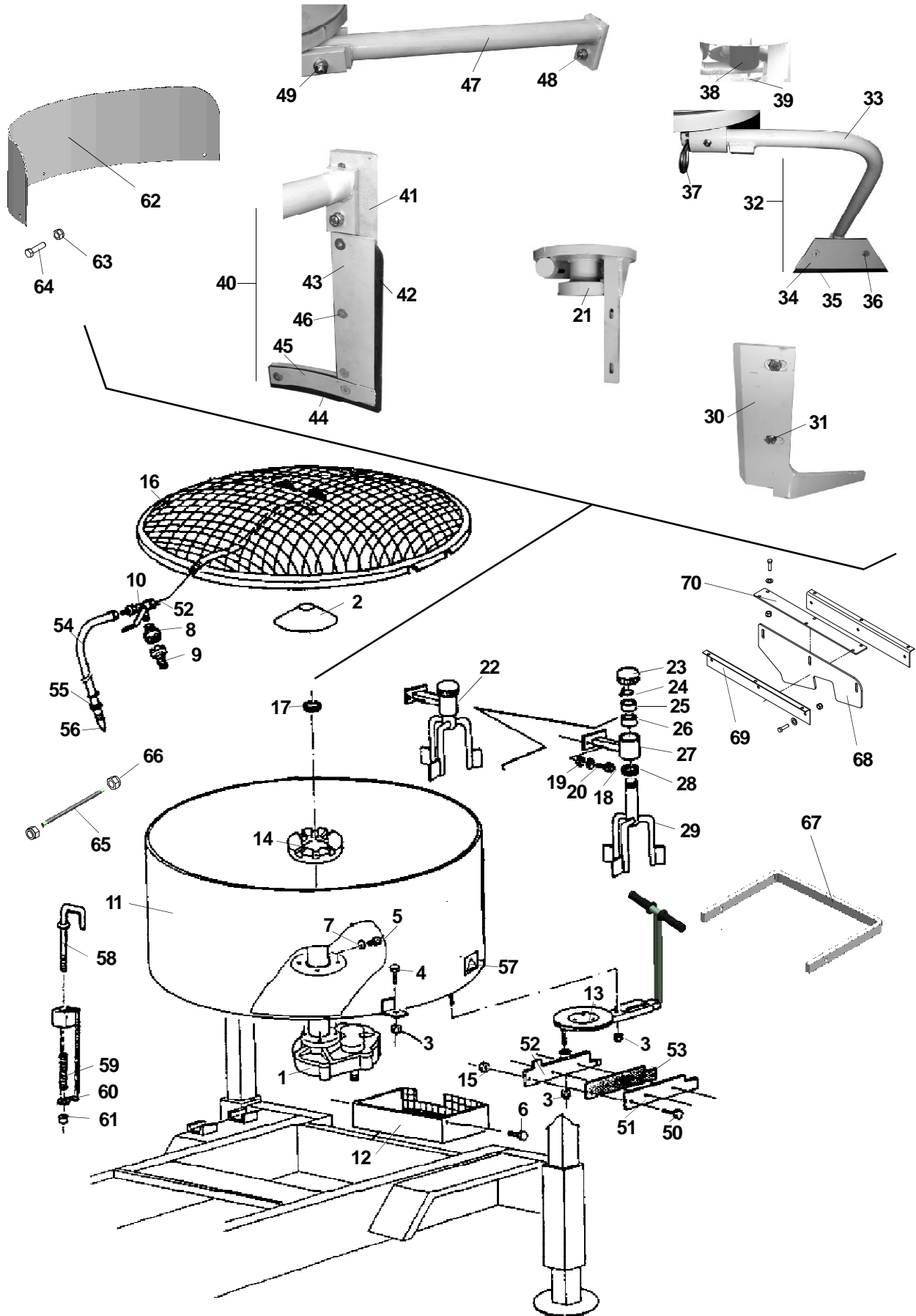



TABLE 1 Mixer drum and paddle assembly

Ref.	P.n.	Description	NOTES
1	3211258	REDUCTION GEAR	
2	3211270	MUSHROOM	
3	2223921	NUT	M12
4	2222035	BOLT	M12x25 Z
5	2222050	BOLT	M12x45 Z
6	3210871	BOLT	M16x 80
7	2224900	WASHER	DEV. Ø12
8	2226800	CONNECTOR FEMALE	
9	2226805	CONNECTOR MALE	
10	2218068	BALL VALVE	
11	3211293	DRUM	
12	3211565	DISCHARGE SAFETY GRATE	
13	2250748	DISCHARGE OPENING	
14	3211305	DRUM COLLAR	
15	2223924	LOCK-NUT	
16	3211638	DRUM SAFETY GRATE	
17	3211256	SEAL	
18	2222550	BOLT	
19	2224380	WASHER	
20	2224900	WASHER	
21	3211241	MIXER HEAD	
22	3211234	TRIDENT PADDLE	
23	2257710	CAP	
24	2227220	CIRCLIP	E/40
25	3205992	CIRCLIP	
26	2204505	BEARING	
27	3211235	SUPPORT ARM - TRIDENT	
28	3206003	SEAL	
29	3211238	TRIDENT ONLY	
30	3211255	INNER PADDLE	
31	2222050	BOLT	
-	2223921	NUT	
-	3211038	WASHER	
32	3211692	PADDLE COMPLETE	
33	3211676	FLOATING PADDLE	
34	3211678	FLOATING PLATE	
35	3211679	FLOATING RUBBER	
36	2223655	NUT	
-	2224340	WASHER	
-	2222559	BOLT	
37	3211257	PIN	
38	3211253	SHOCK-ABSORBER	
39	3206902	BOLT	
40	3211691	PADDLE COMPLETE	
41	3211672	OUTER PADDLE	
42	3211221	VERTICAL RUBBER OUTER PADDLE	
43	3211222	VERTICAL PLATE OUTER PADDLE	
44	3211675	ORIZONTAL RUBBER OUTER PADDLE	
45	3211674	ORIZONTAL PLATE OUTER PADDLE	
46	3211392	BOLT	
-	2224340	WASHER	
-	2223655	NUT	
47	3211250	SUPPORT OUTER PADDLE	
48	2222050	BOLT	
49	3206902	BOLT	
50	2222016	BOLT	
51	2253853	PLATE	
52	2253852	PLATE	
53	2247876	RUBBER PLATE	
54	2292356	WATER TUBE	
55	2225741	HOSE CLAMP	
56	2218069	NOZZLE	
57	2288205	ADHESIVE LABEL	
58	2201918	LEVER	
59	2231234	SPRING	
60	2224640	WASHER	
61	2223929	SELF LOCKING NUT	
62	3211559	DUST SHEET	
63	2223920	NUT	M10X25
64	2222056	BOLT	M10
65	3211641	ROTATION PIN FOR TANK OPENING	
66	3201033	NUT	M18
67	3211560	ROLLBAR	
68	3211634	GASKET	
69	3211637	RUBBER TIGHTENING PLATE	
70	3211636	SCRAPER SUPPORT PLATE	
-	2222146	BOLT	M10X30
-	2224340	WASHER	10X21
-	2223650	NUT	M10



TABLE 2 Dump gate			
Ref.	P.n.	Description	NOTES
0.1	3211633	DUMP GATE COMPLETE	
1	3211561	DRIVE LEVER	
2	1222147	BOLT	
3	1224809	WASHER	
4	2231301	SPRING	
5	2237795	ACTUATOR	
6	2209822	BUSHING	
7	2222600	SCREW	TSP 963-6x25
8	2225033	BASE PLATE	
9	2292581	SEAL	
10	2253863	BASE PLATE	
11	2223924	LOCK-NUT	M6
12	2223920	LOCK-NUT	M10
13	2254015	ACTUATOR FRAME	
14	2209821	BUSHING	
15	2223006	BOLT	

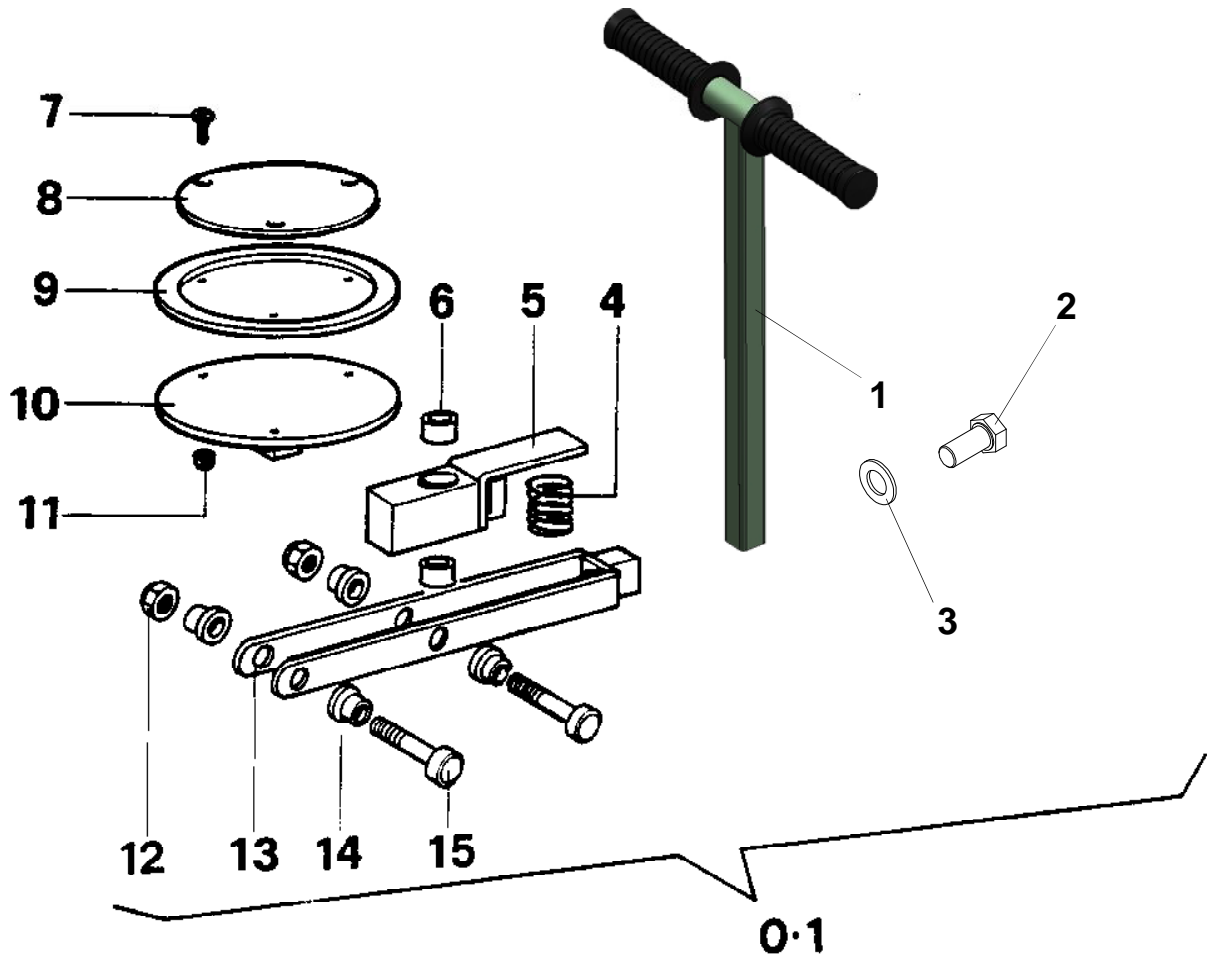



TABLE 3 Wheel and suspension assembly

Ref.	P.n.	Description	NOTES
1	3211393	AXLE	
2	3210607	BOLT	
3	3296035	WHEEL COMPLETE	
4	2222142	BOLT	5737 M12X100 Z
5	3207392	NUT	METALBLOC M12
6	2224380	WASHER	6593 D.12X25 Z

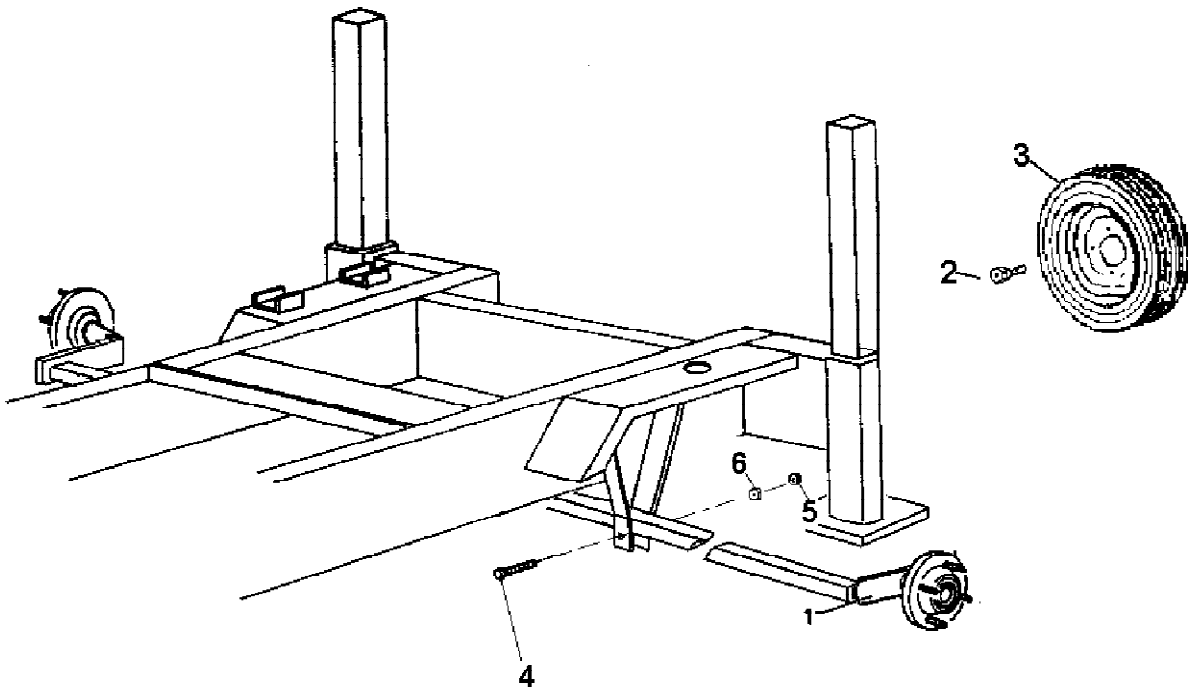



TABLE 4 Frame

Ref.	P.n.	Description	NOTES
1	2222566	BOLT	5931 M12x80
2	2222016	BOLT	6950 M6x20
3	2216277	GASKET	
4	2225745	CAP	Ø 32 - 52
5	2222421	NUT	M12
6	2226700	SLIP PIN	
7	3211268	THREADED INSERT	
8	2234861	TOW CHAIN	
9	3211665	MAIN FRAME	
10	3211330	BASE PLATE	
11	2255211	TOW BAR	
12	3211625	TELESCOPIC FOOT	
13	3211695	JACK	
14	2256550	ANCHOR PIN	
15	2256600	ANCHOR PIN	
16	2257706	CAP	
17	3211644	CANOPY	
18	2292298	QUICK CLIP	
19	2292370	RUBBER HOSE	
20	2223570	NUT	5588 M8
21	3211242	I.D. PLATE	400V-60
21.1	3211333		HONDA
23	2288825	WASHER	
24	2222513	BOLT	
25	2235460	COTTER PIN	M. 1"
26	2222056	BOLT	M10X25
27	3211649	PROTECTION	
28	2224340	WASHER	10X21
29	2223920	NUT	M10
30	3211681	LH SLIDING LEG	
31	3211680	RH SLIDING LEGX	
32	3211557	FORKLIFT	
33	2222082	BOLT	M10 X 60
34	2223920	NUT	M10

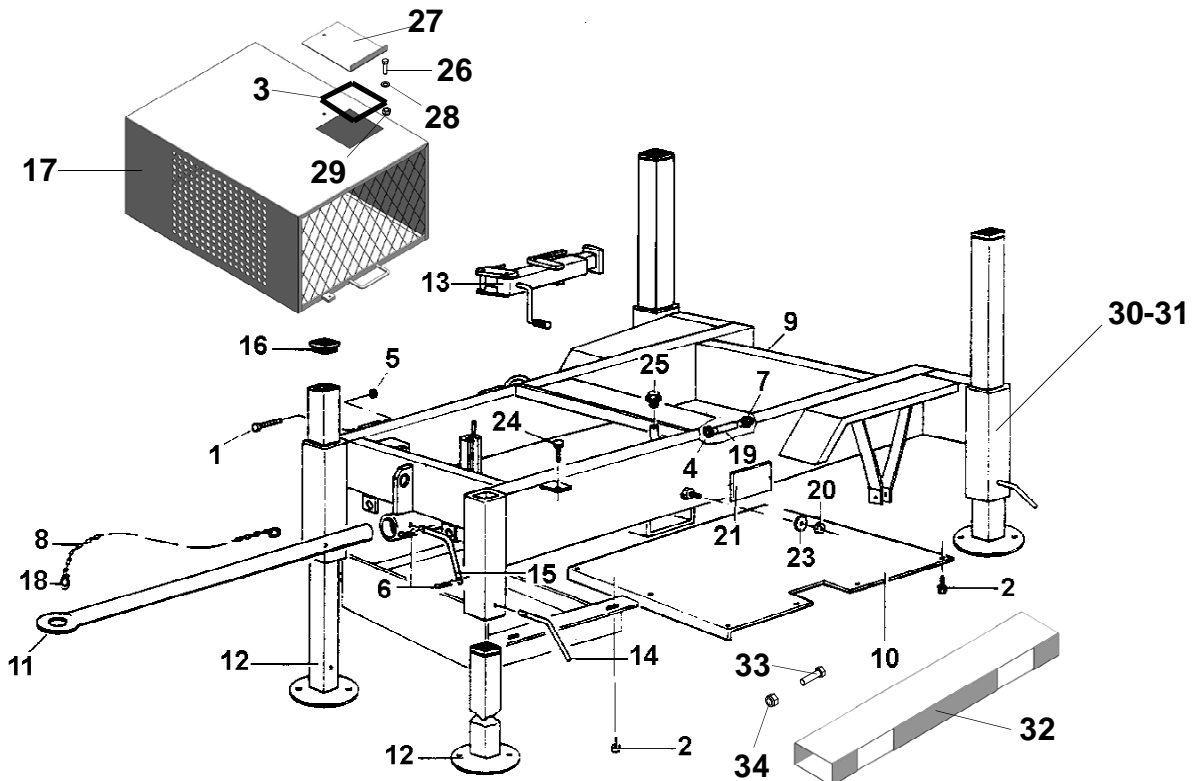



TABLE 5 Gearbox

Ref.	P.n.	Description	NOTES
1	2201163	DRIVE SHAFT	
2	2208498	WASHER	
3	2215093	GEAR BOX	
4	2258008	DRIVE SHAFT HOUSING	
5	2293985	CAP	
6	1224809	WASHERA16	
7	1222147	BOLT	M14X40
8	2204321	BEARING	4206
10	2204627	BEARING	222207
11	2204569	BEARING	6211
12	3223343	CROWN GEAR Z75	
13	3211260	PINION GEAR Z13	
14	3223342	PINION GEAR Z16	
15	3211262	CROWN GEAR Z58	
16	2204569	BEARING	
18	2229641	KEY	14X14X44
19	2229348	KEY	8X7X45
20	2229540	KEY	12X8X22
21	2222539	BOLT	M6X16
22	2222006	BOLT	M8X30

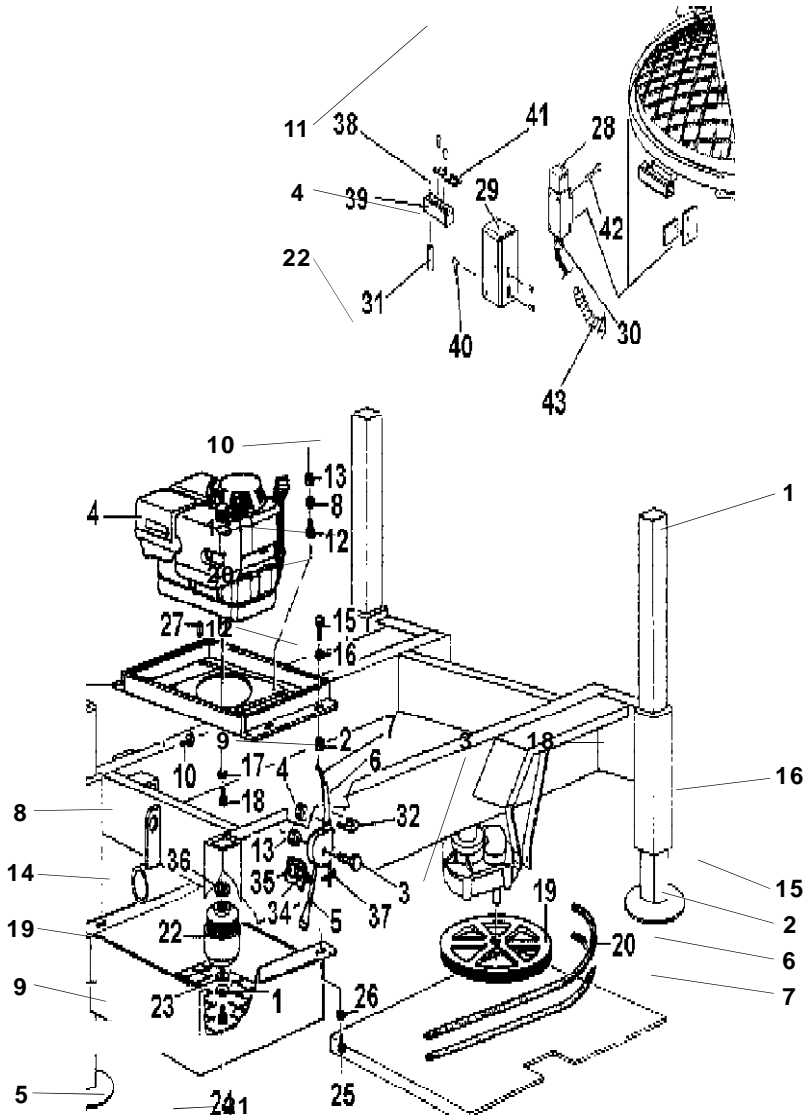



TABLE 7 ASSEMBLY OF MOTOR 400V 60HZ (1194625)

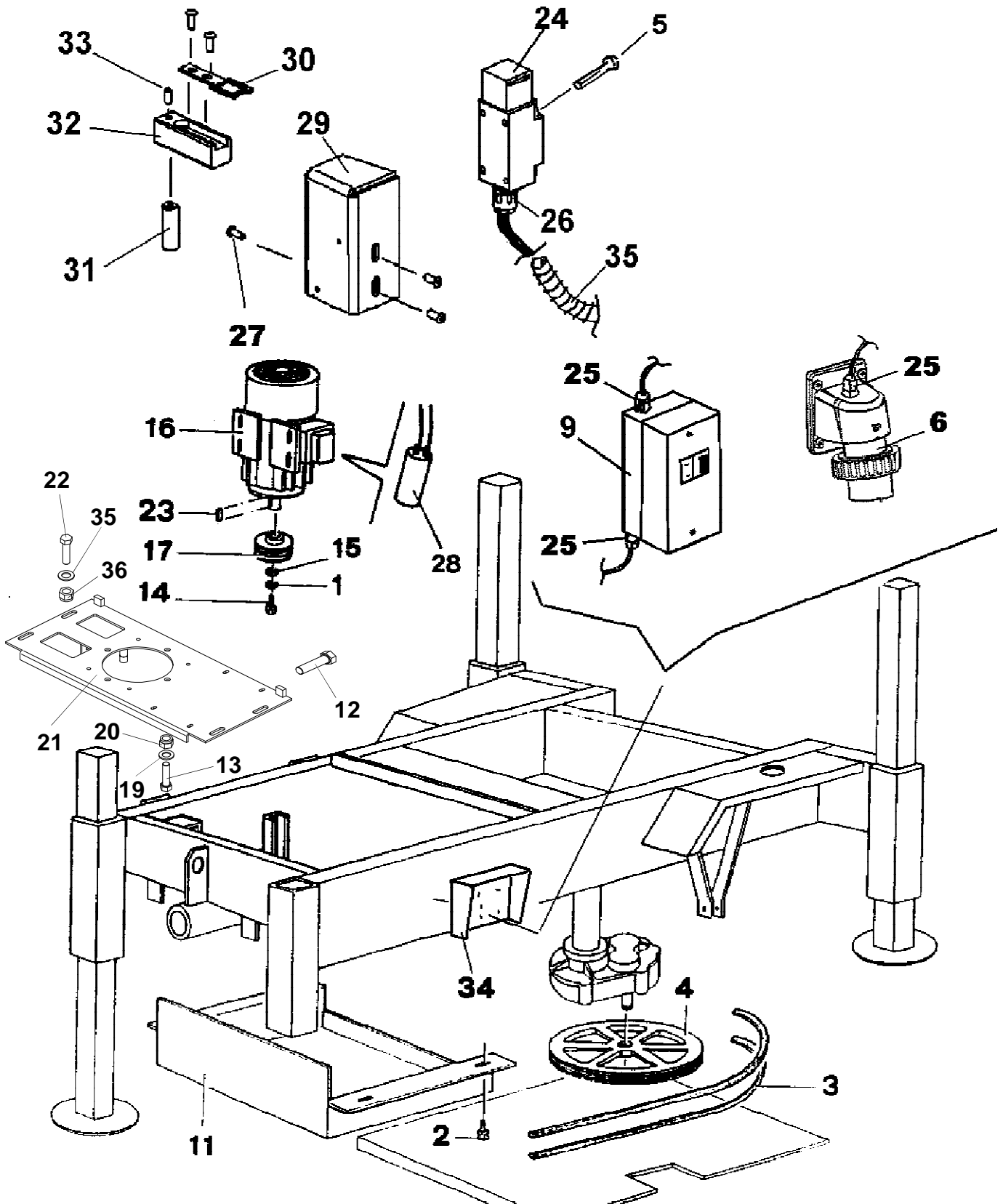



TABLE6 ASSEMBLY OF MOTOR 400V 60Hz

Ref.	P.n.	Description	NOTES
1	2224910	WASHER	
2	2222425	BOLT	AUTOFORTE 4,2X13
3	3211097	BELT	
4	3211750	PULLEY	
5	3209690	BOLT	
6	2278707	PLUG	
7	2222580	SREW	DIN 4A M4X20
8	2223500	NUT	5588 M4
9		SWTCH	
10	3211086	ADHESIVE LABEL	
11	3211642	PROTECTION	
12	3211076	BOLT	M10X80
13	2222007	BOLT	M12X35
14	2222735	SCREW	
15	2224206	WASHER	
16		ELECTRIC MOTOR	400V-60HZ KW:3
17	3211751	PULLEY	
18	2223600	NUT	
19	3206904	WASHER	6592 12X36X4
20	2223921	NUT	M12
21	3211632	MOTOR MOUNTING PLATE	
22	2222036	BOLT	M12X35
23	2229340	KEY	8X7X50
24	3211072	LIMIT SWITCH	
25	3201442	CABLE CLAMP	PG16
26	3201216	CABLE CLAMP	PG13.5
27	3211066	BOLT	7380 M6X16
28		CONDENSER	
29	3211068	SUPPORT	
30	3211065	SPANNER	
31	3211067	PIN	
32	3211064	SUPPORT	
33	3211075	BOLT	7380 M6X40
34	3211391	SHEATH	
35	3206904	WASHER	9593 12X36
36	2223921	NUT	M12



TABLE 8 Drive train Honda (1194620)

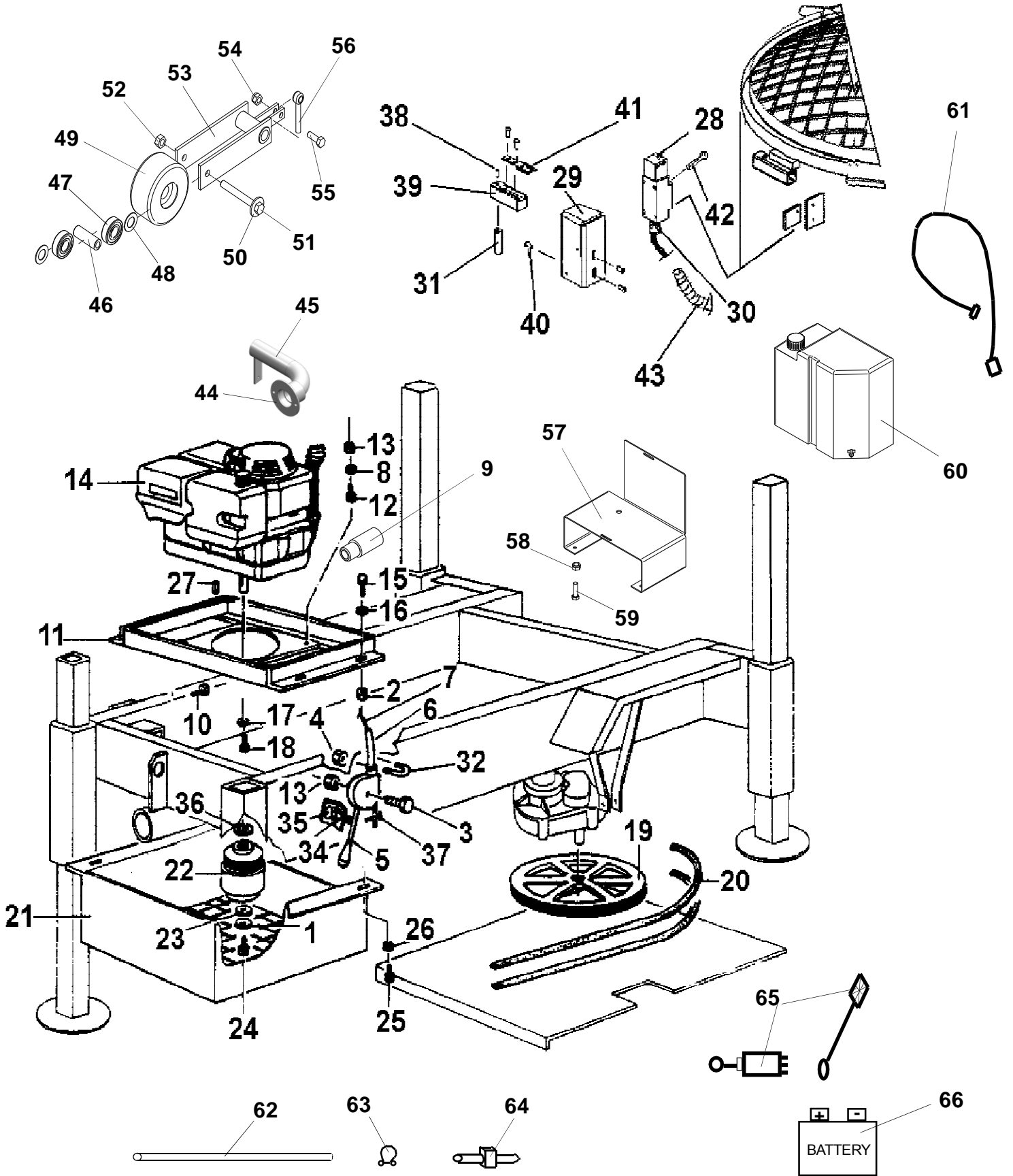



TABLE 8 Drive train Honda (1194620)

Ref.	P.n.	Description	NOTES
01	2224910	WASHER	Dev.C72 Ø10Z
02	2223921	NUT	M12
03	2222587	SCREW	5933 M8x20
04	2223500	NUT	5588 M4Z
05	2284805	THROTTLE CONTROL	
06	2284398	THROTTLE CABLE SHEATH	
07	2212120	INNER CABLE	
08	2224140	WASHER	6593 Ø8 x18
09	3211706	OIL DRAIN TUBE	
10	2222054	BOLT	TE 8.8 5739 12x80Z
11	3211632	MOTOR MOUNTINGPLATE	
12	2222088	BOLT	5737 M8x40
13	2223923	LOCK-NUT	M8
14		MOTOR	GXV 390
15	2222036	BOLT	M12X35
16	3206904	WASHER	6593 Ø 12X36
17	2224940	WASHER	DEV.C 72 Ø8 Z
18	2221994	BOLT	TE 8.8 5/16"x25 Z
19	3211343	PULLEY	
20	3211710	BELT	Ax88
21	3211632	CLUTCH COVER GUARD	
22	2289357	CLUTCH COMPLETE	
23	2224340	WASHER	6592 Ø10x20 Z
24	2221991	BOLT	TE8.8UNF3/8"x60Z
25	2222776	BOLT	TE/4S 5739 6x16 Z
26	2223924	LOCK-NUT	AUTOBL.M6
27	2229845	KEY	4X 6.5 UNI 6606
28	3211072	SAFETY SWITCH	FD515
29	3211068	SUPPORT	
30	2278090	CORD GRIP	PG13.5
31	3211067	PIN	
32	2292298	SPRING CATCH	
33	2224951	WASHER	Dev.Ø5
34	2222006	STOP BOLT	5739 M8x30
35	2223570	NUT	5588 M8
36	2237748	SPACER	
37	2225796	CLAMP	
38	3211075	BOLT	7380 M6x40
39	3211064	SUPPORT	
40	3211066	BOLT	7380 M6x16
41	3211065	SPANNER	
42	3209690	BOLT	
43	3211391	SHEATH	
44	3211663	EXHAUST MANIFOLD	
45	3211707	EXHAUST TUBE	
46	3211659	BELT TENSIONER WHEEL BEARING BUSH	
47	2204560	BEARING	6204 2RS
48	3211660	BELT TENSIONER WHEEL BEARING SPACER	
49	3211658	BELT TENSIONER WHEEL	
50	2224380	WASHER	
51	3201498	BOLT	
52	2223921	NUT	
53	3211657	BELT TENSIONER UNIT	
54	2223920	NUT	
55	3211392	BOLT	
56	3210353	TIE-ROD	
57	3211643	TANK SUPPORT PLATE	
58	2223920	NUT	
59	2222059	BOLT	
60	3211697	TANK	30LT
61	2289425	THONG	L2500-AD2
62	3211699	PETROL HOSE	95001-4500860M
63	3211700	CLIPS	95002 0280
64	3211698	PETROL FILTER	16910GB2005
65	3211709	COMBUSTION ENGINE ELECTRIC IGNITION KIT	
66	2276001	BATTERY	54579 12V-45AH



EQUIPMENT WARRANTY

IMER U.S.A. INC.

3654 Enterprise Avenue
Hayward, 94545
California

Toll Free: (800) 275-5463
Office: (510) 670-7970
Fax: (510) 783-4255

We warrant to the original purchaser that the IMER equipment described herein (the "equipment") shall be free from defects in material and workmanship under normal use and service for which it was intended for period of one (1) year from the date of purchase by the original purchaser.

Our obligation under this warranty is expressly limited to replacing or repairing, free of charge, F. O.B. our designated service facility, such part of the equipment as our inspection shall disclose to be defective. Parts such as engines, motors, pumps, valves, electric motors, etc. furnished by us, but not manufactured by us, will carry only the warranty of the manufacturer. Transportation charges or duties shall be borne by purchaser. This shall be the limit of our liability with respect to the quality of the equipment.

This warranty shall not apply to any equipment, or parts thereof, which has been damaged by reason of accident, negligence, unreasonable use, faulty repairs, or which has not been maintained and operated in accordance with our printed instructions for the equipment. Further, this warranty is void if the equipment, or any of its components, is altered or modified in any way.

THIS WARRANTY IS EXPRESSLY IN LIEU OF ALL OTHER WARRANTIES, EXPRESSED OR IMPLIED, INCLUDING ANY IMPLIED WARRANTY OF MERCHANTABILITY OR FITNESS FOR A PARTICULAR PURPOSE.

We make no other warranty, representation or guarantee, nor is anyone authorized to make one on our behalf. We shall not be liable for consequential damage of any kind, including loss or damage resulting, directly or indirectly, from the use or loss of use of the machine. Without limiting the generality of the foregoing, this exclusion from liability embraces the purchaser's expenses for downtime, damages for which the purchaser may be liable to other person, damages to property, and injury or death of any persons.

This warranty shall not be deemed to cover maintenance parts, including but not limited to blades, belts, hoses, hydraulic oil, or filters, for which we shall have no responsibility or liability whatsoever.



When you mail the Guarantee-Registration Card below, your



IMER U.S.A. INC.

Guarantee is void unless Guarantee-Registration Card is returned to us within 10 days o delivery. (The terms off our Guarantee are given on the back off this card.)

IMER U.S.A. INC.

3654 Enterprise Avenue
Hayward, 94545 - California
Toll Free: (800) 275-5463
Office: (510) 670-7970
Fax: (510) 783-4255

"TOOLS AND SERVICES FOR THE 21st CENTURY"

FILL OUT CARD BELOW - TEAR OFF AND MAIL

Guarantee-Registration Card

(Return this card within 10 days after delivery of your new machine)

My Name _____

My Address _____

City, State _____

Zip, Code _____

Type of Machine _____

Model _____

Serial N. _____

Purchased from _____

City, State _____

Zip Code _____

Date Delivered _____

Condition of crate package at time of delivery _____

Information asked below is required for guarantee but will help us provide you better service.

Do you have other IMER USA Inc products?

Yes No

What type of material will be cut this Machine?

Do you wish FACTORY RECOMMENDATIONS for this type of material? _____

Yes No

Thank you for the opportunity to be of service.

IMER U.S.A. INC.

3654 Enterprise Avenue
Hayward, 94545 - California
Toll Free: (800) 275-5463
Office: (510) 670-7970
Fax: (510) 783-4255

As soon as your Guarantee-Registration Card is received, the Serial Number of your IMER USA Inc. Machine will be registered in our log and our guarantee will be in effect.

Your IMER USA Inc. Machine is guaranteed against mechanical defects for one year from date of purchase. Special parts such as engines, motors, power transmissions, etc., not of IMER USA Inc. manufacture are guaranteed as stated in the operating instructions accompanying the machine.

"This guarantee does not apply if the above equipment 1) has been repaired without factory direction or 2) if it has been damaged by improper assembling or 3) from other cause for which the user is responsible, or 4) used for an improper purpose. Thoroughly inspect the above equipment periodically and give prompt notice of any defects if you desire this guarantee to remain effective".

IMER U.S.A. INC.

3654 Enterprise Avenue
Hayward, 94545 - California
Toll Free: (800) 275-5463
Office: (510) 670-7970
Fax: (510) 783-4255
