

ATRIUM LIFT

Series IM R 19

STANDARD EQUIPMENT

- Automatic outrigger leveling system
- Emergency hand pump
- Cylinder holding valve
- Hour meter
- Load and tip detection sensor
- Load cell
- Hydraulic jib
- Rubber tracks
- Hydraulically adjustable track width
- 120V - 16 A electric motor for indoor use
- Air / Water outlet in the platform basket
- Removable wired control box
- Three travel speeds
- Wired control
- Remote battery charger
- Removable basket with 1 pin detach
- Overload sensor
- AC power to platform
- 120V battery charger
- Proportional controls with diagnostics
- GX390 Honda Engine

OPTIONAL EQUIPMENT

- 12 V emergency pump
- Non-marking rubber tracks
- Oversized 14" outrigger pads
- Wireless radio remote control box
- Working light in the platform basket

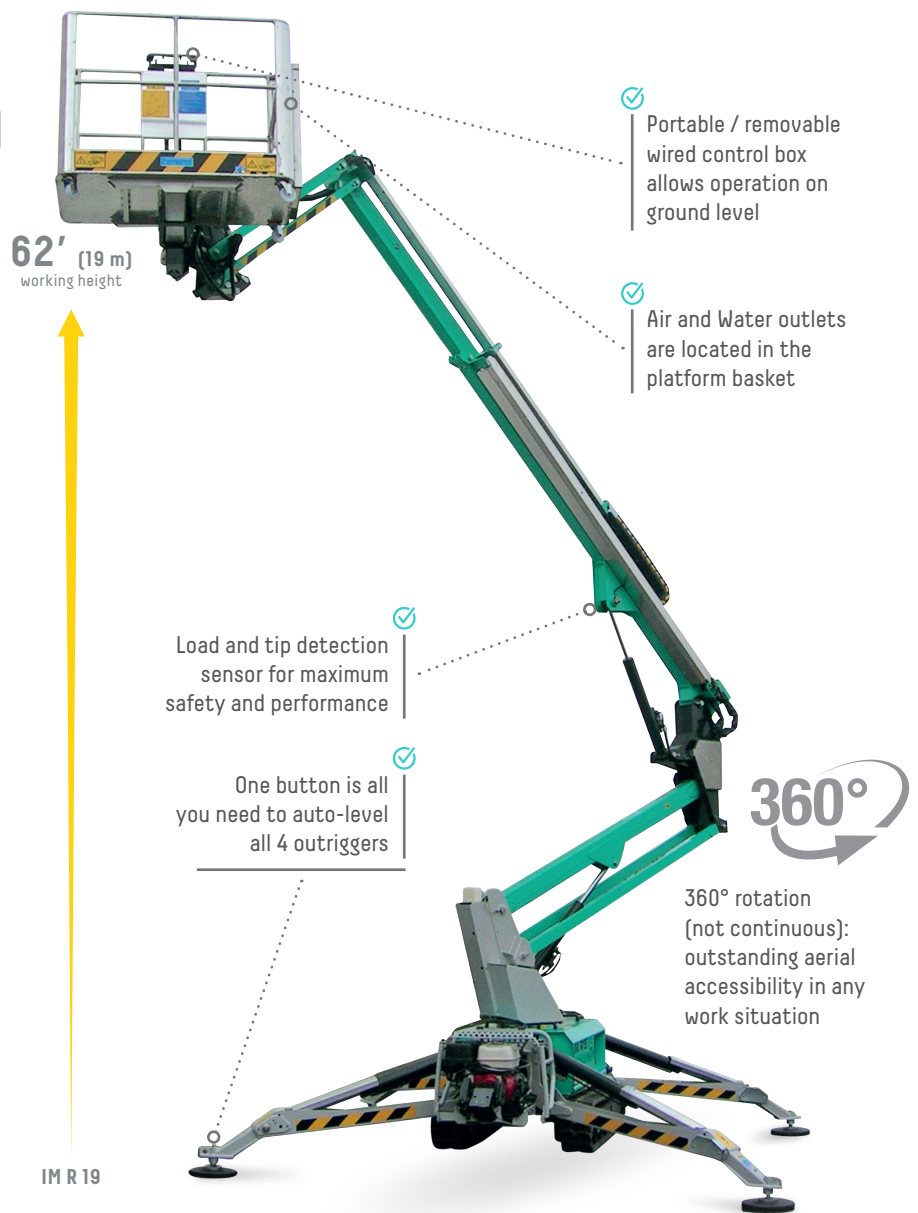

OUTDOOR AND INDOOR USE

	IM R 19			
		Metric		US
Working height	m	19	ft	62
Platform height	m	17	ft	56
Side outreach	m / kg	9.75 / 80 - 8.5 / 120 - 7 / 227	ft / lb	32' / 176 - 28' / 310 - 23' / 510
Rotation (not continuous)	deg	355°	deg	355°
Basket dimensions	mm	1448 x 711 x 1092	in	57" x 28" x 43"
Basket rotation	deg	124°	deg	124°
Transport length (without basket)	mm	5308 / 4622	ft	17' 5" / 15' 2"
Transport width (without basket)	mm	Min 787 / Max 1066	ft	Min 2' 7" / Max 3' 6"
Height in stowed position (w/ stabilizers in position)	mm	Min 1981 / Max 2108	ft	Min 6' 6" / Max 6' 11"
Overall outrigger footprint	mm	2896 x 2946	ft	9' 6" x 9' 8"
Stabilizer Load	daN	1750	ft-lb	3930
Driving speed	km / h	0 - 2	mph	0 - 1.24
Gradeability	%	32	%	32
Electric pump	V / kW	120 / 1.125	V / HP	120 / 1.5
Max. hydraulic pressure	bar	220	psi	3190
Battery	V/Ah	12	V/Ah	12
Battery charger	V/A	12 / 12	V/A	12 / 12
Gas motor		Honda GX390 - 11 HP 3600 rpm		Honda GX390 - 11 HP 3600 rpm
Machine Weight	kg	2435	lb	5370

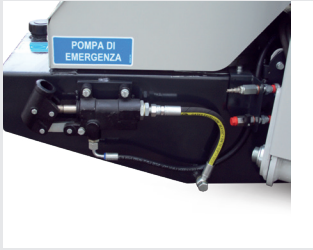

Emergency hand pump with ease of access and operation.

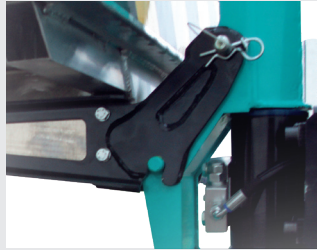

Basket mounting system designed for easiness of assembly.

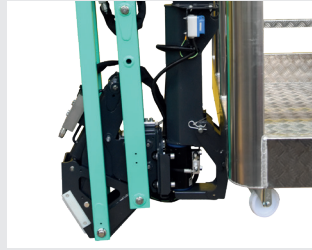

Compactness of the jib assembly hosting both the load cell and basket rotation system.

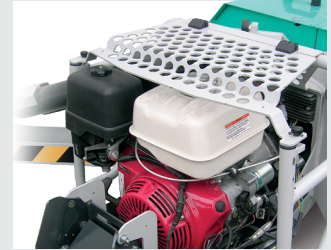

Rugged engine guard for improved protection.



The compact dimensions allow you to take the IM R19 almost anywhere!

