

# MK-1600 OWNER'S MANUAL & OPERATING INSTRUCTIONS

## Gas Powered Concrete Saw



Revision 202	03.2013
Manual Part# 157841	

**Caution:** Read all safety and operating instructions before using this equipment. This owner's manual **MUST** accompany the equipment at all times.

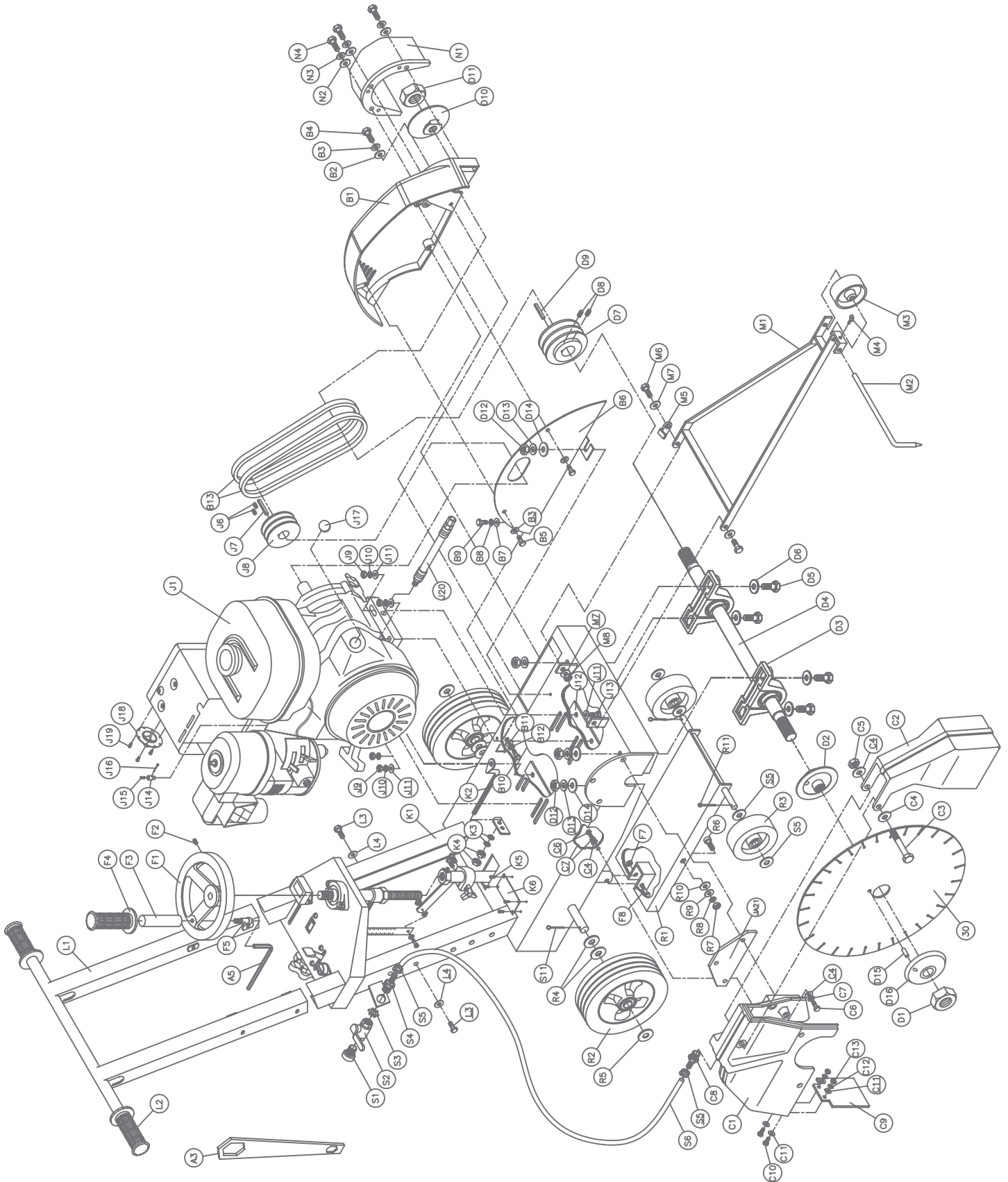

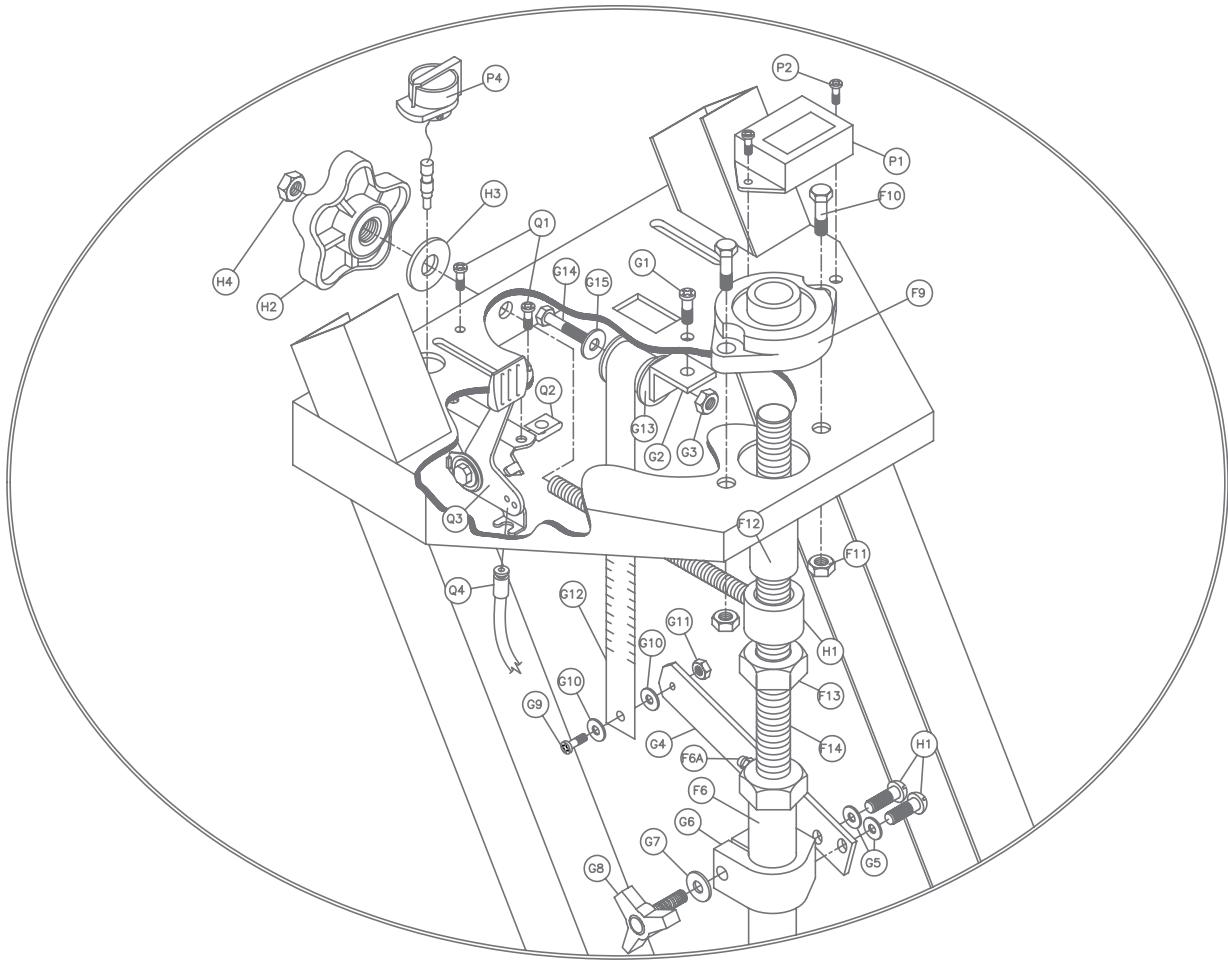

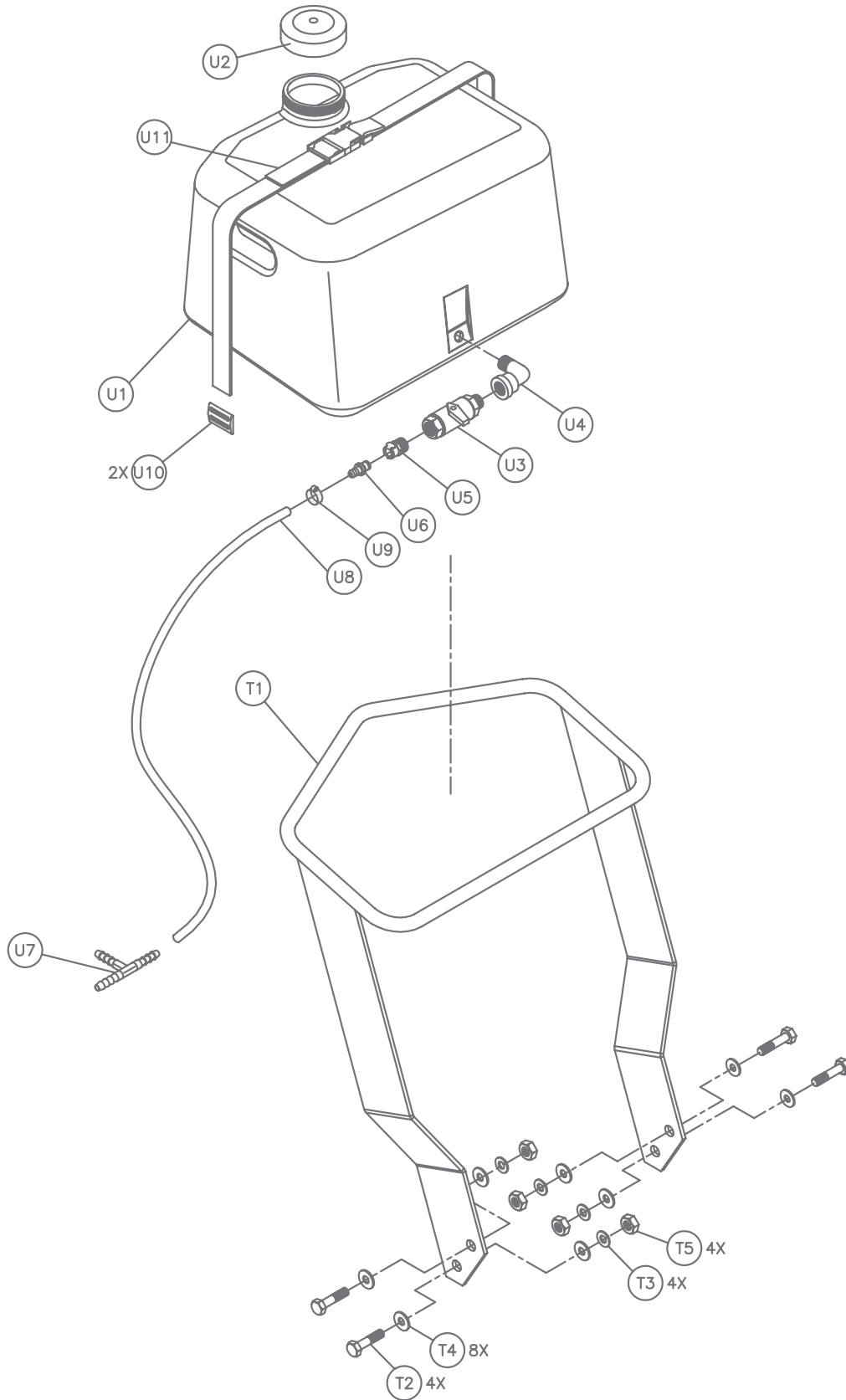

Item	Description	Qty	Part#
A1	Owner's Manual, MK-1600	1	157841
A2	Warranty Card	1	155859
A3	Wrench	1	137976
A4	Key, 1/4 Hex	1	156235
B1	Belt Guard	1	157704
B2	Washer, 5/16 SAE Flat	3	151754
B3	Washer, 5/16 Split Lock	3	151747
B4	Screw, 5/16-18 X 1 Hex Head Cap	1	151743
B5	Screw, 5/16-18 X 3/4 Hex Head Cap	2	151369
B6	Back Plate, Belt Guard	1	157705-DD
B7	Washer, 1/4 SAE Flat	1	151915
B8	Washer, 1/4 split lock	1	152591
B9	Screw, 1/4-20 X 1/2 Hex Head Cap	1	152608
B10	Screw, 3/8-16 X 3/4 Hex Head Cap	1	153527
B11	Washer, 3/8 SAE Flat	1	150923
B12	Washer, 3/8 Split Lock	1	150925
B13	Belt, 3VX280	3	160615
B14	Label, Caution, Belt Tension, 1.5 X 3.0	1	155583
B15	Label, Caution, Guards in Place, 1.5X3.0	1	155587
B16	Label, Caution, Sparkplug	1	155579
C1	18" Rear Blade Guard	1	159544
C2	18" Front Blade Guard	1	159645
C3	Screw, 3/8-16 X 4 Hex Head Cap	1	153531
C4	Washer, 3/8 SAE Flat	6	150923
C5	Nut, 3/8 - 16 X Nylock Hex	1	152505
C6	Nut, 3/8 - 16 X 1 Hex Head Cap	4	152507
C7	Washer, 3/8 split Lock	4	150925
C8	Fitting, Brass, 1/8 MNPT X Barb	1	152501
C9	Flap, Rubber Splash	1	150846
C10	Screw, 1/4 - 20 X 1/2 Hex Head Cap	2	152608
C11	Washer, 1/4 SAE Flat	4	151915
C12	Washer, 1/4 Split Lock	2	151893
C13	Nut, 1/4 - 20 Hex	2	151893
C14	Label, Caution, Lift Guard, 1.5 x 3.0	1	155586
C15	Label, Blade Failure Warning	1	155588
D1	Nut, Blade Shaft, 3/4 - 16 Left Hand	1	155069
D2	Flange, Inner, Left Hand	1	155068
D3	Bearing, 1" Pillow Block	2	155072
D4	Shaft, Blade, Premium	1	157842
D5	Screw, 7/16 - 14 X 1-1/2 Hex Head Cap	4	155155
D6	Washer, 1/2 SAE Flat	4	150924
D7	Pulley, 2 Groove, 3-1/4 x 1 Balde Shaft	1	160613
D8	Screw, 5/16-18 X 1/4 Socket Head Set	2	152607
D9	Key, Square, 1/4 X 1/4 x 1 3/4	1	150796
D10	Flange, Inner, Right Hand	1	157843
D11	Nut, Blade Shaft, 3/4 - 16 Right Hand	1	157844
D12	Nut, 7/16 - 14 Hex	4	150922
D13	Washer, 7/16 Split Lock	4	151051
D14	Washer, 7/16 SAE Flat	2	151050
D15A	Pin, 3/8 X 1 Type "A" Groove	1	152207
D15B	Flange, Outer	1	150732
F1	Depth Control Wheel	1	155156
F2	Screw, 3/8 - 16 X 1/2 Socket Head Set	1	153710
F3	Handle, Depth Control Wheel	1	156236
F4	Handgrip	1	150842
F5	Screw, 1/2 X 3/4 Socket Head Shoulder w/ 3/8-16 X 5/8 Thread	1	156177
F6	Tube, Depth Control	1	155049

Item	Description	Qty	Part#
F7	Nut, 3/8-16 Nylock Hex	1	152505
F8	Screw, 3/8-16 X 2 Hex Head Cap	1	153485
F9	Bearing, Flange, w/ zerk fitting	1	155151
F10	Screw, 3/8-16 X 1 1/4 Hex Head Cap	2	150774
F11	Nut, 3/8-16 Nylock Hex	2	152505
F12	Spacer, Depth Control	1	155161
F13	Nut, 3/4-10 Hex	1	155063
F14	Screw, Depth Control	1	155062
G1	Screw, 1/4 - 20 X 1/2 Pan Head Phillips Cap	1	152517
G2	Bracket, Depth Indicator	1	156608
G3	Nut, 1/4 - 20 Hex	1	151893
G4	Arm, Depth Indicator	1	156604
G5	Washer, 1/4 Split Lock	2	152591
G6	Clamp, Depth Indicator	1	156604
G7	Washer, 5/16 SAE Flat	1	151754
G8	Knob, Davies	1	151681
G9	Screw, 8 - 32 X 1/2 Pan Head Phillips Cap	1	152517
G10	Washer, #8 SAE Flat	2	155454
G11	Nut, 8 - 32 Hex	1	152549
G12	Spring, Depth Indicator	1	156605
G13	Spool, 1.0 Depth Indicator	1	157845
G14	Screw, 1/4 - 20 X 1 - 1/2 Hex Head Cap	1	152517
G15	Washer, 1/4 SAE Flat	1	151915
H1	Lock, 8 - 7/8 Depth Control	1	157846
H2	Knob, Depth Lock	1	155845
H3	Thrust Washer	1	155845
H4	Nut, 3/8 - 16 Nylock Hex	1	152505
J1	Engine, Honda GX390 13hp w/ Cyclone Air Filter	1	155365
JA1	Engine, Kohler command Pro CS 12 hp (not shown)	1	157831
JB1	Engine, Honda 8 Hp w/Cyclone Air Filter	1	155133
J2	Label, Caution, Hot Surface, 1.5 x 3.0	1	155578
J3	Label, Warning, Refueling, 1.5 X 3.0	1	155580
J4	Label, Danger, California, 1.5 X 3.0	1	155581
J5	Label, Danger, Lethal Exhaust, 1.5 X 3.0	1	155582
J6	Screw, 5/16-18 X 1/4 Socket Head Set	2	152607
J7	Key, Square, 1/4 X 1/4 x 1 3/4	1	150796
J8	Pulley, 2 Groove, 3/14 X 1 Engine Pully	1	160614
J9	Nut, 3/8-16 Hex	4	101188
J10	Washer, 3/8 Split Lock	4	150925
J11	Washer, 3/8 SAE Flat	7	150923
J12	Plate, Engine Bolt	2	157847
J13	Screw, 3/8-16 X 2 Hex Head Cap	4	153485
J14	Pin, Throttle Control	1	151284
J15	Screw, 8-32 X 3/8 Pan Head Cap	1	156614
J16	Pin, Cotter, 1/16 X 3/4	1	152518
J17	Plug, Plastic, 3/4 Round	1	156615
J18	Deflector, Honda 11/13HP	1	155375
J19	Screw, 6-32 X 1/2 Pan Head Phillips Self-tapping Cap	3	153466
J20	Oil Drain, Sub-assembly Adapter, M12-1.5 x 3/8 Push	1	157577-02
K1	Frame	1	157836-DD
K2	Arm, Tension	1	157848
K3	Washer, 5/16 SAE Flat	2	151754
K4	Nut, 5/16-18 Hex	2	101196
K5	Label, Private Label Serial Number	1	157458
K6	Label, Console	1	159950
K7	Label, Depth Lock, 1.04 X 3.25	1	155577
K8	Label, Operating Instructions, 3.5 X 6.0	1	155584
K9	Label, Caution, Hands and Feet, 2.0 X 4.0	1	155585

Item	Description	Qty	Part#
L1	Handlebar	1	159903
L2	Handgrip, Neoprene	2	157855
L3	Handlebar Plugs	2	156615
L4	Screw, 3/8-16 X 2 Hex Head Cap	2	153485
L5	Washer, 3/8 SAE Flat	2	150923
M1	Arm, Pointer	1	156544
M2	Pointer	1	155057
M3	Wheel, Pointer	1	155066
M4	Screw, 1/4-20 X 3/4 Thumb	2	150991
M5	Clip, Stop	1	157837
M6	Screw, 3/8-16 X 1 1/2 Hex Head Cap	2	153528
M7	Washer, 3/8 SAE Flat	4	150923
M8	Nut, 3/8-16 Nylock Hex	2	152505
N1	Guard, Shaft	1	156307
N2	Washer, 3/8 SAE Flat	3	150923
N3	Washer, 3/8 Split Lock	3	150925
N4	Screw, 3/8-16 X 1 Hex Head Cap	3	152507
N5	Label, Caution, Guards in Place, 1.5X3.0	1	155587
P1	Tachometer/ Hour meter	1	153877
P2	Screw, 8 - 32 X 1/12 Pan Head Phillips Self-Tapping Cap	2	156632
P3	Wire Harness, Premium, Honda (not Shown)	1	156633
P4	Switch, Engine On/Off	1	157851
Q1	Screw, 10-24 X 1/2 Pan Head Phillips Cap	2	151744
Q2	Nut, 10-24 Clip	2	155407
Q3	Assembly, Throttle Head	1	155406
Q4	Cable, Throttle, Honda	1	154158
R1	Truck	1	155048
R2	Wheel, Rear, 8 X 2 1/4	2	155986
R3	Wheel, Front, 4 X 1 1/2	2	150830
R4	Washer, 3/4 SAE Flat	4	153523
R5	Washer, 3/4 Shim	6	153699
R6	Screw, 1/2 X 1/2 Socket Head Shoulder, w/ 3/8-16 X 5/8 Thread	2	151753
R7	Nut, 3/8-16 Hex	2	101188
R8	Washer, 3/8 Split Lock	2	150925
R9	Washer, 3/8 SAE Flat	3	150923
R10	Washer, 1/2 SAE Flat	2	150924
R11	Pin, Cotter, 1/8 X 1 1/2	4	153861
<b>S</b>	<b>Assembly, Water Valve</b>	<b>1</b>	<b>155458</b>
S1	Fitting, Brass, 1/2 MNPT X Garden Hose Swivel	1	151322
S2	Valve, Shut-Off, 1/2 FNPT X 1/2 FNPT	1	150843
S3	Nut, 1/2 NPT	1	152729
S4	Fitting, Brass, 1/2 MNPT X 3/8 BARB	1	153653
S5	Clamp, 5/8 Hose	2	151198
S6	Hose, 3/8 ID Vinyl	30'	150845
T	Assembly, Lifting Bail (premium only)	1	157853
T1	Lifting Bail	1	157745
T2	Screw, 1/2-13 X 1 1/4 Hex Head Cap	4	153532
T3	Washer, 1/2 Split Lock	4	153524
T4	Washer, 1/2 SAE Flat	8	150924
T5	Nut, 1/2-13 Hex	4	151282
<b>U</b>	<b>Assembly, Water Tank (optional)</b>	<b>1</b>	<b>157852</b>
U1	Tank, Water	1	156644
U2	Cap	1	156956
U3	Valve, Shut Off	1	152075
U4	Elbow, 90°	1	152074
U5	Fitting	1	152076
U6	Tee, 3/8 Hose Barb, Brass	1	156645
U7	Hose, 3/8 I.D. Vinyl	2'	150845
U8	Hose Clamp, 3/8	4	151198

## THEORY OF DIAMOND BLADES

---

Diamond blades do not really cut; they grind the material through friction. Diamond crystals, often visible at the leading edge and sides of the rim/segment, remove material by scratching out particles of hard, dense materials, or by knocking out larger particles of loosely bonded abrasive material. This process eventually cracks or fractures the diamond particle, breaking it down into smaller pieces. As a result, a diamond blade for cutting soft, abrasive material must have a hard metal matrix composition to resist this erosion long enough for the exposed diamonds to be properly utilized. Conversely, a blade for cutting a hard, non-abrasive material must have a soft bond to ensure that it will erode and expose the diamonds embedded in the matrix. These simple principles are the foundation of “controlled bond erosion”



### Types of Cutting

There are two basic types of cutting-Dry or Wet. The choice of which type of blade to use depends on:

- The requirements of the job
- The machine/tool utilizing the diamond blade
- The preference of the operator









In the case of DRY cutting, the overwhelming popularity and quantity of hand-held saws and the flexible nature of MK Diamond blades to professionally handle most ceramic, masonry, stone and concrete materials, make the DRY cutting blade a very attractive tool. When using a DRY blade, the user must be aware of distinct operating practices to ensure optimum performance. DRY cutting blades require sufficient airflow about the blade to prevent overheating of the steel core. This is best accomplished by shallow, intermittent cuts of the material with periods of “free-spinning” (for several seconds) between each cut, to maximize the cooling process.

For WET cutting applications, MK has the exact blade to compliment both the material to be cut and the wet cutting machine to be used. During cutting operations, liberal amounts of water act as a coolant to support the cutting effectiveness and longevity of the WET blade. Additionally, using water adds to the overall safety of cutting operations by keeping the dust signature down.

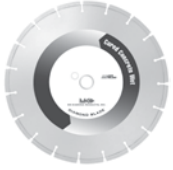
Know All You Can About the Material You Wish to Cut



## ACCESSORIES

ITEM	NUMBER	DESCRIPTION	
1	134965	MK-500 18" x .125 x 1" Standard grade wet cutting blade for cured concrete	
2	129072	MK-505 18" x .125 x 1" Premium grade, wet cutting blade for cured concrete	
3	134965	MK-525 18" x .125 x 1" Supreme grade, wet cutting blade for cured concrete	
4	133850	MK-705W 18" x .142 x 1" Premium grade, wet cutting blade for asphalt	
5	139162	MK-610W 18" x .142 x 1" Supreme grade, wet cutting blade for green concrete	
6	153550	MK-465D 18" x .142 x 1" Premium grade, dry cutting blade for asphalt and green concrete	
7	157852	6.5 Gallon Water Tank	
8	157745	Lifting Bail	

## **ORDERING INFORMATION**

---

You may order MK Diamond products through your local MK Diamond distributor or, you may order direct from MK Diamond.

When ordering direct from MK Diamond, please have the following information ready before calling:

- The Model Number of the saw
- The Serial Number of the saw
- Where the saw was purchased and when
- The Part Number for the part(s) being ordered
- The Part Description for the part(s) being ordered

**NOTE:** There is a \$25.00 minimum order when ordering direct from MK Diamond. A \$5.00 charge will be added to orders having a net billing value under \$50.00. All purchases must be made using VISA, MasterCard or American Express.

All parts may be ordered by calling toll free to – 800 421-5830 or 310 539-5221 and asking for Customer Service. For technical questions, call – 800 474-5594.

## **RETURN MATERIALS POLICY**

---

To expedite the service relative to the return of a product purchased through MK Diamond, please observe the following:

**NOTE:** When returning all items, they must have been purchased within the previous twelve (12) months.

- Have the Model Number of the saw
- Have the Serial Number of the saw
- Have the location of where the saw was purchased
- Have the date when the saw was purchased
- Contact Customer Service for approval to return the item(s)
- Obtain a Returned Goods Number (RGA) authorizing the return
- Follow the packaging instructions in the following section
- Ensure your item(s) are prepaid to the destination

For returned items, call toll free to – 800 421-5830 or 310 539-5221 and ask for Customer Service. For technical questions, call – 800 474-5594 or 310 257-2845.

## **PACKAGING INSTRUCTIONS**

---

- Remove the Cutting Head and Support Angle Assembly
- Dry the saw before shipping
- When packing, include the following: Saw, Diamond Blade, Blade Guard and Support Angle Assembly and Adjustable Cutting Guide (Other Accessories are not required)
- Package the unit in its original container or one of comparable size (do not ship the unit partially exposed)
- Ensure all parts are secured in the packaging to prevent moving

## **AUTHORIZED SERVICE CENTERS**

---

For quicker repair time, you may contact MK Diamond Customer Service, toll free, at 800 421-5830 or 310 539-5221 for the Authorized Service Center closest to you or visit our web site at [www.mkdiamond.com](http://www.mkdiamond.com). For technical questions, call – 800 474-5594.

**CONTACT:**

Please contact MK Diamond Products, Inc. Customer Service Department with any questions you might have regarding distributors, parts or service.

Telephone: **(800) 421-5830**

Fax: **(310) 539-5158**

E-mail: **Customer\_Service@MKDiamond.com**

Customer Service Hours: **Monday through Friday, 6AM-4PM PST**

**MK Diamond Products, Inc.  
1315 Storm Parkway  
Torrance, CA 90501**

**MK DIAMOND PRODUCTS, INC. LIMITED WARRANTY**

MK DIAMOND PRODUCTS, INC. will guarantee every machine they build, to be free from defects in material and workmanship for (1) one year from date of purchase. The obligation of MK DIAMOND PRODUCTS, INC. under this warranty is limited to the repair or replacement of any parts which, under normal use, prove to be defective in material or workmanship. The parts involved or the unit in question should be returned to MK DIAMOND PRODUCTS, INC. or to a point designated by us, transportation prepaid.

This warranty does not obligate us to bear the cost of labor or transportation charges in connection with replacement or repair of defective parts. Likewise, it shall NOT apply to any unit which has been subjected to misuse, neglect or accident. This warranty does NOT apply to any machine which has been repaired or altered outside our factory.

This warranty does NOT obligate MK DIAMOND PRODUCTS, INC., with respect to items not of our manufacture, such as engines, motors, hydraulics, etc., which are subject to their own guarantees and warranties.

We shall in no event be liable for consequential damages or contingent liabilities arising out of failure of any equipment or parts to operate properly.

**© COPYRIGHT 2012, MK DIAMOND PRODUCTS, INC. ALL RIGHTS RESERVED.**

The MK Diamond logo is a registered trademark of MK Diamond Products, Inc. and may not be used, reproduced, or altered without written permission. All other trademarks are the property of their respective owners and used with permission.

MK Diamond may have patents, patent applications, trade marks, copyrights of other intellectual property right covering this product in this document.

This manual MUST accompany the equipment at all times. This manual is considered a permanent part of the equipment and should remain with the unit if resold.

The information and specifications included in this publication were in effect at the time of approval for printing.

**MK-1600 CONCRETE SAW**  
**OWNERS MANUAL & OPERATING INSTRUCTIONS**



**MK Diamond Products, Inc.**

MK Diamond Products, Inc.  
1315 Storm Parkway  
Torrance, CA 90501

Toll-Free: (800) 421-5830  
Phone: (310) 539-5221  
Fax: (310) 539-5158  
[www.mkdiamond.com](http://www.mkdiamond.com)