

MK Diamond Products, Inc.

www.mkdiamond.com

# MK-2000 GAS SERIES MASONRY SAW OWNER'S MANUAL, OPERATING INSTRUCTION & PARTS LIST



Revision 201	11.2014
Manual Part No. 158320	

MK-2005H PART # 155961  
MK-2006R PART # 159885  
MK-2006V PART # 169947  
MK-2007K PART # 167999

**Caution:** Read all safety and operating instructions before using this equipment. This owner's manual **MUST** accompany the equipment at all times.



MK Diamond Products, Inc.

We at MK Diamond want to congratulate you on selecting the saw. We are certain that you will be pleased with your purchase. MK Diamond takes pride in producing the finest products in the industry.

Operated correctly, your saw should provide you with years of quality service. In order to help you, we have included this manual. This Owner's Manual contains information necessary to operate and maintain your saw safely and correctly. Please take a few minutes to familiarize yourself with the saw by reading and reviewing this manual.

Read and follow all safety, operating and maintenance instructions.

If you should have questions concerning your saw, please feel free to call our friendly customer service department at: 800 421-5830

Regards,

MK Diamond

**NOTE THIS INFORMATION FOR FUTURE USE:**

<b>MODEL NUMBER:</b>	
<b>SERIAL NUMBER:</b>	
<b>PURCHASE PLACE:</b>	
<b>PURCHASE DATE:</b>	

**NOTE:** For your (1) one year warranty to be effective, complete the warranty card (including the Serial Number) and mail it in as soon as possible.

<b>SAFETY</b>	<b>Page</b>
Safety Message	4
Rules for Safe Operation	6-7
California Proposition 65 Message	8
Gas Engine Safety	9
Product Specifications	10
Safety Label and Locations	12-13
Unpacking and Contents	14
Transport	15
<b>SETUP, ADJUSTMENT AND OPERATION</b>	
Stand (Optional)	16
Assembly	16-17
Diamond Blade Installation	17
Adjustable Cutting guide Installation	17
Oil Reservoir	18
Filling Fuel Tank	19
Pre-start Inspection	20
Water Pump Setup	21
Setup	22
Operation	22-26
Shutdown	27
Cleanup	27-28
<b>MAINTENANCE</b>	
Maintenance	28-35
Cleaning & Replacing Spark Plug	36-37
Micro-V Belt Inspection	37-41
<b>TROUBLESHOOTING</b>	
Blade Will Not Cut Properly	41
Movable Cutting Table Does Not Move	42
Cooling Flow	42-43
Blade Stops Turning	44
Engine Stops	44
<b>EXPLODED VIEW AND PARTS LIST</b>	
Exploded View & Parts List	46-56
<b>ACCESSORIES</b>	
Accessories	57
<b>ORDERING, RETURNING INSTRUCTIONS, CONTACT, and LIMITED WARRANTY</b>	
Ordering Information, Return Material Policy, Packaging & Service Center	58-59

Read and follow all safety, operating and maintenance instructions. Failure to read and follow these instructions could result in injury or death to you or others. Failure to read and follow these instructions could also result in damage and/or reduced equipment life. Safety warnings and guidelines do not by themselves eliminate danger. They are not substitutes for proper accident prevention procedures and good judgement.

### SAFETY MESSAGES

A safety message alerts you to potential hazards that could hurt you or others. Each safety message is preceded by a safety alert symbol (  ) and one of three words: **DANGER**, **WARNING**, or **CAUTION**.



**DANGER** You **WILL** be **KILLED** or **SERIOUSLY INJURED** if you **DO NOT** follow directions.



**WARNING** You **CAN** be **KILLED** or **SERIOUSLY INJURED** if you **DO NOT** follow directions.



**CAUTION** You **CAN** be **INJURED** if you **DO NOT** follow directions. It may also be used to alert against unsafe practices.

### DAMAGE PREVENTION AND INFORMATION MESSAGES

A Damage Prevention Message is to inform the user of important information and/or instructions that could lead to equipment or other property damage if not followed. Information Messages convey information that pertains to the equipment being used. Each message will be preceded by the word **NOTE**, as in the example below.

**NOTE:** Equipment and/or property damage may result if these instructions are not followed.

### GENERAL SAFETY PRECAUTIONS AND HAZARD SYMBOLS

In order to prevent injury, the following safety precautions and symbols should be followed at all times!

#### SAFETY PRECAUTIONS



**ALWAYS** read this Owner's Manual before operating the machine. **DO NOT** operate or service this equipment before reading this entire manual. Read and understand all warnings, instructions and controls on the machine. Know how to stop the equipment quickly in case of emergency. It is the operators responsibility to use this machine under safe working conditions and conform with federal, state and local codes or regulations pertaining to safety, air, pollution, noise etc...



**ALWAYS** keep the Blade and Belt Guards in place. **DO NOT** operate this machine with any guard or safety device removed. A Guard, or any damaged part should be repaired or replaced immediately.

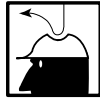

**NEVER** operate this equipment without proper protective clothing, shatterproof glasses, steel-toed boots and other protective devices required by the job. Non-slip foot wear is recommended.

**PERSONAL PROTECTIVE EQUIPMENT**

**ALWAYS** wear approved respiratory, head, ear and eye protection when operating this machine.

**ACCIDENTAL STARTS!**

Before starting the engine/motor, be sure the **ON/OFF** switch is in the **OFF** position to prevent accidental starting. Place the **ON/OFF** switch in the **OFF** position before performing any service operation. **ALWAYS** place the power **ON/OFF** switch in the **OFF** position when the machine is not in use.

**ROTATING PARTS**

Keep hands, feet, hair, and clothing away from all moving parts to prevent injury. Never operate the motor with covers, shrouds, or guards, removed.

**HOT PARTS!**

Engine components can become extremely hot from operation. To prevent severe burns, do not touch these areas while the engine is running, or immediately after it is turned off. Never operate the engine with heat shields removed.

**OVER SPEED**

**NEVER** tamper with the governor components or settings to increase the maximum speed. Severe personal injury and damage to the engine or equipment can result if operated at speeds above maximum.

**ELECTRICAL SHOCK**

**NEVER** touch electrical wires or components while the engine is running. Exposed, frayed or worn electrical wiring and plugs can be sources of electrical shock which could cause severe injury or burns. Do not touch the plug with wet hands.



**ALWAYS** avoid inhalation of and skin contact with silica dust and/or mist. Provide proper dust removal. Use dust-collection system when applicable.



**NEVER** operate the machine in an explosive atmosphere or near combustible materials. Sparks from the cutting-action of this machine can ignite flammable materials, liquids, gases or dust.



This equipment should not be operated by persons under 18 years of age.

**KEEP CHILDREN AWAY**

All visitors and children should be kept a safe distance from work area. Maintain a safe operating distance to other personnel.

**MAKE THE WORKSHOP KID PROOF**

Make the workshops kid proof by using padlocks, master switches or by removing starter keys.

**DO NOT FORCE THE TOOL**

A power tool will do a job better and safer operating at the rate for which it was designed. **DO NOT** force a tool or an attachment to do a job that it was not designed to do.

**USE PROPER APPAREL**

**DO NOT** wear loose clothing, gloves, neckties, rings, bracelets, or other jewelry that may be caught in moving parts. Non-slip footwear is recommended. Wear protective hair covering to contain long hair.

**SECURE WORK**

Clamps or a vise should be used to hold work whenever practical. Keeping your hands free to operate a power tool is safer.

**DO NOT OVERREACH**

Keep proper footing and balance at all times by not overreaching.

**DISCONNECT TOOLS**

Power tools should always be disconnected before servicing, adjusting or when changing accessories, such as blades, bits, cutters, and the like.

**MAINTAIN TOOLS WITH CARE**

Keep tools clean and maintained for the best and safest performance. Always follow maintenance instructions and examine the machine before use. If any abnormal vibrations or noises occurs, turn off machine immediately and have the problem corrected before further use.

**REMOVE ADJUSTING KEYS AND WRENCHES**

Form a habit of checking to see that keys and adjusting wrenches are removed from the power tool before it is turned on.

**KEEP WORK AREA CLEAN**

Cluttered work areas and benches invite accidents. Keep area around machine clear of obstructions which could cause persons to fall.

**DO NOT USE IN DANGEROUS PLACES**

**DO NOT** operate equipment in dangerous or hazardous environments. **DO NOT** use power tools in damp or wet locations nor expose them to rain. Always keep the work area well lighted.

**USE RECOMMENDED ACCESSORIES**

Consult the owner's manual for recommended accessories. Using improper accessories may increase the risk of personal or by-stander injury. Unauthorized equipment modifications will void all warranties. Manufacturer does not assume responsibility for any accident due to equipment modifications.



**ALWAYS** ensure that the machine is on level ground before using.

**NEVER STAND ON THE TOOL**

Serious injury could occur if a power tool is tipped, or if a cutting tool is unintentionally contacted.

**TRANSPORT**

When loading or unloading the machine, use caution. Remove the blade prior to hoisting, loading and transporting the machine.

**CHECK FOR DAMAGED PARTS**

Before using a power tool, check for damaged parts. A guard or any other part that is damaged should be carefully checked to determine if it would operate properly and perform its intended function. Always check moving parts for proper alignment or binding. Check for broken parts and mountings and all other conditions that may affect the operation of the power tool. A guard, or any damaged part, should be properly repaired or replaced. Always check the machine for loose bolts before starting.

**DIRECTION OF ROTATION**

A blade or cutter should always be installed so that rotation is in the direction of the arrow imprinted on the side of the blade or cutter. It should correspond with the rotational direction of the motor. Always feed work into a blade against the direction of rotation.

**NEVER LEAVE A TOOL UNATTENDED**

**TURN POWER OFF** - Do not leave a tool until it comes to a complete stop. **ALWAYS** turn a power tool **OFF** when leaving the work area, or, when a cut is finished.



**NEVER** disconnect any "emergency or safety devices". These devices are intended for operator safety. Disconnection of these devices can cause severe injury, bodily harm, or even death! Disconnection of any of these devices will void all warranties. Unauthorized equipment modifications will void all warranties. Manufacturer does not assume responsibility for any accident due to equipment modifications.



**NEVER** use this machine with any cutter designed for woodworking.



**NEVER** operate this equipment when not feeling well due to fatigue, illness or taking medicine.



**NEVER** operate this equipment under the influence of drugs or alcohol.



On belt driven equipment, overtensioning of belts will result in premature crank and/or bearing failure.



Whenever necessary, replace nameplate, operation and safety decals when they become difficult to read.



**ALWAYS** store equipment properly when it is not being used. Equipment should be stored in a clean, dry location out of the reach of children



**DO NOT** lend or rent this equipment without including the Owner's Manual and the Engine/Motor Manufacturer's Manual.



Check the chemical properties of the material to be cut/grinded and follow all EPA/OSHA Regulations.

## **SILICA DUST WARNING**

---

Grinding/cutting/drilling of masonry, concrete, metal and other materials with silica in their composition may give off dust or mists containing crystalline silica. Silica is a basic component of sand, quartz, brick clay, granite and numerous other minerals and rocks. Repeated and/or substantial inhalation of airborne crystalline silica can cause serious or fatal respiratory diseases, including silicosis. In addition, California and some other authorities have listed respirable crystalline silica as a substance known to cause cancer. When cutting such materials, always follow respiratory precautions.

Use appropriate NIOSH-approved respiratory protection where dust hazard may occur. Paper masks or surgical masks without a NIOSH approval number are not recommended because they do little to protect the worker. For more information about respirator programs, including what respirators have received NIOSH approval as safe and effective, please visit the NIOSH website at:  
<http://www.cdc.gov/niosh/topics/respirators>

Observe OSHA regulations for respirator use (29 C.F.R. §1910.134).  
Visit <http://www.osha.gov> for more information.

## **CALIFORNIA PROPOSITION 65 MESSAGE**

---

Some dust created by power sanding, sawing, grinding, drilling, and other construction activities contain chemicals known (to the State of California) to cause cancer, birth defects or other reproductive harm. Some examples of these chemicals are:

- Lead, from lead-based paints
- Crystalline silica from bricks, cement and other masonry products
- Arsenic and chromium, from chemically treated lumber

For further information, consult the following sources:  
<http://www.osha.gov/dsg/topics/silicacrystalline/index.html>  
<http://www.cdc.gov/niosh/docs/96-112/>  
<http://oehha.ca.gov/prop65/law/P65law72003.html>  
<http://www.dir.ca.gov/Title8/sub4.html>

Your risk from these exposures varies depending on how often you do this type of work. To reduce your exposure to these chemicals, work in a well-ventilated area, and work with approved safety equipment, such as dust masks that are specially designed to filter out microscopic particles. Where use of a dust extraction device is possible, it should be used. To achieve a high level of dust collection, use an industrial HEPA vacuum cleaner. Observe OSHA 29 CFR part 1926.57 and 1926.103.



### **WARNING**

Sawing, grinding and drilling generate dust. Excessive airborne particles may cause irritation to eyes, skin and respiratory tract. To avoid breathing impairment, always employ dust controls and protection suitable to the material being sawed or drilled; See OSHA (29 CFR Part 1910.1200).



## GAS ENGINE SAFETY

---

Gasoline models are shipped from the factory dry, meaning without fuel or oil. Both must be added before equipment can be used. Check the engine Manufacturer Owner's Manual for instructions on fueling, break-in, servicing and proper engine care and use.

## GAS SAFETY PRECAUTIONS

---



### EXPLOSIVE FUEL!

Gasoline is extremely flammable, its vapors can explode if ignited; store only in approved containers, in well-ventilated, unoccupied buildings and away from sparks or flames. **DO NOT** fill the fuel tank while the engine is running or hot. Spilled fuel could ignite if it contacts hot parts or sparks from ignition. **DO NOT** overfill tank. **DO NOT** start the engine near spilled fuel. Never use gasoline as a cleaning agent.



Refer to engine manufacturer manual for specific operating procedures and safety warnings. **ALWAYS** check the fuel lines and fuel tanks for leaks and cracks before starting the engine. **DO NOT** run the machine if fuel leaks are present or the fuel lines are loose.



Accidental start hazard. Disconnect spark plug prior to servicing.



### LETHAL EXHAUST GASES!

Engine exhaust gasses contain poisonous carbon monoxide (an odorless, colorless gas). Avoid inhaling exhaust fumes Breathing it can cause unconsciousness and even kill you. Always operate gasoline engine machines in a well-ventilated area. **DO NOT** operate in areas where exhaust fumes could accumulate without wearing appropriate respiratory protection. Never run the engine in a closed building or confined area.

**NOTE:** Prior to operation of this machine the operator must determine the existence and location of any sub-surface features that may be hazardous or could damage the equipment, (i.e. electric cable, natural gas line etc.).

## FUELING SAFETY

---

**ALWAYS** use caution when handling fuel. Shut off the engine and allow to cool before refueling.



**ALWAYS** refill fuel tank in a well-ventilated area.



**ALWAYS** replace the fuel tank cap after refueling.



**ALWAYS** close fuel value on engines when machine is not being operated.

Move the machine at least 10 feet (3 meters) from the fueling point before starting the engine, and make sure the gas cap is on the machine and the fuel can is properly tightened.

**PRODUCT SPECIFICATIONS**

Operated and used according to this manual, the MK-2000 Gas Saws will provide years of dependable service.

**GENERAL DESCRIPTION**

The MK-2000 Gas Saws are engineered as portable brick saws powered by either a Honda, Robin, Kohler or Vanguard engine. The saw is capable of cutting masonry up to five (5) inches (127 mm) in height, sixteen (16) inches in length in a single pass.

**SPECIFICATIONS**

Motor specifications for the MK-2000 Series Saw are listed below.

	<b>MK-2005H</b>	<b>MK-2006R</b>	<b>MK-2007K</b>	<b>MK-2006V</b>
<b>Motor/Engine</b>	Honda	Subaru	Kohler	Vanguard
<b>Power</b>	GX160	SP210	CH270	13H3
<b>Blade Capacity</b>	14" (356mm)	14" (356mm)	14" (356mm)	14" (356mm)
<b>Arbor Size</b>	1" (25mm)	1" (25mm)	1" (25mm)	1" (25mm)
<b>Length of Cut</b>	16" (406mm)	16" (406mm)	16" (406mm)	16" (406mm)
<b>Depth of Cut</b>	5" (127mm)	5" (127mm)	5" (127mm)	5" (127mm)
<b>Shipping Method</b>	Truck	Truck	Truck	Truck
<b>Motor RPM</b>	3,600	3,600	3,600	3,600
<b>Blade RPM</b>	2,550	2,550	2,550	2,550
<b>L x W x H</b>	42" x 24" x 39"	42" x 24" x 39"	42" x 24" x 39"	42" x 24" x 39"
<b>L x W x H (mm)</b>	1067 x 610 x 991	1067 x 610 x 991	1067 x 610 x 991	1067 x 610 x 991
<b>Weight</b>	171 lbs (77.5 kg)	171 lbs (77.5 kg)	171 lbs (77.5 kg)	171 lbs (77.5 kg)
<b>Part #</b>	155961	159885	167999	169947

**ENGINE SPECIFICATIONS**

Engine power ratings are calculated by the individual engine manufacturer and the rating method may vary among engine manufacturers. Users are advised to consult the engine manufacturer's owner's manual and website for specific information regarding engine power rating and maintenance.

**BLADE CAPACITY**

The MK-2000 Gas Saw is designed for use with a 14-inch diameter segmented wet or dry MK Diamond blade with a .110 to .375 inch cutting width.

**MASONRY TYPES**

The MK-2000 Gas Saw can cut a variety of masonry types including, cinder block, slump stone block, wall brick, paver brick, concrete block and cylinders, roofing tile, marble, granite, decorative rock or almost any other non-ferrous material.

**NOTE:** The MK-2000 Gas Saw is not designed to cut plastic or metals.

**SPRING ASSISTED CUTTING HEAD**

The MK-2000 Gas Saw is designed with a spring-assisted cutting head to allow for easier step cutting. The Cutting Head can be locked in the down position when cutting smaller pieces.



**OPERATION & SAFETY DECALS**

The MK-2000 Gas Saw is equipped with a number of safety decals provided for operator safety and maintenance information. Should any of these decals become unreadable, replacements can be obtained by calling (800) 262-1575.

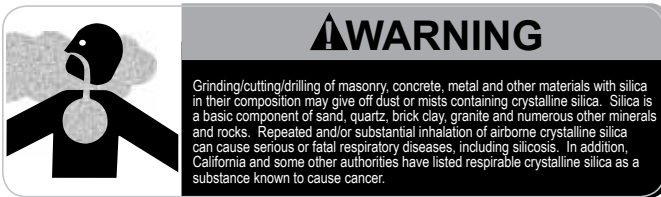

Decal A



Decal B



Decal C



Decal D



Decal E



Decal F



Decal G

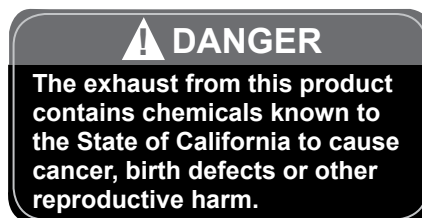

Decal H



Decal I

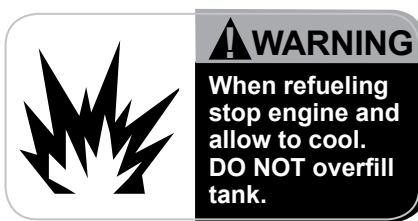

Decal J



Decal K



Decal L

Masonry Safety Decal Sheet, Part No. 166011

## SAFETY DECAL LOCATIONS

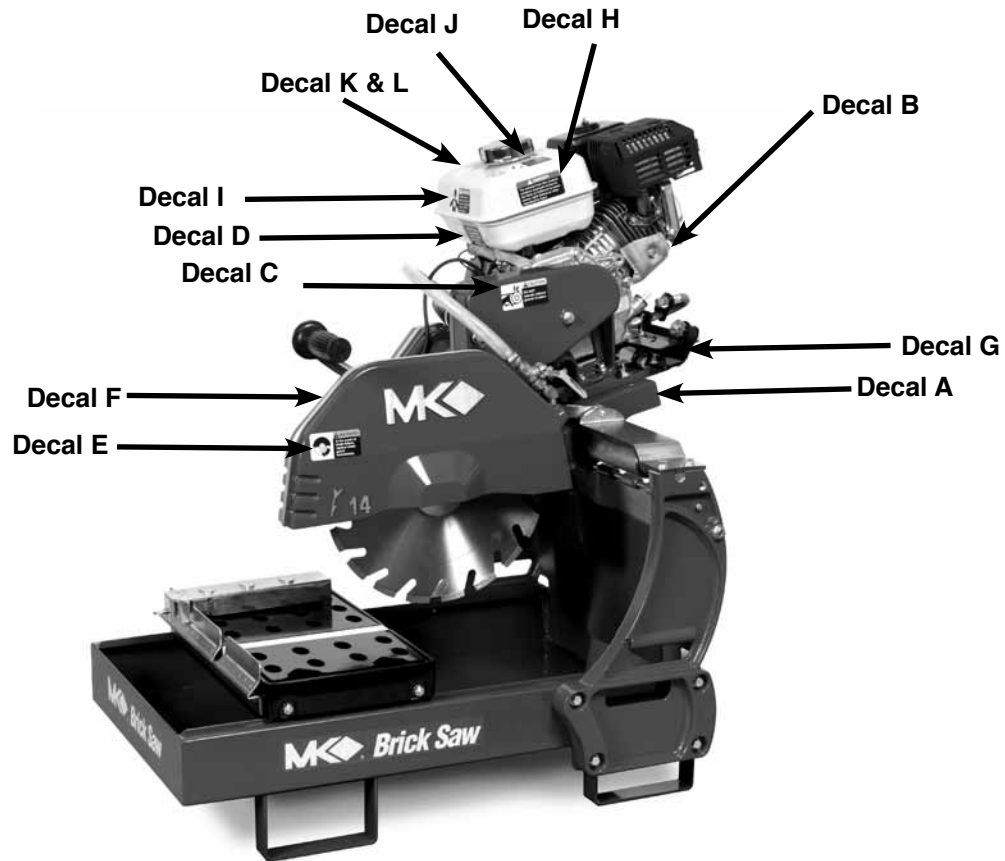

Fig. 4 MK-2000 Safety Decal Locations

Decal	Location	Description
A	Motor - Back	Warning - Silica
B	Motor - Rear	Service or Warranty Information
C	Belt Guard	Caution - General Safety Information
D	Motor - Front	Warning - Read Manual
E	Blade Guard	Warning - Replace Blade Guard
F	Blade Guard	Caution - General Safety Information
G	Motor - Back	Caution - Accidental Start Hazard
H	Motor - Side	Danger - State of California
I	Motor - Front	Danger - Lethal Exhaust/Cancer
J	Motor - Top	Warning - Refueling
K	Motor - Side	Caution - Do Not Touch Hot Surface
L	Motor - Side	QR Code

**UNPACKING**

Your MK-2000 Gas Saw has been shipped from the factory thoroughly inspected. Only minimal assembly is required.



**CAUTION**

Use proper lifting techniques when lifting the MK-2000 Gas Saw.

**CONTENTS**

In your container, you will find one (1) MK-2000 Gas Saw, one (1) diamond blade, one (1) cutting table, one (1) adjustable cutting guide, one (1) drain plug, one (1) blade wrench, one (1) owner's manual, one (1) engine manual and one (1) warranty card.



MK-2000 Gas Saw

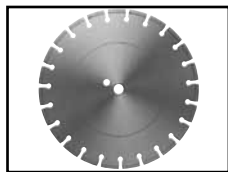

Diamond Blade

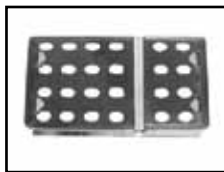

Movable Cutting Table



Adjustable Cutting Guide



Drain Plug



Blade Wrench



Owner's Manual



Engine Manual



Warranty Card

**TRANSPORT**

The MK-2000 Gas Saw weighs approximately 200 pounds; two people are required when transporting the saw.

**CAUTION**

1. Never transport the MK-2000 Gas Saw with water in the Water Basin.
2. The MK-2000 Gas Saw weighs approximately 200 pounds; two people are required when lifting or moving.

**NOTE:** Lock the Cutting Head in the DOWN position, and remove the movable Cutting Table when transporting the MK-2000 Gas Saw.

The MK-2000 Gas Saw is designed with recessed handles in the right and left upright castings or forklift brackets on the bottom for ease of transport.

To transport –

- Verify the movable Cutting Head is locked in the down position and the movable Cutting Table is removed
- Grasp the saw by the recessed handle in the right and left upright castings
- Grasp the front of the saw
- Lift and transport the saw to the desired work location

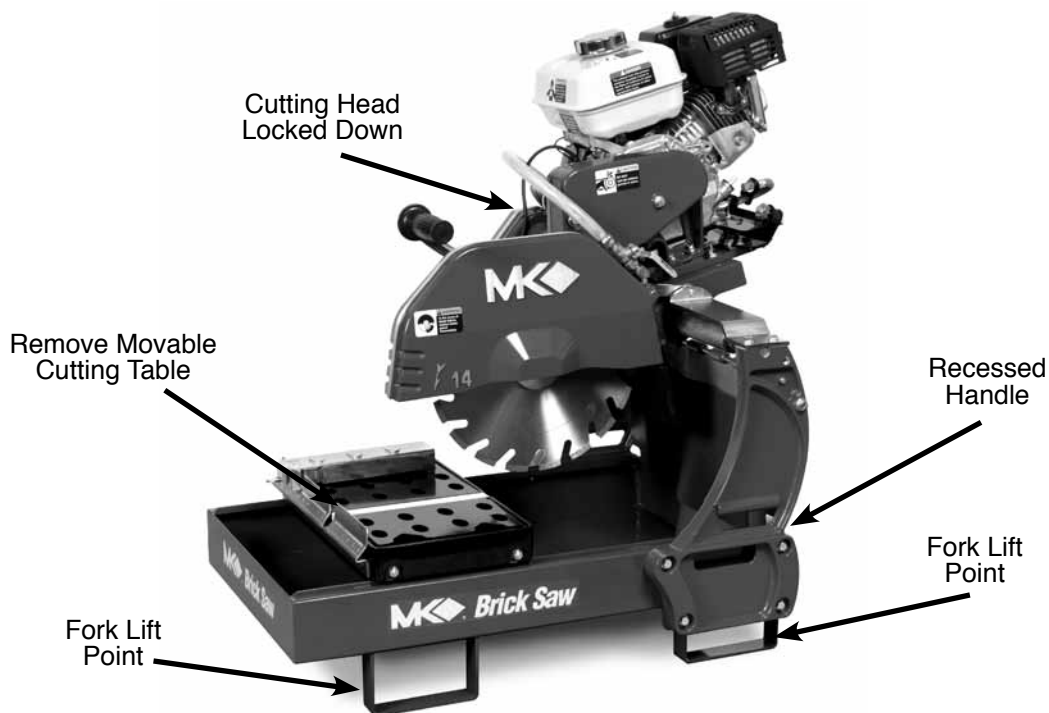

**STAND (Optional)**

**NOTE:** If using the MK Diamond Stand (Part# 153331), follow these steps.



(A)  
Open the stand and place it on flat surface.



(B)  
Set saw on stand as shown.



(C)  
Ensure pins are placed through holes on frame

**MOVABLE CUTTING TABLE INSTALLATION**



(A)  
While holding the front, position movable Cutting Table roller wheels above Guide Rails



(B)  
Seat movable Cutting Table roller wheels on saw Guide Rails

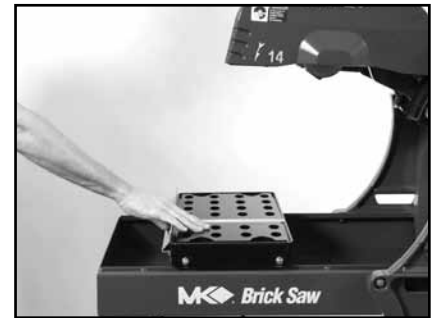

(C)  
Verify movable Cutting Table is seated correctly by moving table back and forth.



**DIAMOND BLADE INSTALLATION**



**CAUTION**

The Cutting Head will rotate upward, when you loosen Cutting Head Lock, hold the saw by the handle and control the upward movement.

**NOTE:** The Cutting Head is locked in the down position when shipped from the factory.

**NOTE:** When installing the diamond blade retaining-bolt, ensure the threads of the bolt are aligned with the threads of the blade shaft so as not to “cross-thread” the bolt.



(A)  
Raise Cutting Head by loosening Cutting Head Lock



(B)  
Identify and remove Retaining Screw and Outer Flange



(C)  
Install Diamond Blade onto Blade Shaft

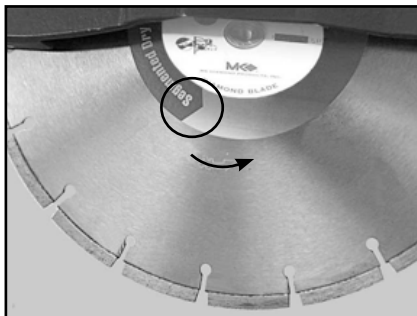

(D)  
Verify Blade is seated on Blade Shaft in correct rotation direction.

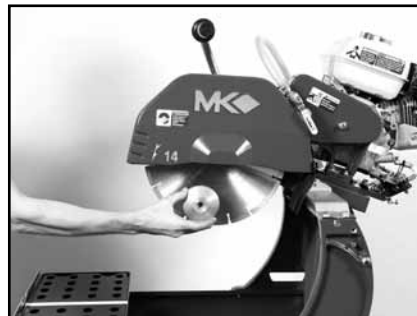

(E)  
Install Outer Flange.



(F)  
Install Retaining Screw then tighten.

**ADJUSTABLE CUTTING GUIDE INSTALLATION**

**NOTE:** The adjustable Cutting Guide can be used on either side of the Diamond Blade.



(A)  
Loosen adjustable Cutting Guide retaining thumbscrews by turning counter-clockwise.



(B)  
Position adjustable Cutting Guide above movable Cutting Table. Align parallel slots. Seat and tighten the adjustable Cutting Guide retaining thumbscrew.

**FILLING OIL RESERVOIR**

**NOTE:** Refer to the Engine Manual for your specific engine.



(A)  
Level Cutting Head and motor.

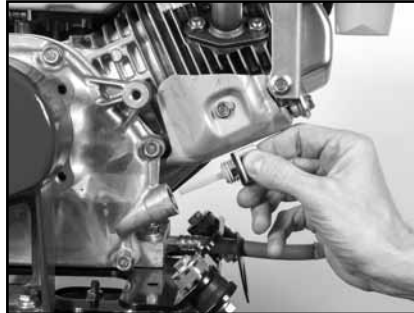

(B)  
Remove Dipstick.



(C)  
Fill Oil Reservoir.

**NOTE:** When installing the Oil Dipstick, ensure the threads are aligned with the threads of the Oil Reservoir so as not to “cross-thread” the dipstick.

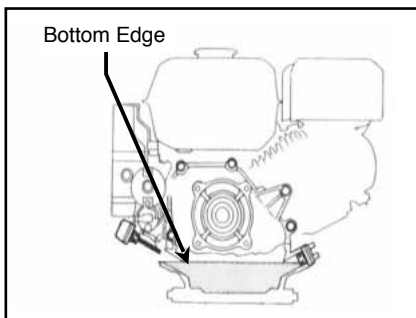

(D)  
Add Oil until level reaches the bottom edge of fill hole.

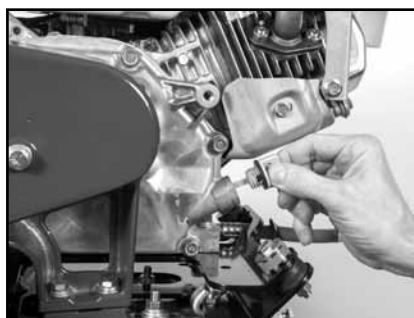

(E)  
Install Dipstick.



(F)  
Clean up.

## FILLING FUEL TANK



- WARNING**
1. Gasoline is highly flammable and explosive. You can be burned or seriously injured when handling fuel.
  2. To fuel, stop engine if running, and allow it to cool.
  3. Refuel in a well-ventilated area.
  4. Keep gasoline away from appliance pilot lights, barbecues, electric appliances, power tools, etc.
  5. Wipe up spills immediately.

- NOTE:**
1. Fuel can damage paint and plastic. Be careful not to spill fuel when filling the fuel tank. Damage caused by spilled fuel IS NOT covered under the warranty.
  2. DO NOT use stale or contaminated gasoline, or an oil/gasoline mixture.
  3. If using a stand with the MK-2000 Gas Saw, a ladder meeting OSHA specification is recommended.
  4. Use unleaded gasoline with a pump octane rating of 86 or higher.

**NOTE:** Refer to the Engine Manual for your specific saw.



(A)  
Remove Fuel Cap.



(B)  
Fill Fuel Tank.

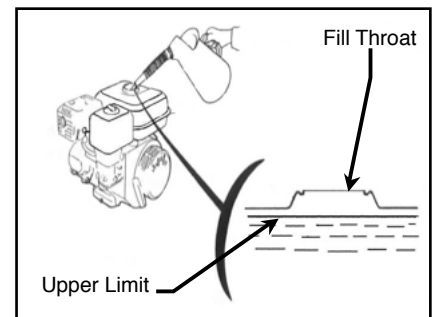

(C)  
Verify fuel level is below the throat of the Fuel Tank.

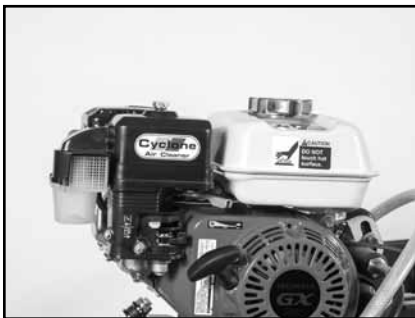

(D)  
Install Fuel Cap.

**PRE-START INSPECTION**

The pre-start inspection should be performed before beginning any job. The operator must be aware of the machines capabilities and limitations. It is the operators responsibility to use this machine under safe working conditions and conform with federal, state and local codes or regulations pertaining to safety, pollution, noise, etc...



**CAUTION** If the Diamond Blade shows signs of fatigue cracking, replace the blade before starting work.

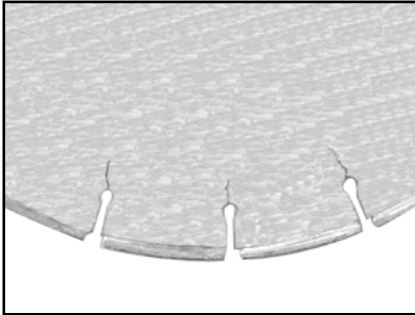

(A)  
Inspect Blade for damage –  
Verify Blade correct for material  
being cut.



(B)  
Inspect Wooden Strip for  
excessive grooves.

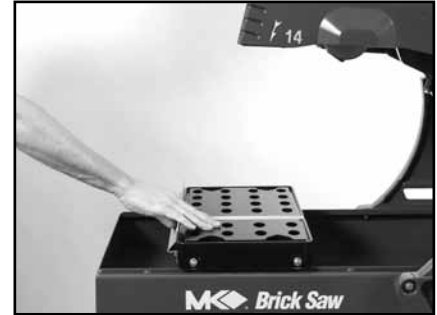

(C)  
Verify movable Cutting Table  
moves freely.



(D)  
Inspect Engine for leaks.



(E)  
Inspect MK-2000 Gas Saw for  
general damage, loose connec-  
tions and hardware.

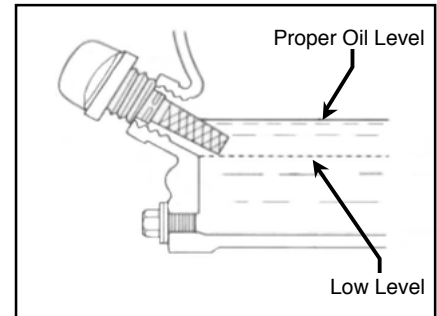

(F)  
Check for proper oil level.  
(See Engine Manual if low)

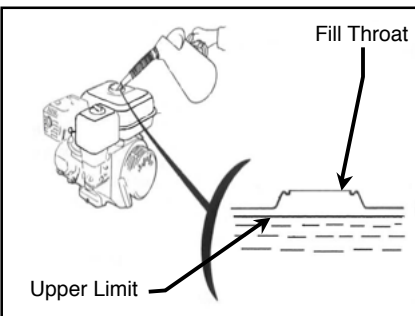

(G)  
Check for proper fuel level.  
(See Engine Manual if low)



(H)  
Check Air Filter for cleanliness.  
(See Engine Manual)

**WATER PUMP SETUP**

The Water Pump can be setup in three ways, External Water Source, Re-circulation or Un-coupled for dry blade operation.

**NOTE:** To extend the life of the Diamond Blade and Water Pump, MK Diamond recommends a clean cooling water source when using a Wet Diamond Blade.

**EXTERNAL WATER SOURCE**

This is the preferred method of cooling when using a “wet” diamond blade.



(A)  
Remove the Drain Plug and place a catch basin below the drain hole.



(B)  
Remove Water Pump from clamp.



(C)  
Place the Water Pump Assembly into a filled Water Container.

**RE-CIRCULATION**

**NOTE:**

1. Water Pump could interfere with masonry being cut.
2. Water should be periodically replaced when using this method.



(A)  
Install the Drain Plug and fill Water Basin.

**DRY BLADE OPERATION**

**ALWAYS** avoid inhalation of and skin contact with silica dust and/or mist.

**NOTE:** Failure to perform the following steps will lead to premature pump failure.



(A)  
Move Water Pump Assembly  
to the outside of the  
Water Basin.

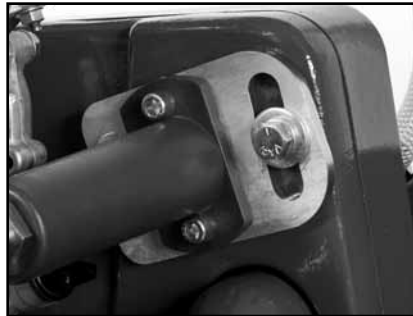

(B)  
Identify Water Pump Drive  
End Pivot Plate.

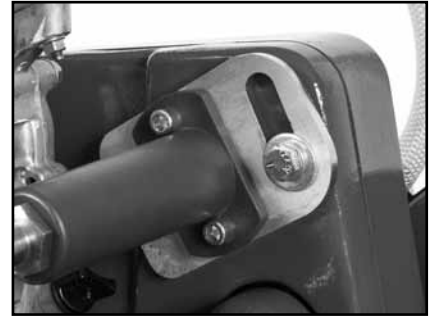

(C)  
Pivot front of Water Pump Drive  
End Pivot Plate up and tighten  
the retaining bolts.



(D)  
Loosen Water Pump Drive  
End Pivot Plate front and rear  
retaining bolts.

**ENGINE START**

Refer to Engine Manual for proper engine operation of your specific saw.

**DANGER**

1. Carbon monoxide gas is toxic. Breathing it can cause unconsciousness and/or death. Use only in well ventilated areas. DO NOT use indoors.
2. Avoid any areas or actions that expose you to carbon monoxide.

**STEP CUTS**

A Step Cut is performed when a series of small cuts of increasing depth are used to complete a single cut. Step Cuts are used for large objects or for hard objects such as firebrick and pavers.

- NOTE:**
1. Step Cutting is the preferred cutting method for all cuts.
  2. When cutting hard material Step Cutting should always be used.
  3. Step Cutting will extend the life of the Diamond Blade.



**CAUTION DO NOT FORCE TOOL**, it will do the job better and safer at the rate for which it was designed.

**NOTE:** Skip steps C and D, if cutting dry.



(A)  
Set the adjustable Cutting Guide.

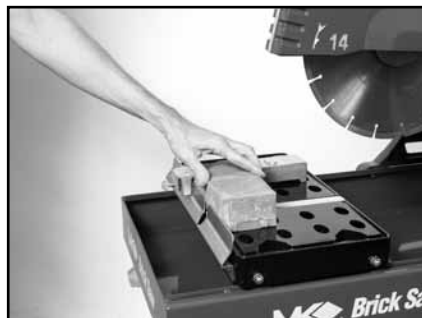

(B)  
Position the masonry piece.

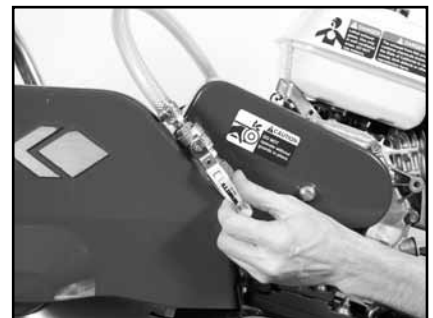

(C)  
Open the Cooling Flow Control Valve and adjust flow. Verify cooling flow exists on both sides of the blade.



(D)  
Move the Throttle Lever to adjust blade speed. Refer to Engine Manual for your specific engine.

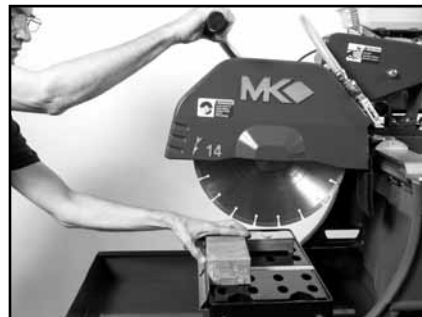

(E)  
Setup to Cut.

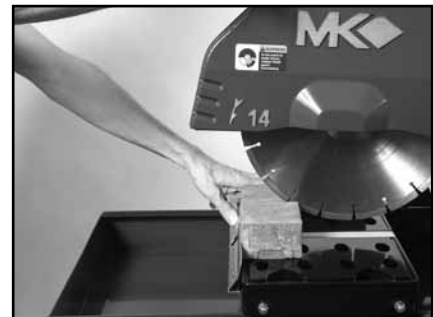

(F)  
Step Cut "Push" stroke.

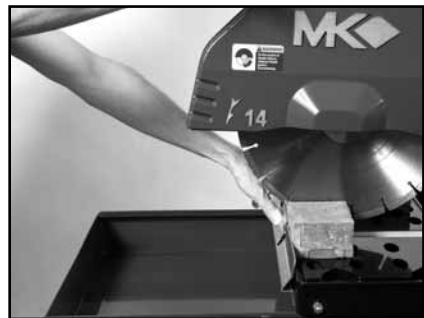

(G)  
Step Cut "Pull" stroke. Lower blade 1/4" - 1/2" inch.



(H)  
Repeat steps F and G until cut is complete.

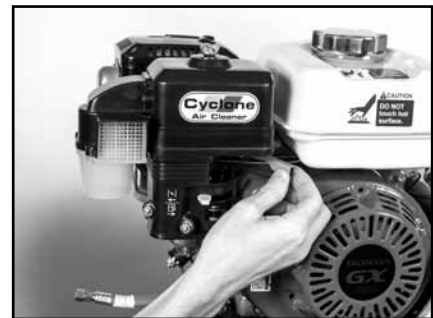

(I)  
Move the Throttle Lever to lower blade speed. Refer to Engine Manual for your specific engine.

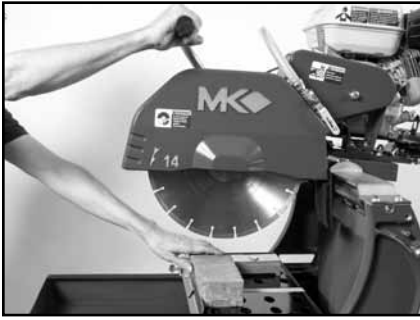

(J)

Raise Cutting Head once cut is complete and turn OFF saw. Refer to engine Manual for complete shutdown procedures.

**CHOP CUTTING**

A Chop Cut is performed by cutting completely through an object in one pass.



**CAUTION DO NOT FORCE TOOL**, it will do the job better and safer at the rate for which it was designed.

**NOTE:** Note: Skip step C, if cutting dry.



(A)

Set the adjustable Cutting Guide.

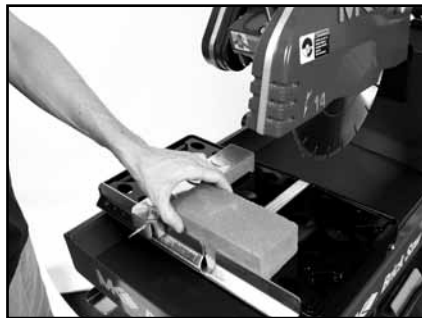

(B)

Position the masonry piece.

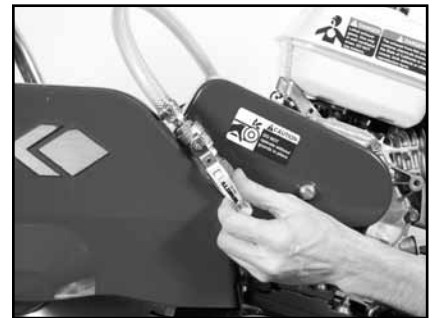

(C)

Open the Cooling Flow Control Valve and adjust flow. Verify cooling flow exists on both sides of the blade.



(D)

Move the Throttle Lever to adjust blade speed. Refer to your specific Engine Manual.

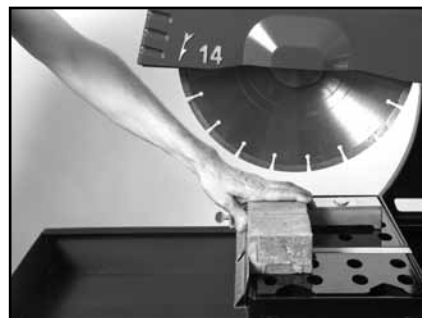

(E)

Setup to Cut.

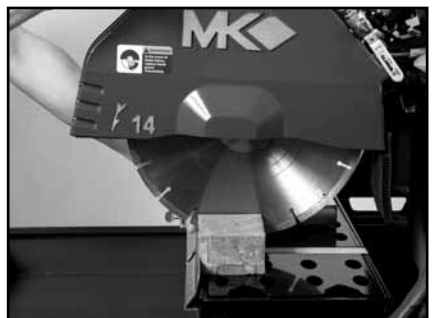

(F)

Lower Cutting Head to begin the cut.



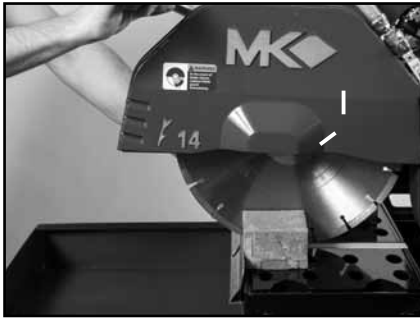

(G)  
Continue lowering the Cutting Head until the cut is complete.



(H)  
Move the Throttle Lever to lower blade speed.

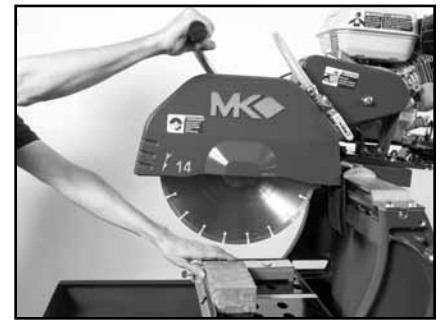

(I)  
Raise Cutting Head once cut is complete and turn OFF saw. Refer to Engine Manual for complete shutdown procedures.

Refer to the Engine Manual for complete shut down procedure.

**CUTTING WITH THE CUTTING HEAD LOCKED DOWN**

This method is preferred when cutting small objects.



**CAUTION DO NOT FORCE TOOL**, it will do the job better and safer at the rate for which it was designed.

**NOTE:** Skip step D, if cutting dry.



(A)  
Set the adjustable Cutting Guide.



(B)  
Position the masonry piece.



(C)  
Lock Cutting Head in the down position.



(D)  
Open the Cooling Flow Control Valve and adjust flow. Verify cooling flow exists on both sides of the blade.

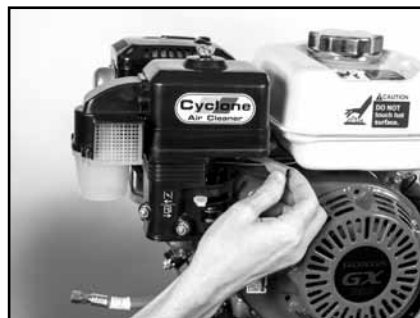

(E)  
Move the Throttle Lever to adjust blade speed (faster blade speed for smoother cuts) Refer to Engine Manual for your specific engine.

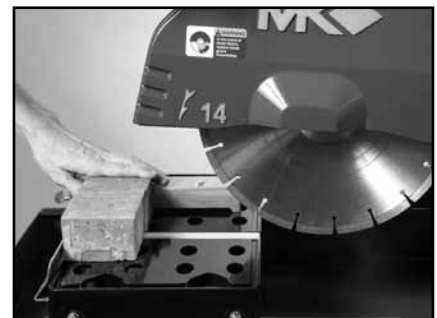

(F)  
Setup to Cut.

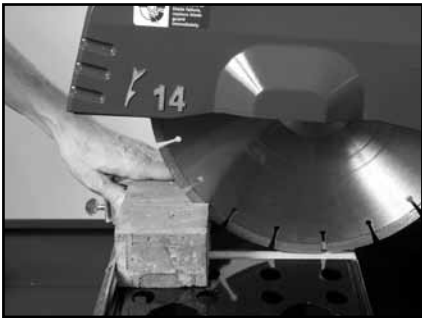

(G)  
Slowly push piece toward the blade – continue until the cut is complete.

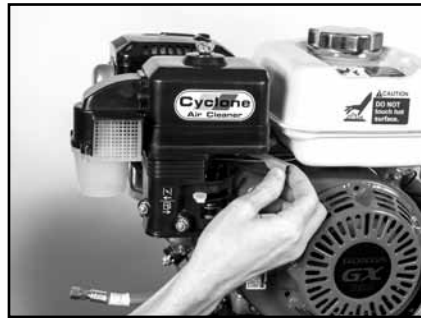

(H)  
Move the Throttle Lever to lower blade speed. Refer to your specific engine manual. Turn OFF saw.



(I)  
Unlock Cutting Head.



(J)  
Raise Cutting Head and lock into place. Refer to Engine Manual for complete shutdown procedure.

**NORMAL ENGINE SHUTDOWN**

**NOTE:** Refer to engine manual for proper engine operation of your specific saw.



(A)  
Move the Throttle Lever to lower blade speed.



(B)  
Place Engine Switch in the OFF position. Refer to Engine Manual for complete shut down procedure.

**EMERGENCY ENGINE SHUTDOWN**

**NOTE:** Refer to engine manual for proper engine operation of your specific saw.



(A)  
Place Engine Switch in the OFF position.



(B)  
Move the Throttle Level to lower blade speed. Refer to your specific Engine Manual.



(C)  
Place Fuel Valve in the OFF position.

**CLEANUP****CAUTION**

Engine parts are extremely hot following use, allow engine to cool 1/2-hour before cleaning. Use care during cleanup to avoid injury.

**NOTE:** If a clean external water source was used, steps A to C may be skipped.

1. To extend operating life, the MK-2000 Gas Saw should be cleaned following every use.
2. Using a garden hose or pressure washer can force water into the air cleaner or muffler opening.
3. Use care when cleaning around electrical components.

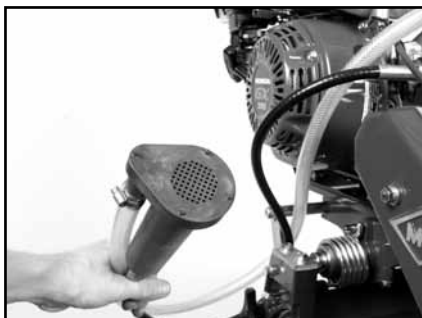

(A)  
Clean Water Pump suction of all debris.



(B)  
Place Water Pump in a container of clean water. Run MK-2000 Gas Saw until clear water is seen at blade cooling ports (Approx. 1 minute).



(C)  
Place Engine Switch in the OFF position. Turn OFF saw. Refer to Engine manual for complete shut down procedure.



(D)

Clean Water Basin and Movable Cutting table Guide Rails with soap and clean water.



(E)

Clean Movable Cutting table Roller Wheels.

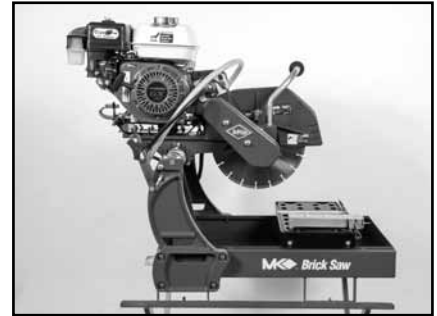

(F)

Clean exterior surface of MK-2000 Gas Saw (except engine) with soap and clean water.

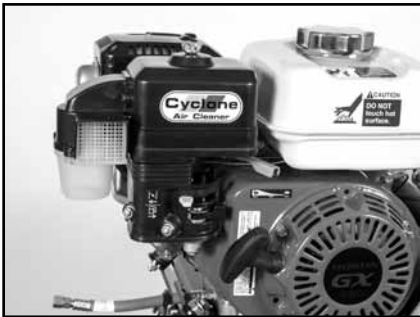

(G)

Clean Air Filter and other engine parts. Refer to Engine Manual for your specific engine.

**MAINTENANCE**

Periodic maintenance including cleaning, lubrication, tensioning of drive belts, and inspection for wear and damage are routine servicing procedures. These procedures can prevent serious damage or malfunctioning of the machine and aid in preserving the useful life of saw blades.

**Engine**

Definitive information on engine maintenance is contained in the engine manual provided separately. Perform all maintenance procedures as recommended by the engine manual.

**! WARNING**



Shut off the engine before performing any maintenance. If the engine must be run after a maintenance operation make sure the area is well ventilated. The exhaust contains poisonous carbon monoxide gas! Exposure can cause loss of consciousness and may result in death.

**INITIAL MAINTENANCE**

Perform the following after initial purchase and operation of the MK-2000 Gas Saw.

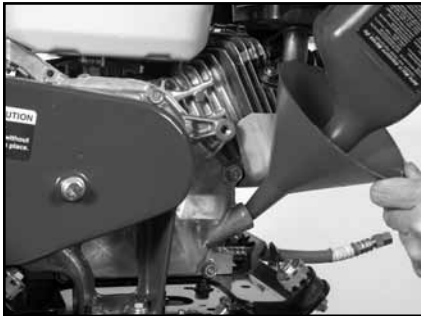

(A)

Change engine oil after first month or first 20 operating hours. Refer to Engine Manual.

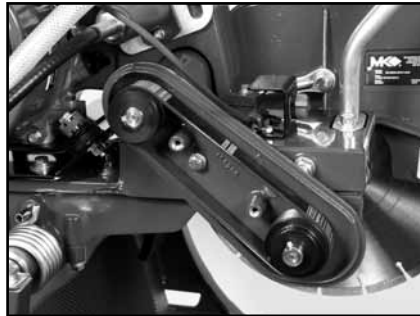

(B)

Check and adjust V-belt tension following first 48 hours of operation. See Micro V-belt Inspection.

**MAINTENANCE FOLLOWING USE**

To extend the life of the MK-2000 Gas Saw, the following procedure should be performed after each use. Lubricate all points listed below with light oil such as, 3 in 1, WD-40, etc.



(A)

Place Engine Switch in the OFF position.



(B)

Lubricate the Movable Cutting Table Roller Wheels.

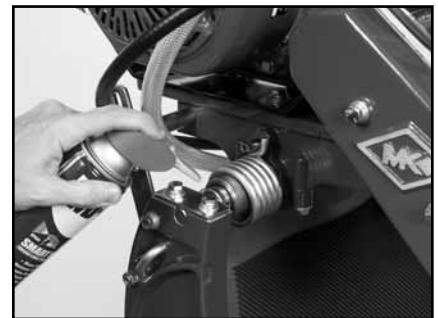

(C)

Lubricate Torsion Spring.



(D)

Lubricate Blade Guard Pivot.



(E)

Lubricate engine throttle linkage Points and Adjustment Bar. Refer to Engine Manual.

**MONTHLY MAINTENANCE**

The following should be performed monthly. Items should be lubricated as directed.



(A)  
Remove and clean Diamond  
Blade Outer Flange and  
Retaining Bolt.

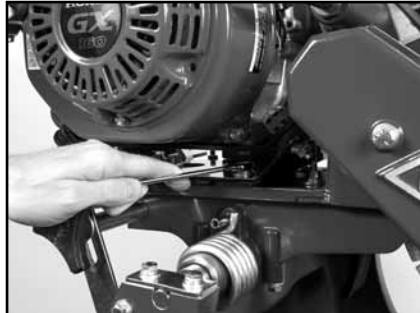

(B)  
Verify all engine mounting bolts  
are tight.



(C)  
Verify engine adjustment Straps  
are tight.

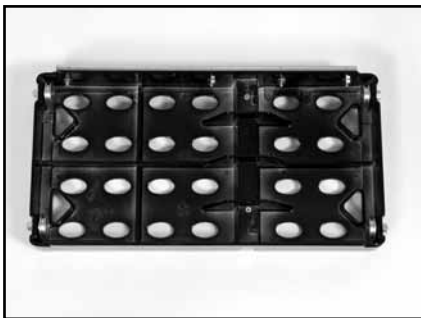

(D)  
Check movable Cutting Table  
Roller Wheels for wear.



(E)  
Clean engine air filter.  
Refer to Engine Manual.

**SIX (6) MONTH MAINTENANCE**

Perform the following maintenance every six months.



(A)  
Change engine oil. Refer to  
Engine Manual for all required  
engine maintenance.

**YEARLY MAINTENANCE**

Perform the following maintenance every year.

**Refer to Engine Manual for all required engine maintenance.**

1. Replace engine Air Filter. **Refer to Engine Manual.**
2. Replace Spark Plug. **Refer to Engine Manual.**
3. Check/Adjust Idle Speed Check/adjust Valve Clearance. **Refer to Engine Manual.**
4. Inspect Micro-V Belts.

**TWO-YEARLY MAINTENANCE**

1. Check Fuel Line. **Refer to Engine Manual.**

**BLADE DRESSING**

Like most cutting instruments, a diamond blade performs best when it is dressed. Over time and use, diamonds on the outer edge will become smoothed or “glazed” over. This will reduce grinding efficiency and may cause the blade to “wander” or bend giving the illusion of an alignment problem. When this occurs, the blade will need to be dressed. The diamond blade can be dressed using the MK Dressing Stick (part number 152792) and by following the steps below.

**NOTE:** Skip Steps D and E if cutting dry.



(A)

Setup MK-2000 Gas Saw for operation (See Setup, Startup, Adjustment Operation).



(B)

Set the adjustable Cutting Guide to cut 1/16-inch strips.

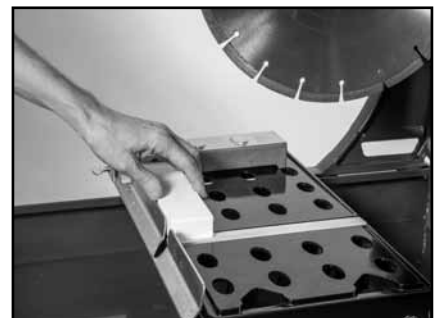

(C)

Position the Dressing Stick.



(D)

Open the Cooling Flow Control Valve and adjust flow. Verify cooling flow exists on both sides of the blade.



(E)

Move the Throttle Lever to adjust blade speed (faster blade speed for smoother cuts).



(F)

Cut the Dressing Stick 7 or 8 times to dress the Blade.

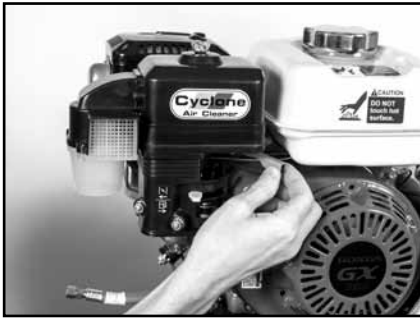

(H)

Move the Throttle Lever to lower blade speed. Refer to Engine Manual. Turn OFF saw.

**DIAMOND BLADE CHANGE-OUT**



(A)

Raise Cutting Head and remove Retaining Screw and Outer Flange.



(B)

Remove old Diamond Blade.

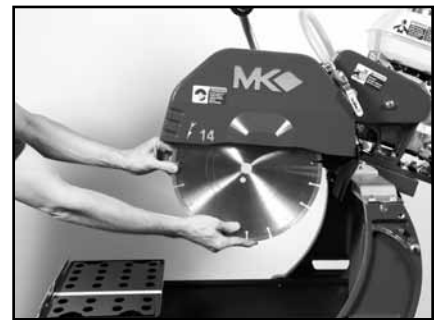

(C)

Install new Diamond Blade onto Blade Shaft.

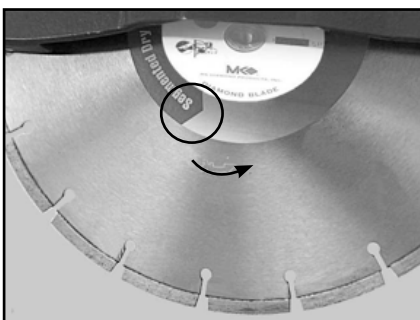

(D)

Verify Blade is seated on Blade Shaft in correct rotation direction.



(E)

Install Retaining Screw and Outer Flange then tighten.

**NOTE:** When installing the diamond blade retaining-bolt, ensure the threads of the bolt are aligned with the threads of the drive shaft so as not to “cross-thread” the bolt.



**PROTECTIVE WOODEN STRIP REPLACEMENT**

The protective wooden strip is to protect the Movable Cutting Table from damage during operation. Over time, the wooden strip will become grooved from use. A grooved wooden strip will not support masonry during cutting causing the blade to “break through” the piece instead of performing a smooth cut (MK Diamond Part No. – 156427).



(A)  
Remove the movable  
Cutting Table.

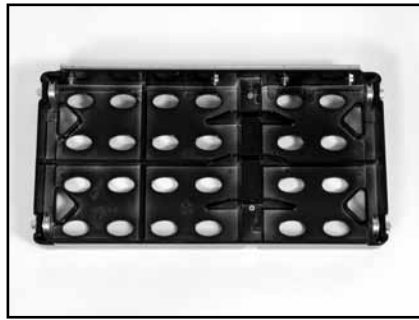

(B)  
Place movable Cutting Table on  
work bench with Roller Wheels up.



(C)  
Remove the two Protective  
Wooden Strip Retaining Screws.



(D)  
Replace worn Protective  
Wooden Strip.



(E)  
Tighten screw to secure new  
Wooden Strip.



(F)  
Install the movable Cutting Table.

**CHECK FUEL LEVEL**

Refer to Engine Manual for proper engine operation of your specific saw.

**WARNING**

1. Gasoline is highly flammable and explosive. You can be burned or seriously injured when handling fuel.
2. To fuel, stop engine if running and allow it to cool.
3. Refuel in a well-ventilated area.
4. Keep gasoline away from appliance pilot lights, barbecues, electric appliances, power tools, etc.
5. Wipe up spills immediately.

- NOTES:**
1. Fuel can damage paint and plastic. Be careful not to spill fuel when filling the fuel tank. Damage caused by spilled fuel IS NOT covered under the warranty.
  2. DO NOT use stale or contaminated gasoline or an oil/gasoline mixture.
  3. If using the Universal Stand with the MK-2000 Gas Saw, a ladder meeting OSHA specification is recommended.



(A)  
Remove Fuel Cap.

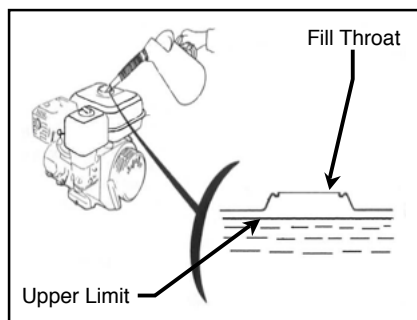

(B)  
Check Fuel Level. If level is 1/2 full or greater, go to Step D.



(C)  
Fill Fuel Tank until level is below throat.



(D)  
Install Fuel Cap. DO NOT over-tighten.

CHECKING OIL LEVEL

- NOTES:**
1. Refer to Engine Manual for proper engine operation of your specific saw.
  2. When installing the Oil Dipstick, ensure the threads are aligned with the threads of the Oil Reservoir so as not to “cross-thread.”

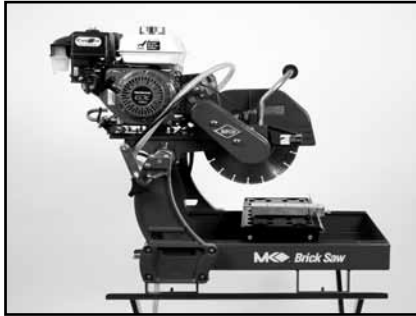

(A)  
Level Cutting Head.



(B)  
Remove Dipstick.

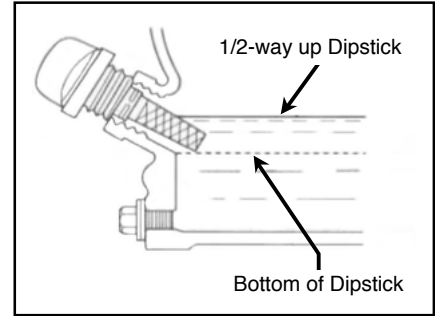

(C)  
Check Oil Level. If level is normal go to Step F.



(D)  
Fill Oil Reservoir.

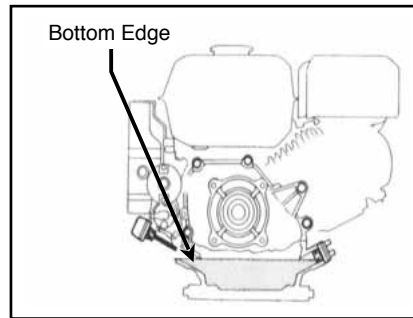

(E)  
Add Oil until level reaches the bottom edge of fill hole.

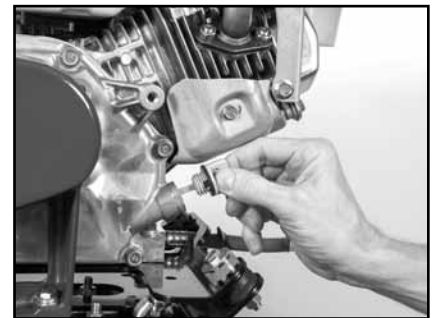

(F)  
Install the Dipstick.

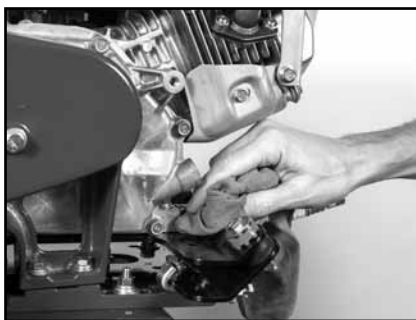

(G)  
Clean Up.

**CHANGING OIL**

**NOTE:** Refer to Engine Manual for proper engine operation of your specific engine.

Oil is a major factor affecting performance and service life. Use 4-stroke automotive detergent oil. SAE 10W-30 is recommended for general use. Other viscosity oil shown in the chart below may be used when the average temperature in your area is within the recommended range.

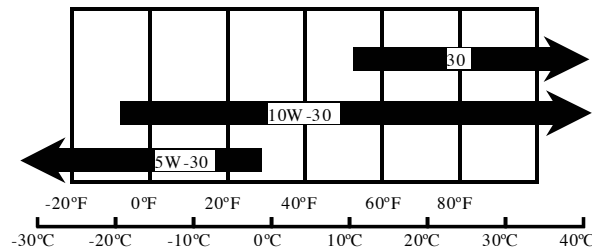

- NOTES:**
1. Drain used oil while the engine is warm.
  2. Conform to Federal, State and Local laws, codes and ordinances relative to environmental protection for oil disposal.

**ENGINE AIR FILTER INSPECTION CLEANING AND REPLACEMENT**

**NOTE:** Refer to Engine Manual for your specific engine.

**FUEL SEDIMENT CUP CLEANING**

Refer to Engine Manual for your specific saw.



- WARNING**
1. Gasoline is highly flammable and explosive. You can be burned or seriously injured when handling fuel.
  2. To fuel, stop engine if running and allow it to cool.
  3. Refuel in a well-ventilated area
  4. Keep gasoline away from appliance pilot lights, barbecues, electric appliances, power tools, etc.
  5. Wipe up spills immediately.

- NOTES:**
1. Conform to Federal, State and Local laws for the proper disposal of fuel.
  2. Fuel can damage paint and plastic. Be careful not to spill fuel when filling the fuel tank. Damage caused by spilled fuel IS NOT covered under the warranty.
  3. DO NOT use stale or contaminated gasoline or an oil/gasoline mixture.
  4. If using a stand with the MK-2000 Gas Saw, an OSHA approved ladder is recommended when fueling.
  5. When installing the Sediment Cup retaining bolt, ensure the threads of the bolt are aligned with the threads on the Fuel Valve so as not to “cross-thread the nut.”

**SPARK PLUG ADJUSTMENT AND REPLACEMENT**

Refer to Engine Manual for your specific saw.



**WARNING** DO NOT work around the engine while hot.

- NOTES:**
1. Recommended spark plugs are: NGK – BPR6ES or DENSO – W20EPR-U
  2. When installing the Spark Plug, ensure the threads of the are aligned with the threads in the engine so as not to “cross-thread” the plug.

**MICRO-V BELT INSPECTION, ADJUSTMENT AND REPLACEMENT**

The MK-2000 Gas Saw is designed with two power transmission Micro-V Belts. The two belts are a matched set and should be inspected, adjusted and/or replaced at the same time.

- NOTES:**
1. When new belts are installed, they should be inspected and re-tensioned after the first forty-eight (48) hours of operation.
  2. When performing any maintenance on the power transmission Micro-V Belts, always start with the belt on the Blade Guard side.

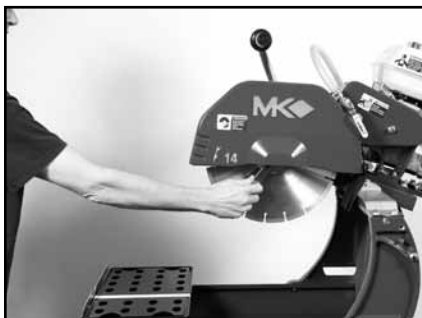
**BLADE SIDE MICRO-V BELT**

(A)  
Remove Diamond Blade (See Diamond Blade Change-out).



(B)  
Identify the Water Pump Pivot Plate.



(C)  
Loosen Water Pump Drive end Pivot Plate front and rear Retaining Bolts.



(D)  
Pivot front of Water Pump drive end Pivot Plate up and tighten the Retaining Bolts.



(E)  
Disconnect the Blade Guard Adjustment Bar.

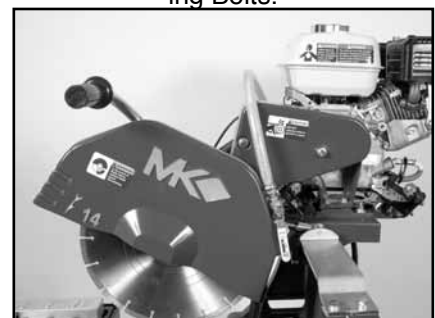

(F)  
Pivot Blade Guard to expose Belt Guard Retaining Bolts.

**NOTE:** Step G may require the pump discharge line to be repositioned.

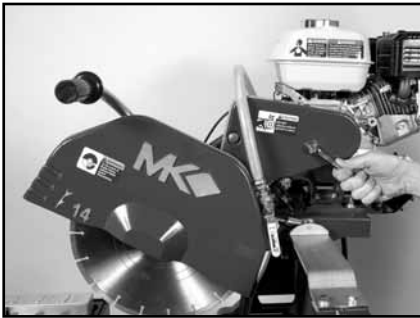

(G)  
Remove the Belt Guard Retaining Bolts.

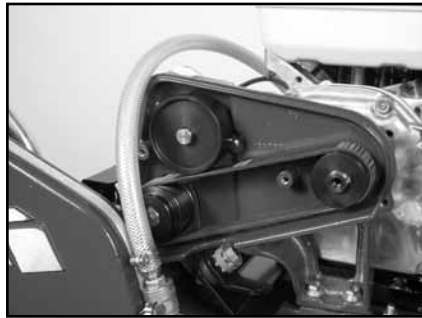

(H)  
Inspect the Micro-V Bolt for cracks, fraying, separation and tears. Go to step J if replacement require.



(I)  
Check Belt for proper tension. If tension correct, go to Step U (proper tension 1/8-inch).

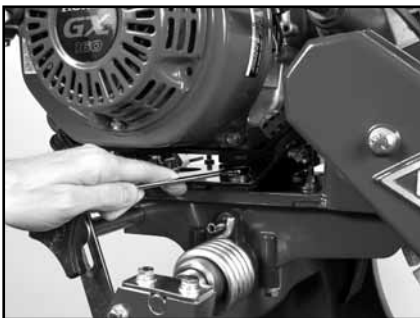

(J)  
Loosen engine mounting plate. If re-tensioning, go to step S.



(K)  
Loosen Ending Adjustment Strap Lock-nut then loosen the Engine Adjustment Strap.

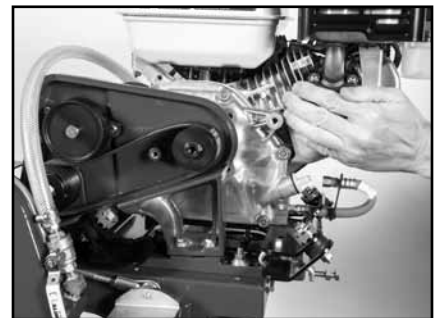

(L)  
Push the Engine Mounting Plate toward the front of the unit to loosen the Micro-V Belt.

**NOTE:** DO NOT use a screwdriver when installing new belts.



(M)  
Remove the Micro-V Belt.



(N)  
Install the new Micro-V Belt (MK Diamond Part No. 156294).



(O)  
Verify the Micro-V Belt is seated in the grooves of both pulleys.



(P)  
Verify the Engine Adjustment Strap Lock-Nut is loose then tighten the Adjustment Strap.



(Q)  
Check Micro-V Belt tension (proper tension 1/8-inch).



(R)  
Continue adjusting Micro-V Belt until tension is correct then tighten the Engine Adjustment Strap Lock-Nut.



(S)  
Tighten the Strap Lock-Nut.

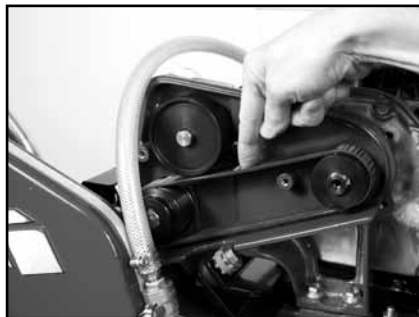

(T)  
Check Micro-V Belt tension (proper tension 1/8-inch).

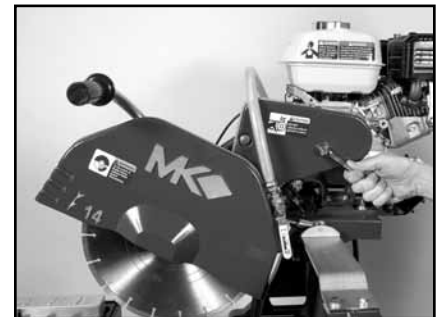

(U)  
Install the Belt Guard.



(V)  
Locate Water Pump Pivot Plate loosen retaining bolts.



(W)  
Move Water Pump Pivot Plate down and retighten retaining bolts.



(X)  
Install the Blade Guard Adjustment Bar.



(Y)  
Install the Diamond Blade.

**ENGINE SIDE MICRO-V BELT**

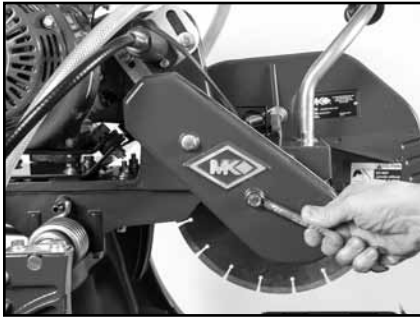

(A)  
Remove the Belt Guard Retaining Bolts.

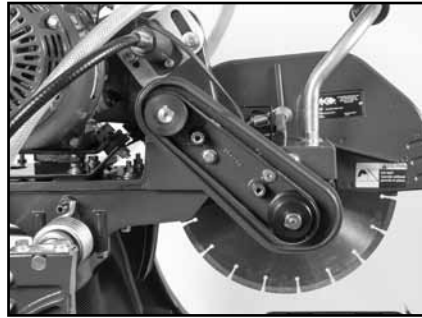

(B)  
Inspect the Micro-V Belt for cracks, fraying, separation and wear. Go to Step D if replacement required.

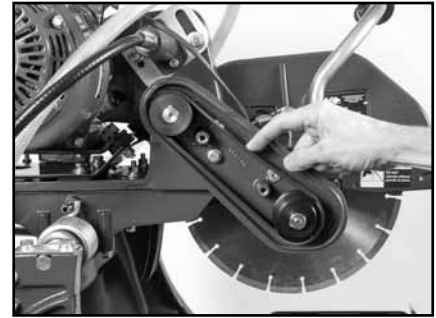

(C)  
Check Micro-V Belt proper tension if tension correct, go to Step O (proper tension 1/8-inch).



(D)  
Loosen engine mounting plate. If re-tensioning, go to Step J. 5 bolts, 4 under motor, 1 to left of power switch.



(E)  
Loosen Engine Adjustment Strap Lock-Nut then loosen the Engine Adjustment Strap.

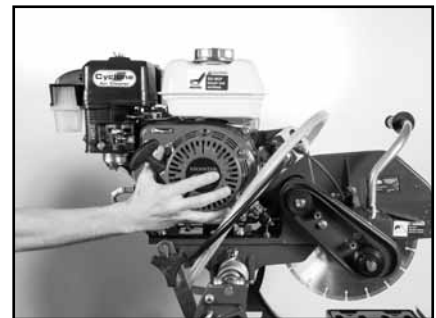

(F)  
Push the Engine Mounting Plate toward the front of the unit to loosen the Micro-V Belt.

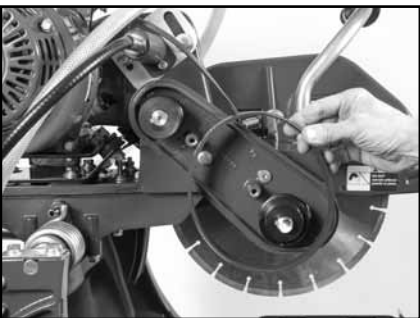

(G)  
Remove the Micro-V Belt.

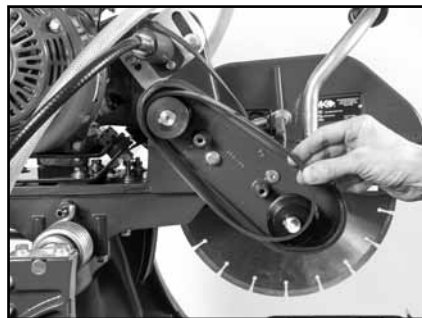

(H)  
Install the new Micro-V Belt (MK Diamond Part No. 156294).

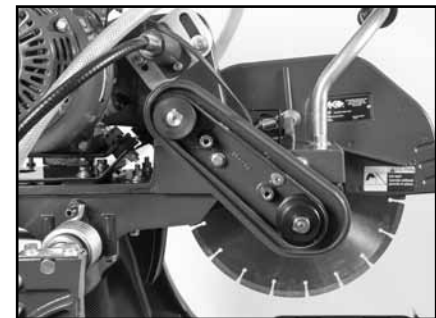

(I)  
Verify the Micro-V Belt is seated in the grooves of both pulleys.





(J)  
Verify the Engine Adjustment Strap Lock-Nut is loose then tighten the Adjustment Strap.

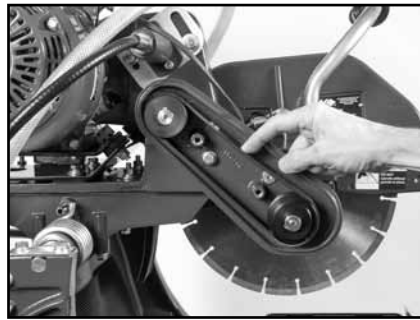

(K)  
Check Micro-V Belt tension (proper tension 1/8-inch).



(L)  
Continue adjusting Micro-V Belt until tension is correct. Then tighten the Engine Adjustment Strap Lock-Nut.

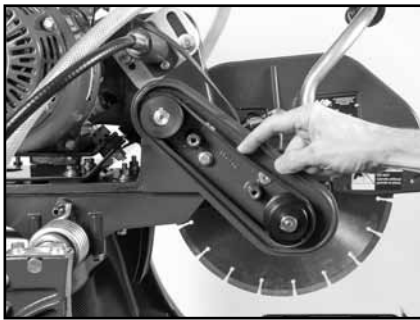

(M)  
Check Micro-V Belt tension (proper tension 1/8-inch).



(N)  
Tighten Base Plate.



(O)  
Install the Belt Guard.

**BLADE WILL NOT CUT PROPERLY**

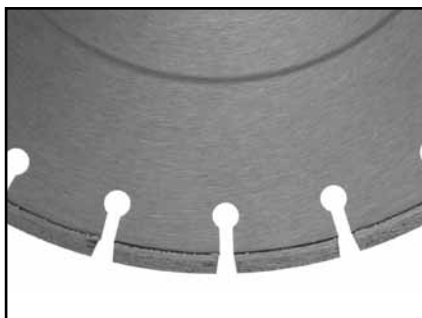

(A)  
Check for Smoothness or "Glazing".

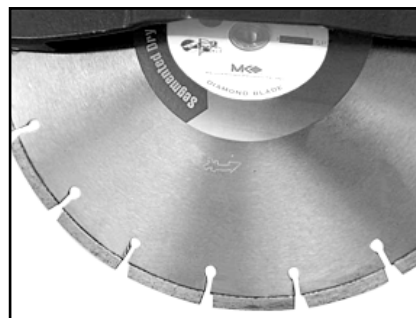

(B)  
Check for Proper Rotation.

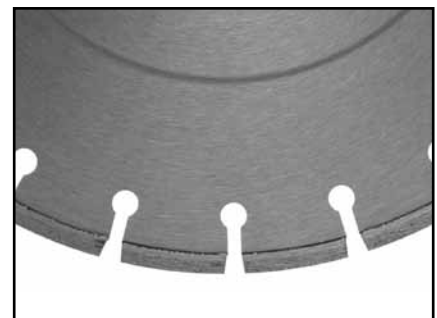

(C)  
Ensure Blade Core bent.



(D)

Verify blade correct for material being used.

**MOVABLE CUTTING TABLE DOES NOT MOVE CORRECTLY**

---



(A)

Check that the Guide Rails are clean and clean if dirty.



(B)

Check the Movable Cutting Table Roller Wheels and replace if necessary.

**COOLING FLOW**

---



(A)

Verify Water Pump drive end is in the operating position - if in operating position go to Step B.

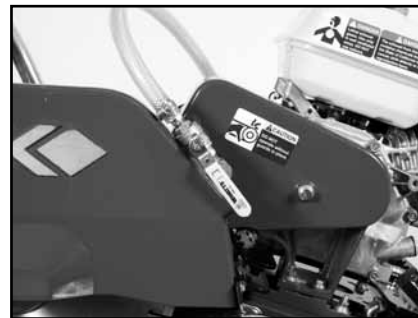

(B)

Check Cooling Flow Control Valve is open.



(C)

Loosen hose clamp and remove transfer tube from control valve on Blade Guard.



(D)

Place Water Pump and Transfer Tube in clean water source. Start saw and check for flow (if no flow go to Step G).



(E)

Verify Cooling Valve operation by removing the valve from the Blade Guard.



(F)

Attach the Cooling Valve to the Transfer Tube to verify flow - if no flow, replace valve.

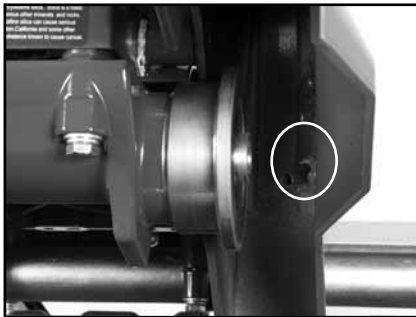

(G)

Check Rod Cooling Channels and recheck flow. If no flow go to Step I.

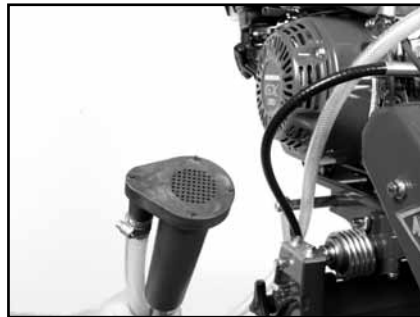

(H)

Verify Water Pump suction is clean and pump impeller is turning - if not turning, replace.

**NOTE:** “Rodding” cooling channels is performed by removing the flow control valve and then inserting a small wire rod through the cooling channel inlet, on the top of the Blade Guard and directing the rod out through each of the diamond blade cooling flow outlet ports, located on the underside of the Blade Guard. The cooling channels should be “rodded” until each of the outlet ports are open and free of foreign debris.

## BLADE STOPS TURNING

---



(A)

Check if engine is operating, if not restart (See Setup, Startup, Adjustment, Operation and Shutdown).



(B)

Check Micro-V Belts (See Micro-V Belt Inspection, Adjustment and Replacement).

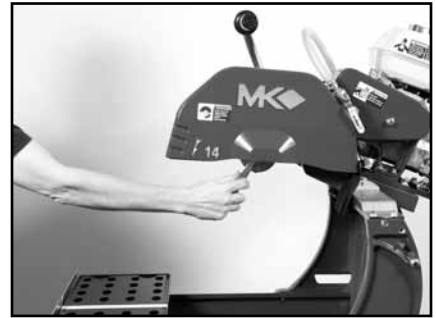

(C)

Verify Blade Retaining Screw is tight. (See Blade Installation).

## ENGINE STOPS

---

Refer to Engine Manual for details.



MK-2000 Saw Assembly Part # 155961

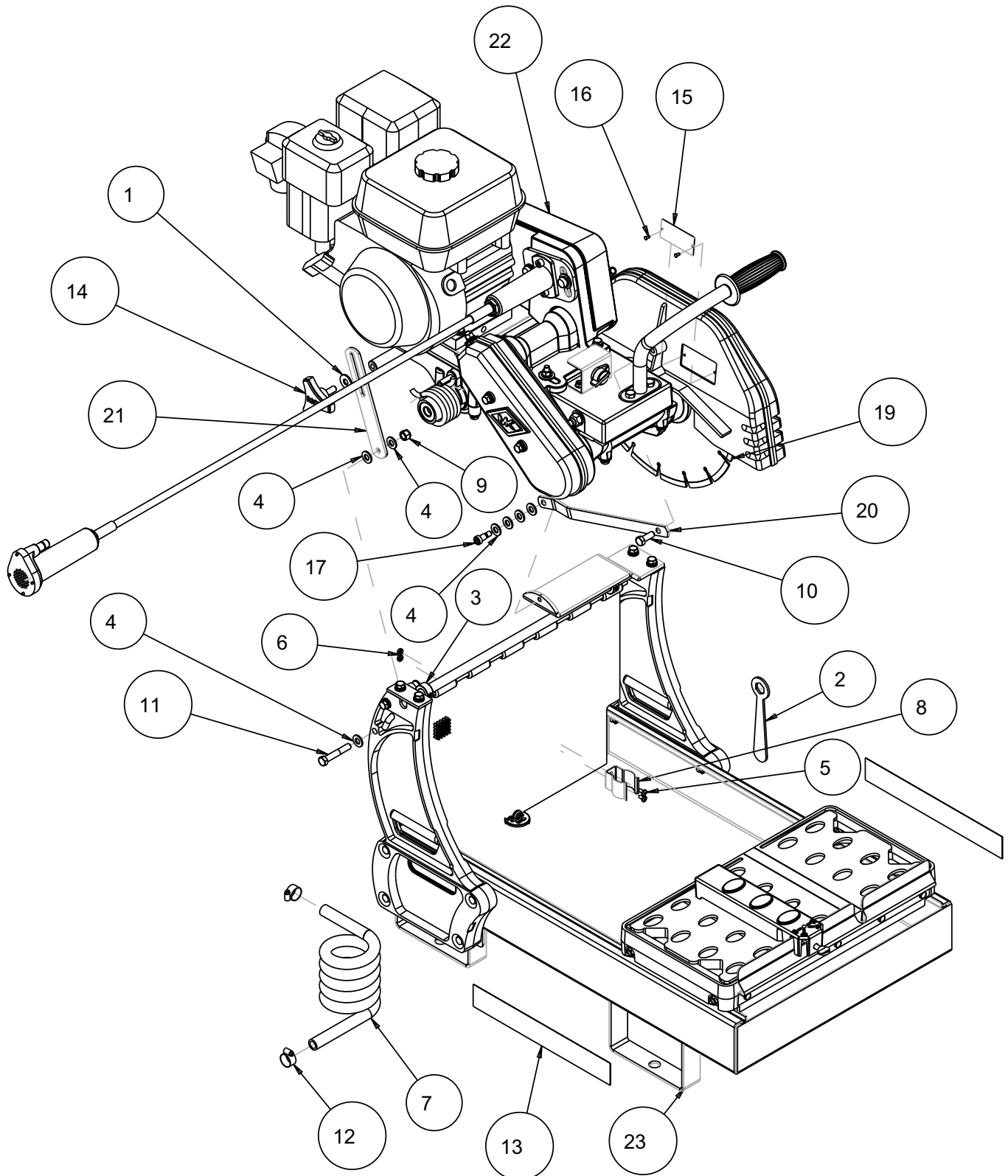

## MK-2000 Saw Assembly Part # 155961

ITEM	DESCRIPTION	PART #	QTY.
1	WASHER, FLAT, USS, 3/8	101360	1
2	WRENCH, 3/4 BOX END	134056	1
3	COLLAR, 1.13 ODX 625ID .5 WIDE	140012	2
4	WASHER, FLAT, SAE, 3/8	150923	7
5	SCREW, PAN HD, #10-24X3/8	151097	2
6	NUT, HEX, 10-24	151749	2
7	HOSE, VINYL, 1/4X3/8 (32.0')	152410	1
8	CLAMP, SPRING	152453	1
9	SCREW, HEX HD CAP, 3/8-16	152505	1
10	SCREW, HEX HD 3/8-16 X 1	152507	1
11	SCREW, 3/8-16 X 2-1/4 HEX HEAD	153529	1
12	CLAMP, HOSE, 7/8	154173	2
13	LABEL, MK BRICKSAW 12-1/2X1-3/4	155230	2
14	KNOB, TRI PLASTIC, 1"	156770-01	1
15	TAG, SERIAL NUMBER, BLANK	157500-RW	1
16	SCREW, DRIVE, RND HD, #7X5/16	157849	2
17	SCREW, SHOULDER 3/8 X 1/2	160078	1
18	MASONRY LABEL SHEET (NOT SHOWN)	166011	1
19	BLADE, CG, 14X125X1 10MM	166308	1
20	BAR, BLADE GUARD ADJ.	166602	1
21	BRACKET, HEIGHT ADJUSTMENT	166868	1
22	ASSY, CUTTING HEAD, 5.5 HP HONDA, 14"	170817	1
23	ASSY, FRAME, 2000	170818	1

MK-2000 Cutting Head, 5.5 HP Honda Part # 170817

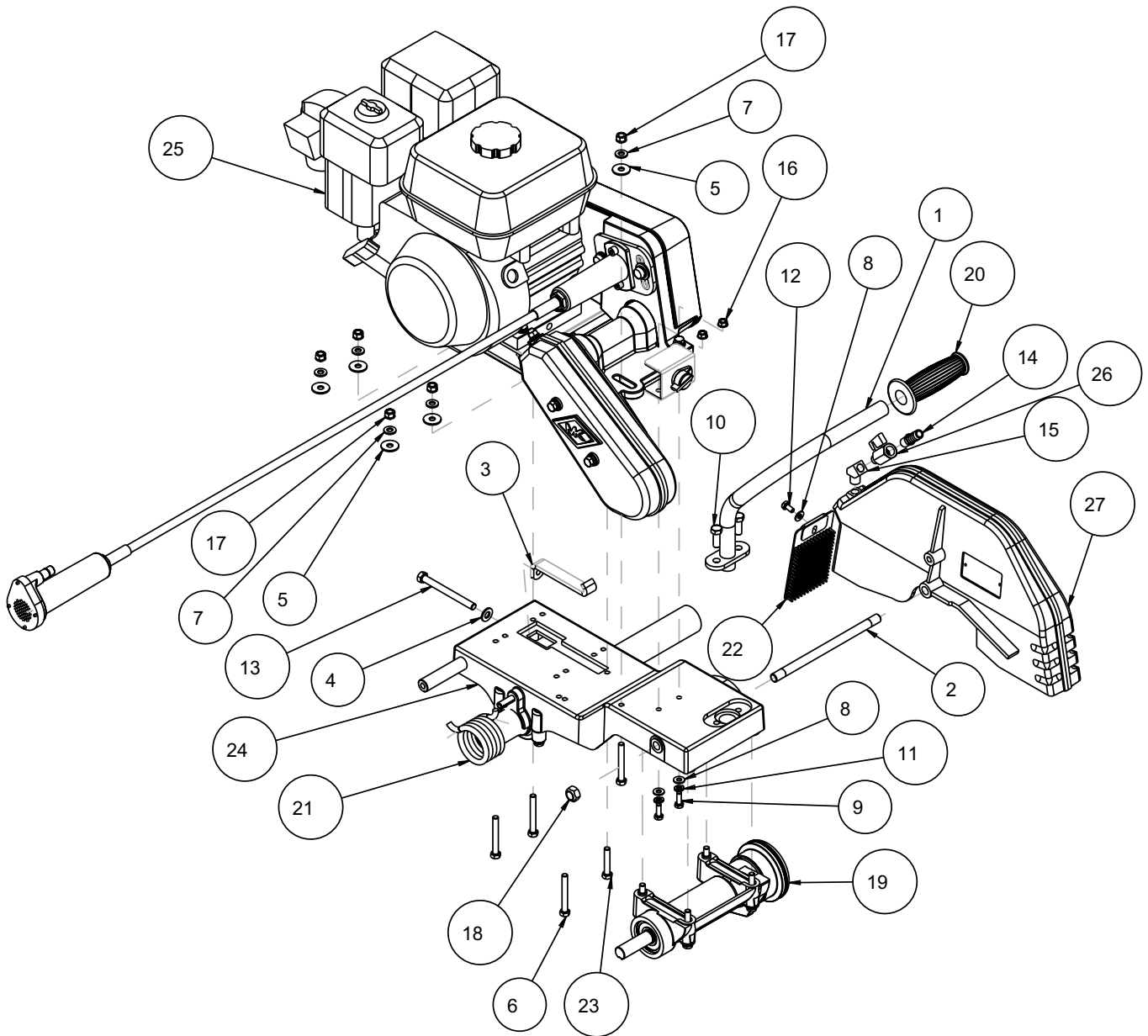



## MK-2000 Cutting Head, 5.5 HP Honda Part # 170817

ITEM	DESCRIPTION	PART #	QTY.
1	HANDLE, BRICKSAW	139931	1
2	STUD, BLD GUARD	150581	1
3	STRAP, MOTOR ADJ	150584	1
4	WASH, FLAT, SAE, 3/8	150923	1
5	WASHER, FENDER, 5/16 X 1.0	151053	5
6	BOLT, HEX HD TAP, 5/16-18X2-1/2	151748	4
7	WASHER, FLAT, SAE, 5/16	151754	5
8	WASHER, FLAT, SAE, 1/4	151915	3
9	SCREW, HEX HD, 1/4-20X3/4	152370	2
10	SCREW, HEX HD CAP, 3/8-16 X 1	152507	2
11	WASHER, LOCK, SPLIT, 1/4	152591	2
12	SCREW, 1/4-20 X 1/2 HEX HEAD	152608	1
13	BOLT, 3/8-16 X 4 HEX HEAD TAP	152678	1
14	FITTING, 1/4 MNPT X 1/2 BARB	152704	1
15	ELBOW, 1/4 NPT X 45 STREET	153869	1
16	NUT, HEX, TW, 1/4-20	153941	2
17	NUT, HEX, TW, 5/16-18	153942	5
18	NUT, 1/2-13 HEX	153943	1
19	ASSY, ARBOR, MK-2000	154636	1
20	GRIP, HANDLE 7/8 ID	158608	1
21	SPRING, TORSION, 50 DEG	160071	1
22	GUARD, SPLASH	160310	1
23	SCREW, 5/16-18 X 1-3/4 HEX HEAD MACHINE	160948	1
24	ASSY, MOTOR MOUNT, MK-200	160966	1
25	ASSY, ENGINE, 2000G	170819	1
26	VALVE, BALL 1/4"M X 1/4"F	231248	1
27	CASTING, 2000, BLD GRD-COMP	150579G	1

Assy. Frame Part # 170818

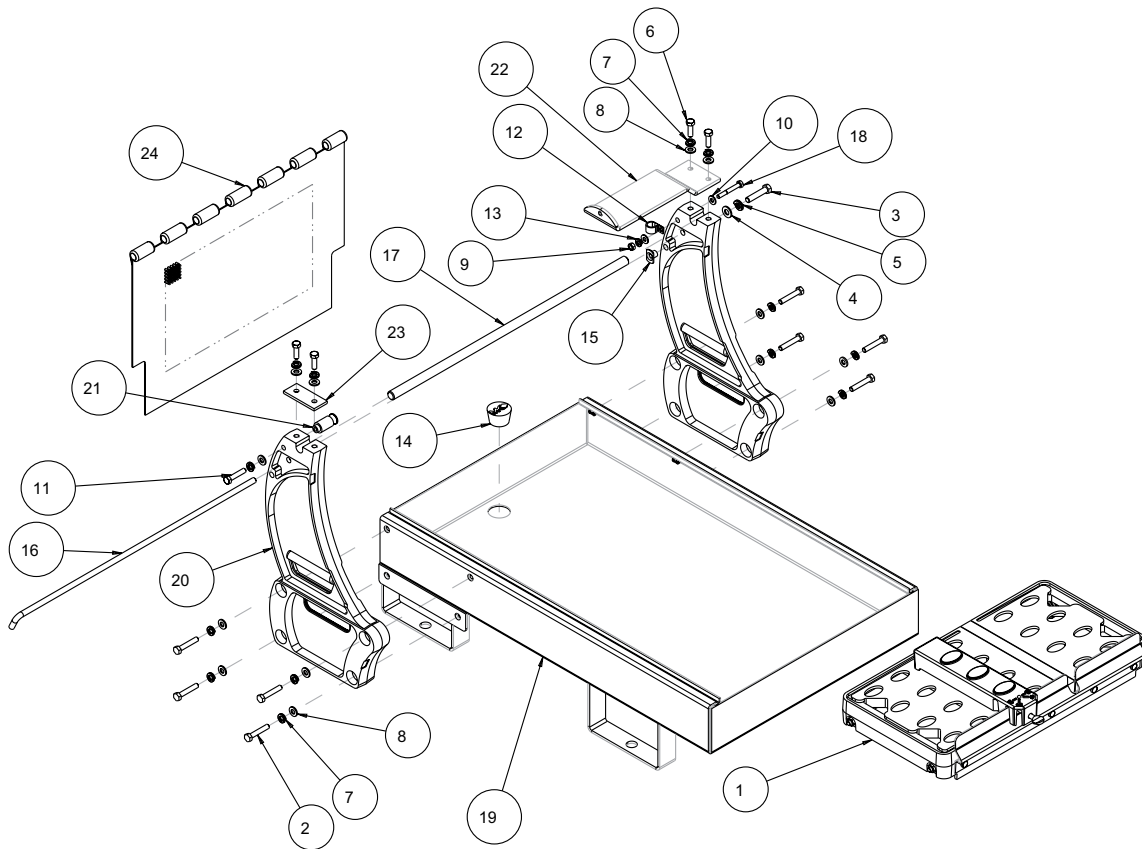

ITEM	DESCRIPTION	PART #	QTY.
1	ASSY, CONVYR CART	133082	1
2	SCREW, HEX HD, CAP, 5/16-18X1-3/4	150919	8
3	SCREW, HEX HD, 3/8-16 X 1-3/4	150920	1
4	WASHER, FLAT, SAE, 3/8	150923	1
5	WASHER, LOCK, SPLIT, 3/8	150925	1
6	SCREW, HEX HD, 5/16-18X1	151743	4
7	WASHER, LOCK, SPLIT, 5/16	151747	13
8	WASHER, FLAT, SAE, 5/16	151754	13
9	NUT, HEX, 1/4-20	151893	1
10	WASHER, FLAT, SAE, 1/4	151915	2
11	SCREW, 5/16-18 X 1-1/2 HEX HEAD MACHINE	152467	1
12	CLAMP, 1/2 CUSHION LOOP	152471	1
13	WASHER, LOCK, SPLIT, 1/4	152591	1
14	PLUG, RBBR DRAIN W/O HOLE	153439	1
15	NUT, WELD, SLAB. 3/8-16	153945	1
16	ROD, SPLASH CURTAIN	153956	1
17	SHAFT, PIVOT, 5/8	154147	1
18	SCREW, HEX HD 1/4-20 X 2	158282	1
19	WELDMENT, BASE FRAME	158845	1
20	POST (COMP)	158846	2
21	STUD, SPRING RETAINING	160066	1
22	BRACKET, STAY LEVEL CLIPPER PAV	160068	1
23	BRACKET, PIVOT SHAFT	160070	1
24	CURTAIN, SPLASH, MK-2000	160972	1

Assy. Engine MK-2000G Part # 170819

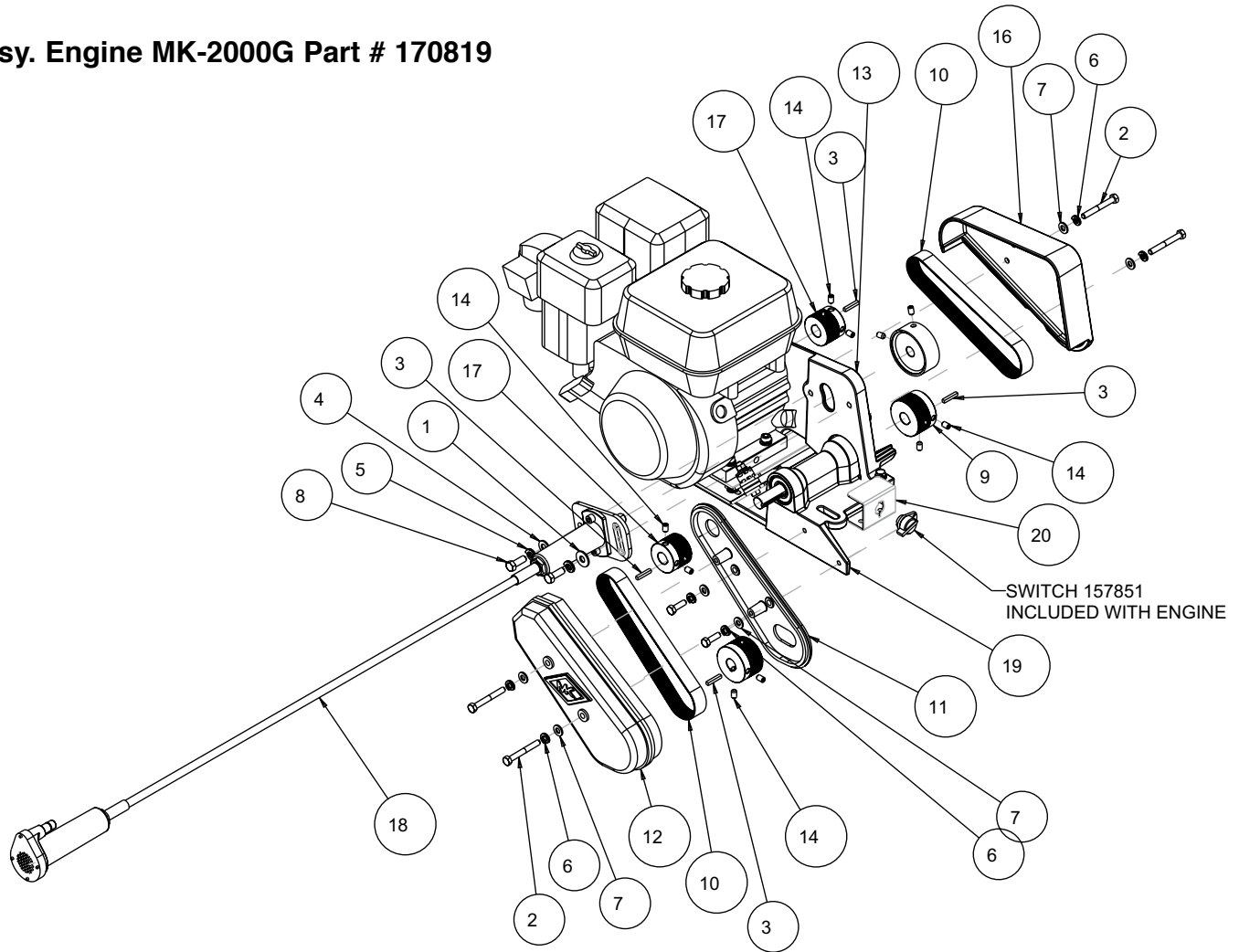

ITEM	DESCRIPTION	PART #	QTY.
1	WASHER, FLAT, USS, 3/8	101360	1
2	SCREW, HEX HD, 5/16-18X2-1/2	101675	4
3	KEY, 3/16 SQ X 1-1/8	150344	4
4	WASHER, FLAT, SAE, 3/8	150923	1
5	WASHER, LOCK, SPLIT, 3/8	150925	2
6	WASHER, LOCK, SPLIT, 5/16	151747	21
7	WASHER, FLAT, SAE, 5/16	151754	17
8	SCREW, HEX HD CAP, 3/8-16 X 1	152507	2
9	PULLEY, 10J23 X 3/4 BORE	156292	2
10	BELT, 10J218	156294	2
11	BELT GUARD, ENGINE, INNER ARBOR (MACH)	156669	1
12	CASTING, BELT GUARD, OUTER, 2000G-RAW	156670	1
13	BELT GUARD, ENGINE, INNER (COMP)	156671	1
14	SCREW, 5/16-18 X 3/8 SOCKET HEAD SET	157084	8
15	WIRE HARNESS, BRICK SAW GAS	157414	1
16	GUARD, ENGINE, OUTER (COMP)	160063	1
17	PULLEY, 10J19 X .75 BORE	160950	2
18	ASSY, PUMP, WATER, 2005/6 GAS	161126	1
19	ASSY, ENGINE MOUNT, 2000G	170820	1
20	BRACKET, SWITCH (GAS)	231313	1

Assy. Engine MK-2000G Part # 170819

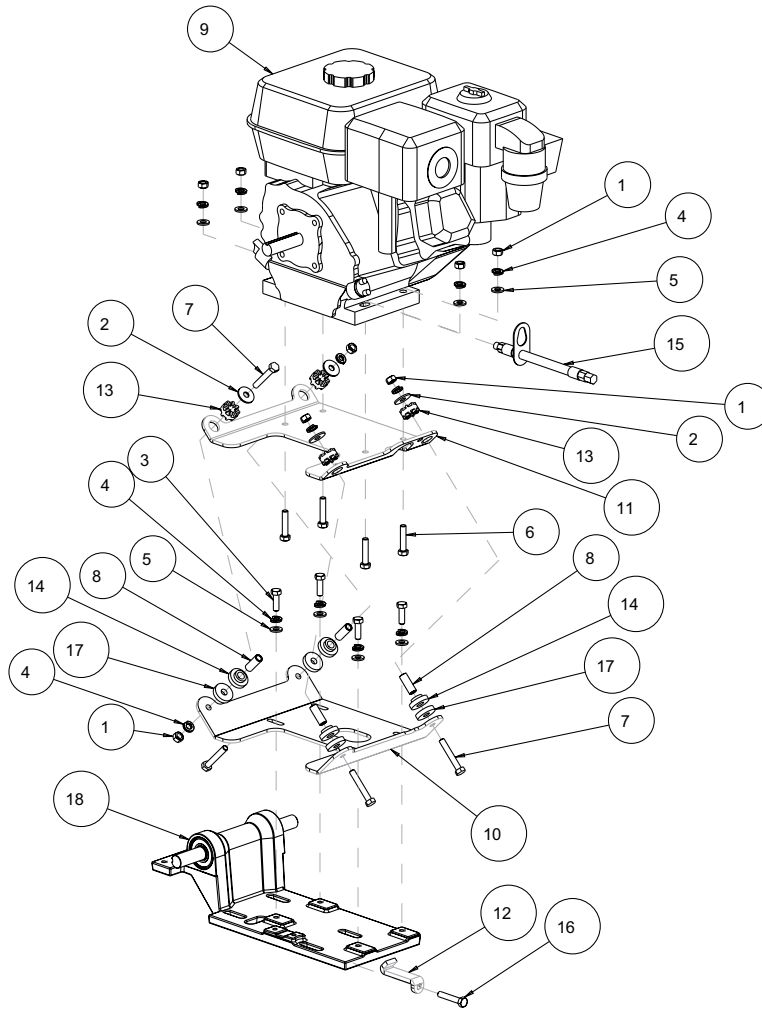

ITEM	DESCRIPTION	PART #	QTY.
1	NUT, HEX, 5/16-18	101196	8
2	WASHER, FENDER, 5/16 X 1.0	151053	4
3	SCREW, HEX HD, 5/16-18X1	151743	4
4	WASHER, LOCK, SPLIT, 5/16	151747	12
5	WASHER, FLAT, SAE, 5/16	151754	8
6	SCREW, 5/16-18 X 1-1/2 HEX HEAD MACHINE	152467	4
7	SCREW, 5/16-18 X 2 HEX HEAD	155494	4
8	STAND OFF, SHOCK MOUNT	156104	4
9	ENGING, HONDA GX160 W/CYC	156282	1
10	PLATE, ENGINE MNT LOWER	156296	1
11	PLATE, ENGINE MNT UPPER	156297	1
12	STRAP, BELT TENSION MK-2005	156955	1
13	PLATE, ENGINE MNT UPPER	156961	4
14	MOUNT, SHOCK LOWER	156962	4
15	ASSY, OIL DRAIN, 10MM	157577-01	1
16	SCREW, 5/16-18 X 1-3/4 HEX HEAD MACHINE	160948	1
17	MOUNT, SHOCK, WASHER	164244	4
18	ASSY, ENGINE MOUNT, 2000G	170820	1

**Motor Mount Part # 170820**

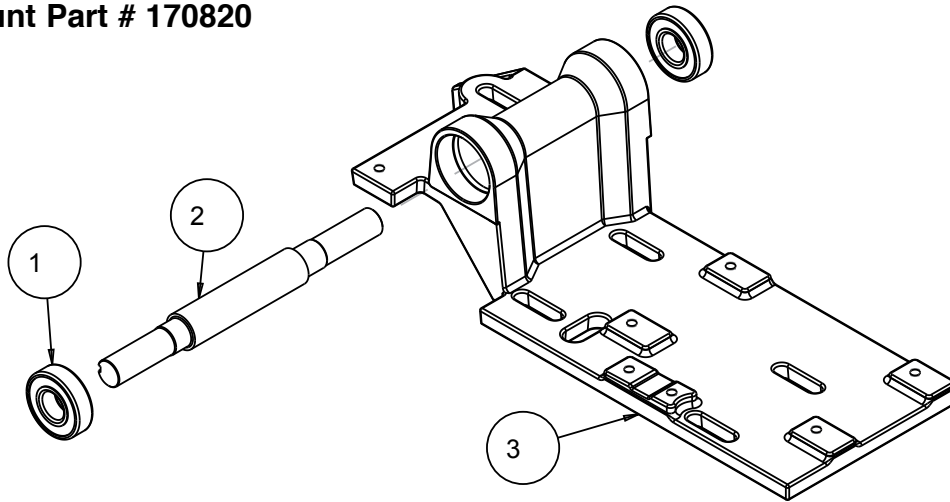

ITEM	DESCRIPTION	PART #	QTY.
1	BEARING, BLAD SHFT MK2000	139956	2
2	SHAFT, JACK	156295	1
3	MOUNT, ENGINE (COMP)	156673	1

**Motor Mount Part # 160966**

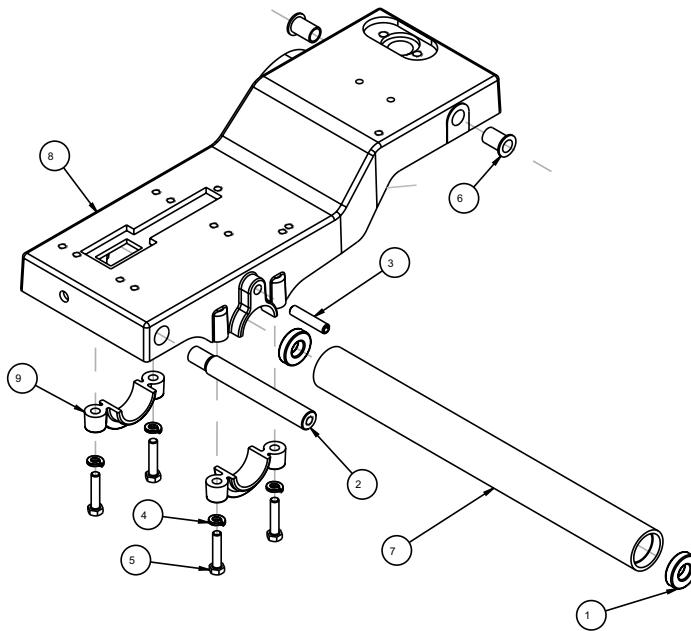

ITEM	DESCRIPTION	PART #	QTY.
1	BEARING, CUTTING HD PIV	140004	2
2	BAR, ADJUSTMENT	150585	1
3	PIN, SLOTTED SPRING, 3/8 X 1-3/4	151358	1
4	WASHER, LOCK, SPLIT, 5/16	151747	4
5	SCREW, 5/16-18 X 1-1/2 HEX HEAD MACHINE	152467	4
6	BUSHING, FLANGE, 1/2X5/8X1	156441	2
7	HOUSING, PIVOT SHAFT	157979	1
8	HEAD, CUTTING (COMP)	160346	1
9	CLAMP, CUTTING HEAD (COMP)	160397	2

Assy, Pump, Water, 2005/6 Part # 161126

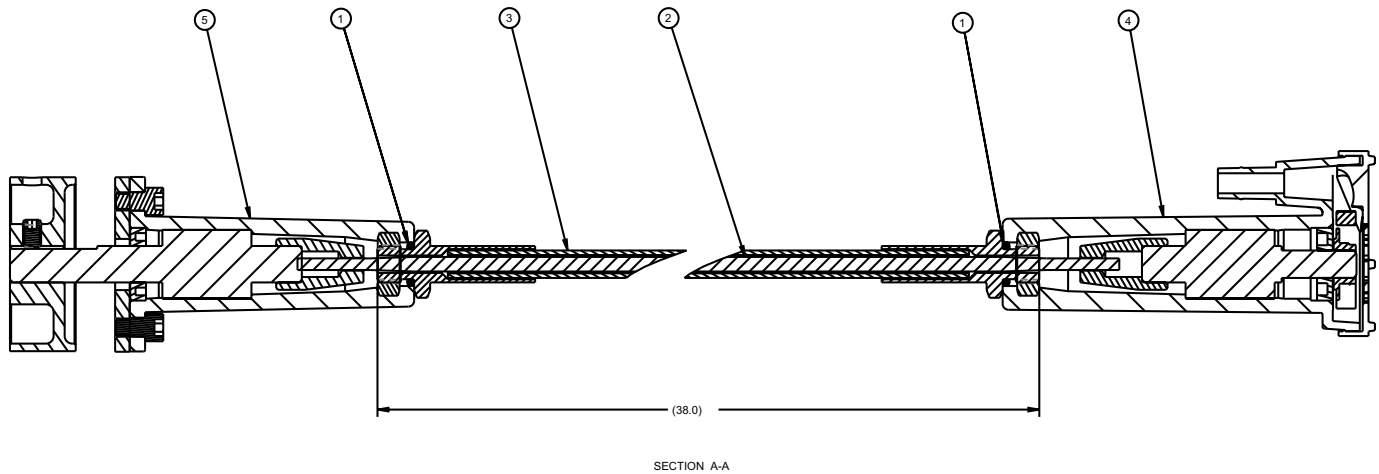

ITEM	DESCRIPTION	PART #	QTY.
1	PUMP MOUNTING PLATE	156108	1
2	SCREW, 5/16-18X1/2 SOCKET HEAD CAP	156139	2
3	SCREW, 5/16-18 X 3/8 SOCKET HEAD SET	157084	2
4	O-RING	160175	2
5	SHAFT, FLEX 40 3/4	160177	1
6	ASSY, HOUSING, 38" FLEX SHAFT	160178	1
7	ASSY, PUMP, CENTRIFUGAL WATER	160185	1
8	ASSY, DRIVER	160186	1
9	PULLEY, FLAT 3.0 DIA X 1.0 X 5/8	160431	1

Assy. Arbor Part # 154636

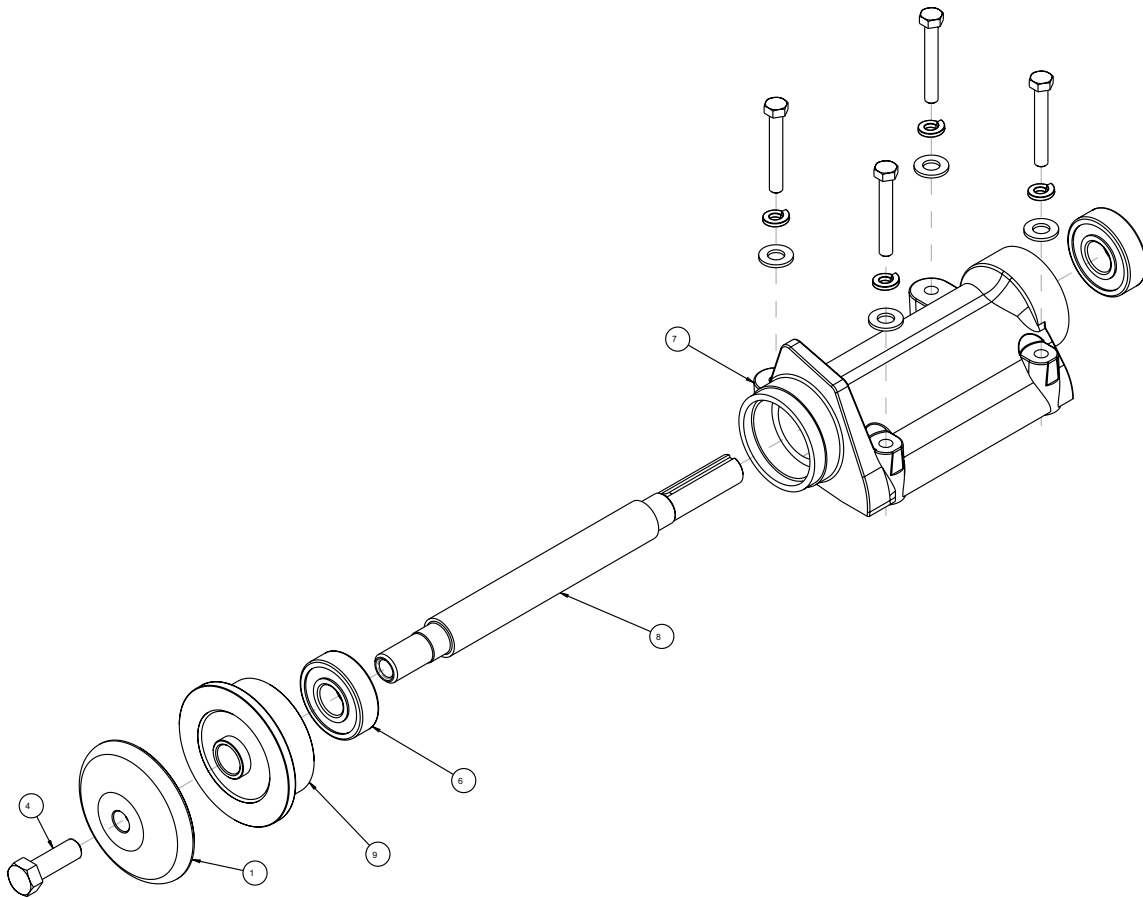

ITEM	DESCRIPTION	PART #	QTY.
1	FLANGE, OUTER	132290	1
2	WASHER, FLAT, SAE, 3/8	150923	4
3	WASHER, LOCK, SPLIT, 5/16	151747	4
4	SCREW, HEX HD 1/2-20X1-1/4	152122	1
5	SCREW, HEX, 5/16-18 X 2-1/4	153951	4
6	BEARING, ARBOR HOUSING	154594	2
7	CASTING, 2000/5000 ARBOR - COMP	154637	1
8	SHAFT, BLADE	154639	1
9	FLANGE, ARBOR, INNER	154640	1

Assy Table Part # 133082

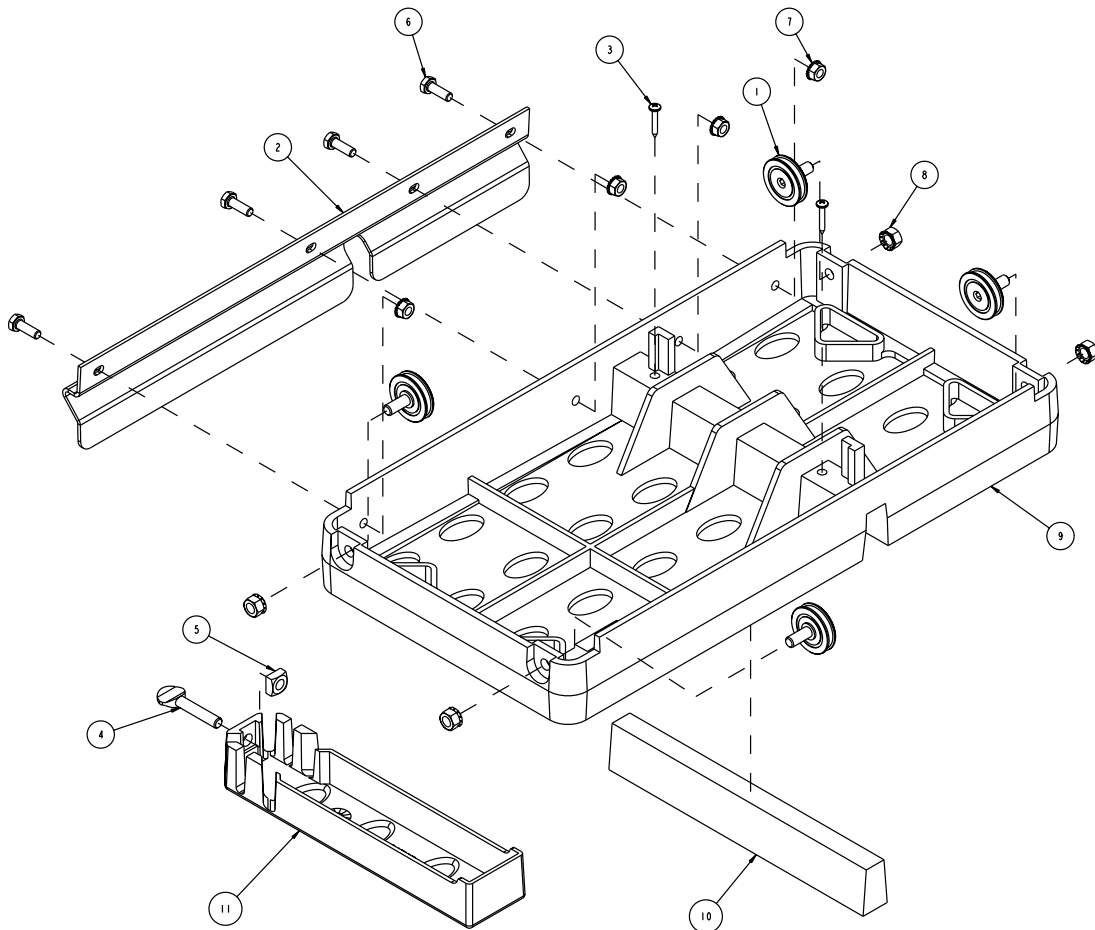

ITEM	DESCRIPTION	PART #	QTY.
1	WHEEL, CONVEYOR CART	133090	4
2	STOP, BACK-CONVEYOR CART	134387	1
3	SCREW, PAN HD PHIL #8 X 1	151047	2
4	SCREW, THUMB 5/16-18 X 1- 1/2	151155	1
5	NUT, SQUARE 5/16 - 18	151156	1
6	SCREW, 1/4 -20 X 3/4 HEX HEAD MACHINE	152370	4
7	NUT, HEX W/WSHR, 1/4 - 20	153941	4
8	NUT, HEX W/WSHR 5/16 - 18	153942	4
9	TABLE, D.C., COMP	158144	1
10	WOOD STRIP, TABLE INSERT	158283	1
11	CASTING, SQUARING ARM - COMP	231276	1



ITEM	NUMBER	DESCRIPTION	
1.	152792	Dressing Stick	
2.	153331	Folding Saw Stand	
3.	160617	MK-565SKMR Supreme Masonry Diamond Blade	

**ORDERING INFORMATION**

---

You may order MK Diamond products through your local MK Diamond distributor or, you may order direct from MK Diamond.

When ordering direct from MK Diamond, please have the following information ready before calling:

- The Model Number of the saw
- The Serial Number of the saw
- Where the saw was purchased and when
- The Part Number for the part(s) being ordered
- The Part Description for the part(s) being ordered

**NOTE:** There is a \$25.00 minimum order when ordering direct from MK Diamond. A \$6.00 charge will be added to orders having a net billing value under \$50.00. All purchases must be made using VISA, MasterCard or American Express.

All parts may be ordered by calling toll free to – 800 421-5830 or 310 539-5221 and asking for Customer Service. For technical questions, call – 800 474-5594.

**RETURN MATERIALS POLICY**

---

To expedite the service relative to the return of a product purchased through MK Diamond, please observe the following:

**NOTE:** When returning all items, they must have been purchased within the previous twelve (12) months.

- Have the Model Number of the saw
- Have the Serial Number of the saw
- Have the location of where the saw was purchased
- Have the date when the saw was purchased
- Contact Customer Service for approval to return the item(s)
- Obtain a Returned Goods Number (RGA) authorizing the return
- Follow the packaging instructions in the following section
- Ensure your item(s) are prepaid to the destination

For returned items, call toll free to – 800 421-5830 or 310 539-5221 and ask for Customer Service. For technical questions, call – 800 474-5594 or 310 257-2845.

**PACKAGING INSTRUCTIONS**

---

- Remove the Cutting Head and Support Angle Assembly
- Dry the saw before shipping
- When packing, include the following: Saw, Diamond Blade, Blade Guard and Support Angle Assembly and Adjustable Cutting Guide (Other Accessories are not required)
- Package the unit in its original container or one of comparable size (do not ship the unit partially exposed)
- Ensure all parts are secured in the packaging to prevent moving

**AUTHORIZED SERVICE CENTERS**

---

For quicker repair time, you may contact MK Diamond Customer Service, toll free, at 800 421-5830 or 310 539-5221 for the Authorized Service Center closest to you or visit our web site at [www.mkdiamond.com](http://www.mkdiamond.com). For technical questions, call – 800 474-5594.

**CONTACT**

---

Please contact MK Diamond Products, Inc. Customer Service Department with any questions you might have regarding distributors, parts or service.

Telephone: **(800) 421-5830**

Fax: **(310) 539-5158**

E-mail: **Customer\_Service@MKDiamond.com**

Customer Service Hours: **Monday through Friday, 6AM-4PM PST**

**MK Diamond Products, Inc.**

**1315 Storm Parkway**

**Torrance, CA 90501**

**MK DIAMOND PRODUCTS, INC. LIMITED WARRANTY**

---

MK DIAMOND PRODUCTS, INC. will guarantee every machine they build, to be free from defects in material and workmanship for (1) one year from date of purchase. The obligation of MK DIAMOND PRODUCTS, INC. under this warranty is limited to the repair or replacement of any parts which, under normal use, prove to be defective in material or workmanship. The parts involved or the unit in question should be returned to MK DIAMOND PRODUCTS, INC. or to a point designated by us, transportation prepaid.

This warranty does not obligate us to bear the cost of labor or transportation charges in connection with replacement or repair of defective parts. Likewise, it shall NOT apply to any unit which has been subjected to misuse, neglect or accident. This warranty does NOT apply to any machine which has been repaired or altered outside our factory.

This warranty does NOT obligate MK DIAMOND PRODUCTS, INC., with respect to items not of our manufacture, such as engines, motors, hydraulics, etc., which are subject to their own guarantees and warranties.

We shall in no event be liable for consequential damages or contingent liabilities arising out of failure of any equipment or parts to operate properly.

**© COPYRIGHT 2014, MK DIAMOND PRODUCTS, INC. ALL RIGHTS RESERVED.**

The MK Diamond logo is a registered trademark of MK Diamond Products, Inc. and may not be used, reproduced, or altered without written permission. All other trademarks are the property of their respective owners and used with permission.

MK Diamond may have patents, patent applications, trade marks, copyrights of other intellectual property right covering this product in this document.

This manual MUST accompany the equipment at all times. This manual is considered a permanent part of the equipment and should remain with the unit if resold.

The information and specifications included in this publication were in effect at the time of approval for printing.

**MK-2000 GAS SAW SERIES**  
**OWNER'S MANUAL, OPERATING**  
**INSTRUCTIONS & PARTS LIST**



**MK Diamond Products, Inc.**

MK Diamond Products, Inc.  
1315 Storm Parkway  
Torrance, CA 90501

Toll-Free: (800) 421-5830  
Phone: (310) 539-5221  
Fax: (310) 539-5158  
[www.mkdiamond.com](http://www.mkdiamond.com)