

MK-212 SERIES OWNERS MANUAL & OPERATING INSTRUCTIONS



MK-212-4



MK-212-6

Revision 303	03.2012
Manual Part No. 159862	

Caution: Read all safety and operating instructions before using this equipment. This owners manual **MUST** accompany the equipment at all times.

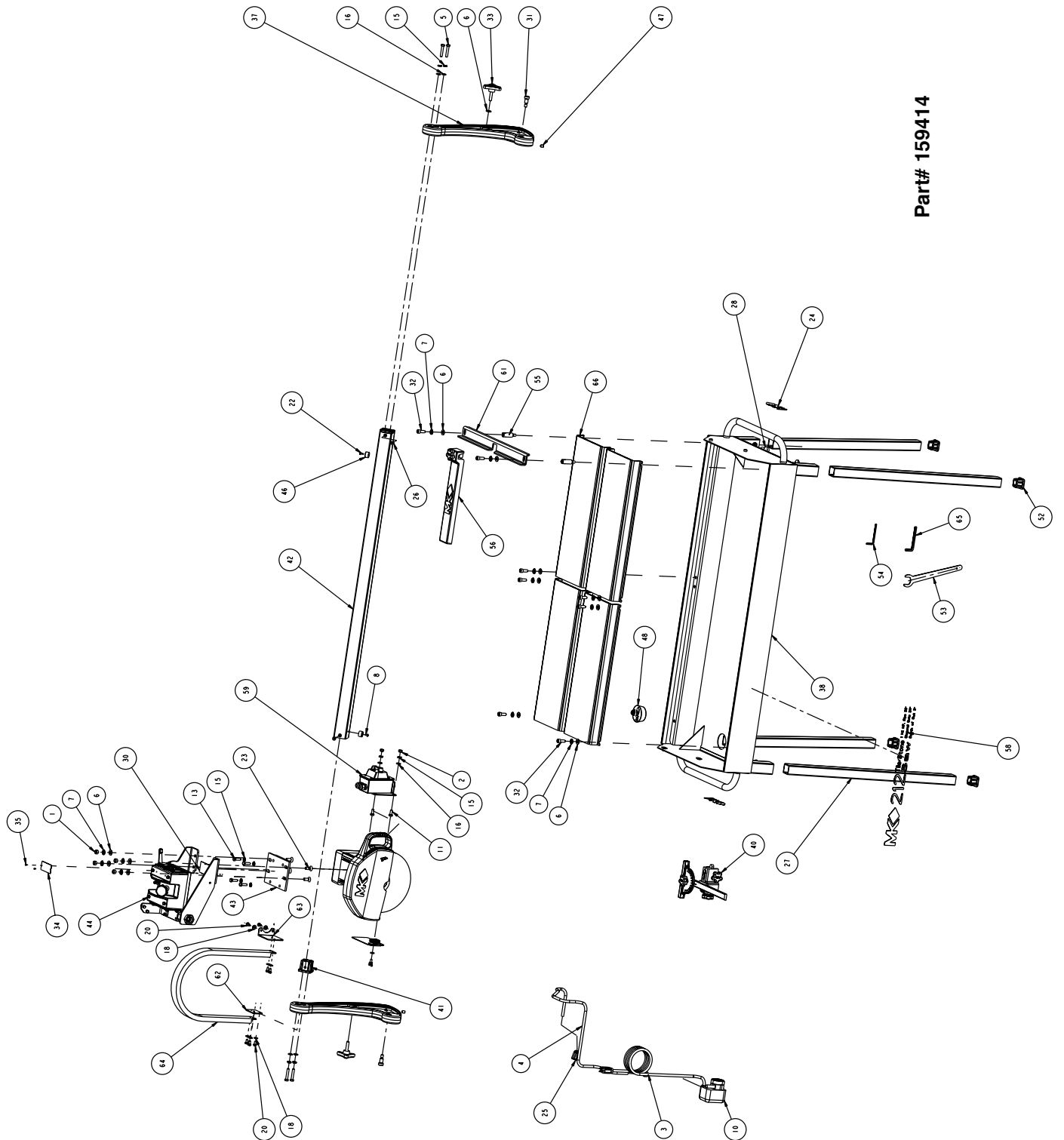

Part# 159414

ITEM NO.	DESCRIPTION	PART #	QTY. REQ.
1	NUT, 3/8-6 HEX	101188	4
2	NUT, HEX, 5/16 - 18	101196	2
3	FITTING, PLASTIC, 1/4 FNPT X 1/4 BARB	128397	1
4	HOSE, VINYL, 3/8 X 1/4	132951	1
5	SCREW, 5/16 - 18 X 1-3/4 HEX HEAD CAP	150919	4
6	WASHER, 3/8 SAE FLAT	150923	15
7	WASHER, 3/8 SPLIT LOCK	150925	12
8	SCREW, PAN HD SELF TPIO-24 X 3/8	151262	1
9	BOLT, HEX HEAD 1/4 20 X 3/4"	151267	4
10	PUMP, WATER 115V/60HZ UL/CSA	151271	1
11	SCREW, 5/16 - 18 X 1 HEX HEAD MACHINE	151743	4
12	KNOB, 5/16-18 X 1	151681	1
13	SCREW, 5/16 -18 X 1 HEX HEAD MACHINE	151743	4
14	WINGNUT, 5/16 - 18 NYLOK	151746	1
15	WASHER, LOCK, SPLIT, 5/16	151747	10
16	WASHER, 5/16 SAE FLAT	151754	8
17	SCREW, WING, 1/4 - 20 X 1/2	151888	1
18	WASHER, 1/4 SAE FLAT	151915	13
19	WASHER, 1/4 SPLIT LOCK	152591	4
20	SCREW, 1/4 - 20 X 1/2 HEX HEAD	152608	8
21	STUD, 5/16 - 18 X 1-1/2"	153680	1
22	SCREW, PHILP SELF TAP 10 - 24 X 5/8"	153681	1
23	F.H.C.S. 3/8 - 16 X 1"	154019	4
24	LABEL, 1-3/4 X 5 MK LOGO	154335	2
25	CLAMP, HOSE 1/2 - 3/4	154394	1
26	SCREW, 1/4 - 20 X 3/4 FLAT HEAD PHILLIPS MACHINE	154657	4
27	LEG	155397	4
28	SCREW, THUMB 3/8 - 16 X 3/4"	155398	4
30	LABEL, SAFETY	155806	1
31	SCREW, SHLDR, SOC HD, 1/2 X 3/4	156177	2
32	SCREW, SOCKET HEAD CAP 3/8 - 16 X 1	156602	1
33	KNOB, TRI	156770-02	2
34	TAG, SERIAL #, BLANK	157500-RW	1
35	DRIVE SCREW, #7 X 5/16 ROUND HEAD	157849	2
36	GUARD, BLADE	159416	1

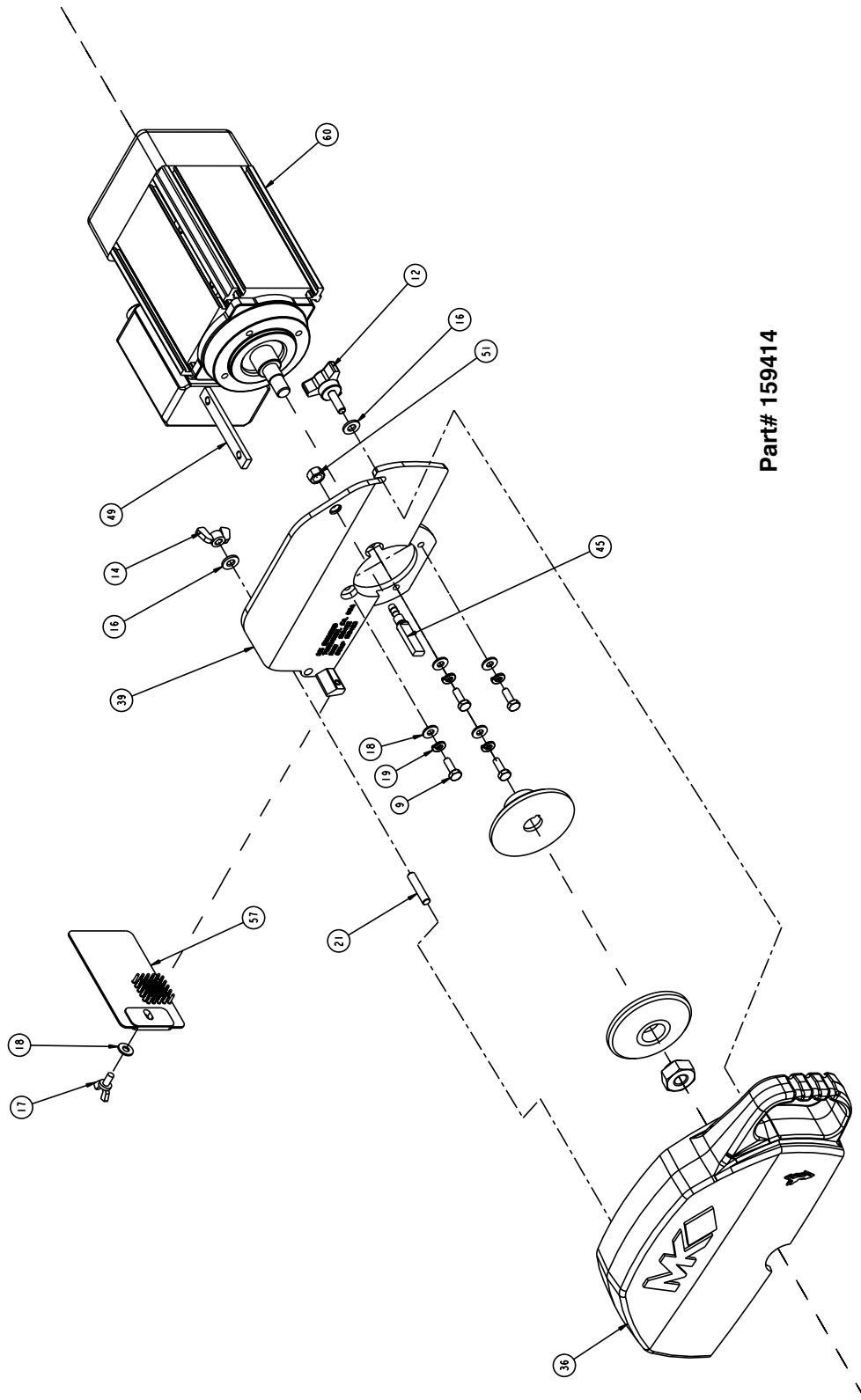

ITEM NO.	DESCRIPTION	PART #	QTY. REQ.
37	POST, PIVOT (COMP)	159418	2
38	FRAME, PAN WELDMENT	159419	4
39	GUARD, INNER BLADE (COMP)	159423	1
40	PROTRACTOR ASSEMBLY	159572	1
41	BLOCK, RAIL	159622	2
42	RAIL, 2 X 2 X 50	159641	1
43	MOUNT, SOGA MOTOR	159642	1
44	CUTTING HEAD	159853	1
45	MANIFOLD, WATER	159854	1
46	STOP, RUBBER BUMPER	159855	2
47	SCREW, SET UP 3/8 - 16 X 1/2"	159856	2
48	PLUG, 2-1/2 DIA RUBBER	159858	1
49	KEY, MOTOR MOUNT	159859	2
50	OWNERS MANUAL	159862	1
51	NUT, 3/8 16 HEX	159863	1
52	FOOT, RUBBER	159977	4
53	WRENCH, 30MM OPEN END, 30DEG	159979	1
54	WRENCH, 5MM ALLEN	159979	1
55	STAND OFF, BACK STOP	160117	2
56	ASSEMBLY, RIP GUIDE	160288	1
57	GUARD, SPLASH	160310	1
58	LABEL, MK-212	160669	2
59	SWITCH BOX	160687	1
60	2 H.P. SOGA 115V MOTOR	162078	1
61	STOP, BACK	165685	1
62	BRACKET, POST MOUNT	167376	1
63	BRACKET, HEAD MOUNT	167377	1
64	CARRIER, CABLE	167430	1
65	WRENCH, 5/16"ALLEN	167679	1
66	ASSEMBLY, TABLE	167762	2

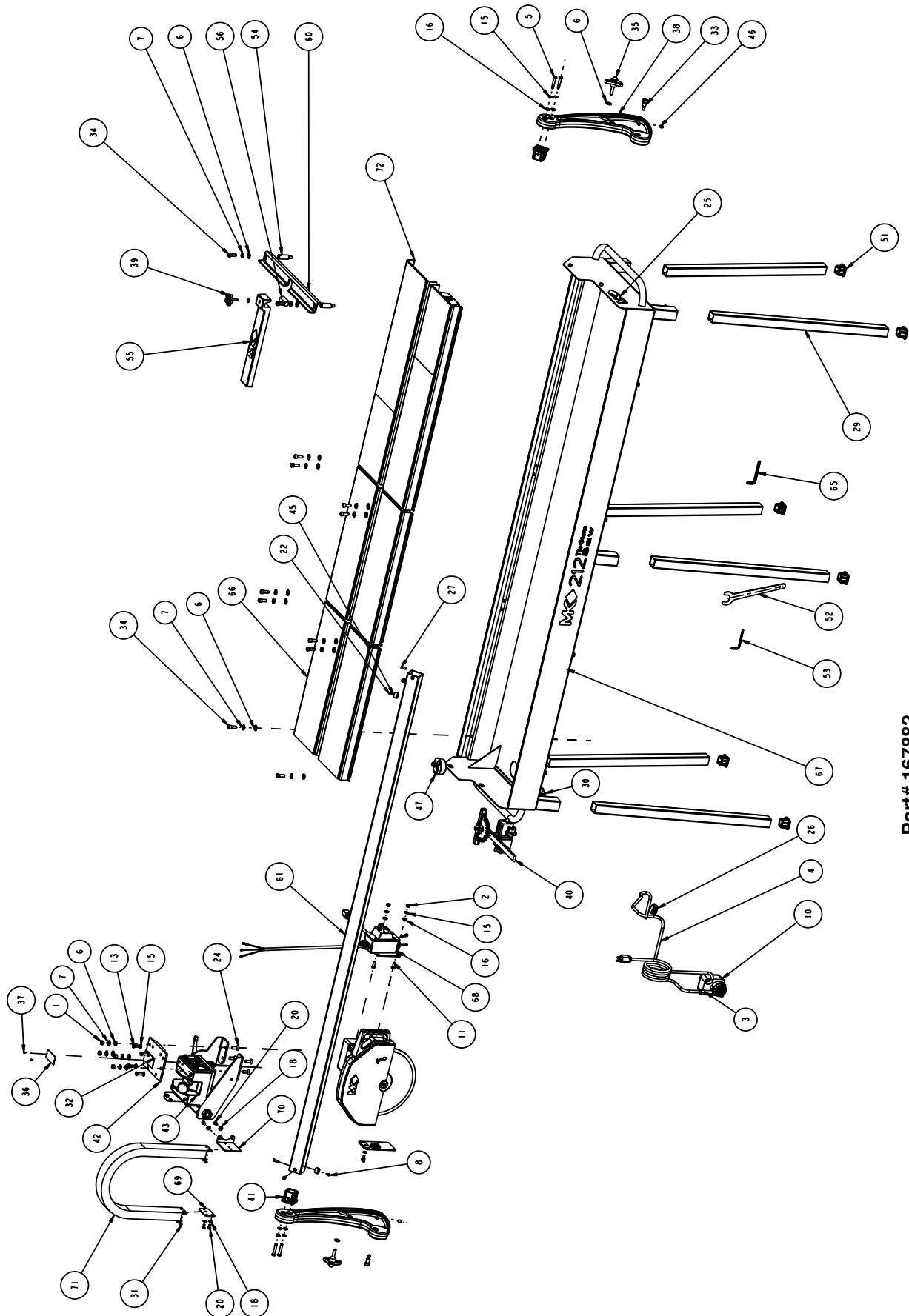

Part# 167882

ITEM NO.	DESCRIPTION	PART #	QTY. REQ.
1	NUT, 3/8 - 16 HEX	101188	4
2	NUT, HEX, 5/16 - 18	101196	2
3	FITTING, PLASTIC, 1/4 FNPT X 1/4 BARB	128397	1
4	HOSE, VINYL, 3/8 X 1/4	132951	1
5	SCREW, 5/16 - 18 X 1-3/4 HEX HEAD CAP	150919	4
6	WASHER, 3/8 SAE FLAT	150923	18
7	WASHER, 3/8 SPLIT LOCK	150925	16
8	SCREW, PAN HD SELF TP10-24 X 3/8	151262	1
9	BOLT, HEX HEAD 1/4 - 20 X 3/4"	151267	4
10	PUMP, WATER 115V/60HZ UL/CSA	151271	1
11	SCREW, 5/16 - 18 X 3/4 HEX HEAD MACHINE	151369	2
12	KNOB, 5/16 - 18 X 1	151681	1
13	SCREW, 5/16 - 18 X 1 HEX HEAD MACHINE	151743	4
14	WINGNUT, 5/16 - 18 NYLON	151746	1
15	WASHER, LOCK, SPLIT, 5/16	151747	10
16	WASHER, 5/16 SAE FLAT	151754	8
17	SCREW, WING, 1/4 - 20 X 1/2	151888	1
18	WASHER, 1/4 SAE FLAT	151915	10
19	WASHER, 1/4 SPLIT LOCK	152591	4
20	SCREW, 1/4 - 20 X 1/2 HEX HEAD	152608	4
21	STUD, 5/16 - 18 X 1-1/2"	153680	1
22	SCREW, PHILP SELF TAP 10 - 24 X 5/8"	153681	1
23	CARTON, SHIPPING	153738	1
24	F.H.C.S. 3/8 - 16 X 1"	154019	4
25	LABEL, 1-3/4 X 5 MK LOGO	154335	2
26	CLAMP, HOSE 1/2 - 3/4	154394	1
27	SCREW, 1/4 - 20 X 3/4 FLAT HEAD PHILLIPS MACHINE	154657	4
29	LEG	155397	6
30	SCREW, THUMB 3/8 - 16 X 3/4"	155398	6
31	SCREW, 1/4-20 X 1/2 PAN HEAD PHILLIPS MACHINE	155452	4
32	LABEL, SAFETY	155806	1
33	SCREW, SHLDR, SOC HD, 1/2 X 3/4	156177	2
34	SCREW, SOCKET HEAD CAP 3/8 - 16 X 1	156602	12
35	KNOB, TRI	156770-02	2
36	TAG, SERIAL #, BLANK	157500-RW	1
37	DRIVE SCREW, #7 X 5/16 ROUND HEAD	157849	2

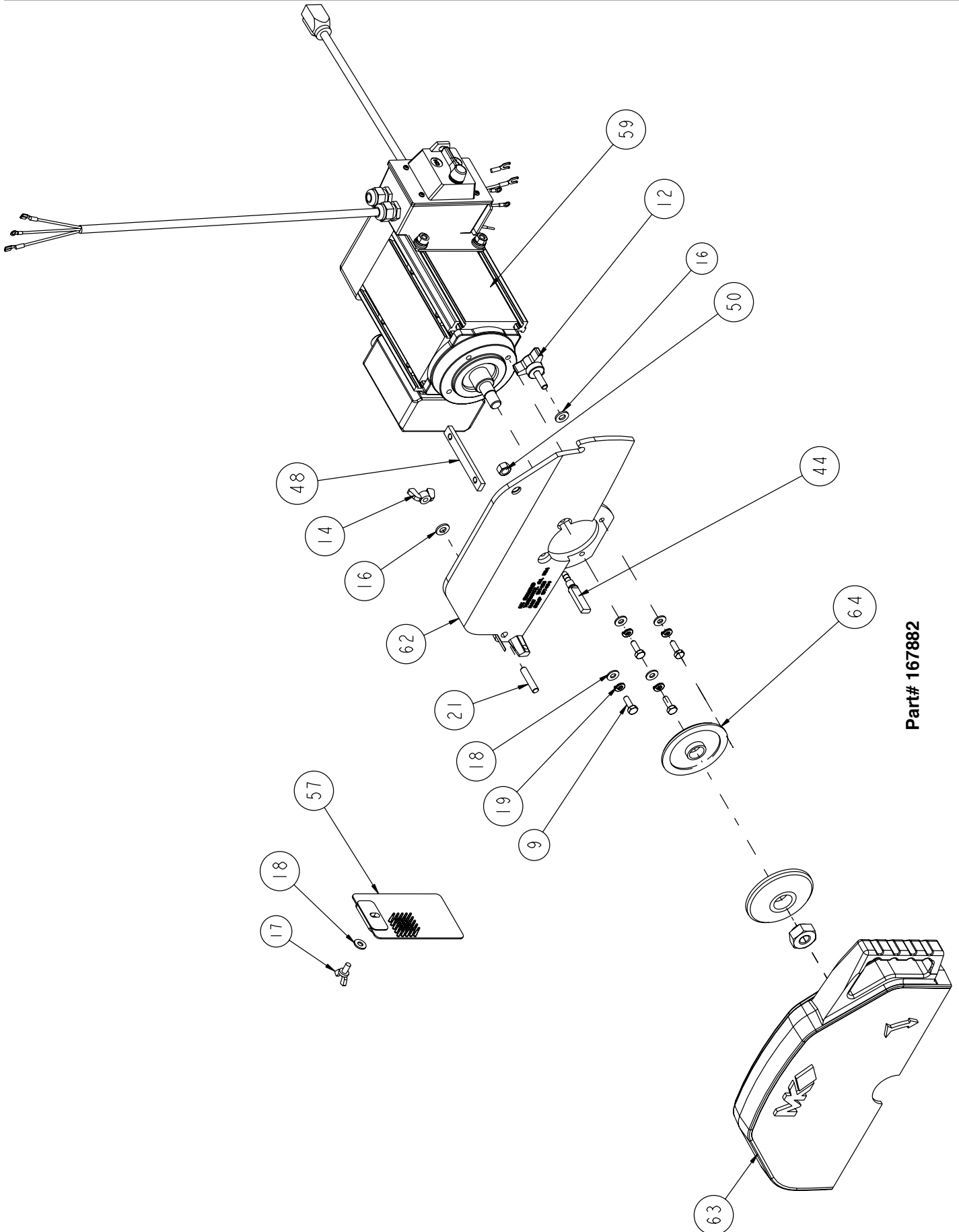

Part# 167882

ITEM NO.	DESCRIPTION	PART #	QTY. REQ.
38	POST, PIVOT (COMP)	159418	2
39	KNOB, 1/4 - 20 X 1 - 1/4	159428-2	1
40	PROTRACTOR ASSEMBLY	159572	1
41	BLOCK, RAIL	159622-MOD	2
42	MOUNT, SOGA MOTOR	159642	1
43	CUTTING HEAD	159853	1
44	MANIFOLD, WATER	159854	1
45	STOP, RUBBER BUMPER	159855	2
46	SCREW, SET CUP 3/8 - 16 X 1/2"	159856	2
47	PLUG, 2-1/2 DIA RUBBER	159858	1
48	KEY, MOTOR MOUNT	159859	2
49	OWNER MANUAL	159862	1
50	NUT, 3/8 - 16 HEX	159863	1
51	FOOT, RUBBER	159977	6
52	WRENCH, 30MM OPEN END, 30 DEG	159978	1
53	WRENCH, 5MM ALLEN	159979	1
54	STAND OFF, BACK STOP	160117	2
55	GUIDE, 15 INCH RIP (COMP)	160286	1
56	PLATE, PRESSURE	160287	1
57	GUARD, SPLASH	160310	1
58	LABEL, MK-212	160669	1
59	MOTOR, 115V, 2HP SOGA	162078	1
60	STOP, BACK	165685	
61	RAIL	166887	1
62	GUARD, BLADE INNER	167494	1
63	GUARD, BLADE OUTER	167496	1
64	FLANGE, BLADE INNER	167539	1
65	WRENCH, 5/16" ALLEN	167679	1
66	ASSEMBLY, TABLE	167762	2
67	PAN WELDMENT	167883	1
68	ASS'Y, SWITCH BOX	167893	1
69	BRACKET, POST MOUNT	168048	1
70	BRACKET, HEAD MOUNT	168049	1
71	CARRIER, CABLE	168051	1
72	ASSEMBLY, TABLE LONG	168054	1

Part# 159853

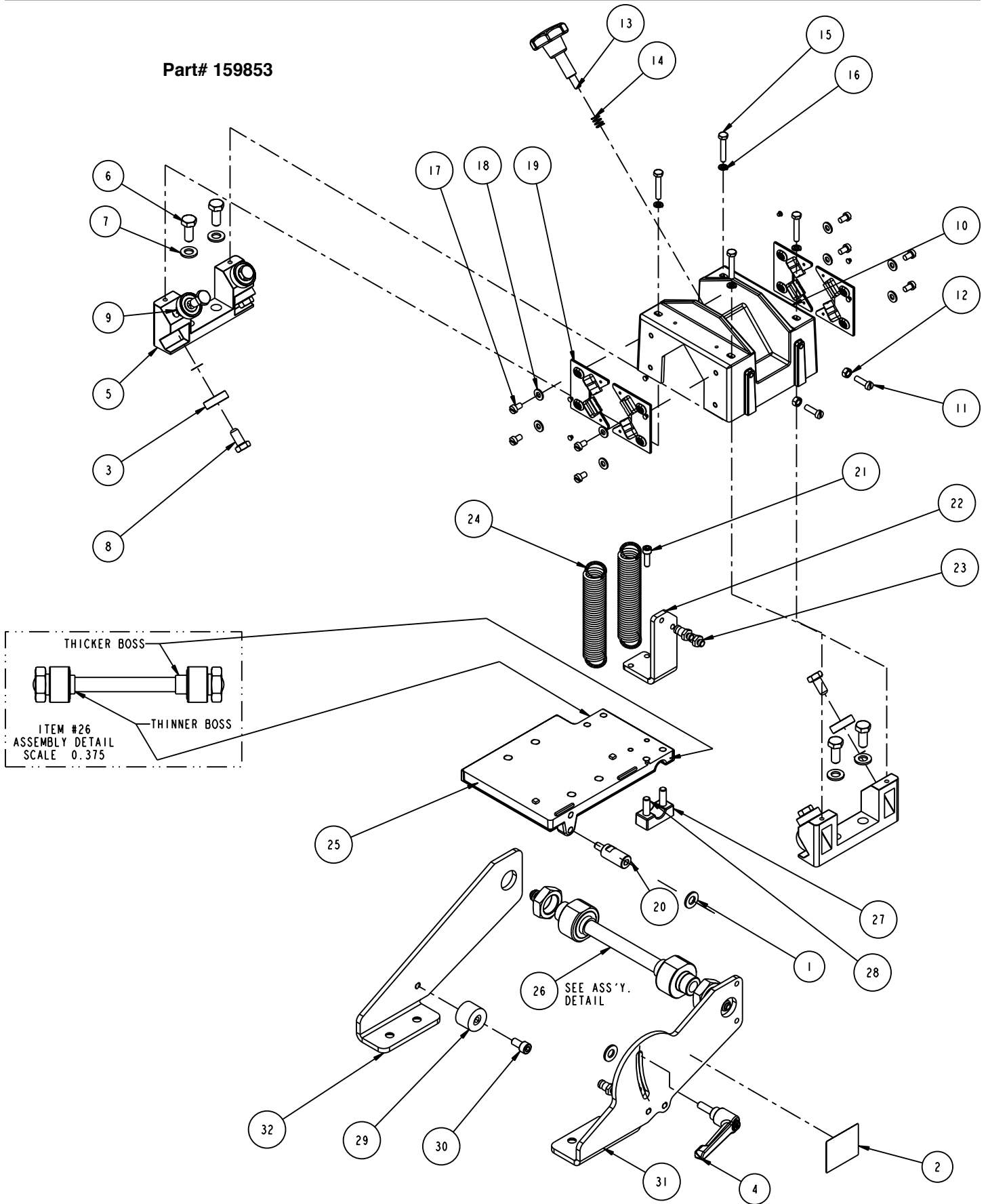

ITEM NO.	DESCRIPTION	PART #	QTY. REQ.
1	WASHER, 3/8 SAE FLAT	150923	2
2	LABEL, FOR INFO ON SERVICE	155038	1
3	BEARING, BALL, DEEP GROOVE	160097	8
4	KNOB, ADJUSTMENT	160184	1
5	BLOCK, BEARING RAIL (COMP)	160201	2
6	SCREW, HEX HEAD CAP, M10 X 30MM	160202	4
7	WASHER, FLAT, N, M10	160203	4
8	SCREW, HEX HEAD CAP M10 X20MM	160204	8
9	SHIM, 3/8 X 5/8 X .008 STEEL	160205	8
10	COVER, BEARING (COMP)	160207	1
11	SCREW, SLOTTED MACHINE M6 X 20MM	160208	2
12	NUT, HEX, M6 X 1.0	160209	2
13	KNOB, LOCKING	160210	1
14	SPRING, COMPRESSION	160211	1
15	SCREW, HEX HEAD CAP, M6 X 30MM	160212	4
16	WASHER, SPLIT M6	160213	4
17	SCREW, PAN HEAD SLOT M6 X 10MM	160214	8
18	WASHER, FLAT M6	160215	8
19	ASSEMBLY, WIPER, CUTTING HEAD	160216	4
20	STAND-OFF, BEARING SUPPORT BASE	160218	1
21	SHCS M6 X 20	160219	2
22	BRACKET, SPRING SUPPORT	160220	1
23	PIN, SPRING SUPPORT	160221	4
24	SPRING	160222	2
25	BASE, BEARING SUPPORT	160223	1
26	ASSY, CUTTING HEAD PIVOT AXLE	160224	1
27	CLAMP, PIVOT AXLE	160226	2
28	SCREW, SOCKET HEAD CAP M8 X 25MM	160227	4
29	STOP, RUBBER BUMPER	160228	1
30	SCREW, SOCKET HEAD CAP M8 X 16MM	160229	1
31	ARM, MK-212 SWING (LEFT)	160238	1
32	ARM, MK-212 SWING (RIGHT)	160242	1

ITEM	NUMBER	DESCRIPTION	
1.	Various	MK-275, Marble Profile Wheel	
2.	153495 155129	MK-415, 10" or 12" Diamond Blade	
3.	137471 151296	MK-62M, 10" or 12" Diamond Blade for Marble	
4.	151403 150789	MK-62G 10" or 12" Diamond Blade for Granite	
5.	152792	Dressing Stone	
6.	152610	Ground Fault Circuit Interrupter	
7.	165884	Side Table - MK-212-4 Side Table - MK-212-6	
8.	166271	Foot Switch	
9.	160172	Transport Wheels	

ORDERING INFORMATION

You may order MK Diamond products through your local MK Diamond distributor or, you may order direct from MK Diamond.

When ordering direct from MK Diamond, please have the following information ready before calling:

- The Model Number of the saw
- The Serial Number of the saw
- Where the saw was purchased and when
- The Part Number for the part(s) being ordered
- The Part Description for the part(s) being ordered

NOTE: There is a \$25.00 minimum order when ordering direct from MK Diamond. A \$5.00 charge will be added to orders having a net billing value under \$50.00. All purchases must be made using VISA, MasterCard or American Express.

All parts may be ordered by calling toll free to – 800 421-5830 or 310 539-5221 and asking for Customer Service. For technical questions, call – 800 474-5594.

RETURN MATERIALS POLICY

To expedite the service relative to the return of a product purchased through MK Diamond, please observe the following:

NOTE: When returning all items, they must have been purchased within the previous twelve (12) months.

- Have the Model Number of the saw
- Have the Serial Number of the saw
- Have the location of where the saw was purchased
- Have the date when the saw was purchased
- Contact Customer Service for approval to return the item(s)
- Obtain a Returned Goods Number (RGA) authorizing the return
- Follow the packaging instructions in the following section
- Ensure your item(s) are prepaid to the destination

For returned items, call toll free to – 800 421-5830 or 310 539-5221 and ask for Customer Service. For technical questions, call – 800 474-5594 or 310 257-2845.

PACKAGING INSTRUCTIONS

- Remove the Cutting Head and Support Angle Assembly
- Dry the saw before shipping
- When packing, include the following: Saw, Diamond Blade, Blade Guard and Support Angle Assembly and Adjustable Cutting Guide (Other Accessories are not required)
- Package the unit in its original container or one of comparable size (do not ship the unit partially exposed)
- Ensure all parts are secured in the packaging to prevent moving

AUTHORIZED SERVICE CENTERS

For quicker repair time, you may contact MK Diamond Customer Service, toll free, at 800 421-5830 or 310 539-5221 for the Authorized Service Center closest to you or visit our web site at www.mkdiamond.com. For technical questions, call – 800 474-5594.

CONTACT

Please contact MK Diamond Products, Inc. Customer Service Department with any questions you might have regarding distributors, parts or service.

Telephone: **(800) 421-5830**

Fax: **(310) 539-5158**

E-mail: **Customer_Service@MKDiamond.com**

Customer Service Hours: **Monday through Friday, 6AM-4PM PST**

MK Diamond Products, Inc.

1315 Storm Parkway

Torrance, CA 90501

MK DIAMOND PRODUCTS, INC. LIMITED WARRANTY

MK DIAMOND PRODUCTS, INC. will guarantee every machine they build, to be free from defects in material and workmanship for (1) one year from date of purchase. The obligation of MK DIAMOND PRODUCTS, INC. under this warranty is limited to the repair or replacement of any parts which, under normal use, prove to be defective in material or workmanship. The parts involved or the unit in question should be returned to MK DIAMOND PRODUCTS, INC. or to a point designated by us, transportation prepaid.

This warranty does not obligate us to bear the cost of labor or transportation charges in connection with replacement or repair of defective parts. Likewise, it shall NOT apply to any unit which has been subjected to misuse, neglect or accident. This warranty does NOT apply to any machine which has been repaired or altered outside our factory.

This warranty does NOT obligate MK DIAMOND PRODUCTS, INC., with respect to items not of our manufacture, such as engines, motors, hydraulics, etc., which are subject to their own guarantees and warranties.

We shall in no event be liable for consequential damages or contingent liabilities arising out of failure of any equipment or parts to operate properly.

© COPYRIGHT 2012, MK DIAMOND PRODUCTS, INC. ALL RIGHTS RESERVED.

The MK Diamond logo is a registered trademark of MK Diamond Products, Inc. and may not be used, reproduced, or altered without written permission. All other trademarks are the property of their respective owners and used with permission.

MK Diamond may have patents, patent applications, trade marks, copyrights of other intellectual property right covering this product in this document.

This manual MUST accompany the equipment at all times. This manual is considered a permanent part of the equipment and should remain with the unit if resold.

The information and specifications included in this publication were in effect at the time of approval for printing.

MK-212 SERIES SAW
OWNERS MANUAL & OPERATING INSTRUCTIONS



MK Diamond Products, Inc.

MK Diamond Products, Inc.
1315 Storm Parkway
Torrance, CA 90501

Toll-Free: (800) 841-5830
Phone: (310) 539-5221
Fax: (310) 539-5158
www.mkdiamond.com