



MK Diamond Products, Inc.

www.mkdiamond.com

MK-DDG SERIES OWNER'S MANUAL, PARTS LIST & OPERATING INSTRUCTIONS



MK-DDG-11



MK-DDG-5

| | |
|---------------|---------|
| Revision 203 | 12.2011 |
| Manual 157499 | |

Caution: Read all safety and operating instructions before using this equipment. This parts list **MUST** accompany the equipment at all times.



MK Diamond Products, Inc.

EXPLODED VIEW WITH GAS ENGINE

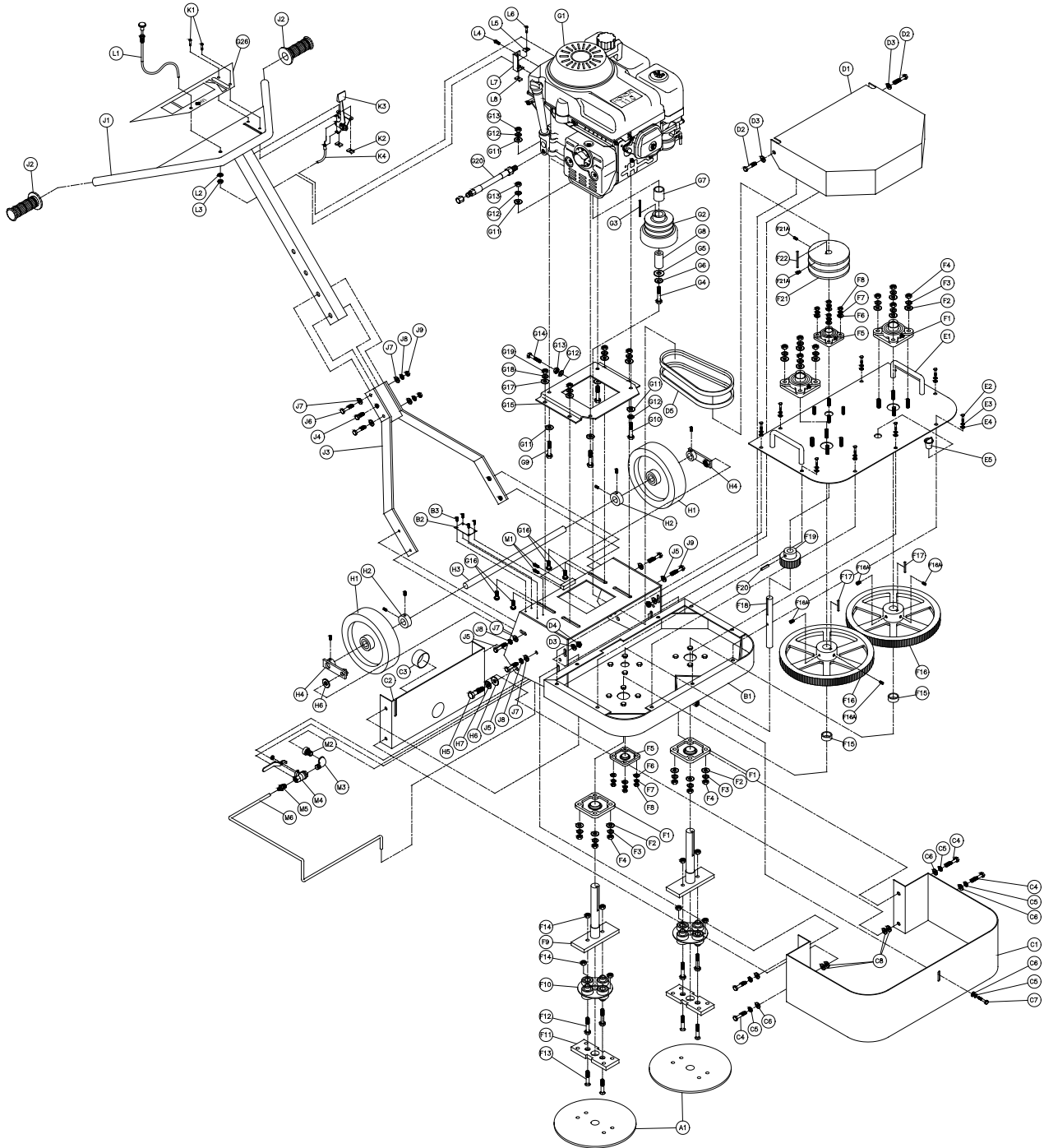

EXPLODED VIEW WITH ELECTRIC MOTOR

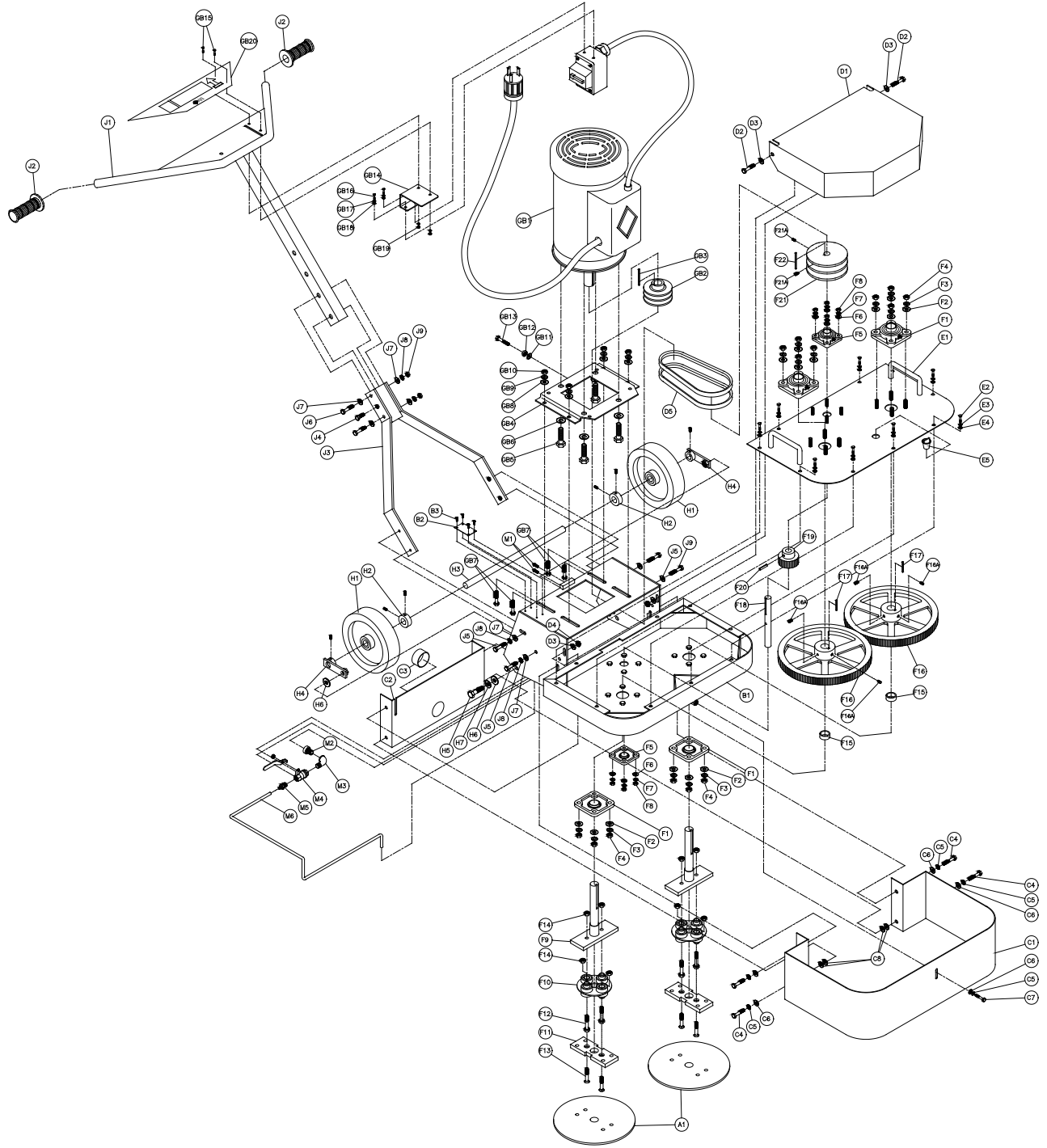

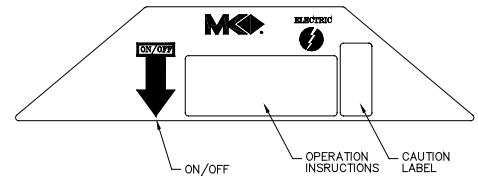
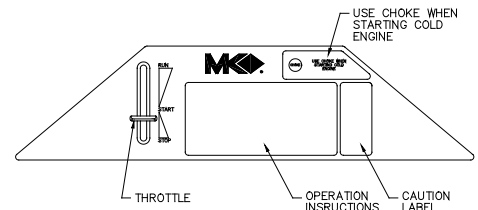
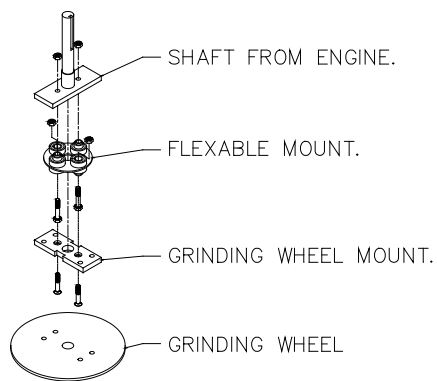
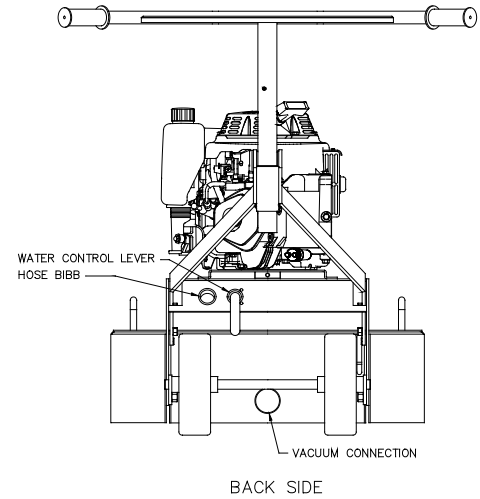
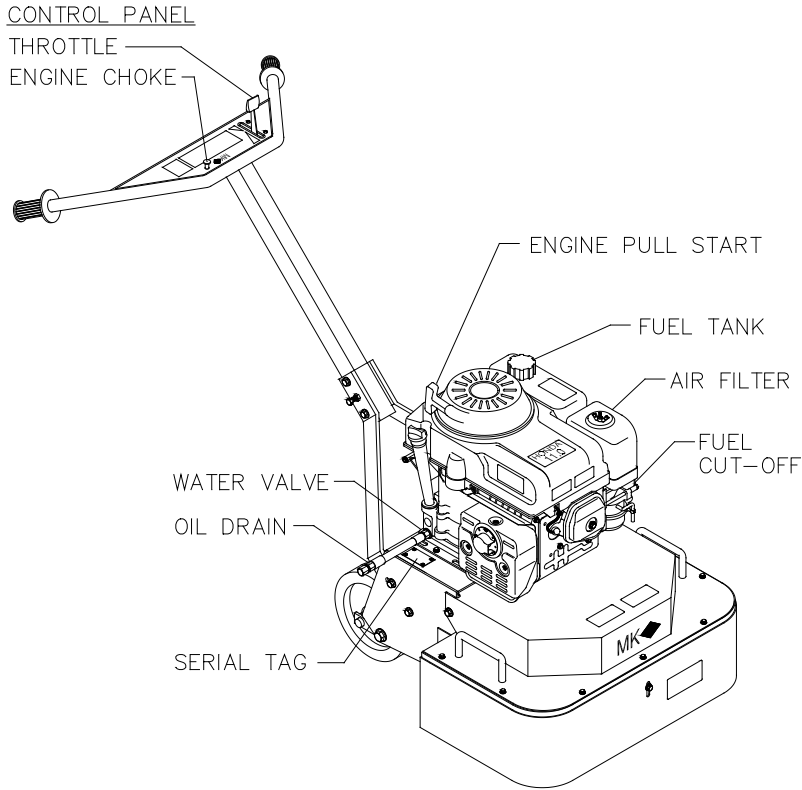





| Item | Description | Part # | Qty |
|------|--|-----------|-----|
| A | Assembly, Accessory Pack | - | - |
| A1 | Grinding Wheels 10" (Reference only) | reference | 0 |
| A2 | Pallet (not shown) | 157700 | 1 |
| A3 | Carton, DDG-11 Grinder (not shown) | 157701 | 1 |
| A4 | Carton, DDG-11 Top (not shown) | 158369 | 1 |
| A5 | Carton, DDG-11 Inserts (not shown) | 158370 | 2 |
| A6 | Tube, Owner's Manual (not shown) | 155419 | 1 |
| A7 | Manual, Owner's (not shown) | 157499 | 1 |
| A8 | Bolt, Hex HD, 3/8-24 x 1 Grinding Disk, Mounting | 157803 | 8 |
| A9 | Washer, 3/8 Split Lock | 150925 | 8 |
| A10 | Washer, 3/8 Flat SAE | 150923 | 8 |
| B | Assembly, Frame | 157381 | 1 |
| B1 | Frame Weldment | 157068 | 1 |
| B2 | Plate, Serial Number | 157500 | 1 |
| B3 | #7 X 5/16 Drive Screw | 157849 | 4 |
| B4 | Label, Water Shut Off/On | 154404 | 1 |
| C | Assembly, Apron | - | 1 |
| C1 | Apron, | 157064 | 1 |
| C2 | Plate, Vacuum | 157255 | 1 |
| C3 | Cap, Vacuum Attachment | 157503 | 1 |
| C4 | Screw, 5/16-18 x 1-1/4 Hex Head | 153950 | 4 |
| C5 | Washer, 5/16 lock, split | 151747 | 5 |
| C6 | Washer, 5/16 SAE Flat | 151754 | 5 |
| C7 | Screw, 5/16-18 x 3/4 Hex Head | 151369 | 1 |
| C8 | Label, Caution, Hands and Feet | 155585 | 1 |
| D | Assembly, Belt Guard | - | 1 |
| D1 | Guard, Belt | 157069 | 1 |
| D2 | Screw, 1/4-20 X 1 Hex Head Cap | 152676 | 2 |
| D3 | Washer, 1/4 SAE Flat | 151915 | 4 |
| D4 | Nut, Hex W/ WSHR 1/4-20 (KEPS) | 153941 | 2 |
| D5 | V-Belt (V AX-25) | 152403 | 2 |
| D6 | Label, MK Logo Adhesive | 157914 | 1 |
| D7 | Label, Caution, Belt Tension | 155583 | 1 |
| D8 | Label, Caution, Guards in Place | 155587 | 1 |
| E | Assembly, Gear, Cover | - | 1 |
| E1 | Cover, Gear | 157066 | 1 |
| E2 | Screw, 1/4-20 x 3/4 Hex Head Cap | 152370 | 9 |
| E3 | Washer, 1/4 Split Lock | 152591 | 9 |
| E4 | Washer, 1/4 SAE Flat | 151915 | 9 |
| E5 | Cap, Grease | 157915 | 1 |
| F | Assembly, Components, Gear Box | - | - |
| F1 | Flange unit, 1" dia 4 Bolt (Bearing) | 157305 | 4 |
| F2 | Washer, 7/16 Flat SAE | 151050 | 16 |
| F3 | Washer, 7/16 Split Lock | 151051 | 16 |

| Item | Description | Part # | Qty |
|------|--|------------------|--------|
| F4 | Nut, 7/16-14, Hex | 150922 | 16 |
| F5 | Flange unit, 3/4" dia 4 Bolt (Bearing) | 157304 | 2 |
| F6 | Washer, 3/8 Flat SAE | 150923 | 8 |
| F7 | Washer, 3/8 Split Lock | 150925 | 8 |
| F8 | Nut, 3/8-16, Hex | 101188 | 8 |
| F9 | Shaft, 1" dia Large Gear | 157302 | 2 |
| F10 | Flexible Mount, Morflex (Morse 402 Insert) | 157411 | 2 |
| F11 | Mount, Grinding Wheel | 157407 | 2 |
| F12 | Screw, 3/8-16 x 2 1/2 Hex HD Cap | 156030 | 4 |
| F13 | Screw, 3/8-16 x 2 1/2 Flt. Soc. HD. | 157562 | 4 |
| F14 | Nut, 3/8-16, Hex Nylock | 152505 | 8 |
| F15 | Bushing, 1 1/4 OD x 1 ID x 1/2 Spacer | 157410 | 2 |
| F16 | Gear, 11 1/2" dia Spur (Cast 10P 112T-14 1/2 PA) | 157306 | 2 |
| F17 | Key, Square, 1/4 x 1/4 x 1 1/4" | 159852 | 2 |
| F18 | Shaft, 3/4" dia Small Gear | 157303 | 1 |
| F19 | Gear, 2 1/2" dia Spur (Steel 10P 25T-14 1/2 PA) | 157307 | 1 |
| F20 | Pin, 1/4 x 1 1/2" Rolled | 157565 | 1 |
| F21 | Pulley, 2AK51H F21A) Bushing, H 3/4 Q.D. | 159849 159850 | 1 1 |
| F22 | Key, Square, 3/16 x 3/16 x 1 3/4" | 157561 | 1 |
| G | Assembly, Engine, 11HP Honda | - | 1 |
| G1 | Engine, Honda GX340k2dx3 | 157067 | 1 |
| G2 | Clutch, 3 1/2" OD with 1" I.D. 3 1/2" 2 Groove Pulley, | 157309 | 1 |
| G3 | Key, Square, 1/4 x 1/4 x 1 1/2" | 157560 | 1 |
| G4 | Bolt, 7/16-20 x 3" Hex Head | 157678 | 1 |
| G5 | Washer, 1 1/2" USS | 157679 | 1 |
| G6 | Washer, 7/16 Split Lock | 151051 | 1 |
| G7 | Spacer, 1 1/4" OD, 1" I.D. x 1 3/8" | 157680 | 1 |
| G8 | Spacer, 1" OD, 1/2" I.D. x 2" | 157681 | 1 |
| G9 | Screw, 5/16-18 x 1 1/2" Hex Head Cap | 152467 | 2 |
| G10 | Bolt, 5/16-24 x 1" Hex Head Tap | 157646 | 2 |
| G11 | Washer, 5/16 SAE Flat | 101352 | 5 |
| G12 | Washer, 5/16 Split Lock | 151747 | 5 |
| G13 | Nut, 5/16-18 Hex | 101196 | 3 |
| G14 | Bolt, 5/16-18 x 2 3/4" Hex Head Tap | 156974 | 1 |
| G15 | Mount, Engine | 157071 | 1 |
| G16 | Screw, 3/8-16 x 1" Carriage Bolt | 157644 | 4 |
| G17 | Washer, 3/8 SAE Flat | 150923 | 4 |
| G18 | Washer, 3/8 Split Lock | 150925 | 4 |
| G19 | Nut, 3/8-16 Hex | 101188 | 4 |
| G20 | Hose, Oil Drain (20mm) | 157577-04 | 1 |
| G21 | Label, Caution, Hot Surface, 1.5 x 3.0 | 155578 | 1 |
| G22 | Label, Warning, Refueling, 1.5 x 3.0 | 155580 | 1 |
| G23 | Label, Danger, California, 1.5 x 3.0 | 155581 | 1 |
| G24 | Label, Danger, Lethal Exhaust, 1.5 x 3.0 | 155582 | 1 |
| G25 | Label, Caution, Sparkplug | 155579 | 1 |
| G26 | Label, Control Panel (Gas) | 157075 | 1 |

| Item | Description | Part # | Qty |
|------|---|--------|-----|
| GB | Assembly, 5hp Electric Motor | | - |
| GB1 | Motor, 5 hp 230v 60hz 1ph, Electric C' face (Lesson / Baldor) | 160107 | 1 |
| GB2 | Pulley, 2BK34X 1 1/8 | 160108 | 1 |
| GB3 | Key, Square, 1/4 x 1/4 x 1 3/4" | 150796 | 1 |
| GB4 | Mount, Engine | 157071 | 1 |
| GB5 | Screw, 1/2-13 x 1 1/4 UNC Hex Head | 153532 | 4 |
| GB6 | Washer, 1/2 Split Lock | 153524 | 4 |
| GB7 | Screw, 3/8-16 x 1" Carriage Bolt | 157644 | 4 |
| GB8 | Washer, 3/8 SAE Flat | 150923 | 4 |
| GB9 | Washer, 3/8 Split Lock | 150925 | 4 |
| GB10 | Nut, 3/8-16 Hex | 101188 | 4 |
| GB11 | Washer, 5/16 Split Lock | 151747 | 5 |
| GB12 | Nut, 5/16-18 Hex | 101196 | 3 |
| GB13 | Bolt, 5/16-18 x 2 3/4" Hex Head Tap | 156974 | 1 |
| GB14 | Bracket, Switchbox (previous #227269) | 160110 | 1 |
| GB15 | Screw, 1/4-20 x 3/4" Pan HD Phil Cap | 227270 | 2 |
| GB16 | Screw, 1/4-20 x 1/2 Hex Head Cap | 152608 | 2 |
| GB17 | Washer, 1/4 Split Lock | 152591 | 4 |
| GB18 | Washer, 1/4 SAE Flat | 151915 | 4 |
| GB19 | Nut, 1/4-20 Hex | 151893 | 2 |
| GB20 | Label, Control Panel, (Electric) | 160109 | 1 |
| H | Assembly, Axle | - | 1 |
| H1 | Wheel, 8"Dia. X2 | 155986 | 2 |
| H2 | Collar, 3/4 set | 153814 | 2 |
| H3 | Axle, 3/4 Dia. | 157065 | 1 |
| H4 | Mount, Wheel Shaft, | 157072 | 2 |
| H5 | Screw, 1/2-13 x 1 1/4 UNC Hex Head | 153532 | 2 |
| H6 | Washer, 1/2 SAE Flat | 150924 | 4 |
| H7 | Washer, 1/2 Split Lock | 153524 | 2 |
| J | Assembly, Handlebar (Top & Bottom) | - | 1 |
| J1 | Handlebar, Top | 157260 | 1 |
| J2 | Handgrip | 150842 | 2 |
| J3 | Handlebar, Bottom | 157070 | 1 |
| J4 | Screw, 3/8-16 X 1 Hex Head Cap | 152507 | 1 |
| J5 | Screw, 3/8-16 X 1 1/4 Hex Head Cap | 150774 | 4 |
| J6 | Screw, 3/8-16 X 3 Hex Head Cap | 153113 | 4 |
| J7 | Washer, 3/8 SAE Flat | 150923 | 8 |
| J8 | Washer, 3/8 Split Lock | 150925 | 6 |
| J9 | Nut, 3/8-16 Hex | 101188 | 2 |
| K | Assembly, Throttle, Honda | - | 1 |
| K1 | Screw, (Phil) Self Tap 10-24 x 5/8 | 153681 | 2 |
| K2 | Nut, 10-24 Clip | 155407 | 2 |
| K3 | Assembly, Throttle Head | 155406 | 1 |
| K4 | Cable, Throttle, Honda | 156640 | 1 |
| L | Assembly, Choke, Honda | - | 1 |

| Item | Description | Part # | Qty |
|------|---|--------|-----|
| L1 | Cable, Choke | 154210 | 1 |
| L2 | Washer, 3/8 SAE Flat | 150923 | 4 |
| L3 | Nut, 3/8-24 Hex, Jam | 156623 | 1 |
| L4 | Screw, 10-32 X 1/2" Pan Head Phillips Cap | 151052 | 1 |
| L5 | Clamp, Transmission Control | 154383 | 1 |
| L6 | Screw, (Phil) Self Tap 10-24 x 5/8 | 153681 | 1 |
| L7 | Clip, Choke Cable | 157504 | 1 |
| L8 | Nut, 10-24 Clip | 155407 | 1 |
| M | Assembly, Water Valve | - | 1 |
| M1 | Screw, 10-24 x 3/8 Phillips Head Self-Tapping Cap | 151262 | 2 |
| M2 | Fitting, Brass, 1/2 MNPT x Garden Hose Swivel | 151322 | 1 |
| M3 | Elbow, 1/2 MNPT 90° Street Galvanized | 150844 | 1 |
| M4 | Valve, Shut-Off, 1/2 FNPT x 1/2 FNPT | 153796 | 1 |
| M5 | Fitting, Brass, 1/2 MNPT x 1/4 Compression Fit | 157563 | 1 |
| M6 | Tube, 1/4 OD Copper | 157564 | 2' |

ACCESSORIES

| ITEM | NUMBER | DESCRIPTION | |
|------|--------|---|--|
| 1. | 151925 | 10 Segments 1010 S soft Bond; Hard Material; Cured or Old |  |
| 2. | 158151 | 10 Segments 1010 H Hard Bond; Soft Material; Green Asphalt |  |
| 3. | 151926 | 20 Segment 1020 S soft Bond; Hard Material; Cured or Old |  |
| 4. | 158182 | 20 Segments 1010 H Hard Bond; Soft Material; Green Asphalt |  |

ORDERING INFORMATION

You may order MK Diamond products through your local MK Diamond distributor or, you may order direct from MK Diamond.

When ordering direct from MK Diamond, please have the following information ready before calling:

- The Model Number of the saw
- The Serial Number of the saw
- Where the saw was purchased and when
- The Part Number for the part(s) being ordered
- The Part Description for the part(s) being ordered

NOTE: There is a \$25.00 minimum order when ordering direct from MK Diamond. A \$5.00 charge will be added to orders having a net billing value under \$50.00. All purchases must be made using VISA, MasterCard or American Express.

All parts may be ordered by calling toll free to – 800 421-5830 or 310 539-5221 and asking for Customer Service. For technical questions, call – 800 474-5594.

RETURN MATERIALS POLICY

To expedite the service relative to the return of a product purchased through MK Diamond, please observe the following:

NOTE: When returning all items, they must have been purchased within the previous twelve (12) months.

- Have the Model Number of the saw
- Have the Serial Number of the saw
- Have the location of where the saw was purchased
- Have the date when the saw was purchased
- Contact Customer Service for approval to return the item(s)
- Obtain a Returned Goods Number (RGA) authorizing the return
- Follow the packaging instructions in the following section
- Ensure your item(s) are prepaid to the destination

For returned items, call toll free to – 800 421-5830 or 310 539-5221 and ask for Customer Service. For technical questions, call – 800 474-5594 or 310 257-2845.

PACKAGING INSTRUCTIONS

- Remove the Cutting Head and Support Angle Assembly
- Dry the saw before shipping
- When packing, include the following: MK-DDG and Grinding Head (Other Accessories are not required)
- Package the unit in its original container or one of comparable size (do not ship the unit partially exposed)
- Ensure all parts are secured in the packaging to prevent moving

AUTHORIZED SERVICE CENTERS

For quicker repair time, you may contact MK Diamond Customer Service, toll free, at 800 421-5830 or 310 539-5221 for the Authorized Service Center closest to you or visit our web site at www.mkdiamond.com. For technical questions, call – 800 474-5594.

CONTACT

Please contact MK Diamond Products, Inc. Customer Service Department with any questions you might have regarding distributors, parts or service.

Telephone: **(800) 421-5830**

Fax: **(310) 539-5158**

E-mail: **Customer_Service@MKDiamond.com**

Customer Service Hours: **Monday through Friday, 6AM-4PM PST**

**MK Diamond Products, Inc.
1315 Storm Parkway
Torrance, CA 90501**

MK DIAMOND PRODUCTS, INC. LIMITED WARRANTY

MK DIAMOND PRODUCTS, INC. will guarantee every machine they build, to be free from defects in material and workmanship for (1) one year from date of purchase. The obligation of MK DIAMOND PRODUCTS, INC. under this warranty is limited to the repair or replacement of any parts which, under normal use, prove to be defective in material or workmanship. The parts involved or the unit in question should be returned to MK DIAMOND PRODUCTS, INC. or to a point designated by us, transportation prepaid.

This warranty does not obligate us to bear the cost of labor or transportation charges in connection with replacement or repair of defective parts. Likewise, it shall NOT apply to any unit which has been subjected to misuse, neglect or accident. This warranty does NOT apply to any machine which has been repaired or altered outside our factory.

This warranty does NOT obligate MK DIAMOND PRODUCTS, INC., with respect to items not of our manufacture, such as engines, motors, hydraulics, etc., which are subject to their own guarantees and warranties.

We shall in no event be liable for consequential damages or contingent liabilities arising out of failure of any equipment or parts to operate properly.

© COPYRIGHT 2011, MK DIAMOND PRODUCTS, INC. ALL RIGHTS RESERVED.

The MK Diamond logo is a registered trademark of MK Diamond Products, Inc. and may not be used, reproduced, or altered without written permission. All other trademarks are the property of their respective owners and used with permission.

MK Diamond may have patents, patent applications, trade marks, copyrights of other intellectual property right covering this product in this document.

This manual MUST accompany the equipment at all times. This manual is considered a permanent part of the equipment and should remain with the unit if resold.

The information and specifications included in this publication were in effect at the time of approval for printing.

MK-DDG SERIES
OWNER'S MANUAL, PARTS LIST &
OPERATING INSTRUCTIONS



MK Diamond Products, Inc.

MK Diamond Products, Inc.
1315 Storm Parkway
Torrance, CA 90501

Toll-Free: (800) 421-5830
Phone: (310) 539-5221
Fax: (310) 539-5158
www.mkdiamond.com