

www.mkdiamond.com

MK-SINGLE DISC GRINDER OWNERS MANUAL PARTS LIST & OPERATING INSTRUCTIONS



SDG-3



SDG-11

Revision 202	11.2011
Manual 158273	

Caution: Read all safety and operating instructions before using this equipment. This parts list **MUST** accompany the equipment at all times.

Gas Engine

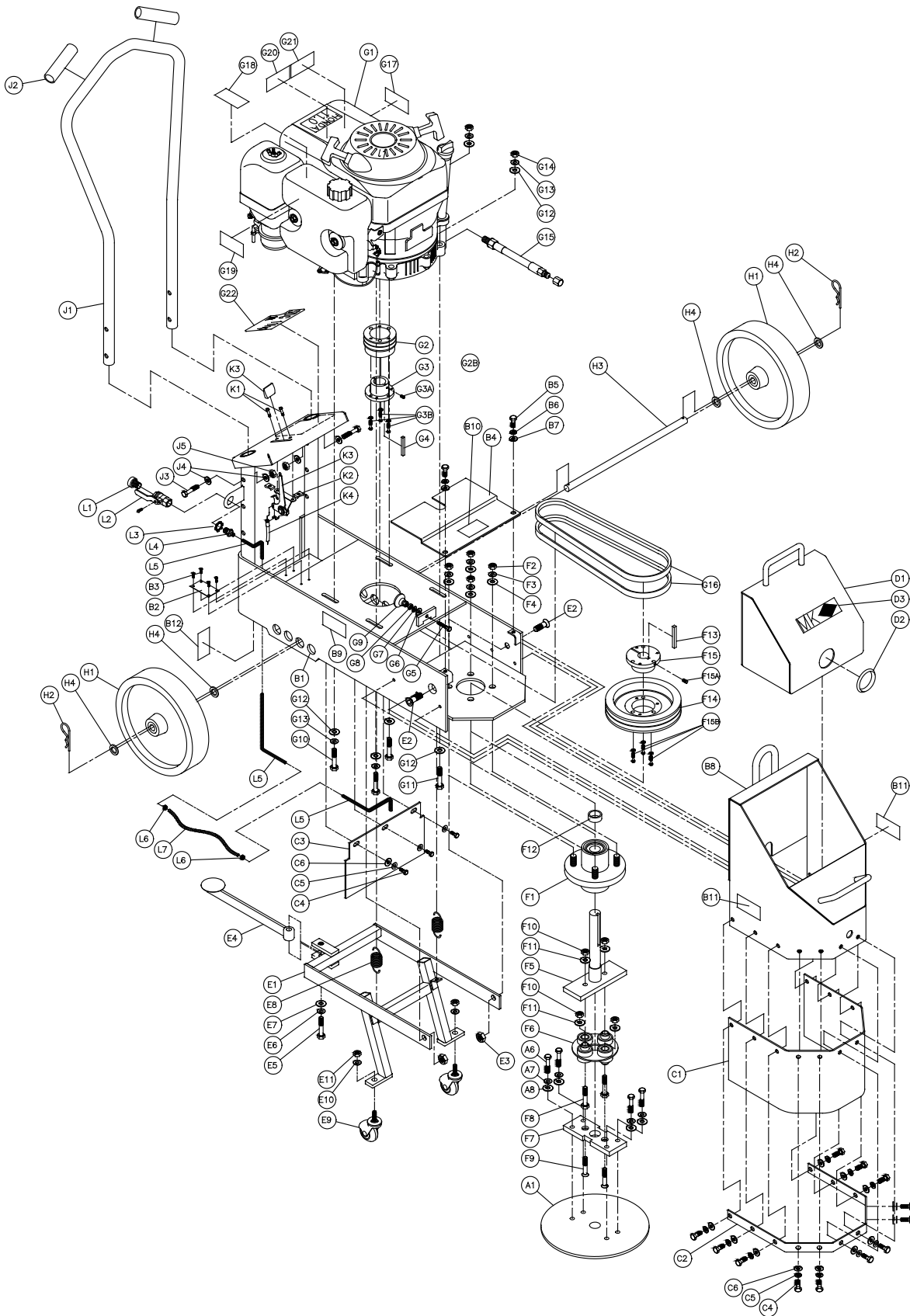

Gas Engine

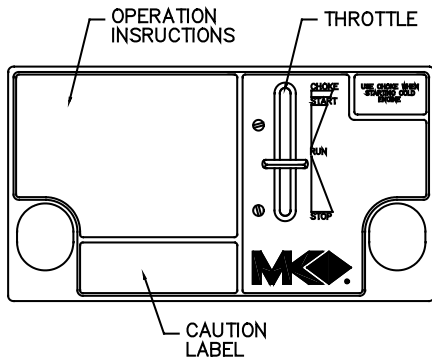

CONSOLE - GAS

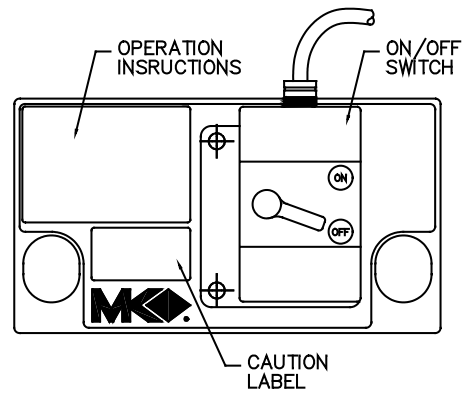

CONSOLE - ELECTRIC

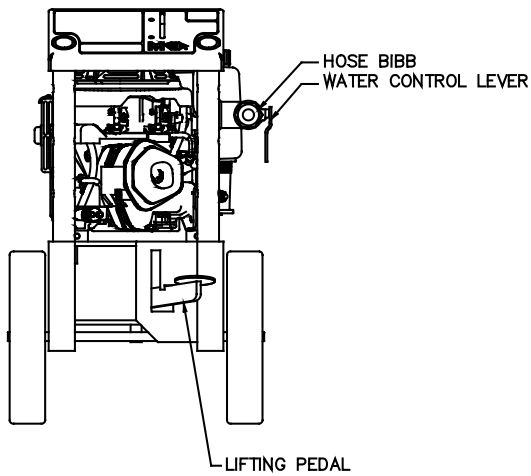

BACK SIDE

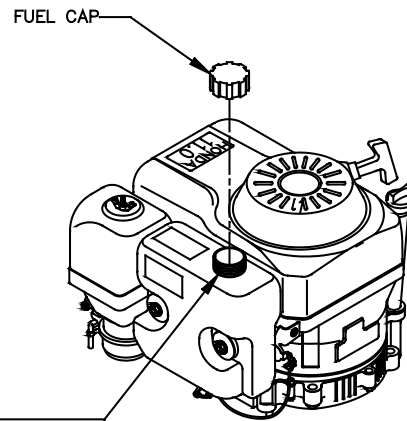

FUEL TANK

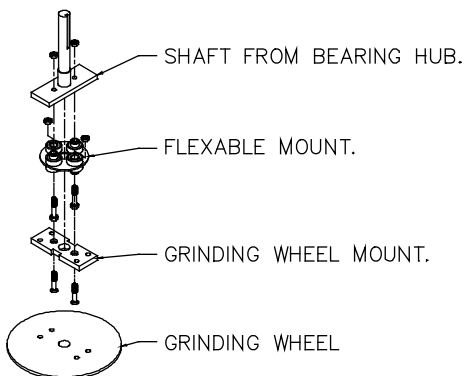

Item	Description	Qty	Part No.
A	Assembly, Accessory Pack		
A1	Grinding Wheels 10" (Reference only)	0	Reference
A2	Pallet (not shown)	1	158259
A3	Carton, SDG-11 Grinder (not shown)	1	158272
A4	Tube, Owner's Manual (not shown)	1	155419
A5	Manual, Owner's (not shown)	1	158273
A6	Bolt, Hex HD, 3/8-24 x 1 Grinding Disk, Mounting	4	157803
A7	Washer, 3/8 Split Lock	4	150925
A8	Washer, 3/8 SAE Flat	4	150923
B	Assembly, Frame		
B1	Frame Weldment	1	157780
B2	Plate, Serial Number	1	157500
B3	#7 X 5/16 Drive Screw	2	157849
B4	Tray, Weight	1	157785
B5	Screw, 5/16-18 x 3/4 Hex Head	2	151369
B6	Washer, 5/16 lock, split	2	151747
B7	Washer, 5/16 SAE Flat	2	151754
B8	Housing, Weight	1	157783
B9	Label, Caution, Belt Tension	2	155583
B10	Label, Caution, Guards in Place	1	155587
B11	Label, Caution, Hands and Feet	2	155585
B12	Label, Lower/Raise	1	158141
C	Assembly, Skirt		
C1	Skirt, Front	1	157817
C2	Skirt, Retainer	1	157819
C3	Skirt, Rear	1	157818
C4	Screw, 5/16-18 x 3/4 Hex Head	15	151369
C5	Washer, 5/16 lock, split	15	151747
C6	Washer, 5/16 SAE Flat	15	151754
D	Assembly, Weight Box		
D1	Box, Weight	1	157784
D2	Cap, Weight Box	1	157890
D3	Label, 1 3/4 x 5" MK Logo	1	154335
E	Assembly, Lifting Frame		
E1	Frame, Lifting	1	157781
E2	Screw, Flat HD SOC. 1/2-13 x 1"	2	157822
E3	Nut, Center Lock 1/2-13	2	153943
E4	Pedal, Lifting Frame	1	157782
E5	Bolt, 1/2-13 x 2 Hex Head	1	153533
E6	Washer, Lock, Split 1/2	1	153524
E7	Washer, Flat SAE 1/2	1	150924
E8	Spring, Lifting Frame	2	157821
E9	Wheel, 2" Caster (LA-E2-XD)	2	160455
E10	Washer, 5/16 lock, split	2	151747
E11	Nut, 5/16-18 Hex	2	101196
F	Assembly, Components, Hub		
F1	Hub, 1" Assembly (3 1/2 C)	1	157820
F2	Nut, Jam 1/2-20	4	154460

F3	Washer, Lock, Split 1/2	4	153524
F4	Washer, Flat SAE 1/2	4	150924
F5	Shaft, 1" Dia Large Gear	1	157302
F6	Flexible Mount, Morflex (Morse 402 Insert)	1	157411
F7	Mount, Grinding Wheel	1	157407
F8	Screw, Hex HD Cap 3/8-16 x 2 1/2	2	156030
F9	Screw, Flt. HD. Sc. 3/8-16 x 2 1/2	2	157562
F10	Nut, 3/8-16, Hex Nylock	4	152505
F11	Washer, 3/8 SAE Flat	4	150923
F12	Spacer, 1 1/4" OD, 1" I.D. x 1 3/8"	1	158257
F13	Key, Square, 1/4 x 1/4 x 1 1/2"	1	157560
F14	Pulley, 2G3V 6.9 SDS	1	160098
F15	QD x 1" SD (D1 reverse mount sheave bushing)	1	157899
G	Assembly, Engine, 11HP Honda		
G1	Engine, Honda GX340k2dx3	1	157067
G2	Pulley, 2G3V 2.20 JA	1	160099
G3	QD x 1" SH (sheave bushing)	1	157900
G4	Key, Square, 1/4 x 1/4 x 1 1/2"	1	157560
G5	Screw, 3/8-16 x 1 3/4" Hex Head Tap	1	158398
G6	Washer, 3/8 SAE Flat	1	150923
G7	Washer, 3/8 Split Lock	1	150925
G8	Nut, 3/8-16 Hex	1	101188
G9	Mount, 3/8-16 Swivel	1	158371
G10	Screw, 5/16-24 x 1" Hex Head	2	157646
G11	Screw, 5/16-18 x 1 3/4" Hex Head Cap	2	150919
G12	Washer, 5/16 SAE Flat	4	101352
G13	Washer, 5/16 Split Lock	4	151747
G14	Nut, 5/16-18 Hex	2	101196
G15	Hose, Oil Drain (20mm)	1	157577-04
G16	Belt, 3VX 375	2	157891
G17	Label, Caution, Hot Surface, 1.5 x 3.0	1	155578
G18	Label, Warning, Refueling, 1.5 x 3.0	1	155580
G19	Label, Danger, California, 1.5 x 3.0	1	155581
G20	Label, Danger, Lethal Exhaust, 1.5 x 3.0	1	155582
G21	Label, Caution, Sparkplug	1	155579
G22	Label, Control Panel (Gas)	1	157888
GB	Assembly, 115/230V, 3Hp Motor		
GD1	Motor, 3Hp 208-230V 60Hz 1725rpm	1	161179
GD2	Pulley, 3V/3V27 x 1-1/8 Bore	1	160625
GD3	Screw, Set, Cup Pt, 1/4-20 x 5/16	1	154226
GD4	Pulley, 3/3V50 x SDSQD	1	160193
GD5	Belt, 3VX355	3	160385
GD6	Screw, Hex Hd, 1/2-13 x 1-1/4	4	153532
GD7	Washer, Lock, Split, 1/2	4	153524
GD8	Washer, Flat, SAE, 1/2	4	150924
GD9	Screw, Hex Hd. Tap, 3/8-16 x 1-3/4	1	158398
GD10	Mount, 3/8-16 Swivel	1	158371
GD11	Pulley, 3/3V50 x SDSQD	1	160193
GD12	Nut, Hex, 1/2-13	4	151282
GD13	Lever, Actuator	1	159540
GD14	Bushing, Switch 30A	1	158799
GD15	Screw, Pan Hd, #6-32 x 5/8	4	157393
GD16	Cover, Switch Box, 30A	1	159539

GD17	Gasket, 30A Switch Box	1	159491
GD18	Seal, Level, 30A Switch Box	1	159492
GD19	Lever, On/Off, 30A Switch Box	1	159490
GD20	Washer, #10 SAE Flat	1	154369
GD21	Washer, Lock, IT, #10	1	158336
GD22	Screw, Pan Head #10-24 x 5/16	1	159494
GD23	Screw, Flat Head 6-32 X 5/16	6	159493
GD24	Switch, 30Amp Motor Controller	1	159488
GD25	Plate, Mounting, Switch	1	159489
GD26	Box, 30A Switch	1	159487
GD27	Connector, Cord LTF29	1	160689
GD28	Nut, MCFL, 1/2NPT	1	152729
GD29	Bracket, MK 212 Switch	1	159864
GD30	Screw, Pan Head Phillips 1/4-20 x 1/2	2	155452
GD31	Washer, Lock, Split, 1/4	2	152591
GD32	Screw, Hex Head Cap 5/16-18 x 3/4	2	151369
GD33	Washer, 5/16 Flat SAE	4	151754
GD34	Washer, 5/16 Split Lock	2	151747
GD35	Nut, 5/16-18 Hex	2	101196
GD36	Label, Control Panel, SDG Elect	1	160046
H	Assembly, Axle		
H1	Wheel, 10"Dia. x 2.5"	2	157889
H2	Cotter Pin, Steel Hairpin, 5/8" - 3/4" x .148" x 2 11/16"	2	158228
H3	Axle, 5/8" Dia.	1	157887
H4	Washer, 5/8 SAE Flat	4	158350
J	Assembly, Handlebar		
J1	Handlebar	1	157786
J2	Handgrip, .875 x 4.25 Neoprene	2	229413
J3	Screw, 3/8-16 X 2 Hex Head Cap	2	153485
J4	Washer, 3/8 SAE Flat	4	150923
J5	Nut, 3/8-16 Nylock Hex	2	152505
K	Assembly, Throttle, Honda		
K1	Screw, 10-24 X 1/2" Pan Head Phillips Cap	2	151744
K2	Nut, 10-24 Clip	2	155407
K3	Assembly, Throttle Head	1	155406
K4	Cable, Throttle, Honda	1	156640
L	Assembly, Water Valve		
L1	Fitting, Brass, 1/2 MNPT x Garden Hose Swivel	1	151322
L2	Valve, Shut-Off, 1/2 FNPT x 1/2 FNPT	1	150843
L3	Nut, 1/2 NPT	1	152729
L4	Fitting, Brass, 1/2 MNPT x 1/4 Compression Fit	1	157563
L5	Tube, 1/4 OD Water	2'	157564
L6	Clamp, 5/8 Hose	2	151198
L7	Hose, Water Vinyl 1/4 x 3/8	6'	132951

MK-1010/MK-1020 SERIES of grinding heads are designed to give rough concrete surfaces the smoothest finish in the quickest time. Available in either 10 or 20 segment configurations. Hard bond is for grinding green concrete and asphalt. Soft bond is for grinding cured concrete.



MK-1010H Premium Hard Bond Grinding Head

Diameter	Mount	Segments	Part#
10" (254 mm)	4 Bolt	10	158181

Segment Height: 8 mm

MK-1010S Premium Soft Bond Grinding Head

Diameter	Mount	Segments	Part#
10" (254 mm)	4 Bolt	10	151925

Segment Height: 8 mm



MK-1020H Premium Hard Bond Grinding Head

Diameter	Mount	Segments	Part#
10" (254 mm)	4 Bolt	20	158182

Segment Height: 8 mm

MK-1020S Premium Soft Bond Grinding Head

Diameter	Mount	Segments	Part#
10" (254 mm)	4 Bolt	20	151926

Segment Height: 8 mm



MK-1020 TURBO Supreme Hard Bond Grinding Head

Diameter	Mount	Segments	Part#
10" (254 mm)	4 Bolt	20	167939

Includes the mounting bolts



MK-1020 ARROW Supreme Soft Bond Grinding Head

Diameter	Mount	Segments	Part#
10" (254 mm)	4 Bolt	20	168446

Segment Height: 8 mm
Includes the mounting bolts

ORDERING INFORMATION

You may order MK Diamond products through your local MK Diamond distributor or, you may order direct from MK Diamond.

When ordering direct from MK Diamond, please have the following information ready before calling:

- The Model Number of the saw
- The Serial Number of the saw
- Where the saw was purchased and when
- The Part Number for the part(s) being ordered
- The Part Description for the part(s) being ordered

NOTE: There is a \$25.00 minimum order when ordering direct from MK Diamond. A \$5.00 charge will be added to orders having a net billing value under \$50.00. All purchases must be made using VISA, MasterCard or American Express.

All parts may be ordered by calling toll free to – 800 421-5830 or 310 539-5221 and asking for Customer Service. For technical questions, call – 800 474-5594.

RETURN MATERIALS POLICY

To expedite the service relative to the return of a product purchased through MK Diamond, please observe the following:

NOTE: When returning all items, they must have been purchased within the previous twelve (12) months.

- Have the Model Number of the saw
- Have the Serial Number of the saw
- Have the location of where the saw was purchased
- Have the date when the saw was purchased
- Contact Customer Service for approval to return the item(s)
- Obtain a Returned Goods Number (RGA) authorizing the return
- Follow the packaging instructions in the following section
- Ensure your item(s) are prepaid to the destination

For returned items, call toll free to – 800 421-5830 or 310 539-5221 and ask for Customer Service. For technical questions, call – 800 474-5594 or 310 257-2845.

PACKAGING INSTRUCTIONS

- Remove the Cutting Head and Support Angle Assembly
- Dry the saw before shipping
- When packing, include the following: Saw, Diamond Blade, Blade Guard and Support Angle Assembly and Adjustable Cutting Guide (Other Accessories are not required)
- Package the unit in its original container or one of comparable size (do not ship the unit partially exposed)
- Ensure all parts are secured in the packaging to prevent moving

AUTHORIZED SERVICE CENTERS

For quicker repair time, you may contact MK Diamond Customer Service, toll free, at 800 421-5830 or 310 539-5221 for the Authorized Service Center closest to you or visit our web site at www.mkdiamond.com. For technical questions, call – 800 474-5594.

CONTACT:

Please contact MK Diamond Products, Inc. Customer Service Department with any questions you might have regarding distributors, parts or service.

Telephone: **(800) 421-5830**

Fax: **(310) 539-5158**

E-mail: **Customer_Service@MKDiamond.com**

Customer Service Hours: **Monday through Friday, 6AM-4PM PST**

MK Diamond Products, Inc.

1315 Storm Parkway

Torrance, CA 90501

MK DIAMOND PRODUCTS, INC. LIMITED WARRANTY

MK DIAMOND PRODUCTS, INC. will guarantee every machine they build, to be free from defects in material and workmanship for (1) one year from date of purchase. The obligation of MK DIAMOND PRODUCTS, INC. under this warranty is limited to the repair or replacement of any parts which, under normal use, prove to be defective in material or workmanship. The parts involved or the unit in question should be returned to MK DIAMOND PRODUCTS, INC. or to a point designated by us, transportation prepaid.

This warranty does not obligate us to bear the cost of labor or transportation charges in connection with replacement or repair of defective parts. Likewise, it shall NOT apply to any unit which has been subjected to misuse, neglect or accident. This warranty does NOT apply to any machine which has been repaired or altered outside our factory.

This warranty does NOT obligate MK DIAMOND PRODUCTS, INC., with respect to items not of our manufacture, such as engines, motors, hydraulics, etc., which are subject to their own guarantees and warranties.

We shall in no event be liable for consequential damages or contingent liabilities arising out of failure of any equipment or parts to operate properly.

© COPYRIGHT 2011, MK DIAMOND PRODUCTS, INC. ALL RIGHTS RESERVED.

The MK Diamond logo is a registered trademark of MK Diamond Products, Inc. and may not be used, reproduced, or altered without written permission. All other trademarks are the property of their respective owners and used with permission.

MK Diamond may have patents, patent applications, trade marks, copyrights of other intellectual property right covering this product in this document.

This manual MUST accompany the equipment at all times. This manual is considered a permanent part of the equipment and should remain with the unit if resold.

The information and specifications included in this publication were in effect at the time of approval for printing.

MK- SINGLE DISC GRINDER
OWNERS MANUAL, PARTS LIST &
OPERATING INSTRUCTIONS



MK Diamond Products, Inc.

MK Diamond Products, Inc.
1315 Storm Parkway
Torrance, CA 90501

Toll-Free: (800) 421-5830
Phone: (310) 539-5221
Fax: (310) 539-5158
www.mkdiamond.com