

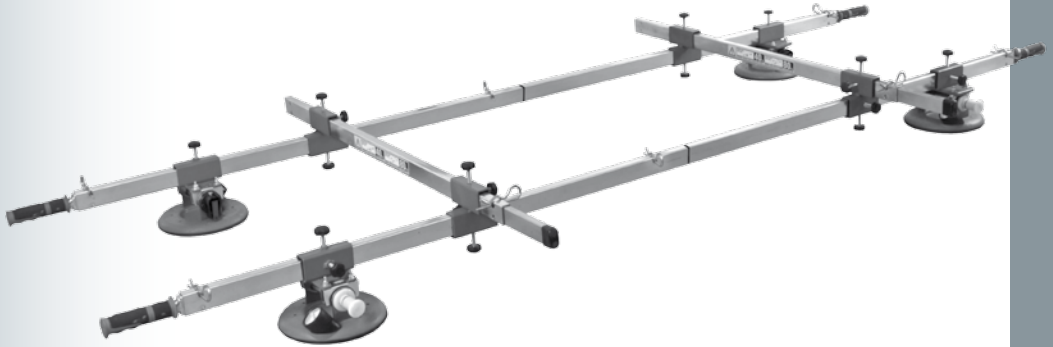





# PROGETTO 300 SUPERSTICK

SINCE 1946



## Art. 300-70

-  SISTEMA MODULARE DI MOVIMENTAZIONE LASTRE - KIT COMPLETO
-  MODULAR SYSTEM OF HANDLING OF SLABS - FULL KIT
-  SYSTÈME MODULAIRE DE MANIPULATION DES GRANDS CARREAUX - KIT COMPLET
-  HANDHABUNG BAUKASTEN DER GROSSE FLIESEN - KOMPLETT-SET



32 Kg



100% MADE IN ITALY



VIETATA LA MOVIMENTAZIONE CON MEZZI DI SOLLEVAMENTO  
NOT FOR MOVEMENT WITH LIFTING EQUIPMENT  
PAS DE MOUVEMENT AVEC EQUIPEMENT DE LEVAGE  
NICHT ZUR BEWEGUNG MIT LIFTING AUSTRÜSTUNG

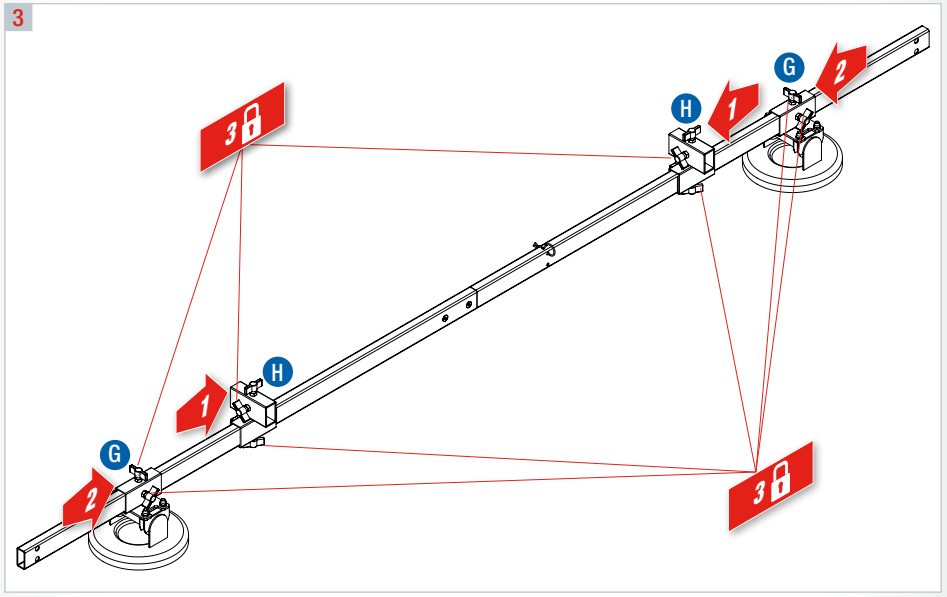
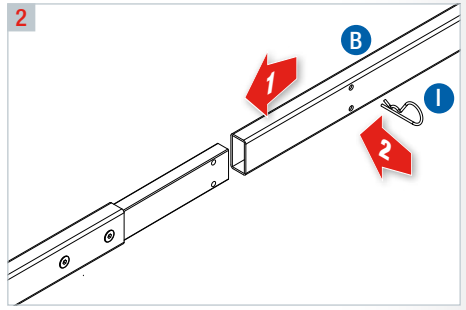
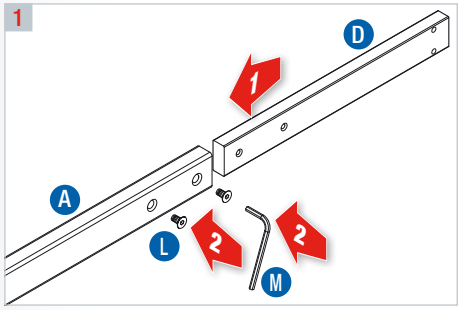
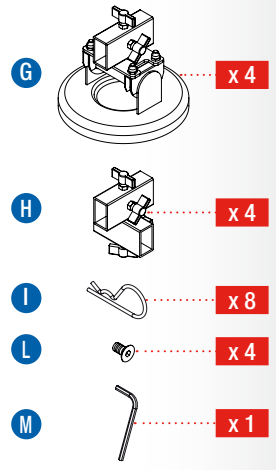
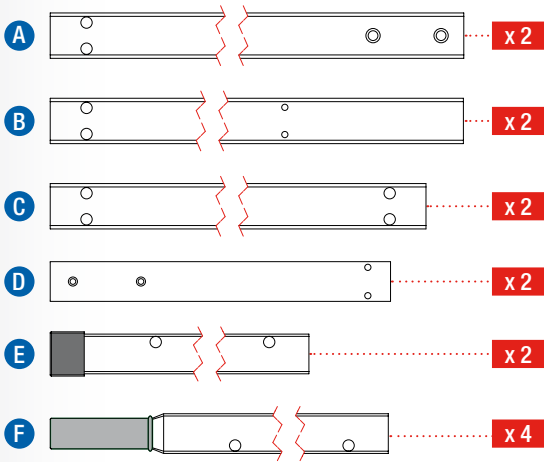

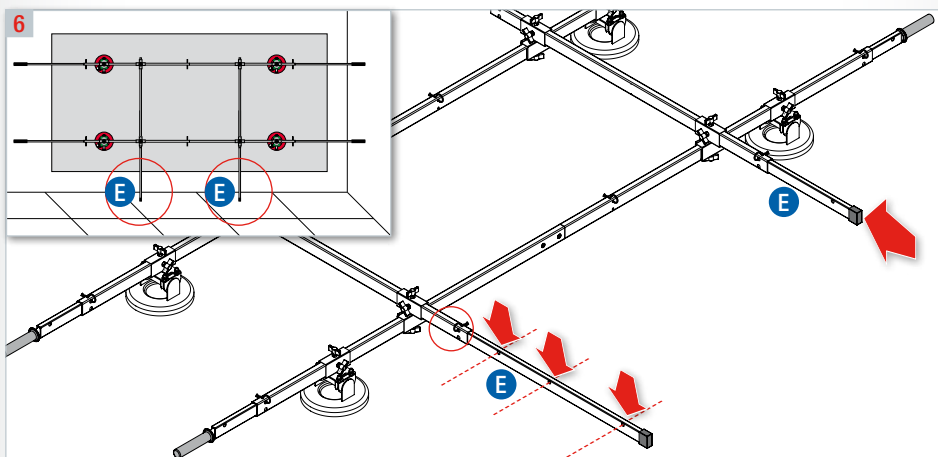
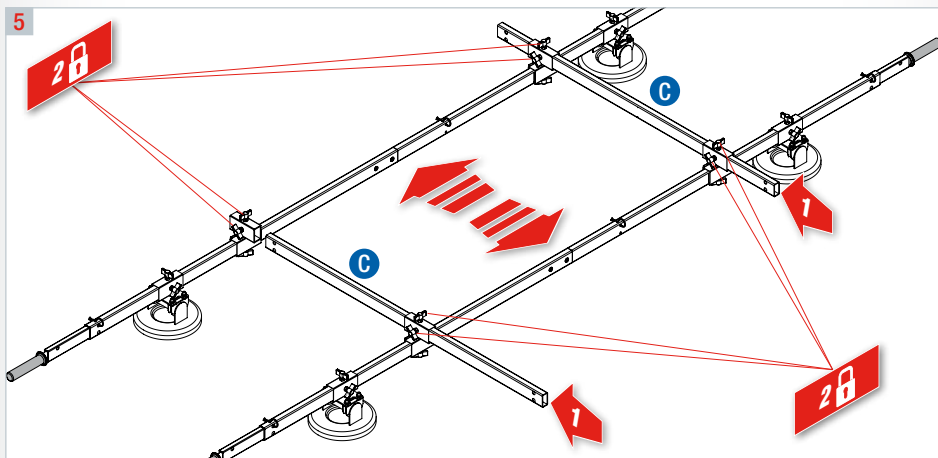
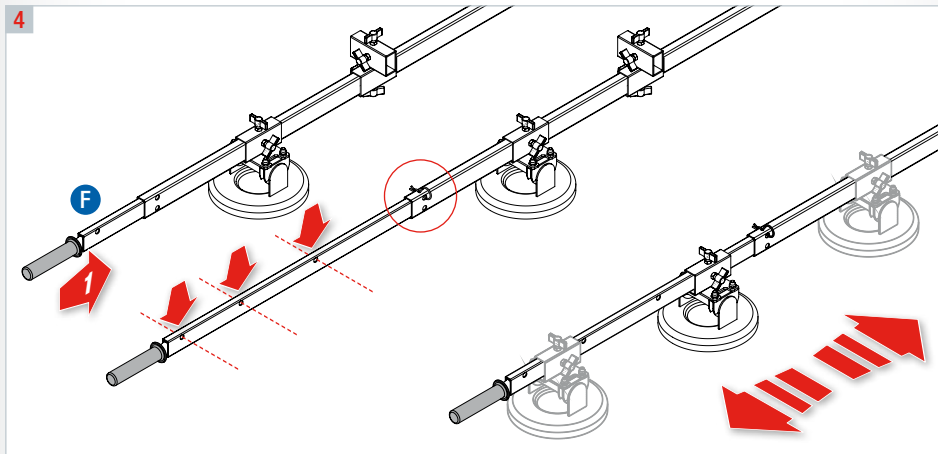

7

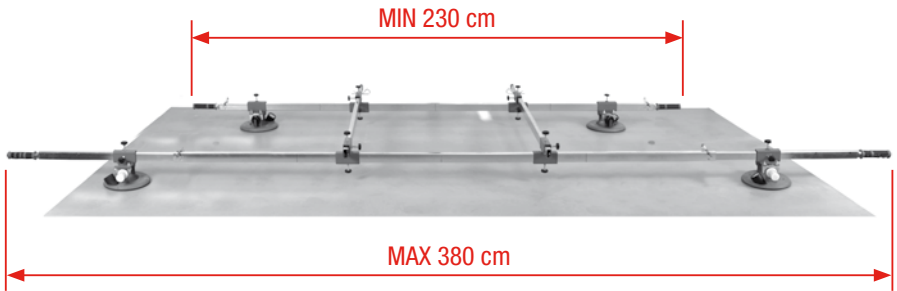

8

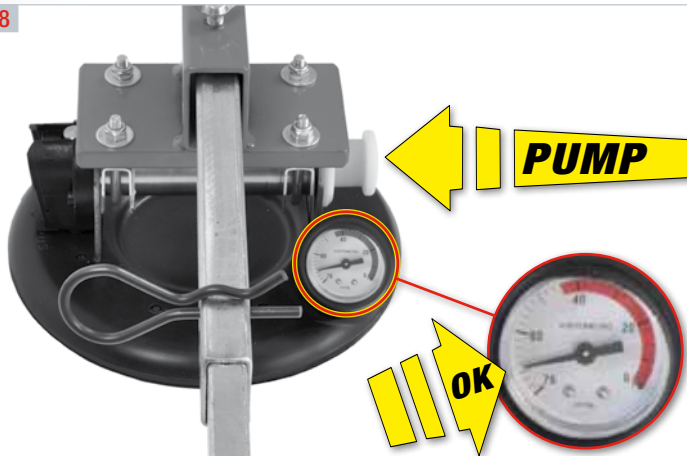
**MAX LOAD****80** Kg

**ATTENZIONE:**  
controllare sem-  
pre l'integrità del-  
le ventose.

**WARNING:**  
always check the  
condition of the  
suction cups.

**ATTENTION:**  
Toujours vérifier  
l'état des ven-  
touses.





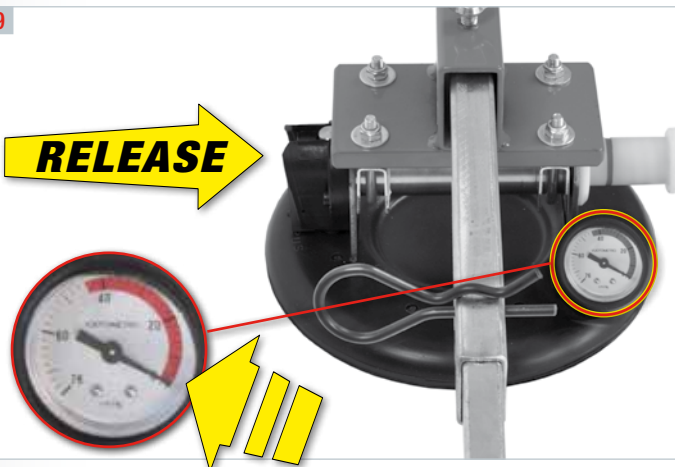

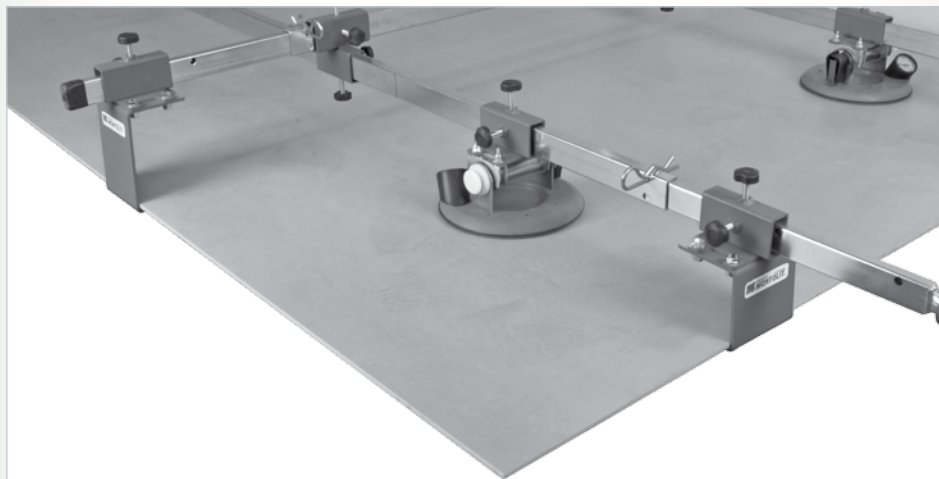
**WARNUNG:**  
Stets den Zustand  
der Saugnäpfe  
kontrollieren.

9











## Optional · Art. 300-77

- 

**SISTEMA DI SICUREZZA  
PER LASTRE CORRUGATE**
- 
**EXTRA SAFETY HOOKS  
FOR ROUGH SLABS**
- 

**CROCHETS DE SÉCURITÉ SUPPLÉMENTAIRES  
POUR LES CARREAUX RUGUEUSES**
- 
**SUPPORT FÜR STRUKTURIERTE  
OBERFLÄCHEN**

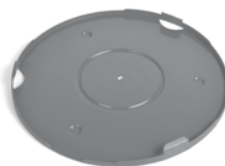

## Optional · Art. 300-76C

- 

**PROTEZIONE PER VENTOSA**
- 
**PROTECTION FOR SUCTION CUP**
- 

**PROTECTION POUR VENTOUSE**
- 
**SCHUTZ FÜR SAUGNAPFS**



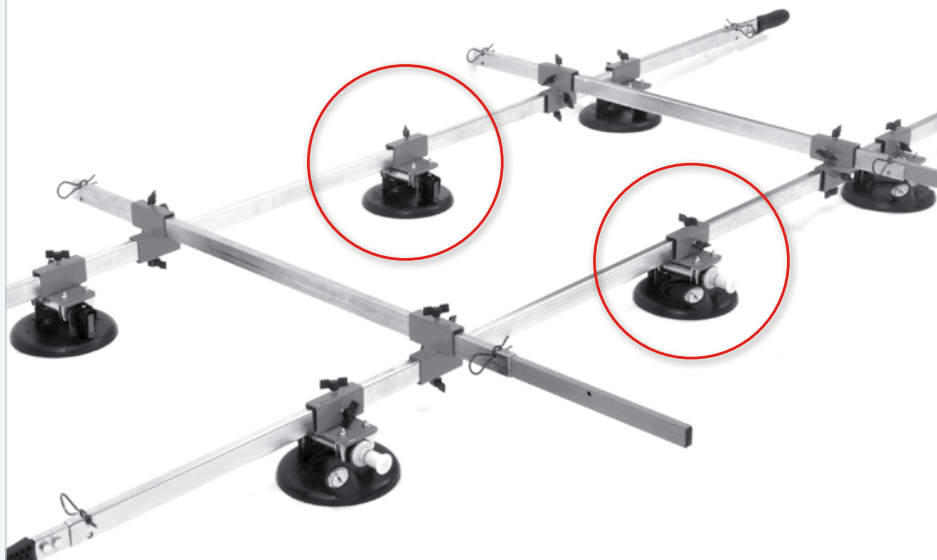

## Optional · Art. 300-71

-  **VENTOSA EXTRA**
-  **EXTRA SUCTION CUP**
-  **EXTRA VENTOUSE**
-  **EXTRA SAUGNAPF**



 **GARANZIA** - Tutte le attrezzature manuali MONTOLIT sono coperte da garanzia a vita (riconosciuta a giudizio esclusivo dell'Ufficio Tecnico della Brevetti MONTOLIT S.p.A.) su eventuali difetti di costruzione. Guasti derivanti da un uso non conforme o da normale usura sono esclusi dalla presente garanzia.

 **WARRANTY** - All MONTOLIT manual equipment are covered by lifetime warranty (recognisable exclusively by the MONTOLIT S.p.A. Patents Technical Office) on any manufacturing defects. Breakages resulting from non-conforming or abnormal use are excluded from cover by this warranty.

 **GARANTIE** - Tous les équipements manuels MONTOLIT sont couverts par une garantie à vie (reconnue par le service technique Brevetti MONTOLIT S.p.A.) contre les défauts de construction. Les problèmes dérivant d'une utilisation non conforme ou de l'usure normale sont exclus de la présente garantie.

 **GARANTIE** - Alle Ausrüstung MONTOLIT sind auf unbeschränkte Dauer gegen eventuelle Konstruktionsfehler garantiert (maßgebend ist diesbezüglich ausschließlich das Urteil des Technischen Büros der Firma Brevetti MONTOLIT S.p.A.). Beschädigungen infolge unsachgerechter Verwendung oder normalem Verschleiß werden nicht von dieser Garantie gedeckt.

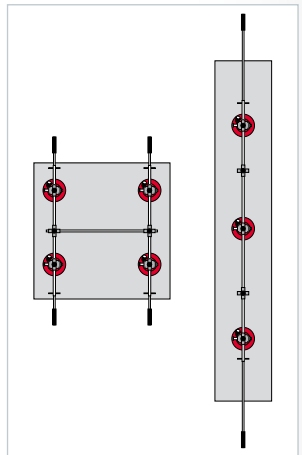
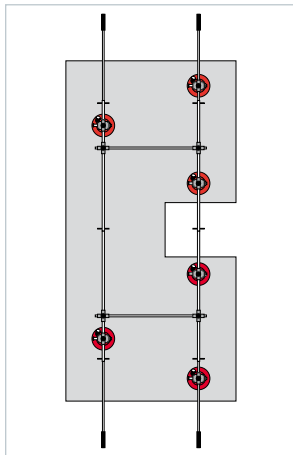
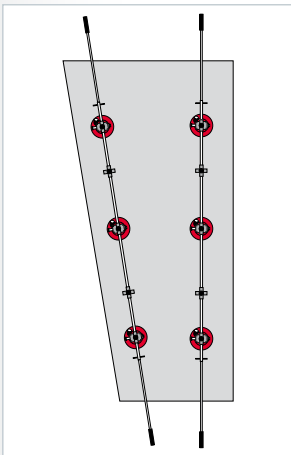
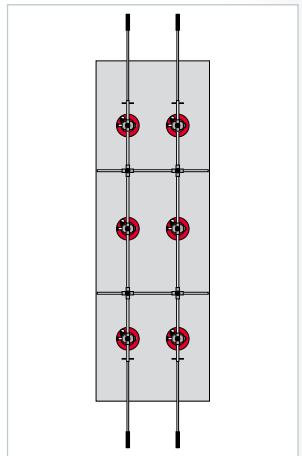
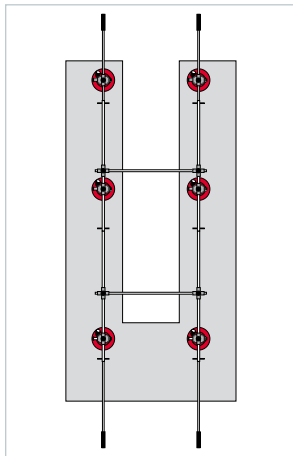
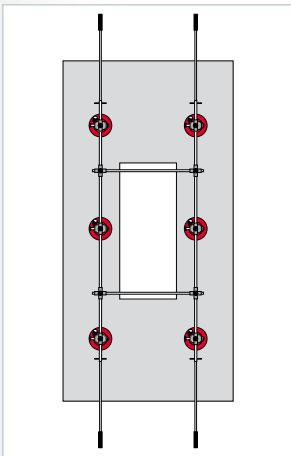
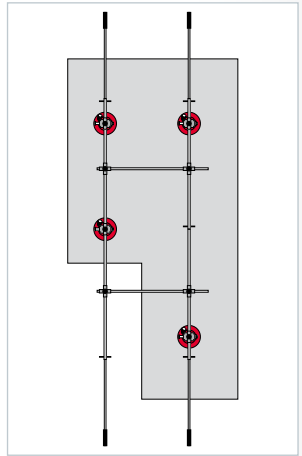
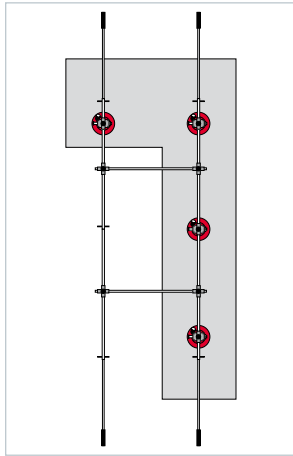
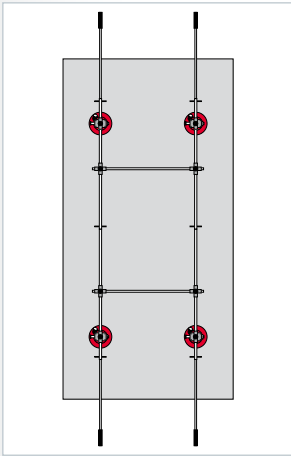



SINCE 1946

## **Brevetti Montolit S.p.A.**

*Sedi operative/ Company headquarters:*

Largo Cav. Montoli - 21050 Cantello (VA) Italy

Via Varese 4/A - 21050 Cantello (VA) Italy

*Sede legale/Legal head office:*

Via Turconi, 25 - 21050 Cantello (VA) Italy

Tel. ++39 0332 419 211

Fax ++39 0332 418 444

[www.montolit.com](http://www.montolit.com) - [info@montolit.com](mailto:info@montolit.com)