

OPERATION AND PARTS MANUAL



MODELS
MQ600H
MQ600HTB
MQ600HTP
TRASH PUMP
(HATZ 4H50TIC DIESEL ENGINE)

Revision #2 (04/10/20)

To find the latest revision of this
publication, visit our website at:
www.multiquip.com



THIS MANUAL MUST ACCOMPANY THE EQUIPMENT AT ALL TIMES.

PROPOSITION 65 WARNING



REPORTING SAFETY DEFECTS

If you believe that your vehicle has a defect that could cause a crash or could cause injury or death, you should immediately inform the National Highway Traffic Safety Administration (NHTSA) in addition to notifying Multiquip Inc. at 1-800-421-1244.

If NHTSA receives similar complaints, it may open an investigation, and if it finds that a safety defect exists in a group of vehicles, it may order a recall and remedy campaign. However, NHTSA cannot become involved in individual problems between you, your dealer, or Multiquip Inc.

To contact NHTSA, you may either call the Vehicle Safety Hotline toll-free at 1-888-327-4236 (TTY: 1-800-424-9153), go to <http://www.safercar.gov>, or write to:

Administrator
NHTSA
1200 New Jersey Avenue, SE
Washington, DC 20590

You can also obtain information about motor vehicle safety from <http://www.safercar.gov>.

TABLE OF CONTENTS

MQ600H-HTB-HTP Trash Pump

Proposition 65 Warning	2
Reporting Safety Defects.....	3
Table of Contents.....	4
Training Checklist	6
Daily Pre-Operation Checklist	7
Safety Information	8–12
Specifications	13
Dimensions.....	14–15
General Information.....	16
Line Configuration/Layout.....	17
Components	18–19
Basic Engine.....	20
Application	21
Setup	22–24
Startup.....	25–31
Operation.....	32
Maintenance	33–40
Towing Guidelines	41
Trailer Guidelines.....	42–56
Troubleshooting	57–60
Explanation of Code in Remarks Column.....	62
Suggested Spare Parts	63

Component Drawings

Nameplate and Decals	64–65
Impeller, Cleanout, and Discharge Assembly..	66–67
Pump — Suction Side Assembly.....	68–69
Intermediate Plate Assembly.....	70–71
Trailer Assembly	72–73
Engine Mounting Assembly	74–75
Battery/Engine Cover Assembly.....	76–77
Air Filter Assembly.....	78–79
Control Box Assembly	80–81
Hydraulic Brake Line Assembly.....	82–83
Hatz 4H50TIC Engine Service Parts.....	84–85

NOTICE

Specifications and part numbers are subject to change without notice.

TRAINING CHECKLIST

Training Checklist			
No,	Description	OK?	Date
1	Read operation manual completely.		
2	Machine layout, location of components, checking of engine.		
3	Fuel system, refueling procedure.		
4	Operation of controls (machine not running).		
5	Ignition switch operation.		
6	Emergency stop procedures.		
7	Startup of machine, pre-heat.		
8	Shutdown of machine.		
9	Lifting of machine (lifting bale).		
10	Machine transport and storage.		

DAILY PRE-OPERATION CHECKLIST

Daily Pre-Operation Checklist		✓	✓	✓	✓	✓	✓
1	Hardware and damage check						
2	Engine oil level						
3	Braking control operation						
4	Bearing sight glass oil level						
5	Mechanical seal, check sight glass oil						

SAFETY INFORMATION

Do not operate or service the equipment before reading the entire manual. Safety precautions should be followed at all times when operating this equipment. Failure to read and understand the safety messages and operating instructions could result in injury to yourself and others.



SAFETY MESSAGES

The four safety messages shown below will inform you about potential hazards that could injure you or others. The safety messages specifically address the level of exposure to the operator and are preceded by one of four words: **DANGER**, **WARNING**, **CAUTION** or **NOTICE**.

SAFETY SYMBOLS

! DANGER

Indicates a hazardous situation which, if not avoided, **WILL** result in **DEATH** or **SERIOUS INJURY**.

! WARNING

Indicates a hazardous situation which, if not avoided, **COULD** result in **DEATH** or **SERIOUS INJURY**.







! CAUTION

Indicates a hazardous situation which, if not avoided, **COULD** result in **MINOR** or **MODERATE INJURY**.

NOTICE

Addresses practices not related to personal injury.

Potential hazards associated with the operation of this equipment will be referenced with hazard symbols which may appear throughout this manual in conjunction with safety messages.

Symbol	Safety Hazard
	Lethal exhaust gas hazards
	Explosive fuel hazards
	Burn hazards
	Respiratory hazards
	Accidental starting hazards
	Eye and hearing hazards

SAFETY INFORMATION

GENERAL SAFETY

CAUTION

- **NEVER** operate this equipment without proper protective clothing, shatterproof glasses, respiratory protection, hearing protection, steel-toed boots and other protective devices required by the job or city and state regulations.



- **NEVER** operate this equipment when not feeling well due to fatigue, illness or when under medication.



- **NEVER** operate this equipment under the influence of drugs or alcohol.



NOTICE

- This equipment should only be operated by trained and qualified personnel 18 years of age and older.
- Whenever necessary, replace nameplate, operation and safety decals when they become difficult read.
- Manufacturer does not assume responsibility for any accident due to equipment modifications. Unauthorized equipment modification will void all warranties.
- **NEVER** use accessories or attachments that are not recommended by Multiquip for this equipment. Damage to the equipment and/or injury to user may result.
- **ALWAYS** know the location of the nearest **fire extinguisher**.
- **ALWAYS** know the location of the nearest **first aid kit**.
- **ALWAYS** know the location of the nearest phone or **keep a phone on the job site**. Also, know the phone numbers of the nearest **ambulance, doctor** and **fire department**. This information will be invaluable in the case of an emergency.



PUMP SAFETY

DANGER

- **NEVER** pump volatile, explosive, flammable or low flash point fluids. These fluids could ignite or explode.
- The engine fuel exhaust gases contain poisonous carbon monoxide. This gas is colorless and odorless, and can cause death if inhaled.
- The engine of this equipment requires an adequate free flow of cooling air. **NEVER** operate this equipment in any enclosed or narrow area where free flow of the air is restricted. If the air flow is restricted it will cause injury to people and property and serious damage to the equipment or engine.



- **NEVER** operate the equipment in an explosive atmosphere or near combustible materials. An explosion or fire could result causing severe **bodily harm or even death**.



WARNING

- **NEVER** pump corrosive chemicals or water containing toxic substances. These fluids could create serious health and environmental hazards. Contact local authorities for assistance.
- **NEVER** open the priming plug when pump is hot. Hot water inside could be pressurized much like the radiator of an automobile. Allow pump to cool to the touch before loosening plug. The possibility exists of scalding, resulting in severe bodily harm.
- **NEVER** operate the pump with closed discharge hose. The liquid could reach boiling temperatures, build pressure, and cause the casing to rupture or explode.
- **NEVER** disconnect any **emergency or safety devices**. These devices are intended for operator safety. Disconnection of these devices can cause severe injury, bodily harm or even death. Disconnection of any of these devices will void all warranties.



SAFETY INFORMATION

CAUTION

- **NEVER** lubricate components or attempt service on a running machine.
- **NEVER** block or restrict flow from discharge hose. Remove kinks from discharge line before starting pump. Operation with a blocked discharge line can cause water inside pump to overheat.

NOTICE

- **ALWAYS** fill the pump casing with water before starting the engine. Failure to maintain water inside the pump housing will cause severe damage to the pump and mechanical seal.
- In winter drain water from pump housing to prevent freezing.
- **NEVER** start the pump with the clean-out cover removed. The rotating impeller inside the pump can cut or sever objects caught in it. Before starting the pump, check that the clean-out cover is securely fastened.
- **ALWAYS** keep the machine in proper running condition.
- **ALWAYS** ensure pump is on level ground before use.
- Fix damage to machine and replace any broken parts immediately.
- **ALWAYS** store equipment properly when it is not being used. Equipment should be stored in a clean, dry location out of the reach of children and unauthorized personnel.

ENGINE SAFETY

WARNING

- **DO NOT** place hands or fingers inside engine compartment when engine is running.
- **NEVER** operate the engine with heat shields or guards removed.
- **DO NOT** remove the engine oil drain plug while the engine is hot. Hot oil will gush out of the oil tank and severely scald any persons in the general area of the pump.



CAUTION

- **NEVER** touch the hot exhaust manifold, muffler or cylinder. Allow these parts to cool before servicing equipment.



NOTICE

- **NEVER** run engine without an air filter or with a dirty air filter. Severe engine damage may occur. Service air filter frequently to prevent engine malfunction.
- **NEVER** tamper with the factory settings of the engine or engine governor. Damage to the engine or equipment can result if operating in speed ranges above the maximum allowable.



FUEL SAFETY

DANGER

- **DO NOT** start the engine near spilled fuel or combustible fluids. Fuel is extremely flammable and its vapors can cause an explosion if ignited.
- **ALWAYS** refuel in a well-ventilated area, away from sparks and open flames.
- **ALWAYS** use extreme caution when working with flammable liquids.
- **DO NOT** fill the fuel tank while the engine is running or hot.
- **DO NOT** overfill tank, since spilled fuel could ignite if it comes into contact with hot engine parts or sparks from the ignition system.
- Store fuel in appropriate containers, in well-ventilated areas and away from sparks and flames.
- **NEVER** use fuel as a cleaning agent.
- **DO NOT** smoke around or near the equipment. Fire or explosion could result from fuel vapors or if fuel is spilled on a hot engine.



SAFETY INFORMATION

BATTERY SAFETY (ELECTRIC START ONLY)

DANGER

- **DO NOT** drop the battery. There is a possibility that the battery will explode.
- **DO NOT** expose the battery to open flames, sparks, cigarettes, etc. The battery contains combustible gases and liquids. If these gases and liquids come into contact with a flame or spark, an explosion could occur.



WARNING

- **ALWAYS** wear safety glasses when handling the battery to avoid eye irritation. The battery contains acids that can cause injury to the eyes and skin.
- Use well-insulated gloves when picking up the battery.
- **ALWAYS** keep the battery charged. If the battery is not charged, combustible gas will build up.
- **DO NOT** charge battery if frozen. Battery can explode. When frozen, warm the battery to at least 61°F (16°C).
- **ALWAYS** recharge the battery in a well-ventilated environment to avoid the risk of a dangerous concentration of combustible gases.
- If the battery liquid (dilute sulfuric acid) comes into contact with **clothing or skin**, rinse skin or clothing immediately with plenty of water.
- If the battery liquid (dilute sulfuric acid) comes into contact with **eyes**, rinse eyes immediately with plenty of water and contact the nearest doctor or hospital to seek medical attention.

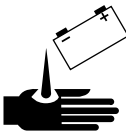

CAUTION

- **ALWAYS** disconnect the **NEGATIVE** battery terminal before performing service on the equipment.
- **ALWAYS** keep battery cables in good working condition. Repair or replace all worn cables.

TRANSPORTING SAFETY

CAUTION

- **NEVER** allow any person or animal to stand underneath the equipment while lifting.

NOTICE

- Before lifting, make sure that the equipment parts are not damaged and screws are not loose or missing.
- **ALWAYS** make sure forklift forks are inserted into pockets (if applicable) as far as possible when lifting the pump.
- **ALWAYS** shutdown engine before transporting.
- **NEVER** lift the equipment while the engine is running.
- Tighten fuel tank cap securely and close fuel cock to prevent fuel from spilling.
- Use one point suspension hook and lift straight upwards.
- **DO NOT** lift machine to unnecessary heights.
- **ALWAYS** tie down equipment during transport by securing the equipment with rope.
- Never allow any person or animal to stand underneath the equipment while lifting.

SAFETY INFORMATION

TOWING SAFETY

CAUTION

- Check with your local county or state safety towing regulations, in addition to meeting **Department of Transportation (DOT) Safety Towing Regulations**, before towing your generator. 
- Refer to MQ Power trailer manual for additional safety information.
- In order to reduce the possibility of an accident while transporting the generator on public roads, **ALWAYS** make sure the trailer that supports the generator and the towing vehicle are mechanically sound and in good operating condition.
- **ALWAYS** shutdown engine before transporting
- Make sure the hitch and coupling of the towing vehicle are rated equal to, or greater than the trailer “gross vehicle weight rating.”
- **ALWAYS** inspect the hitch and coupling for wear. **NEVER** tow a trailer with defective hitches, couplings, chains, etc.
- Check the tire air pressure on both towing vehicle and trailer. **Trailer tires should be inflated to 50 psi cold.** Also check the tire tread wear on both vehicles.
- **ALWAYS** make sure the trailer is equipped with a **safety chain**.
- **ALWAYS** properly attach trailer’s safety chains to towing vehicle.
- **ALWAYS** make sure the vehicle and trailer directional, backup, brake and trailer lights are connected and working properly.
- DOT Requirements (if applicable) include the following:
 - Connect and test electric brake operation.
 - Secure portable power cables in cable tray with tie wraps.
- The maximum speed for highway towing is **55 MPH** unless posted otherwise. Recommended off-road towing is not to exceed **15 MPH** or less depending on type of terrain.

- Avoid sudden stops and starts. This can cause skidding, or jack-knifing. Smooth, gradual starts and stops will improve towing.
- Avoid sharp turns to prevent rolling.
- Trailer should be adjusted to a level position at all times when towing.
- Raise and lock trailer wheel stand in up position when towing.
- Place **chock blocks** underneath wheel to prevent **rolling** while parked.
- Place **support blocks** underneath the trailer’s bumper to prevent **tipping** while parked.
- Use the trailer’s swivel jack to adjust the trailer height to a level position while parked.

ENVIRONMENTAL SAFETY

NOTICE

- Dispose of hazardous waste properly. Examples of potentially hazardous waste are used motor oil, fuel and fuel filters. 
- **DO NOT** use food or plastic containers to dispose of hazardous waste.
- **DO NOT** pour waste, oil or fuel directly onto the ground, down a drain or into any water source.

SPECIFICATIONS

Table 1. Pump Specifications

Maximum Pumping Capacity	1,600 gpm (6,055 lpm)
Maximum Suction Lift*	25 ft. (7.6 meters)
Maximum Total Head	150 ft. (45.7 meters)
Maximum Pressure	64.9 psi
Maximum Solids	3 in. (76 mm)
Suction and Discharge Diameter	6 in. (152 mm)
Pump Dimensions (Skid) LxWxH	82.8 X 38.4 X 54.1 in. (2,103.1 X 975.4 X 1,374.1 mm)
Pump Dimensions (Trailer) LxWxH	125 X 63.5 X 69.6 in. (3,175 X 1,612.9 X 1,767.8 mm)
Fuel Tank Capacity (Skid/Trailer)	40 gal (151 liters)
Weight (Trailer Mounted - No Fuel)	2,850 lbs. (1,283 kg.)
* Based on pump operating at sea level. Maximum suction lift will be less at higher altitudes.	

Table 2. Engine Specifications

Engine Make	Hatz
Engine Model	4H50TIC
Engine Type	Direct injection, turbocharger with charge air cooling
Exhaust Emission After-Treatment	EGR, DOC
Number Of Cylinders	4
Bore/Stroke	3.3/3.5 in (84/88 mm)
Displacement	119 in ³ (1,952 cc)
Horse Power (HP)	68.4 (50.3 kW) @ 2,000 RPM
Oil Capacity	7.4 quarts (7.0 liters)
Oil Pressure	2.5 to 4.5 bar
Fuel Type	Diesel (Low Sulphur)
Fuel Tank Capacity (Trailer)	40 gal (151 liters)
Starting Method	Electric Start
Battery	12 V – 110 Ah / 450 A according to DIN 24 V – 66 Ah / 300 A according to DIN

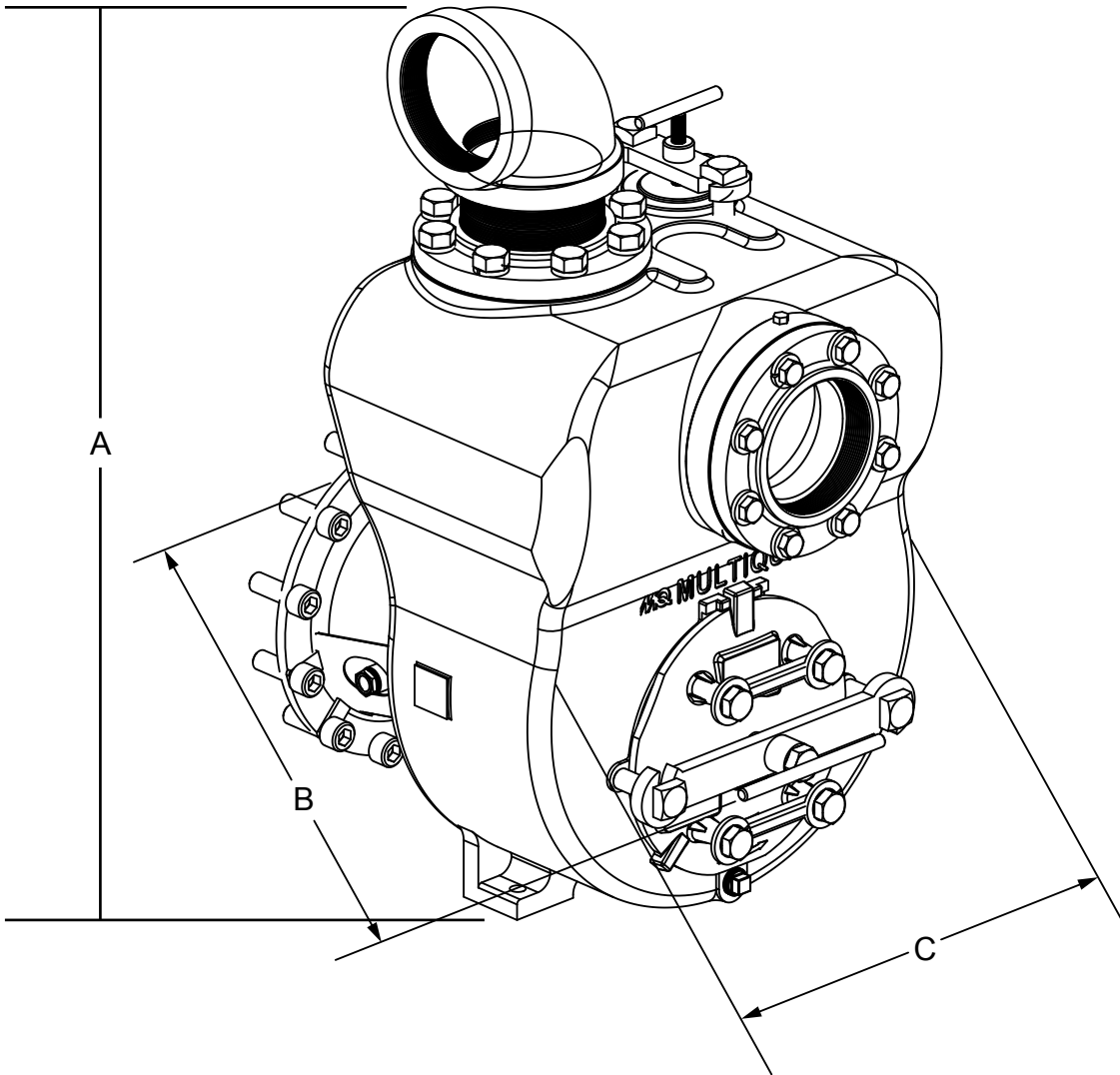

Figure 1. Pump Dimensions

Table 3. Pump Dimensions		
REFERENCE LETTER	DESCRIPTION	DIMENSIONS INCHES (MM)
A	MEASURED FROM TOP OF 90 DEGREE ELBOW TO MOUNTING FEET (HEIGHT)	45.5 (1,156)
B	MEASURED FROM TIP OF INTERMEDIATE HOUSING TO TIP OF LOCKING HANDLE (DEPTH)	32 (813)
C	MEASURED FROM PUMP SIDE-WALL TO SIDE-WALL (WIDTH)	24.5 (622)

DIMENSIONS

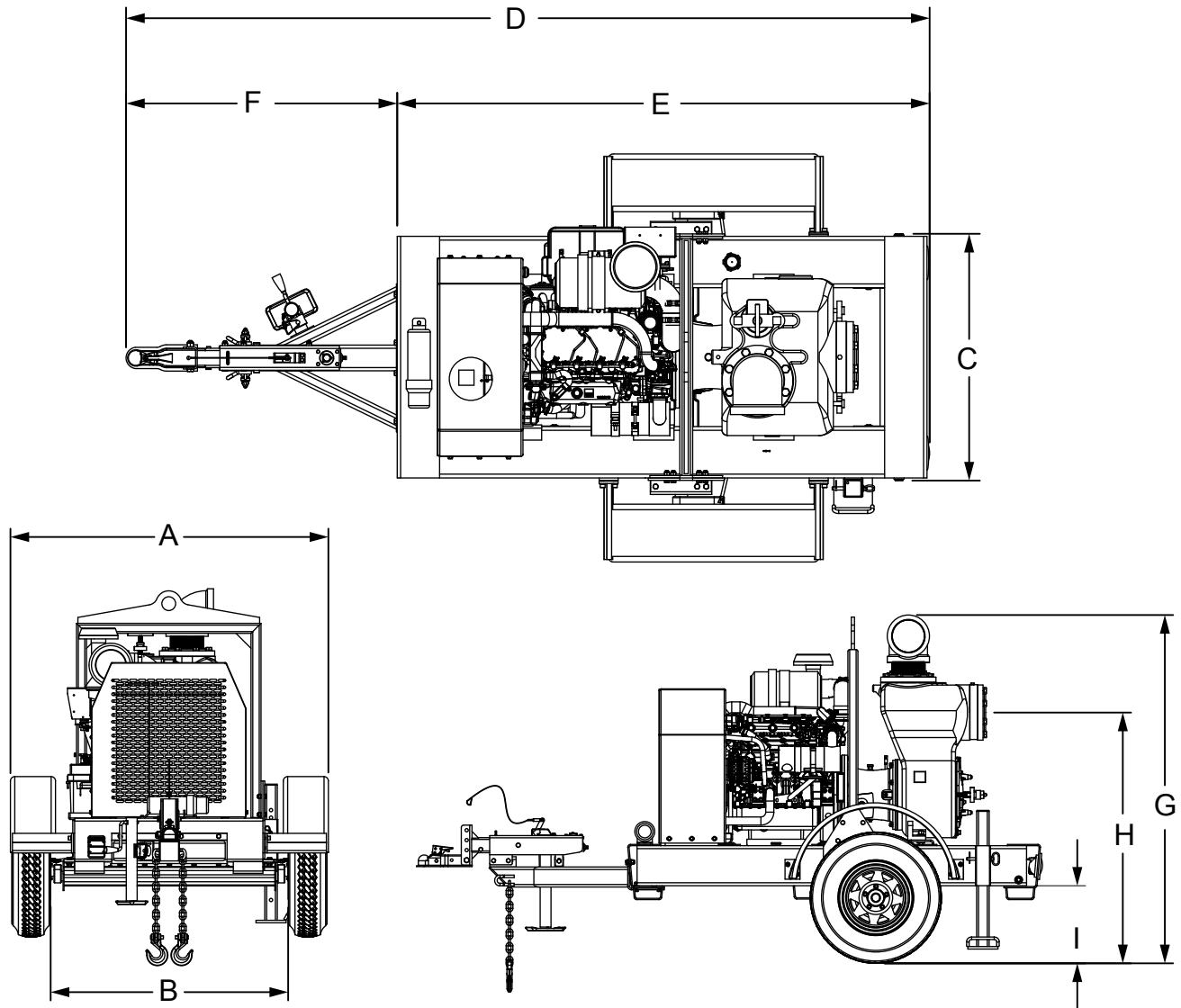

Figure 2. Trailer Dimensions

Table 4. Trailer Dimensions	
REFERENCE LETTER	DIMENSIONS INCHES (MM)
A	63.5 (1,613)
B	47.4 (1,205)
C	38.4 (975.5)
D	125 (3,175.5)
E	82.8 (2,103.9)
F	42.2 (1,071.6)
G	69.6 (1,767.3)
H	50.1 (1,272.4)
I	15.5 (393.7)

GENERAL INFORMATION

The MQ600H-HTB-HTP Trash Pump is a self-priming centrifugal trash pump powered by a 74.5 horsepower Hatz diesel engine. Both the intake (suction) and discharge ports on the MQ600H-HTB-HTP incorporate a 6-inch diameter opening, which allows the pump to perform at a rate of approximately 1,600 gpm or 6,055 lpm.

This is a self-priming pump design and the pump casing must be filled with water before starting operation. The engine drives a rotating disc with two (or more) vanes called an impeller that creates an area of low pressure inside the pump. Priming is accomplished when all air is purged from the pump and suction line allowing water to flow continuously into the pump.

TRASH PUMP

Trash pumps derive their name from their ability to handle a greater amount of debris and solids than standard centrifugal pumps. These pumps generally handle solids up to 1/2 the size of the discharge opening making them less likely to clog. Also, trash pumps are capable of handling water with 25% solids by weight.

The advantage of using a trash pump is that it can be quickly and easily disassembled in the field to remove debris in the event the pump becomes clogged.

SUCTION LIFT

This pump has a maximum suction lifts up to 25 feet at sea level. **At elevations above sea level suction lift decreases at a rate of 1 foot of suction lift per 1,000 feet of elevation.** Therefore, when this pump is being used at an elevation of 5,000 feet, the maximum suction lift is reduced to 20 feet. It is recommended that the pump be located as close to the source as possible to minimize suction lift.

PUMP SUPPORT

The pump should always be placed on solid stationary ground in a level position. To prevent the trailer from tipping, place blocks under the trailer's bumper. In addition, place chock blocks behind each wheel to prevent the trailer from rolling.

NEVER place the pump on **soft soil**. The suction hose or pipe connection should always be checked for tightness and leaks. A small suction leak in the hose or fittings could prevent the pump from priming.

ELEVATION

Elevations over 3,000 feet will effect the performance of the pump. Due to less atmospheric pressure at higher altitudes, pumps **DO NOT** have the priming ability that they have at sea level.

A general rule of thumb is that for every 1,000 feet of elevation above sea level, a pump will lose one foot of priming ability.

For example, in Flagstaff, Arizona where the elevation is approximately 7,000 feet, the pump would have a suction lift of only 18 feet rather than the 25 feet at sea level.

PUMP CLEAN-OUT

The clean-out cover on the MQ600H-HTB-HTP has been design for easy removal that allows for easy access to the wear plate and impeller for cleaning and servicing.

In order to comply with local laws regarding spark arresters, consult the engine distributor or the local Health and Safety Administrator.

MECHANICAL SEAL LUBRICATION

The pump uses a oil lubricated mechanical seal. The oil in the seal chamber lubricates the seal and prevents it from overheating. Never operate the pump without water in the casing as this may cause the seal to fail. Never pump chemicals which will attack the seals elastomers leading to premature failure (See section on seal maintenance).

ENGINE SAFETY

Internal combustion engines present special hazards during operation and fueling. Failure to follow the safety guidelines described in the Rules for Safe Operation section of this manual and the Hatz Engine Operator's Manual could result in severe injury or death.

ACCESSORIES

Multiquip offers a complete line of fittings, hoses, and clamps to properly connect the pump to match various job conditions. Refer to the part list section of this manual for a complete list of accessories.

LINE CONFIGURATION/LAYOUT

The pump performance is adversely affected by increased suction lift. Place the pump as close as possible to liquid being pumped. Always place pump on level ground to insure sufficient engine lubrication and fuel supply. If trailer-mounted, pump block wheels before operation. The lines near the pump must be properly supported. Never use shut-off valves.

SUCTION LINE

Use appropriate 6-inch diameter hoses, the suction hose must be rigid, reinforced to prevent collapse under suction. To prevent air pockets, the suction hose must be straight short as possible; the line must always slope upward from the water source to the pump. The line should not slope down or air pockets may occur. If liquid being supplied to pump is under pressure, the incoming pressure must be limited to 50% of the maximum operating pressure based on the pump engineering data curve.

DISCHARGED LINE

Maintain discharge lines straight as possible to prevent whipping and reduce friction loss. The line friction can be reduced with minimal use of fittings and elbows. If using elbows, wide radius is preferred. Always use strainer furnished with the pump.

FITTINGS

Use properly rated 6-inch size fittings. Align fittings to pump before tightening connections. The pump connections should be sealed with pipe sealant to ensure air tight seal. A slight leak will affect priming ability and output performance

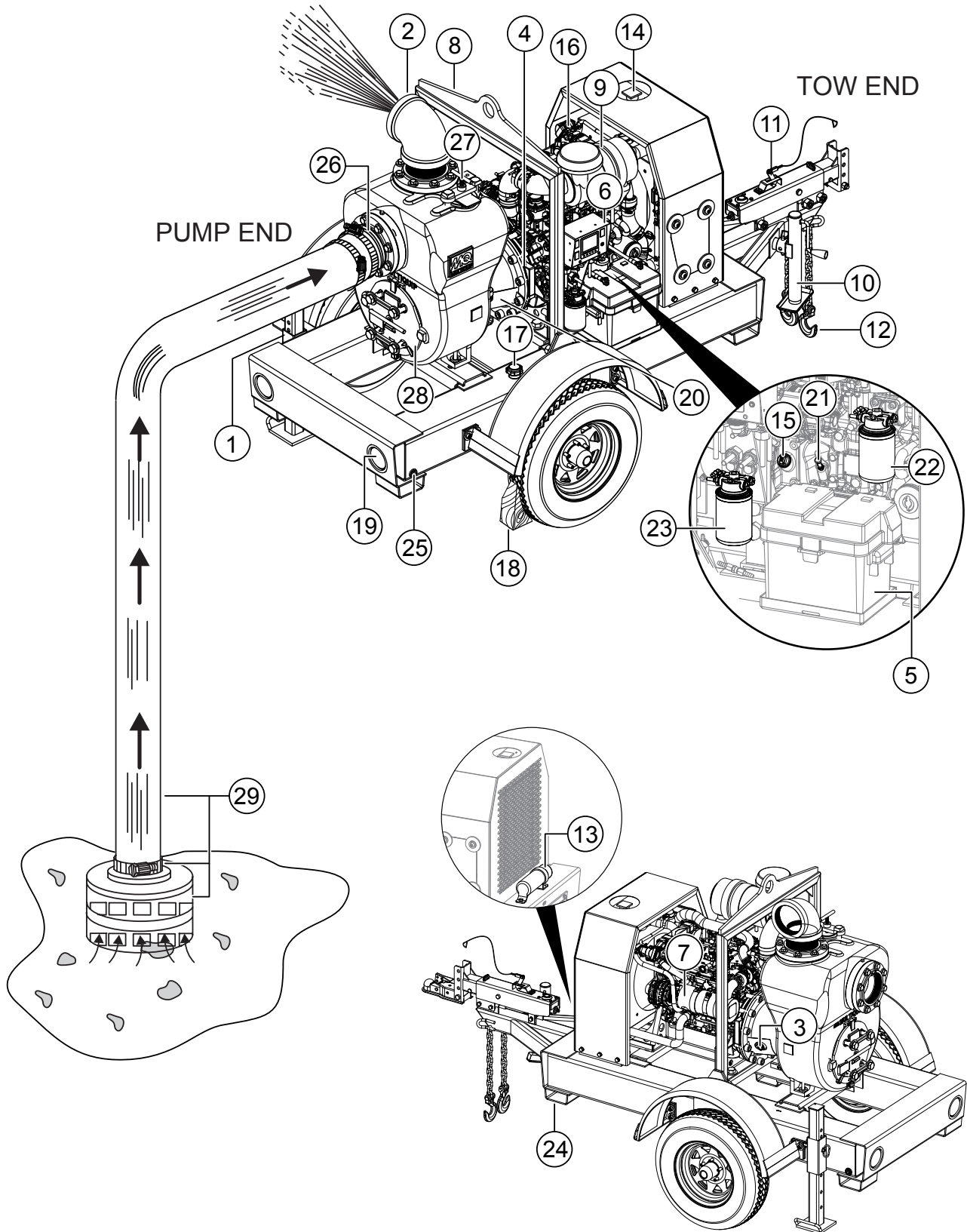

Figure 3. Pump Components

Figure 3 shows the location of the components and basic components for the MQ600H-HTB-HTP trash pump, The function of each component or control is described below:

1. **Pump End Jack Stand** — Use this jack stand to level and support the trash pump.
2. **Pump Discharge Port** — Discharges water and debris from the pump.
3. **Bearing Sight Glass** — Use this sight glass to determine if oil is present. Oil must be **visible** within the sight glass at all times.
4. **Mechanical Seal Sight Glass** — Use this sight glass to determine if oil is present. Oil must be **visible** within the sight glass at all times.
5. **+12 VDC Battery** — Not provided with pump. See Table 2 for battery specifications.
6. **Control Box Panel** — Monitors engine functions and will shut down the engine for low oil pressure, high coolant temperature, alternator charge and V-belt failure.
7. **Catalytic Converter** — **DO NOT** touch catalytic converter when engine is running. The converter can become extremely hot when engine is running causing severe burns.
8. **Lifting Bail** — When lifting of the trash pump by crane is required, use this lifting bail. **Note:** This lifting bail is balanced for a fully configured trash pump; removal of any trash pump components will unbalance the lifting bail.
9. **Air Cleaner** — Prevents dirt and any foreign debris from entering the engine. Service this unit as recommended in the maintenance section of this manual.
10. **Tow End Jack Stand** — Use this jack stand to level and support the trash pump.
11. **Brake Coupler/Channel** — This device will activate the hydraulic braking system of the pump's trailer in the event the pump's trailer becomes detached from the towing vehicle. Channel requires a 2-inch ball hitch (MQ600HTB) or a 3-inch pintle (MQ600HTP).
12. **Safety Chain** — Always attach safety chain to the towing vehicle. **NEVER** tow the trash pump with the safety chain unattached.
13. **Documentation Canister** — Contains documentation for the pump and engine.
14. **Radiator Cap** — Used to add coolant to the radiator.
15. **Oil Filler** — Fill as recommended in the maintenance section of this manual.
16. **Engine (Diesel)** — This pump uses a Hatz 4H50TIC air-cooled, 4-stroke diesel engine. See the Hatz Operation manual supplied with the trash pump for additional engine information.
17. **Fuel Gauge/Filler Port** — Read top of gauge to determine fuel level. Refuel using only recommended types of diesel fuels (see Hatz Operation Manual). **DO NOT** top off fuel. Wipe up any spilled fuel immediately.
18. **Chock Blocks** — Place these blocks (not included as part of the trash pump package) under each trailer wheel to prevent rolling.
19. **Trailer Lights** — Before towing trash pump, make sure that both trailer lights are functioning correctly. **NEVER** tow the trash pump if these lights are not working.
20. **Pump Shaft Guards** — To prevent injury to hands and fingers these two guard covers (one each side of pump housing) are to remain in place at all times when the pump is in use.
21. **Dipstick** — Read this gauge to determine the level oil in the engine crankcase. Fill with only recommended type oil as referenced in the maintenance section of this manual.
22. **Fuel Fine Filter** — This engine incorporates the use of a fuel spin-on canister filter. Maintain this filter as recommended in the maintenance section of this manual.
23. **Fuel Prefilter/Water Separator** — Removes water from the fuel system. Inspect and clean as recommended in the maintenance section of this manual.
24. **Support Channel** — The channel protects the fuel tank from being damaged when the pump frame is lying on a flat surface.
25. **Fuel Tank/Drain Plug** — The fuel tank is part of the frame (sides). It holds 40 gallons (151 liters) of diesel fuel. Remove this drain plug to drain the fuel tank.
26. **Pump Intake Port** — Intakes water and debris from the source.
27. **Fill Cap** — Remove this cap to prime the pump with water.
28. **Clean-Out Cover** — Remove this cover to clean and remove foreign debris from the trash pump.
29. **Accessories** — Hoses, strainers and clamps are the required accessory components for normal operation of this trash pump. Contact your nearest Multiquip dealer for information on the component.

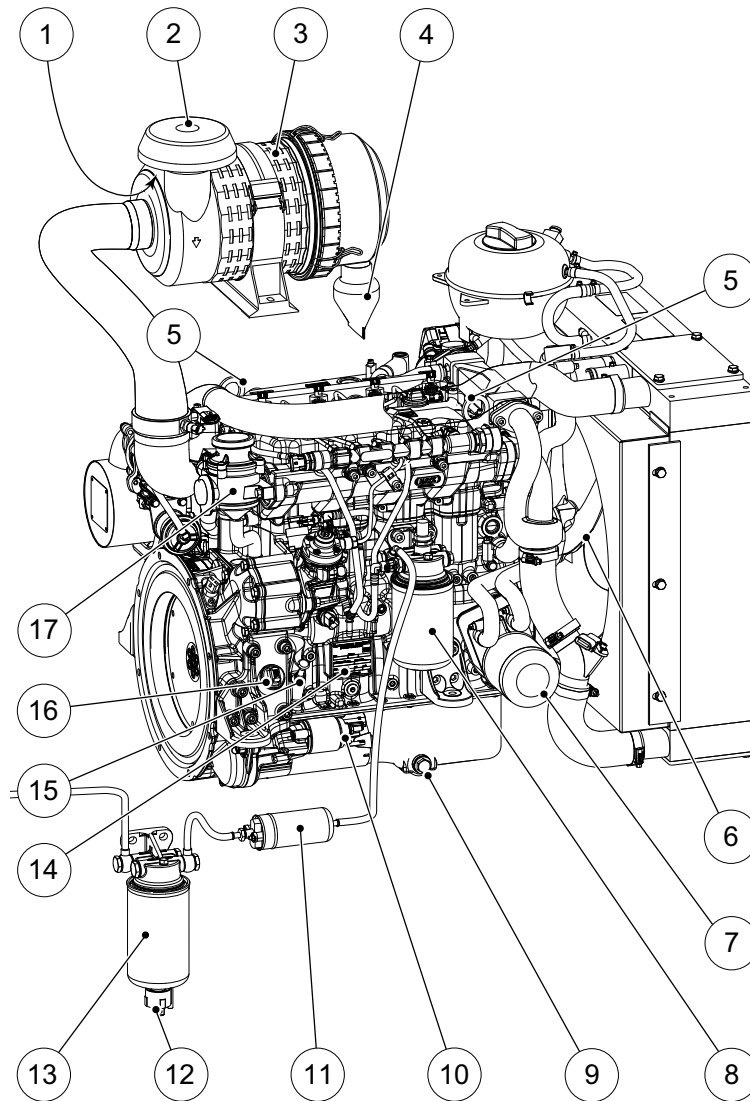

Figure 4. Hatz 4H50TIC Engine Components

- | | |
|--------------------------------------|-------------------------------------|
| 1. Intake Opening for Combustion Air | 10. Starter (Low Mounting Position) |
| 2. Rain Cap | 11. Electric Fuel Pump |
| 3. Air Filter (Optional) | 12. Drain Plug on Fuel Prefilter |
| 4. Dust Discharge Valve | 13. Fuel Prefilter |
| 5. Lifting Eyes | 14. Engine Type Plate |
| 6. Fan | 15. Dipstick |
| 7. Oil Filter | 16. Oil Filler Plug, Bottom |
| 8. Fuel Fine Filter | 17. Crankcase Ventilation |
| 9. Side Oil Drain Screw | |

APPLICATION

Figure 5 shows a typical application using the MQ600H-HTB-HTP diesel powered trash pump. Please note that this pump is intended for the removal of clean water and water containing some debris and solids. Maximum size of solids should not exceed 3 inches (76 mm) in diameter. **DO NOT** set strainer on bottom of water bed. Placing the strainer above the water bed will prevent the pump from drawing in excessive amounts of sand and foreign debris.

The following terms are usually used when referring to *lift* or *head*:

1. **Static Suction Lift** — The vertical distance from the water line to the center of the impeller (should not exceed 25 feet at sea level).
2. **Static Discharge Head** — The vertical distance from the discharge outlet to the point of discharge or liquid level when discharging into the bottom of a water tank.
3. **Dynamic Suction Head** — The static suction lift plus the friction in the suction line. Also referred to as **total suction head**.
4. **Dynamic Discharge Head** — The static discharge head plus the friction in the discharge line. Also referred to as **total discharge head**.
5. **Total Dynamic Head** — The Dynamic Head Suction Head plus the Dynamic Discharge Head. Also referred to as **total head**.

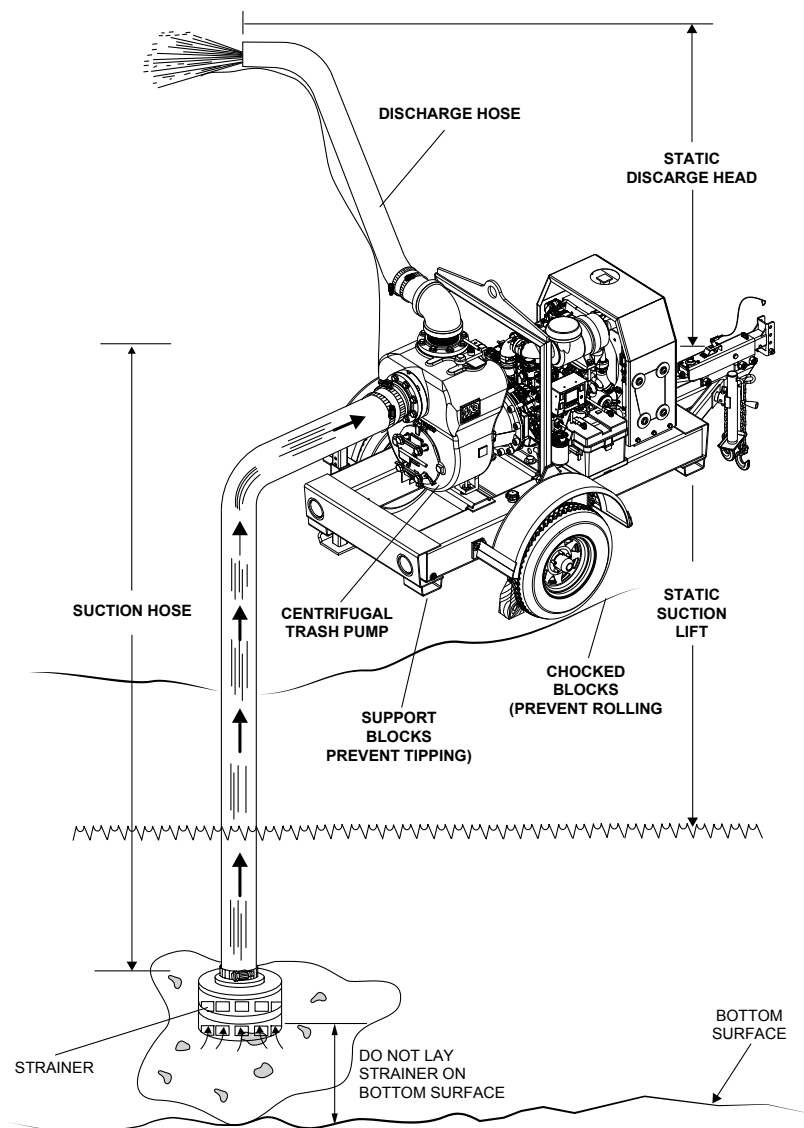

Figure 5. Pump Application

BATTERY CABLE INSTALLATION

ALWAYS be sure the battery cables are properly connected to the battery terminals (Figure 6). The **RED** cable is connected to the positive terminal of the battery, and the **BLACK** cable is connected to the negative terminal.

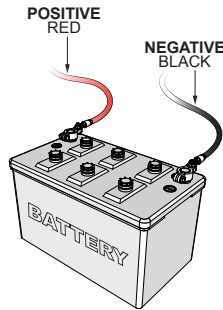

Figure 6. Battery Cable Connections

BEFORE STARTING

1. Read safety instructions at the beginning of manual.
2. Place pump as near to water as possible, on a firm flat, level surface.
3. To prime pump, remove fill cap (Figure 3) and fill pump case with water. If the pump case is not filled with water before starting, it will not begin pumping.

NOTICE

Pump casing **must** be filled with water before using pump, otherwise pump will not be able to begin pumping.

WARNING

Do not open fill cap if pump is hot! Water inside may be under pressure.

4. Check for **leaks** between pump and engine. If water is leaking between the pump and engine housing, the seal inside the pump may be worn or damaged. Continued operation of the pump is not recommended. Further usage of the pump under these conditions may cause severe water damage to engine.

HOSES AND CLAMPS

1. Check that all hoses are **securely** attached to the pump. Make certain suction hose does not have any air leakage. Tighten hose clamps and couplings as required.

2. It is recommended that 2 clamps be used when securing the suction hose to the inlet side of the pump.
3. Remember suction hoses must be **rigid** enough not to collapse when the pump is in operation.
4. Check that the **discharge** hose (Figure 3) is not restricted. Place hose so that it lays as straight as it is possible on the ground. Remove any twists or sharp bends from hose which may block the flow of water.

NOTICE

Suction and discharge hoses are available from Multiquip. Contact your nearest dealer for more information.

5. The discharge hose is usually a **collapsible** (thin-walled) hose, however if a thin-walled discharge hose is not available, a rigid suction hose can be substituted in its place.
6. Make sure the **suction strainer** is clean and securely attached to the water end of the suction hose. The strainer is designed to protect the pump by preventing large objects from being pulled into the pump.

CAUTION

The strainer should be positioned so it will remain completely **under water**. Running the pump with the strainer above water for long periods can damage the pump.

CAUTION

DO NOT pump flammable fluids, corrosive chemicals or fluids containing toxic substances. These fluids can create potentially dangerous health and environmental hazards. Contact local authorities for assistance.

7. Pipes, hoses, fittings and elbows all produce friction that can significantly reduce the flow of water. Keep hose length to a minimum and minimize the use of elbows and other fittings to reduce friction.
8. Always use a suction hose or pipe that matches the size of the pump inlet to insure optimum performance and reduce the risk of damage to the pump.
9. It is recommended that the discharge hose or pipe match the size of the pump outlet to reduce friction as much as possible. Using a discharge line that is larger than the pump outlet will reduce friction and improve water flow. Similarly, a smaller line will reduce water flow by increasing friction.

CAUTION

DO NOT attempt to start the engine unless the pump has previously been *primed* with water. Severe damage to the pump's mechanical seal will occur if pump has not been primed.

ENGINE OIL

1. Make sure pump/engine is on level ground.
2. Pull the engine oil dipstick from its holder and wipe it.
3. Reinsert the dipstick.
4. Pull out the dipstick and check the oil level (Figure 7).

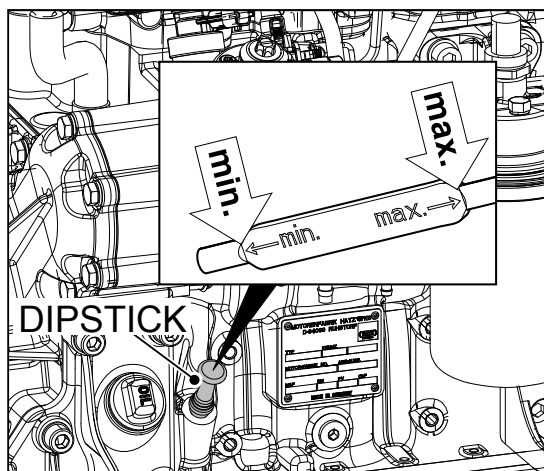

Figure 7. Engine Oil Dipstick

5. If the oil level is close to the "min." mark, add engine oil to the "max." mark through the oil filler hole. Depending on accessibility, use top oil filler hole (Figure 8) or bottom filler hole (Figure 9).

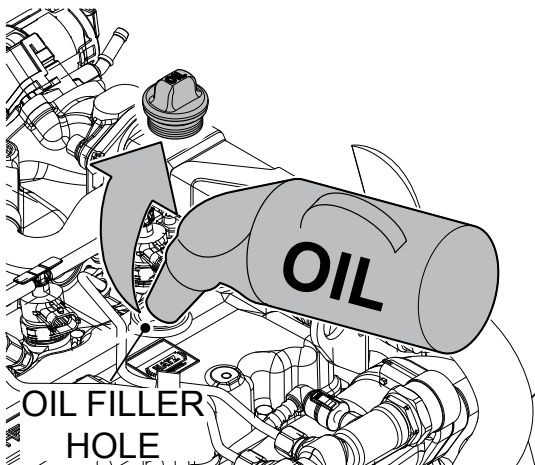

Figure 8. Engine Oil Filler Hole (Top)

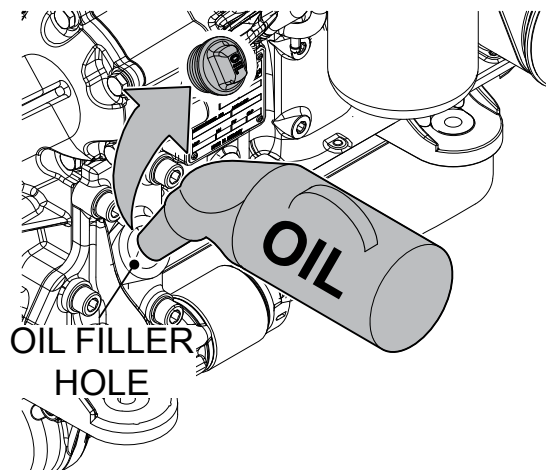
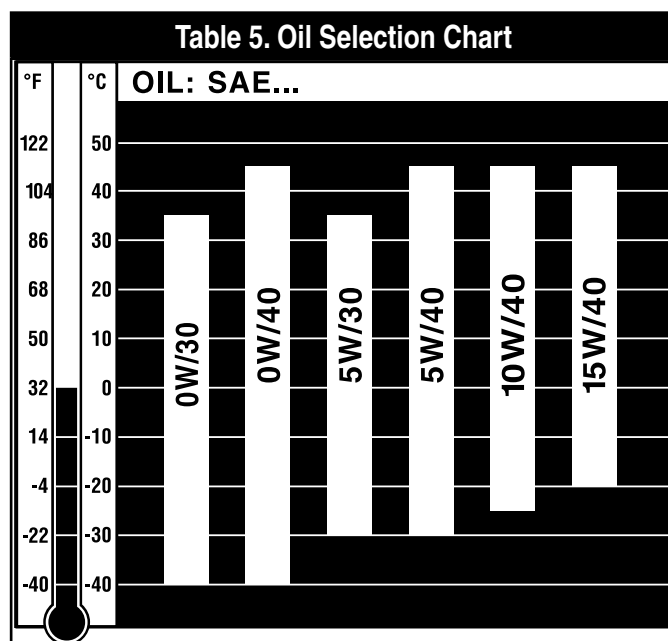

Figure 9. Engine Oil Filler Hole (Bottom)

6. The oil listed in Table 5 is recommended to ensure better engine performance.



FUEL

DANGER



NEVER fill the fuel tank while the engine is running or in the dark. Fuel spillage on a hot engine can cause a fire or explosion. If fuel spillage occurs, wipe up the spilled fuel completely to prevent fire hazards.

1. Determine if engine fuel is low by reading fuel indicator gauge on top fuel cap. Fill with recommended type diesel fuel. **DO NOT** fill the tank beyond capacity.

DANGER



DO NOT smoke while refueling. Motor fuels are highly flammable and can be dangerous if mishandled.

2. Handle fuel in a safety container. If the container does not have a spout use a funnel.
3. Pay attention to the fuel tank capacity when replenishing fuel. Refer to the fuel tank capacity listed in Engine Specifications Table.
4. Tighten fuel tank cap securely after filling.

CAUTION

The engine fuel injection system develops 1800 Bar (26,000 PSI). **DO NOT** loosen or open injector lines. Serious injury may result.

CONTROL PANEL

1. Turn on the control panel by turning the key switch to the on position (Figure 10).

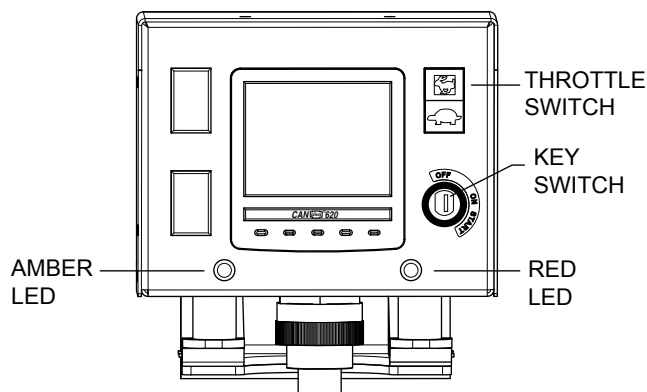

Figure 10. Control Panel

2. After a brief self-test, the display will initially show the analog gauges (see Figure 11). On subsequent startups, the screen that was last used will be displayed.



Figure 11. Initial Screen - Analog Gauges

3. In cold weather, the preheat window will pop up on the display and will close when preheat is complete.
4. Once preheat is complete, turn the key switch to the start position. The switch will return to the on position when released.

GAUGE DISPLAYS

1. With the initial screen displayed, press any of the first white buttons to display the button bar on the bottom of the screen (Figure 12).

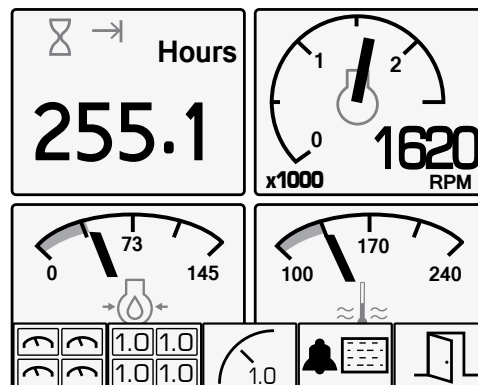

Figure 12. Button Bar

2. The button bar indicates the current function of the white buttons below the display. The button bar disappears after 5 seconds if no button is pressed. To remove it from the screen before the 5 seconds are up, press the fifth (close) button.
3. With the button bar displayed, press the corresponding button for the desired function (Figure 13). Successive presses of the button will cycle through the pages.

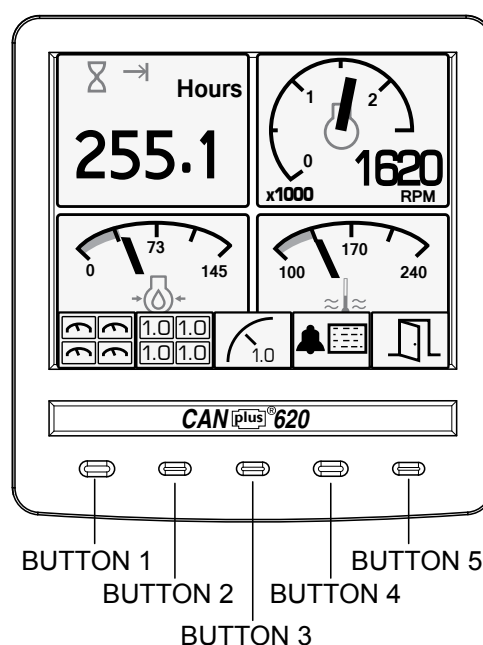

Figure 13. Button Functions

Analog Gauge Pages

If the analog gauge button (Button 1) is selected, the following display pages (Figure 14 to Figure 17) will be shown with each press of the button. Refer to Table 6 for meaning of symbols displayed in the different pages.

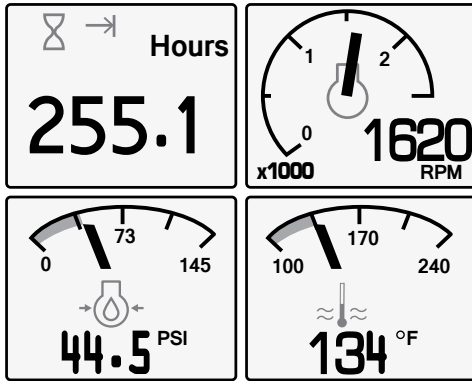

Figure 14. Analog Gauge - Page 1

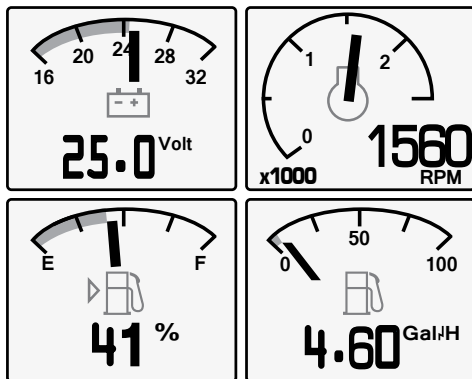

Figure 15. Analog Gauge - Page 2

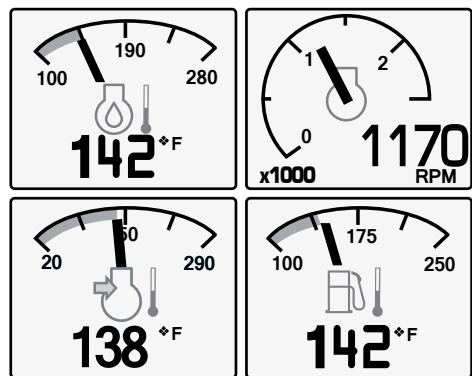

Figure 16. Analog Gauge - Page 3

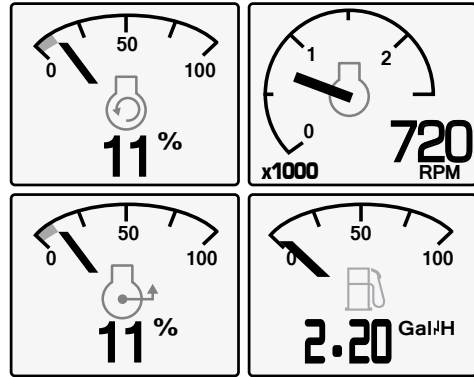

Figure 17. Analog Gauge - Page 4

Digital Gauge Pages

If the digital gauge button (Button 2) is selected, the following display pages (Figure 18 to Figure 21) will be shown with each press of the button. Refer to Table 6 for meaning of symbols displayed in the different pages.

NOTICE

The digital gauge pages display the same data as the analog gauge pages but in digital format.

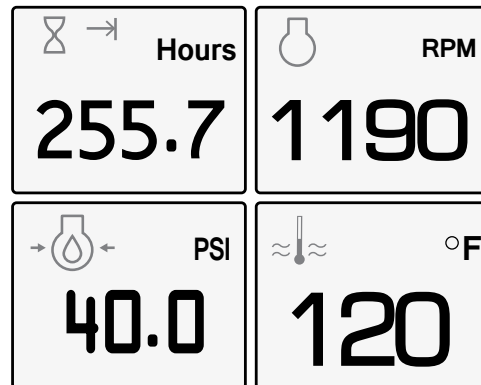

Figure 18. Digital Gauge - Page 1

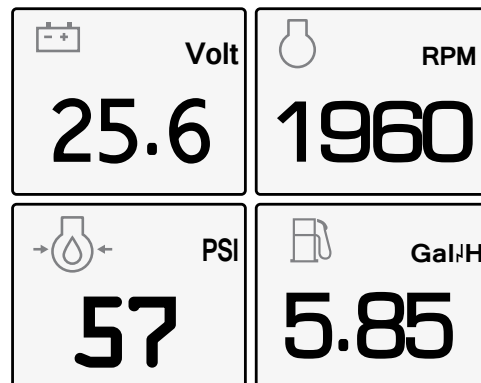

Figure 19. Digital Gauge - Page 2

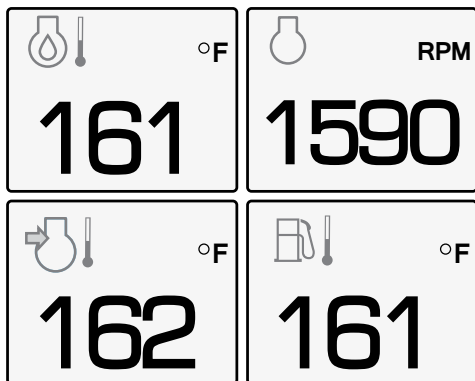

Figure 20. Digital Gauge - Page 3

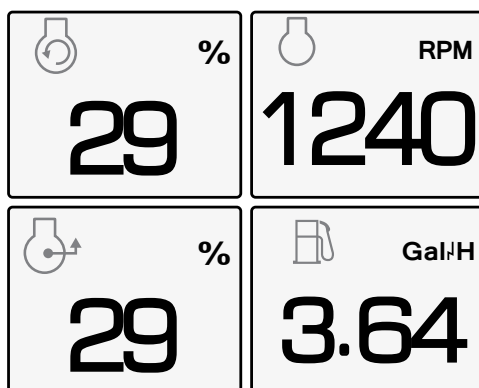

Figure 21. Digital Gauge - Page 4

Single Analog Gauge

If single analog gauge button (Button 3) is selected, the entire screen will display a single large analog gauge (Figure 22). Press button 3 repeatedly to scroll through the available analog gauges.



Figure 22. Single Analog Gauge (RPM)

Active Fault List

1. If active fault list button (Button 4) is selected, the fault list is displayed (Figure 23).

TOTAL ALARMS = 10		
SRC	DESCRIPTION	FAIL MODE
10.	ENG OIL PRESS.	
0x00	ENG HRS = 248	TOO LOW MS
	SPN = 100	FMI = 1
	OCC CNT = 8	
9.	AIR INLET PRESS.	
0x00	ENG HRS = 248	FMI = 29
	SPN = 106	
	OCC CNT = 10	
8.	INTAKE MANIFOLD TEMP	
0x00	ENG HRS = 248	UNKNOWN
	SPN = 105	FMI = 11
	OCC CNT = 9	



Figure 23. Active Fault List

2. If there are no active faults, a blank list will be displayed with the message "No Active Faults" (Figure 24).

Total Alarms = 0		
SRC	Description	Fail Mode
No Active Faults		



Figure 24. No Active Faults

3. When a fault occurs, a flashing pop-up shows the fault description and the beeper sounds (Figure 25).

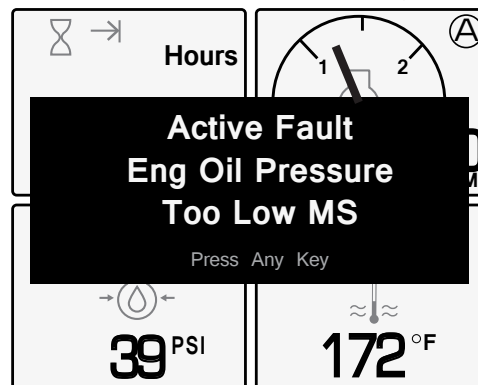

Figure 25. Fault Pop-Up

- Press any button to display the Active Fault List. The list will be highlighted (Figure 26) and the beeper will continue to sound.

Total Alarms = 10		
SRC	Description	Fail Mode
10.	Eng Oil Pressure	
Ox00	Eng Hrs = 248	Too Low MS
	SPN = 100	FMI = 1
	Occ Cnt = 8	
9.	Air Inlet Press.	
Ox00	Eng Hrs = 248	FMI = 29
	SPN = 106	
	Occ Cnt = 10	
8.	Intake Manifold Temp	
Ox00	Eng Hrs = 248	FMI = 11
	SPN = 105	
	Occ Cnt = 9	

↑
↓
🔔
STORED

Figure 26. Unacknowledged Fault List

- Press button 3 to acknowledge fault. The fault list will no longer be highlighted (Figure 27), the beeper stops, and button 5 (close) becomes available.

Total Alarms = 10		
SRC	Description	Fail Mode
10.	Eng Oil Pressure	
Ox00	Eng hrs = 248	Too Low MS
	SPN = 100	FMI = 1
	Occ Cnt = 8	
9.	Air Inlet Pressure	
Ox00	Eng hrs = 248	FMI = 29
	SPN = 106	
	Occ Cnt = 10	
8.	Intake Manifold Temp	
Ox00	Eng hrs = 248	Unknown
	SPN = 105	FMI = 11
	Occ Cnt = 9	

↑
↓
🔔
STORED
🚪

Figure 27. Acknowledged Fault List

- If button 5 is pressed to close the fault list screen, an active fault indicator (Ⓐ) will show in the top right of the display as long as a fault is active. The fault indicator disappears when active fault message stops. The fault list will then be cleared.

Inactive Faults

- Inactive faults (Figure 28), also called stored or previously active faults, list the fault history. To access, press button 4 (STORED) while on the Active Fault List display.

Total Stored Alarms = 10		
SRC	Description	Fail Mode
10.	Eng Oil Pressure	
Ox00	Eng hrs = 248	Too low MS
Ⓐ	SPN = 100	FMI = 1
	Occ Cnt = 8	
9.	Air Inlet Pressure	
Ox00	Eng hrs = 248	FMI = 29
Ⓐ	SPN = 106	
	Occ Cnt = 10	
8.	Intake Manifold Temp	
Ox00	Eng hrs = 248	Unknown
Ⓐ	SPN = 105	FMI = 11
	Occ Cnt = 9	

↑
↓

↶

Figure 28. Inactive Fault List

- If no stored faults are available, a blank list is displayed with the message "No Inactive Faults" (Figure 29).

Total Stored Alarms = 0		
SRC	Description	Fail Mode
No Inactive Faults		

↑
↓

↶

Figure 29. No Inactive Faults

- A pop-up displays "No Response From Engine" (Figure 30) if the unit does not respond to the active fault request.

Total Stored Alarms = 0		
SRC	Description	Fail Mode
<div style="border: 2px solid black; padding: 10px; width: fit-content; margin: auto;"> No Response From Engine </div>		

↑
↓

↶

Figure 30. No Response From Engine

ADJUSTING BACKLIGHT AND CONTRAST

1. When no button bar is displayed, press button 5 to access the backlight and contrast menu bar (Figure 31).

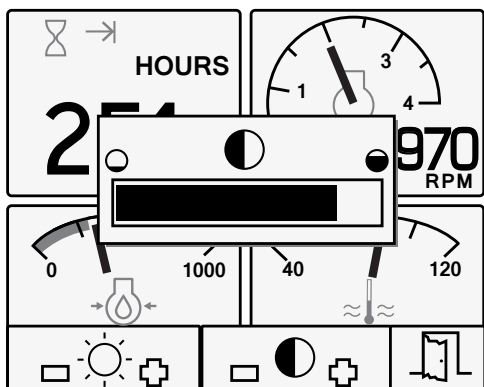

Figure 31. Backlight and Contrast

2. Press button 1 to decrease backlight or button 2 to increase backlight.
3. Press button 3 to decrease contrast or button 4 to increase contrast.

CONFIGURATION MENU

1. To access the configuration menu (Figure 32), press and hold button 5 for at least 3 seconds from any display.

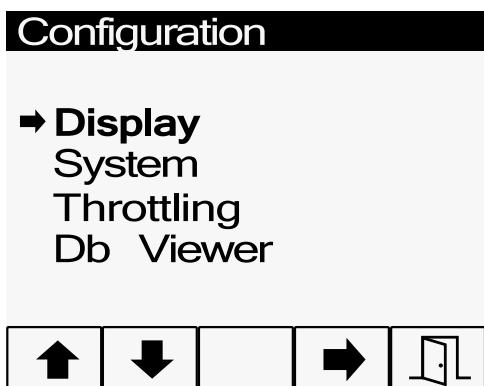

Figure 32. Configuration Menu

2. The configuration menu has four submenus for different parameters and diagnostic information (Figure 33 to Figure 36).

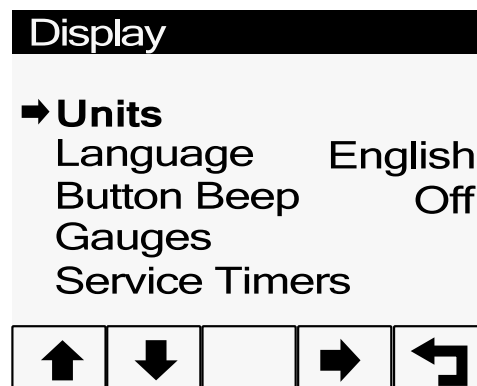

Figure 33. Display Menu

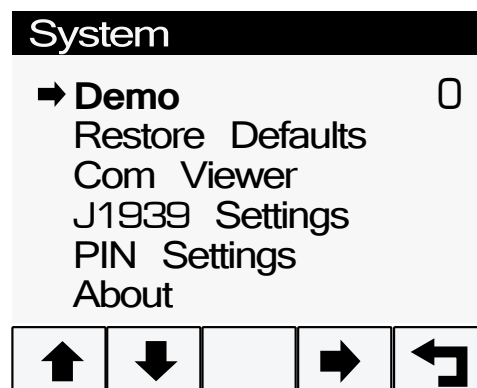

Figure 34. System Menu

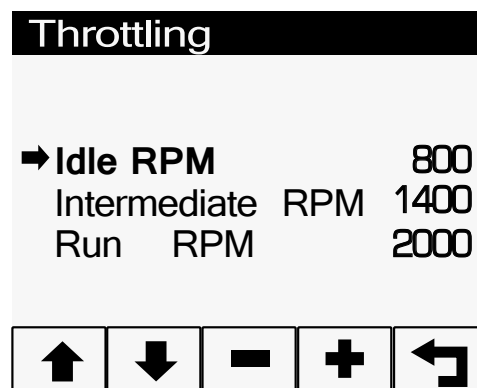

Figure 35. Throttling Menu

DISPLAY DATA BASE VIEWER	
EXT COOLANT PRESS:	92 kPa
FUEL DELIV PRESS:	210 kPa
FUEL LEVEL:	29 %
OIL PRESSURE:	278 kPa
TURBO PRESSURE:	170 kPa
AIR INLET PRESS:	172 kPa
BARO PRESSURE:	72 kPa
COOLANT TEMP:	78 °C
TRANS OIL PRESS:	1514 kPa











				
---	---	---	---	---

Figure 36. Db Menu

Configuration Menu Navigation

The following buttons are used in navigating the configuration menu.

-  — Move selection up on the menu.
-  — Move selection down on the menu.
-  — Decrease the selected value.
-  — Increase the selected value.
-  — Return to the previous menu.
-  — Exit the configuration menu.

NOTICE

Most parameters can be changed or modified. Infrequently changed and restricted parameters (such as Maximum RPM) are normally only accessible with the CANplus Configuration Kit. Contact Multiquip Technical Support for detailed instructions on how to program the different parameters and for more information on the configuration kit.

Table 6. Description of Icons

Icon	Description	Icon	Description	Icon	Description
Electrical			Air Filter Differential Pressure	Percentage (%)	
	Electrical Potential		Injector Metering Rail 1 Pressure		Acceleration Position
	Switched Battery Voltage, Net Battery Current		Injector Metering Rail 2 Pressure		Engine Oil Level
	Alternator Current, Alternator Voltage		Engine Coolant Pressure		Coolant Level
Fuel			Engine Oil Pressure		Fan Speed
	Fuel Level		Transmission Oil Pressure		Driver's Demand Percent Torque
	Fuel Rate		Clutch Pressure		Actual Engine Percent Torque
	Fuel Temperature		Air Start Pressure		Percent Load at RPM
	Instantaneous Fuel Economy, Trip Fuel Rate		Injector Control Pressure	Time	
	Trip Fuel Economy	Temperature			Total Engine Hours
	Trip Fuel		Engine Coolant Temperature		Trip Engine Hours
Distance			Engine Intercooler Temperature	Speed	
	Distance Remaining		Engine Oil Temperature		Input Shaft Speed
	Trip Distance		Transmission Oil Temperature		Output Shaft Speed
	Total Vehicle Distance		Turbo Oil Temperature		Engine Speed
Pressure			Intake Manifold Temperature		Turbo 1 Speed
	Fuel Pressure		Air Inlet Temperature		Engine Desired Operating Speed
	Barometer Pressure		Exhaust Temperature		Fan Speed
	Auxiliary Pressure 1		Auxiliary Temperature 1		Vehicle Speed
	Turbo Pressure		Exhaust Gas Port Temperature		
	Air Inlet Pressure		Turbo Inlet Temperature		

OPERATION

1. With the throttle switch on, the MQ600H-HTB-HTP trash pump should begin pumping water within a minute depending on the length of suction hose and height the pump is above water.
2. Press the throttle switch to increase speed.

NOTICE

Longer suction hoses will require more time for the pump to begin pumping water.

3. If pump does not begin to pump water after a few minutes, check for loose connections or air leaks in suction hose. Make sure there is water in the pump end and strainer is not clogged with debris. Refer to Pump Troubleshooting Table.
4. To shut down engine, slow down the engine and allow to cool for at least 2 minutes. Turn the key switch on the control panel to the **OFF** position.

GENERAL INSPECTION

The following maintenance guidelines are intended to assist the operator in preventative maintenance. For a more detailed maintenance schedule refer to the **Engine Manual** supplied with the pump.

At least **daily** or prior to each use, the MQ600H-HTB-HTP trash pump cover should be removed, and the pump should be cleaned and inspected for deficiencies. Check for loose, missing or damaged nuts, bolts or other fasteners. Also check for fuel or oil leaks, and remove any debris stuck in the impeller or volute.

CHECK OIL LEVEL

Check the engine crankcase oil level prior to each use, or every 8 to 15 hours of operation. Make sure the pump is level. The oil level must be between the "min." and "max." mark on the dipstick as shown in Figure 7.

CHANGING ENGINE OIL

Change engine oil with the correct type and amount oil (see Table 5) after 500 hours of operation or every 2 years.

1. Drain used oil, into a suitable container, while engine is still warm. Use side or front drain plug depending what is more accessible.

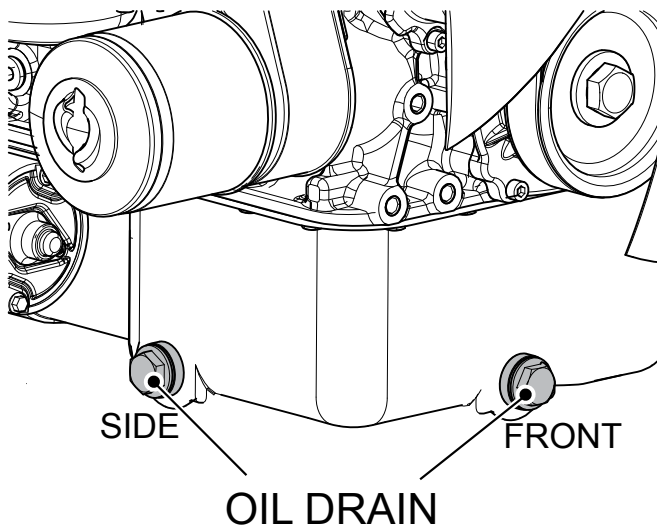

Figure 37. Oil Drain

2. Replace the drain plug tightly when done.
3. Add oil through the filler hole.

CHANGING OIL FILTER

Change the engine oil filter every 500 hours or every 2 years of operation.

1. Loosen the oil filter (Figure 38) with a strap wrench or similar tool and unscrew it.

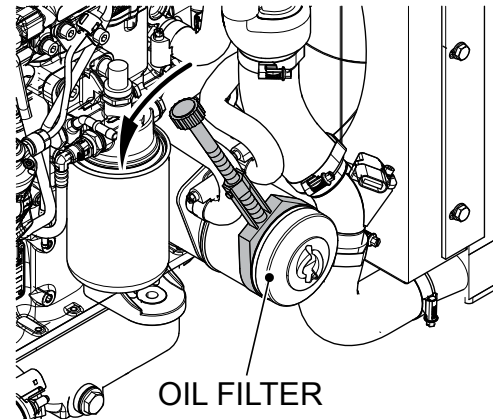

Figure 38. Removing Oil Filter

2. Dispose of the old filter in accordance with local environmental regulations.
3. Thoroughly clean the sealing surface (Figure 39).

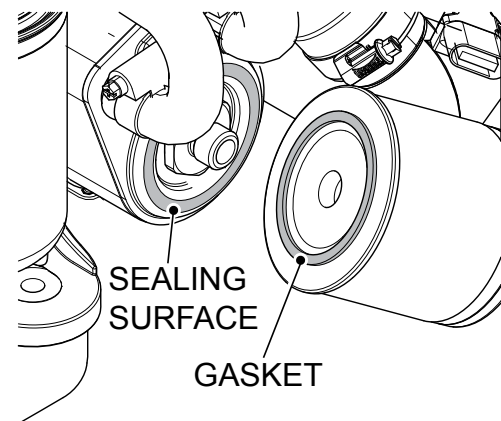

Figure 39. Changing Oil Filter

4. Lightly oil the gasket of the new oil filter.
5. Screw in the oil filter and tighten by hand.

FUEL PREFILTER

Replace the in-line fuel filter every 500 hours or every 2 years.

1. Block the fuel feed line with a hose clip (Figure 40) between the fuel tank and fuel prefilter.

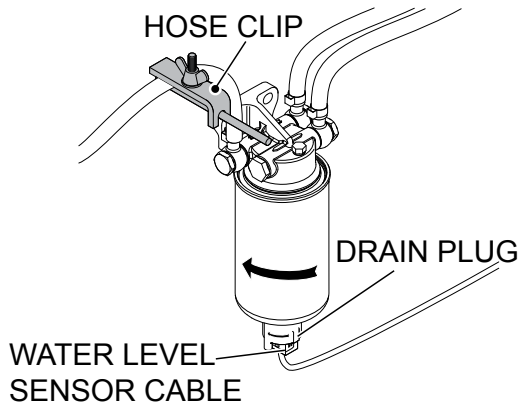

Figure 40. Fuel Prefilter

2. Place a suitable container under the filter to collect emerging fuel.
3. Disconnect the water level sensor cable from the drain plug.
4. Release the drain screw and drain the fuel.
5. Unscrew the fuel prefilter. Fully unscrew the drain plug with integrated water level sensor.
6. Dispose of the used fuel prefilter according to local environmental regulations.
7. Clean the drain plug with integrated water level sensor and lightly oil the sealing surfaces. Screw in the drain plug into the new fuel prefilter.
8. Lightly oil the gasket of the new fuel prefilter, fit the filter and tighten it by hand.
9. Release the fuel feed line and connect the cable of the water level sensor.

FUEL PREFILTER WATER SEPARATOR

The fuel prefilter has a water separator. An electronic water level sensor signals when the maximum permissible water level is reached in the water separator. To drain water separator, perform the following procedure.

1. Place a suitable container under the drain socket of the drain plug (Figure 41).

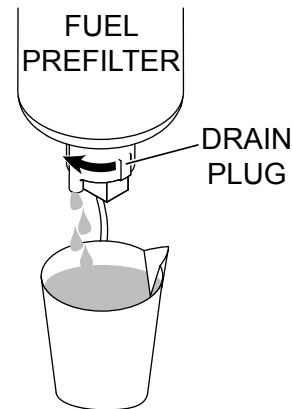

Figure 41. Fuel Water Separator Filter

2. Open the drain plug to drain water into the container.
3. As soon as fuel escapes, close the drain plug.
4. Dispose of the water-fuel mixture in an environmentally-compatible manner.

FUEL FINE FILTER

Replace the fuel fine filter every 500 hours or every 2 years.

1. Block the fuel feed line using the hose clip (Figure 42).

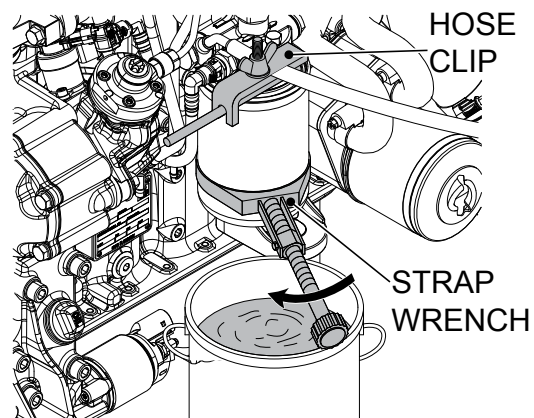

Figure 42. Fuel Fine Filter

2. Place a suitable container under the filter to collect emerging fuel.

3. Unscrew the fuel fine filter with a strap wrench and dispose according to local environmental regulations.
4. Lightly oil the gasket of the new fuel fine filter, fit the filter, and tighten it by hand.
5. Release the fuel feed line.

CRANKCASE BREATHER FILTER

Replace the crankcase breather filter every 500 hours or every 2 years.

1. Release the four mounting bolts on the breather cap (Figure 43).

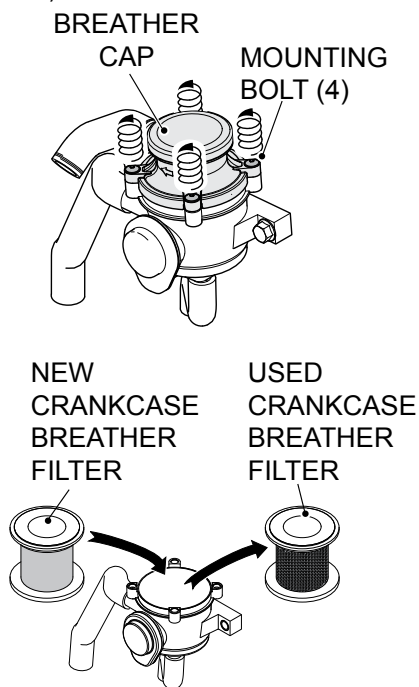

Figure 43. Replacing Crankcase Breather Filter

2. Remove the old crankcase breather filter and dispose properly.
3. Wipe the breather housing clean and install the new crankcase breather filter.
4. Reinstall the breather cap and tighten the four mounting bolts (4 Nm maximum torque).

FUEL TANK

Unscrew the fuel drain plug on the fuel tank (Figure 44) to remove water and sediment every 500 hours. If the purity of the fuel being used is of lesser quality, drain the fuel tank more frequently.

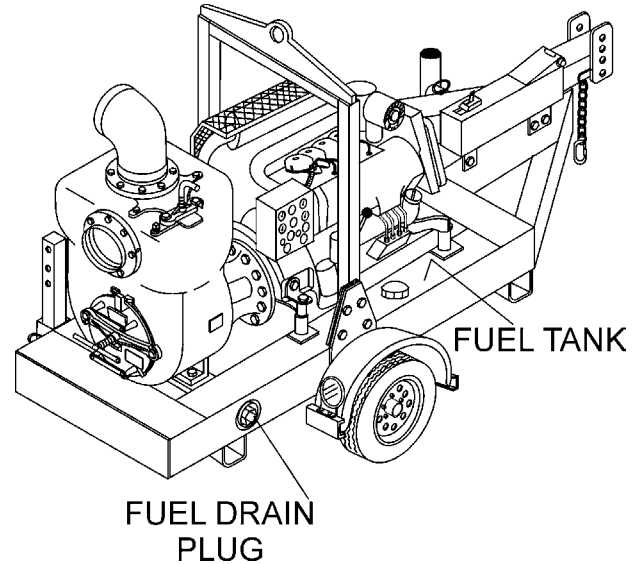

Figure 44. Fuel Tank/Drain Plug

POLY V-BELT TENSIONING AND REPLACEMENT

1. Check the tension of the V-belt and tighten as needed.

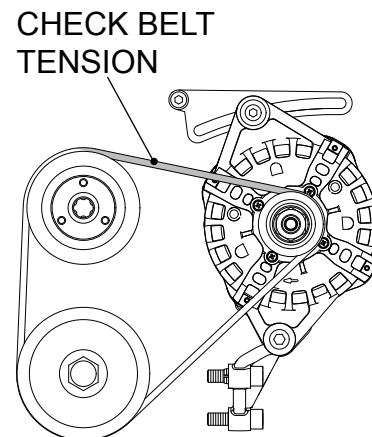

Figure 45. V-Belt Tensioning

2. Regularly check the poly V-belt for wear. If wear is detected (Figure 46), the belt must be immediately replaced.

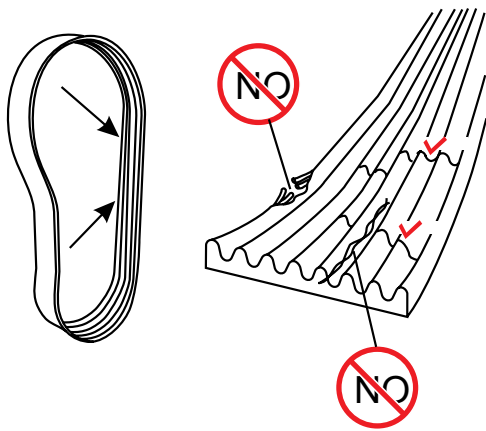

Figure 46. Wear and Tear Check

AIR FILTER

Change or clean filters every 500 operating hours or when indicated, or at least every 2 years.

To replace filters:

1. Locate the air filter on the service side of the engine.
2. Release the metal harness strap that holds the air filter in place (Figure 47)

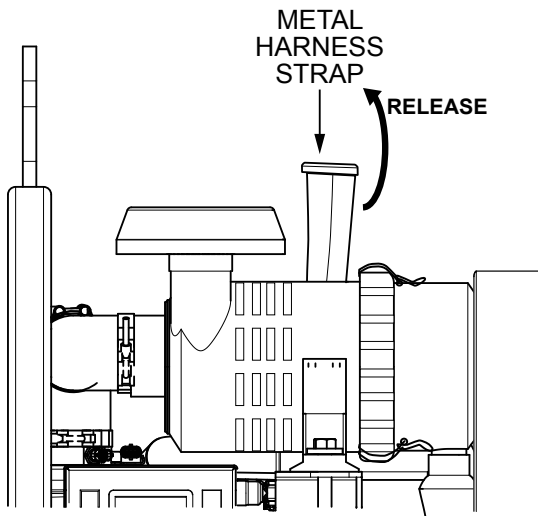

Figure 47. Releasing Metal Harness Strap

3. Raise the main canister, unlatch the three end fasteners and remove the canister cap (Figure 48).

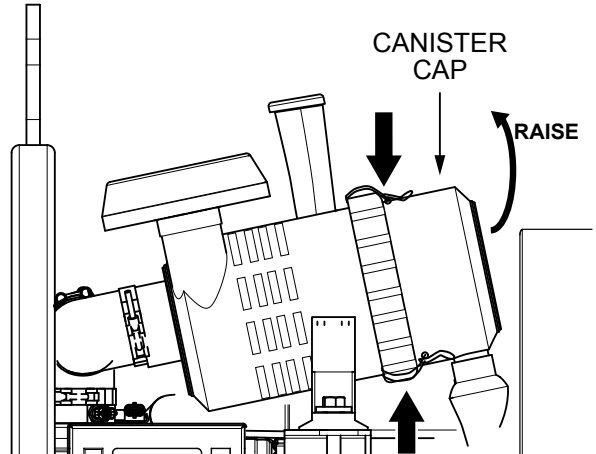

Figure 48. Raising the Main Canister

4. Pull out the primary filter from the main canister (Figure 49).

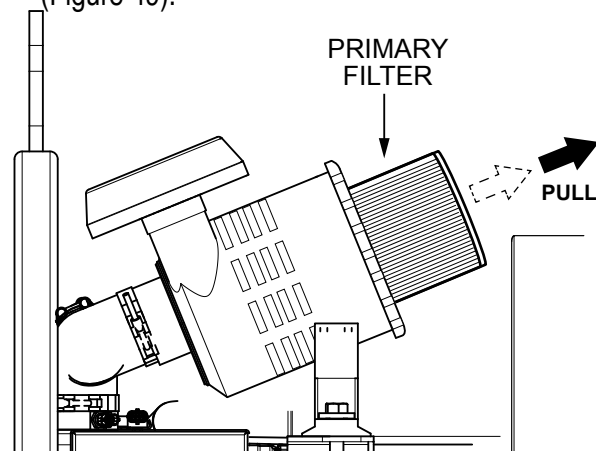

Figure 49. Primary Filter

5. If there are tears and damage or when there is oily or damp dirt contamination, the filter needs to be replaced.
6. Pull out and check the secondary filter (Figure 50) and replace if required. The secondary filter can not be cleaned.

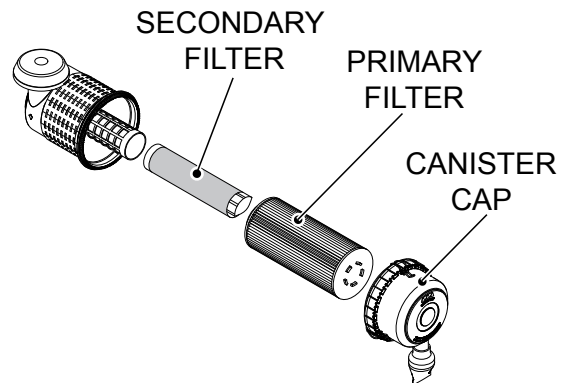

Figure 50. Secondary Filter

7. Carefully insert new filter elements and replace cover.

To clean primary filter:

1. Blow out the primary filter with dry compressed air from the inside to the outside until dust no longer emerges.
2. Make sure not to touch the filter paper.

NOTICE

The primary filter may only be cleaned once, then it must be replaced.

PUMP VACUUM TEST

CAUTION

DO NOT attempt to start the engine unless the pump has previously been **primed** with water. Severe pump damage will occur if pump has not been primed.

To perform the pump vacuum test do the following:

1. Remove the pump fill cap, and fill the pump with water.
2. Start the engine as outlined in the initial start-up section, and wait for the pump to begin pumping. Confirm engine is operating at 2,000 RPMs.
3. As shown in Figure 51, place a water hose inside the discharge opening of the pump, and turn on the water. This flow of water into the discharge opening will prevent the pump from running dry.

4. Place the Pump Vacuum Tester over the pump inlet opening (Figure 51) with the vacuum gauge facing upwards. It may be necessary to apply a small amount of water around the rubber seal of the vacuum tester.
5. Check and make sure that there are no air leaks between the vacuum tester and the inlet port on the pump. If air leaks are present reseal vacuum tester.
6. Run the pump for a few minutes while monitoring the vacuum gauge. A pump will lose approximately one foot of suction lift for every 1,000 feet of elevation. Depending on the elevation, the gauge should read between 20-29 in. Hg. (inches of mercury). This is an indication that the pump is working correctly.
7. If the vacuum tester gauge indicates a reading **below** -20 in. Hg, it can then be assumed that the pump is not functioning correctly, and corrective action needs to be taken.

NOTICE

25 in. Hg (inches of mercury) translates into 25 feet of lift at sea level.

CAUTION
DO NOT RUN PUMP
WITHOUT WATER.

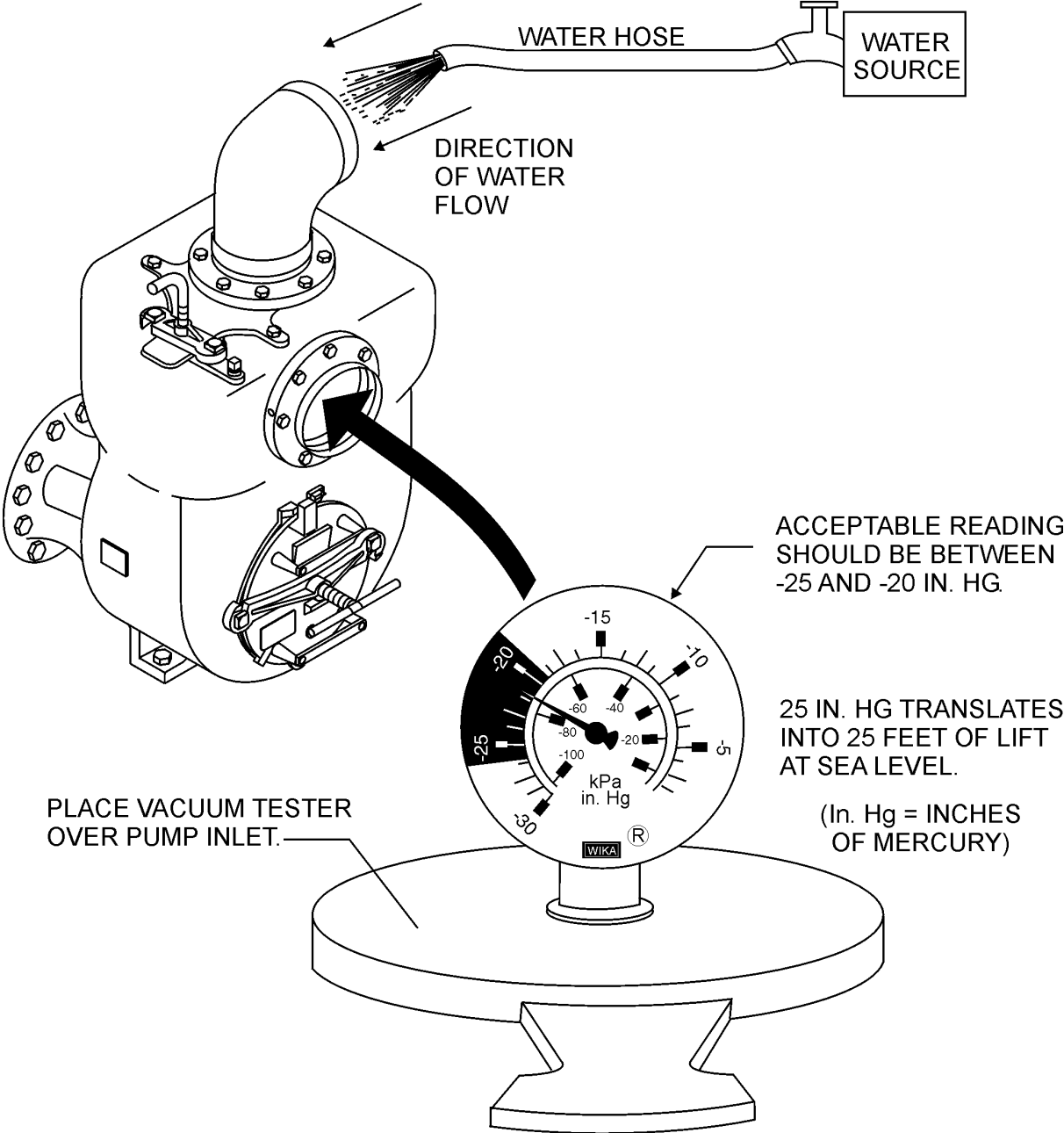

PUMP VACUUM TESTER

Figure 51. Pump Vacuum Tester

PUMP MAINTENANCE

This section is intended for the experienced, qualified technician as a guideline to service the pump. All service precautions must be observed to avoid injury. Read and understand all safety information and the operation section. Before servicing this equipment be sure to do the following:

1. Turn off the engine
2. Follow lock out procedures.
3. Vent the pump cautiously.
4. Drain the pump.
5. Allow the pump to cool if overheated.
6. Use appropriate lifting devices.

Mechanical Seal Replacement Instructions

Disassembly

1. It is recommended to remove the main casing body.
2. Remove the impeller by using a special engine crankshaft locking tool.
3. Using a soft-faced mallet, remove impeller by tapping vane in counterclockwise direction.
4. Remove mechanical seal components.
5. Remove the rear adaptor cover, sight glass, and vent tubes.
6. Using a punch, remove adaptor plate mechanical seal stationary seal plate.
7. Remove stationary oil seal.

Installation

1. Install new stationary oil seal into adaptor case housing. The seal spring should face inward towards the impeller.
2. Lightly lubricate the mechanical seal stationary seal plate O-ring and gently tap into adaptor plate making sure it is level with the O-ring groove facing the impeller.
3. Install the adaptor plate bolting onto the intermediate bearing housing.
4. Inside the adaptor plate cavity, assemble the stationary

plate by installing the O-ring then the tungsten carbide stationary element squarely onto the stationary seal plate. (Note: Tungsten element chamfer side towards pump end). A slight amount of grease can be used to allow retention. Double check that the Tungsten carbide element surface is free of dirt contamination including fingerprints.

5. Coat the mechanical seal bellows with a light drop of lubricating oil. Slide the seal bellows onto the shaft sleeve until flush with the sleeves chamfered end. Place the Tungsten carbide rotating element onto seal cage, the chamfered side towards engine. Inspect the rotating Tungsten for cleanliness. Use a slight amount of grease for retention. Carefully push and rotate the sleeve assembly onto the shaft until the Tungsten element faces are mated. The sleeve should firmly rest against the shaft shoulder. Use extreme care not to damage or roll over the oil seal lip.
6. **Alternative mechanical seal installation method**— After installation of adaptor plate assembly, slide the sleeve chamfered side toward engine. Use extreme care not to damage the oil seal. Utilize secondary sleeve as installation tool, installing over shaft butting against primary sleeve. Lubricate seal bellows slowly sliding seal assembly onto primary sleeve until the Tungsten carbide faces are squarely mated. Remove installation tool.
7. Assemble the spring then add the necessary adjustment shims.
8. Inspect the impeller and shaft threads and make sure they are clean before installation. Apply "Anti-Seize" compound. Even the slightest amount of dirt on the thread can cause the impeller to seize or make future removal difficult. At the slightest sign of binding, immediately back impeller off inspecting threads. Do not force the impeller onto the shaft. The impeller rear to adaptor plate clearance is 0.25 - 0.40 inches (0.64 - 1.02 mm). Make positively sure that the impeller is fully tightened utilizing all the threads. If not properly tightened, the impeller could further tighten jamming into the adaptor plate during pump operation, seizing the engine.
9. Reinstall the main pump body, checking for proper wear plate to impeller clearance.

Oil Lubrication

Mechanical Seal

1. Place the pump on level ground.
2. Fill the sight glass with SAE #30 non-detergent oil through the sight glass vent cap.
3. Check the oil level regularly.
4. Inspect for discoloration which may indicate that the mechanical seal is beginning to leak, passing water into the lubrication cavity.
5. The reservoir capacity is 3.3 oz. (0.1 liter).

NOTICE

If lubricating after mechanical seal replacement, it is recommended to purge seal cavity of air by removing the weep hole plug found opposite to the sight glass. Fill sight glass with oil until visible from the weep hole. Reinstall plug, filling sight glass to proper level.

Main Bearings

1. Place pump on level ground.
2. Fill sight glass with SAE #30 non-detergent oil through the top access port until visible.
3. Monitor the lubrication for evidence of moisture condensation particularly in areas with unusual temperature variations.
4. Do not over-lubricate. Excess oil can cause the bearings to overheat resulting in premature failure.
5. Under normal conditions, drain and refill each year.
6. The oil reservoir oil capacity is 8.45 oz. (0.259 liter).

Impeller/Wear-Plate Clearance

1. For optimal performance, the recommended clearance between the impeller and the wear plate is 0.10 - 0.20 inches (0.25 - 0.51 mm). The clearance can be inspected by reaching with feeler gauge inside the discharge or fill ports.
2. Adjustment is made by removing the main pump housing, adding or subtracting gaskets located between the adaptor plate and the main housing. Typically only one or two gaskets are used.

PREPARATION FOR LONG TERM STORAGE

For storage of the pump for over 30 days, the following is required:

- Drain the fuel tank completely.
- Run the engine until the fuel in the injection system is completely consumed.
- Completely drain used oil from the engine crankcase and fill with fresh clean oil, then follow the procedures described in the engine manual for engine storage.
- Remove the drain plug from the pump and drain out any water from left in the housing.
- Remove the pump cover and clean inside of pump housing. Coat inside of pump housing with a light film of oil to reduce corrosion. A spray can of oil works well for this application.
- Cover suction and discharge ports with duct tape to prevent any foreign matter from falling into pump.
- Cover pump and engine with plastic covering or equivalent and store in a clean, dry place.

TOWING GUIDELINES

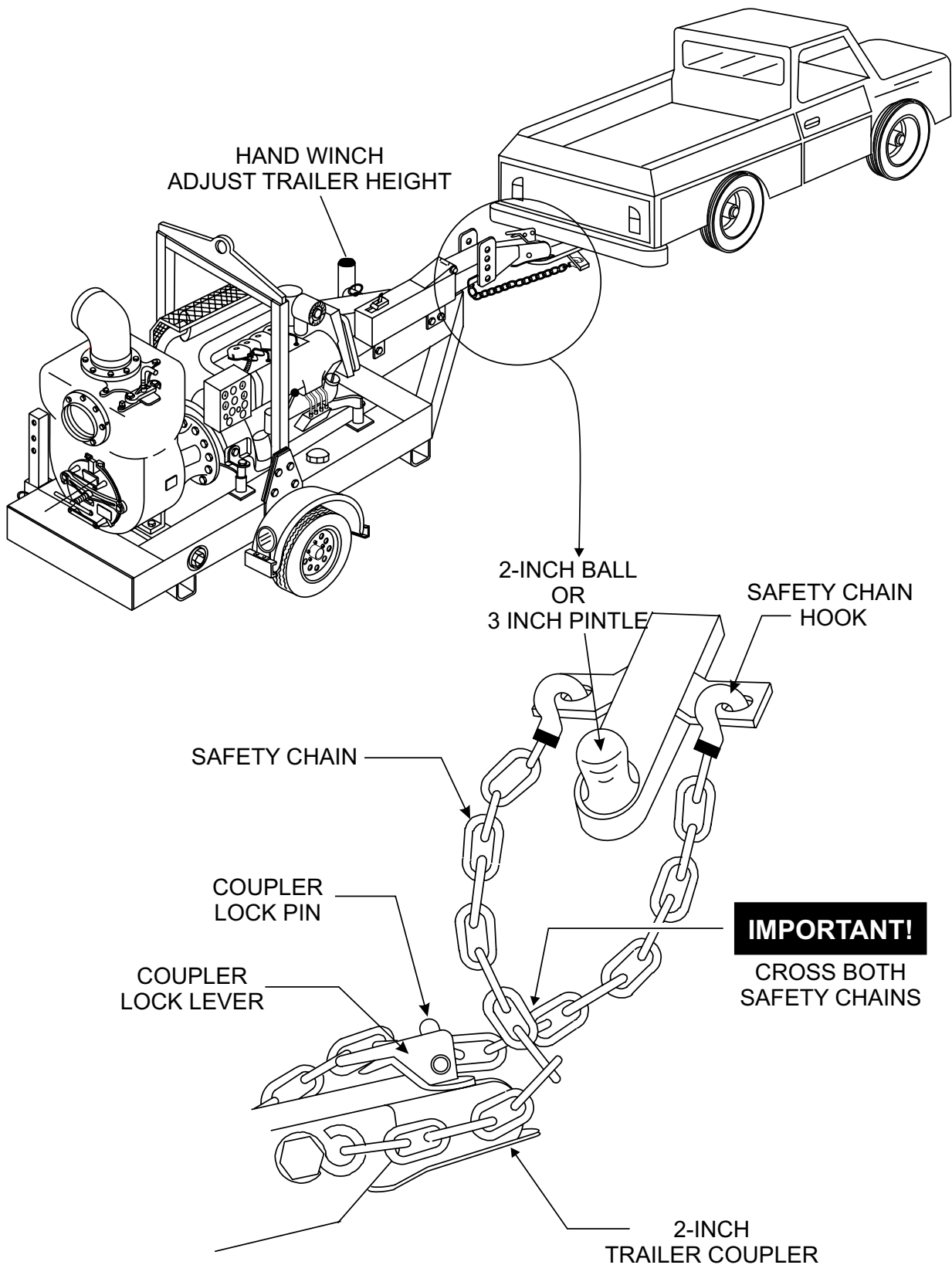

Figure 52. Safety Chains/Trailer Coupler Hookup

TRAILER GUIDELINES

The following guidelines are intended to assist the operator in the operation and handling of a trailer.

Safety precautions should be followed at all times when operating a trailer. Failure to read, understand and follow the safety guidelines could result in injury to yourself and others. Loss of control of the trailer or tow vehicle can result in death or serious injury.

COMMON CAUSES FOR LOSS OF TRAILER

- Driving too fast for the conditions (maximum speed when towing a trailer is 55 mph).
- Overloading the trailer or loading the trailer unevenly.
- Trailer improperly coupled to the hitch.
- No braking on trailer.
- Not maintaining proper tire pressure.
- Not keeping lug nuts tight.
- Not properly maintaining the trailer structure.
- Ensure machine is towed level to tow vehicle.

TRAILER TOWING GUIDELINES

- Recheck the load tiedowns to make sure the load will not shift during towing.
- Before towing, check coupling, safety chain, safety brake, tires, wheels and lights.
- Check the lug nuts or bolts for tightness.
- Check coupler tightness after towing 50 miles.
- Use your mirrors to verify that you have room to change lanes or pull into traffic.
- Use your turn signals well in advance. Allow plenty of stopping space for your trailer and tow vehicle.
- Allow plenty of stopping space for your trailer and tow vehicle.
- **DO NOT** drive so fast that the trailer begins to sway due to speed.
- Allow plenty of room for passing. A rule of thumb is that the passing distance with a trailer is 4 times the passing distance without the trailer.

- Shift your automatic transmission into a lower gear for city driving.
- **ALWAYS** use lower gears for climbing and descending grades.
- **DO NOT** ride the brakes while descending grades, they may get so hot that they stop working. Then you will potentially have a runaway tow vehicle and trailer.
- To conserve fuel, don't use full throttle to climb a hill. Instead, build speed on the approach.
- Slow down for bumps in the road. Take your foot off the brake when crossing the bump.
- **DO NOT** brake while in a curve unless absolutely necessary. Instead, slow down before you enter the curve and power through the curve. This way, the towing vehicle remains in charge.
- **DO NOT** apply the brakes to correct extreme trailer swaying. Continued pulling of the trailer, and even slight acceleration, will provide a stabilizing force.
- Anticipate the trailer "swaying." Swaying is the trailer reaction to the air pressure wave caused by passing trucks and buses. Continued pulling of the trailer provides a stabilizing force to correct swaying. **DO NOT** apply the brakes to correct trailer swaying.
- Use lower gear when driving down steep or long grades. Use the engine and transmission as a brake. Do not ride the brakes, as they can overheat and become ineffective.
- Be aware of your trailer height, especially when approaching roofed areas and around trees.
- Make regular stops, about once each hour. Confirm that:
 - Coupler is secure to the hitch and is locked.
 - Electrical connectors are secure.
 - There is appropriate slack in the safety chains.
 - There is appropriate slack in the breakaway switch pullpin cable.
 - Tires are not visibly low on pressure.

TRAILER GUIDELINES

DRIVING CONDITIONS

When towing a trailer, you will have decreased acceleration, increased stopping distance, and increased turning radius (which means you must make wider turns to keep from hitting curbs, vehicles, and anything else that is on the inside corner). In addition, you will need a longer distance to pass, due to slower acceleration and increased length.

- Be alert for slippery conditions. You are more likely to be affected by slippery road surfaces when driving a tow vehicle with a trailer, than driving a tow vehicle without a trailer.
- Check rearview mirrors frequently to observe the trailer and traffic.
- **NEVER** drive faster than what is safe.

WARNING

Driving too fast for severe road conditions can result in loss of control and cause death or serious injury.

Decrease your speed as road, weather, and lighting conditions deteriorate.

Always check for local trailer tow speed limits in your area.

WARNING

Do not transport people on the trailer. The transport of people puts their lives at risk and may be illegal.

COUPLING TO THE TOW VEHICLE

Follow all of the safety precautions and instructions in this manual to ensure safety of persons, equipment, and satisfactory life of the trailer. Always use an adequate tow vehicle and hitch. If the vehicle or hitch is not properly selected and matched to the Gross Vehicle Weight Rating (GVWR) of your trailer, you can cause an accident that could lead to death or serious injury.

If you already have a tow vehicle, know your vehicle tow rating and make certain the trailer's rated capacity is less than or equal to the tow vehicle's rated towing capacity. If you already have (or plan to buy) a trailer, make certain that the tow rating of the tow vehicle is equal to or greater than that of the trailer.

The trailer VIN tag contains the critical safety information

for the use of your trailer. Again, be sure your hitch and tow vehicle are rated for the Gross Vehicle Weight Rating of your trailer.

WARNING

Proper selection and condition of the coupler and hitch are essential to safely towing your trailer. A loss of coupling may result in death or serious injury.

- Be sure the hitch load rating is equal to or greater than the load rating of the coupler.
- Be sure the hitch size matches the coupler size.
- Observe the hitch for wear, corrosion and cracks before coupling. Replace worn, corroded or cracked hitch components before coupling the trailer to the tow vehicle.
- Be sure the hitch components are tight before coupling the trailer to the tow vehicle.

WARNING

An improperly coupled trailer can result in death or serious injury.

DO NOT move the trailer until:

- The coupler is secured and locked to hitch.
- The safety chains are secured to the tow vehicle.
- The trailer jack(s) are fully retracted.

DO NOT tow the trailer on the road until:

- Tires and wheels are checked.
- The trailer brakes are checked.
- The breakaway switch is connected to the tow vehicle.
- The load is secured to the trailer.
- The trailer lights are connected and checked.

WARNING

Use of a hitch with a load rating less than the load rating of the trailer can result in loss of control and may lead to death or serious injury.

Use of a tow vehicle with a towing capacity less than the load rating of the trailer can result in loss of control, and may lead to death or serious injury.

Be sure your hitch and tow vehicle are rated for the Gross Vehicle Weight Rating of your trailer.

TRAILER GUIDELINES

INOPERABLE BRAKES, LIGHTS OR MIRRORS

Be sure that the brakes and all of the lights on your trailer are functioning properly before towing your trailer. Check the trailer taillights by turning on your tow vehicle headlights. Check the trailer brake lights by having someone step on the tow vehicle brake pedal while you look at trailer lights. Do the same thing to check the turn signal lights. See Trailer Wiring Diagram section in this manual.

Standard mirrors usually do not provide adequate visibility for viewing traffic to the sides and rear of a towed trailer. You must provide mirrors that allow you to safely observe approaching traffic.

WARNING

Improper electrical connection between the tow vehicle and the trailer will result in inoperable lights and can lead to collision.

Before each tow, check that the tail lights, brake lights and turn signals work.

TRAILER TOWING TIPS

Driving a vehicle with a trailer in tow is vastly different from driving the same vehicle without a trailer in tow. Acceleration, maneuverability and braking are all diminished with a trailer in tow.

It takes longer to get up to speed, you need more room to turn and pass, and more distance to stop when towing a trailer. You will need to spend time adjusting to the different feel and maneuverability of the tow vehicle with a loaded trailer.

Because of the significant differences in all aspects of maneuverability when towing a trailer, the hazards and risks of injury are also much greater than when driving without a trailer. You are responsible for keeping your vehicle and trailer in control, and for all the damage that is caused if you lose control of your vehicle and trailer.

As you did when learning to drive an automobile, find an open area with little or no traffic for your first practice trailering. Of course, before you start towing the trailer, you must follow all of the instructions for inspection, testing, loading and coupling. Also, before you start towing, adjust the mirrors so you can see the trailer as well as the area to the rear of it.

Drive slowly at first, 5 mph or so, and turn the wheel to get the feel of how the tow vehicle and trailer combination responds. Next, make some right and left hand turns. Watch in your side mirrors to see how the trailer follows the tow vehicle. Turning with a trailer attached requires more room.

Stop the rig a few times from speeds no greater than 10 mph. If your trailer is equipped with brakes, try using different combinations of trailer brake and tow vehicle brake. Note the effect that the trailer brakes have when they are the only brakes used. When properly adjusted, the trailer brakes will come on just before the tow vehicle brakes.

It will take practice to learn how to back up a tow vehicle with a trailer attached. Take it slow. Before backing up, get out of the tow vehicle and look behind the trailer to make sure that there are no obstacles.

Some drivers place their hands at the bottom of the steering wheel, and while the tow vehicle is in reverse, “think” of the hands as being on the top of the wheel. When the hands move to the right (counterclockwise, as you would do to turn the tow vehicle to the left when moving forward), the rear of the trailer moves to the right. Conversely, rotating the steering wheel clockwise with your hands at the bottom of the wheel will move the rear of the trailer to the left while backing up.

If you are towing a bumper hitch rig, be careful not to allow the trailer to turn too much because it will hit the rear of the tow vehicle. To straighten the rig, either pull forward or turn the steering wheel in the opposite direction.

TRAILER VIN TAG

Figure A below is a sample of the Vehicle Identification Number (VIN) Tag which is typically located on the left front of the trailer. See Figure B for location.

MANUFACTURED BY / FABRIQUE PAR:		DATE:	
GVWR / PNBV	KG (LB)		
GAWR (EACH AXLE) / PNBRE (CHAQUE ESSIEU)	KG (LB)	TIRES / PNEUS	
RIMS / JANTES			
COLD INFL. PRESS. / PRESS. DE GONFL. A FROID	KPA (PSI / LPC	<input checked="" type="checkbox"/> SINGLE <input type="checkbox"/> DUAL
THIS VEHICLE CONFORMS TO ALL APPLICABLE U.S. FEDERAL MOTOR VEHICLE SAFETY STANDARDS IN EFFECT ON THE DATE OF MANUFACTURE SHOWN ABOVE. CE VEHICULE CONFORME A TOUTES LES NORMES QUI SONT APPLICABLES EN VERTU DU REGLEMENT SUR LA SECURITE DES VEHICULES AUTOMOBILES DU CANADA EN VIGUEUR A LA DATE DE SA FABRICATION.			
V.I.N. / N.I.E.:		TYPE / TYPE: TRAILER TRA / REM	FD-306 REV A

Figure A. Vehicle VIN Tag

TRAILER GUIDELINES

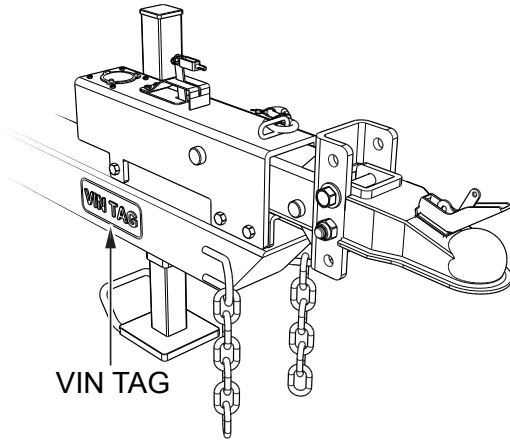

Figure B. Typical VIN Tag Location

The trailer VIN Tag contains the following critical safety information for the use of your trailer.

GAWR: The maximum gross weight that an axle can support. It is the lowest of axle, wheel, or tire rating.

Usually, the tire or wheel rating is lower than the axle rating, and determines GAWR.

GVWR: The maximum allowable gross weight of the trailer and its contents. The gross weight of the trailer includes the weight of the trailer and all of the items within it. GVWR is sometimes referred to as GTWR (Gross Trailer Weight Rating), or MGTW (Maximum Gross Trailer Weight). GVWR, GTWR and MGTW are all the same rating.

The sum total of the GAWR for all trailer axles may be less than the GVWR for the trailer, because some of the trailer load is to be carried by the tow vehicle, rather than by the trailer axle(s). The total weight of the cargo and trailer must not exceed the GVWR, and the load on an axle must not exceed its GAWR.

PSIC: The tire pressure (psi) measured when cold.

VIN: The Vehicle Identification Number.

EMPTY WEIGHT: Some information that comes with the trailer (such as the Manufacturer's Statement of Origin) is not a reliable source for "empty" or "net" weight. The shipping documents list average or standard weights and your trailer may be equipped with options.

To determine the "empty" or "net" weight of your trailer, weigh it on an axle scale. To find the weight of the trailer using an axle scale, you must know the axle weights of your tow vehicle without the trailer coupled. Some of the trailer weight will be transferred from the trailer to the tow vehicle axles, and an axle scale weighs all axles, including the tow vehicle axles.

TOW VEHICLE

The towing hitch attached to your tow vehicle must have a capacity equal to or greater than the load rating of the trailer you intend to tow. The hitch capacity must also be matched to the tow vehicle capacity. Your vehicle dealer can provide and install the proper hitch on your tow vehicle.

SUSPENSION SYSTEM

Sway bars, shock absorbers, heavy duty springs, heavy duty tires and other suspension components may be required to sufficiently tow the trailer and pump.

BRAKE CONTROLLER

For trailers equipped with electric brakes, the electric brake controller is part of the tow vehicle and is essential in the operation of the electric brakes on the trailer. The brake controller is not the same as the safety breakaway brake system that may be equipped on the trailer.

SIDE VIEW MIRRORS

The size of the trailer that is being towed and your state law regulations determine the size of the mirrors. However, some states prohibit extended mirrors on a tow vehicle, except while a trailer is actually being towed. In this situation, detachable extended mirrors are necessary. Check with your dealer or the appropriate state agency for mirror requirements.

HEAVY DUTY FLASHER

A Heavy Duty Flasher is an electrical component that may be required when your trailer turn signal lights are attached to the tow vehicle flasher circuit.

ELECTRICAL CONNECTOR

An Electrical Connector connects the light and brake systems on the trailer to the light and brake controls on the towing vehicle.

TRAILER GUIDELINES

EMERGENCY FLARES AND TRIANGLE REFLECTORS

It is wise to carry these warning devices even if you are not towing a trailer. It is particularly important to have these when towing a trailer because the hazard flashers of your towing vehicle will not operate for as long a period of time when the battery is running both the trailer lights and tow vehicle lights.

SAFETY CHAINS

If the coupler connection comes loose, the safety chains can keep the trailer attached to the tow vehicle. With properly rigged safety chains, it is possible to keep the tongue of the trailer from digging into the road pavement, even if the coupler-to-hitch connection comes apart.

TRAILER LIGHTING AND BRAKING CONNECTOR

A device that connects electrical power from the tow vehicle to the trailer. Electricity is used to turn on brake lights, running lights, and turn signals as required. In addition, if your trailer has a separate braking system, the electrical connector will also supply power to the brakes from the tow vehicle.

BREAKAWAY SYSTEM

If the trailer coupler connection comes loose, the breakaway system can actuate emergency hydraulic brakes depending on the type of actuator on the trailer. The breakaway cable must be rigged to the tow vehicle with appropriate slack that will activate the system if the coupler connection comes loose.

JACKSTAND

A device on the trailer that is used to raise and lower the coupler. The jack is sometimes called the “landing gear” or the “tongue jack”.

COUPLER TYPES

Two types of coupler used with the trailer are discussed below.

- Ball Hitch Coupler
- Pintel Eye Coupler

BALL HITCH COUPLER

A ball hitch coupler (Figure C) connects to a ball that is located on or under the rear bumper of tow vehicle. This system of coupling a trailer to a tow vehicle is sometimes referred to as “bumper pull.”

A ball hitch trailer may be fitted with a tongue jack that can raise and lower the coupler. The tongue jack is mounted to the A-frame (front or tongue) part of the trailer. By rotating the jack handle clockwise, the jack will extend and raise the tongue of the trailer.

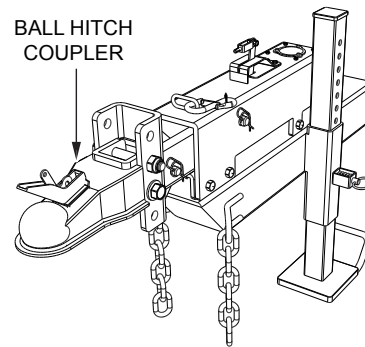

Figure C. Ball Hitch Coupler

Before each tow, coat the ball with a thin layer of automotive bearing grease to reduce wear and ensure proper operation. Check the locking device that secures the coupler to the ball for proper operation.

If you see or feel evidence of wear, such as flat spots, deformations, pitting or corrosion, on the ball or coupler, immediately have your dealer inspect them to determine the proper action to prevent possible failure of the ball and coupler system. All bent or broken coupler parts must be replaced before towing the trailer.

The coupler handle lever must be able to rotate freely and automatically snap into the latched position. Oil the pivot points, sliding surfaces, and spring ends with SAE 30W motor oil. Keep the ball socket and latch mechanism clean. Dirt or contamination can prevent proper operation of the latching mechanism.

The load rating of the coupler and the necessary ball size are listed on the trailer tongue. You must provide a hitch and ball for your tow vehicle where the load rating of the hitch and ball is equal to or greater than that of your trailer.

Also, the ball size must be the same as the coupler size. If the hitch ball is too small, too large, is underrated, is loose

TRAILER GUIDELINES

or is worn, the trailer can come loose from the tow vehicle and may cause death or serious injury.

THE TOW VEHICLE, HITCH AND BALL MUST HAVE A RATED TOWING CAPACITY EQUAL TO OR GREATER THAN THE TRAILER **Gross Vehicle Weight Rating (GVWR)**. IT IS ESSENTIAL THAT THE HITCH BALL BE OF THE SAME SIZE AS THE COUPLER.

The ball size and load rating (capacity) are marked on the ball. Hitch capacity is marked on the hitch.

WARNING

Coupler-to-hitch mismatch can result in uncoupling, leading to death or serious injury.

Be sure the **LOAD RATING** of the hitch ball is equal or greater than the load rating of the coupler.

Be sure the **SIZE** of the hitch ball matches the size of the ball coupler.

WARNING

A worn, cracked or corroded hitch ball can fail while towing and may result in death or serious injury.

Before coupling trailer, inspect the hitch ball for wear, corrosion and cracks.

Replace worn or damaged hitch ball.

WARNING

A loose hitchball nut can result in uncoupling, leading to death or serious injury.

Be sure the hitch ball is tight to the hitch before coupling the trailer.

- Rock the ball to make sure it is tightened to the hitch, and visually check that the hitch ball nut is solid against the lock washer and hitch frame.
- Wipe the inside and outside of the coupler. Clean and visually inspect it for cracks and deformations. Feel the inside of the coupler for worn spots and pits.
- Be sure the coupler is secured tightly to the tongue of the trailer. All coupler fasteners must be visibly solid against the trailer frame.
- The bottom surface of the coupler must be above the top of the hitch ball. Use the tongue jackstand to support

the trailer tongue. Wood or concrete blocks may also be used.

Coupling the Trailer to the Tow Vehicle (Ball Coupler)

- Lubricate the hitch ball and the inside of the coupler with a thin layer of automotive bearing grease.
- Slowly back up the tow vehicle so that the hitch ball is near or aligned under the coupler.
- Using the jackstand at the front of trailer (tongue), turn the jackstand crank handle to raise the trailer. If the ball coupler does not line up with the hitch ball, adjust the position of the tow vehicle.
- Open the coupler locking mechanism. Ball couplers have a locking mechanism with an internal moving piece and an outside handle. In the open position, the coupler is able to drop fully onto the hitch ball.
- Lower the trailer (Figure D) until the coupler fully engages the hitch ball.

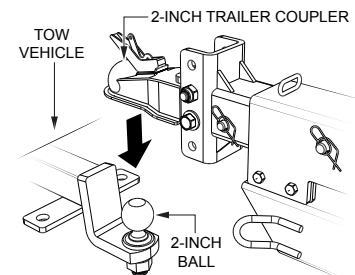

Figure D. Ball Hitch Coupling Mechanism

- Engage the coupler locking mechanism. In the engaged position, the locking mechanism securely holds the coupler to the hitch ball.
- Insert a pin or lock through the hole in the locking mechanism.
- Be sure the coupler is all the way on the hitch ball and the locking mechanism is engaged. A properly engaged locking mechanism will allow the coupler to raise the rear of the tow vehicle. Using the trailer jackstand, verify that you can raise the rear of the tow vehicle by 1 inch after the coupler is locked to the hitch.
- Lower the trailer so that its entire tongue weight is held by the hitch.
- Raise the jackstand to a height where it will not interfere with the road.

TRAILER GUIDELINES

NOTICE

Overloading can damage the tongue jack. **DO NOT** use the tongue jack to raise the tow vehicle more than one inch.

If the coupler cannot be secured to the hitch ball, do not tow the trailer. Call your dealer for assistance. Lower the trailer so that its entire tongue weight is held by the hitch and continue retracting the jack to its fully retracted position.

Attaching Safety Chain

Visually inspect the safety chains and hooks for wear or damage. Replace worn or damaged safety chains and hooks before towing.

Attach the safety chains so that they:

- Cross underneath the coupler. See Figure E.

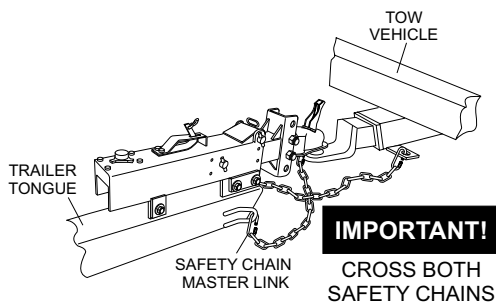

Figure E. Attaching Safety Chain (Ball Hitch)

- Loop around a frame member of the tow vehicle or holes provided in the hitch system (**DO NOT** attach them to an interchangeable part of the hitch assembly).
- Have enough slack to permit tight turns, but not be close to the road surface, so if the trailer uncouples, the safety chains can hold the tongue up above the road

WARNING

Improper rigging of the safety chains can result in loss of control of the trailer and tow vehicle, leading to death or serious injury, if the trailer uncouples from the tow vehicle.

- Fasten chains to frame of tow vehicle. **DO NOT** fasten chains to any part of the hitch unless the hitch has holes or loops specifically for that purpose.
- Cross chains underneath hitch and coupler with enough slack to permit turning and to hold tongue up, if the trailer comes loose.

Breakaway Brake System

If the coupler or hitch fails, a properly connected and working breakaway brake system (Figure F) will apply the hydraulic brakes on the trailer. The safety chains will keep the tow vehicle attached and as the brakes are applied at the trailer's axles, the trailer/tow vehicle combination will come to a controlled stop.

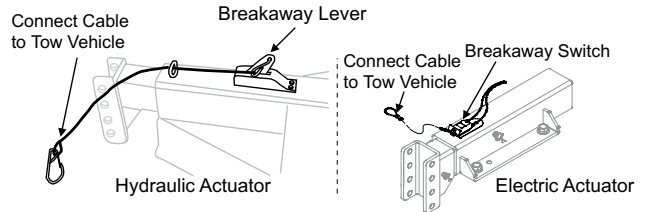

Figure F. Breakaway Brake System

Breakaway Cable Surge Brake System

The breakaway brake system includes a brake cable connected to the tow vehicle on one end and to the emergency brake lever located on the hydraulic actuator on the other end.

WARNING

- An ineffective breakaway brake system can result in a runaway trailer, leading to death or serious injury, if the coupler or ball hitch fails.
- Connect the breakaway cable to the tow vehicle and **NOT** to the hitch, ball or support.
- Before towing the trailer, test the function of the breakaway brake system. If the breakaway brake system is not working, **DO NOT** tow the trailer. Have it serviced or repaired.

NOTICE

DO NOT tow the trailer with the breakaway brake system ON because the brakes will overheat which can result in permanent brake failure.

NOTICE

Replace the breakaway brake battery (if equipped) at intervals specified by manufacturer.

TRAILER GUIDELINES

Connecting Trailer Lights

Connect the trailer lights to the tow vehicle's electrical system using the electric connectors at the front of the trailer (tongue). Refer to the wiring diagram shown in the trailer wiring diagram section of this manual. Before towing the trailer check for the following:

- Running lights (turn on tow vehicle headlights).
- Brake Lights (step on tow vehicle brake pedal).
- Backup Lights (place tow vehicle gear shift in reverse).
- Turn Signals (activate tow vehicle directional signal lever).

WARNING

Improper electrical connection between the tow vehicle and the trailer will result in inoperable lights and electric brakes, and can lead to collision.

Before each tow:

- Check that the taillights, brake lights and turn signals work.
- Check that the electric brakes work by operating the brake controller inside the tow vehicle.

Uncoupling the Ball Hitch

Follow these steps to uncouple ball hitch from tow vehicle:

- Block trailer tires to prevent the trailer from rolling, before jacking the trailer up.
- Disconnect the electrical connector.
- Disconnect the breakaway brake switch cable. Promptly replace the pullpin in the switchbox.
- Before extending jackstand, make certain the ground surface below the jackstand foot will support the tongue load.
- Rotate the jackstand handle (or crank) clockwise. This will slowly extend the jack and transfer the weight of the trailer tongue to the jack.

PINTLE HITCH COUPLER

A pintle eye coupler (Figure G) connects to a pintle-hook hitch that is located on or under the rear bumper of the tow vehicle. This system of coupling a trailer to a tow vehicle is sometimes referred to as a "lunette eye, tow ring or G.I. hitch."

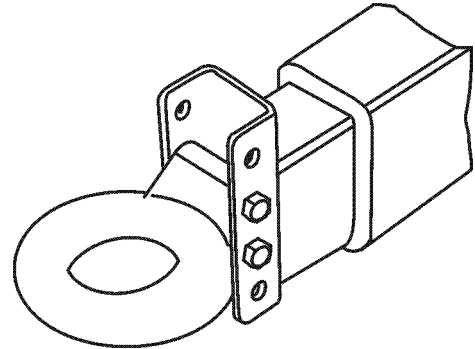

Figure G. Pintle Hitch Coupler

A pintle hitch trailer may be fitted with a tongue jackstand that can raise and lower the coupler. The tongue jack is mounted to the A-frame (front or tongue) part of the trailer. By rotating the jack handle clockwise, the jack will extend and raise the tongue of the trailer.

The load rating of the coupler and the necessary pintle hitch size are listed on the trailer tongue. You must provide a pintle hitch and pintle coupler for your tow vehicle, where the load rating of the pintle hitch and pintle coupler is equal to or greater than that of your trailer.

Also, the pintle hitch size must be the same as the pintle coupler size. If the hitch is too small, too large, underrated, loose or worn, the trailer can come loose from the tow vehicle, and may cause death or serious injury.

Pintle Coupler and Pintle Hook

Before each tow, check the locking device that secures the coupler to the pintle hook assembly.

The pintle hook lever must be able to operate freely and automatically snap into place into the latched position. Lightly oil the pivot points and sliding surfaces with SAE30W motor oil to prevent rust and help ensure proper operation of the latching mechanism.

If you see or feel evidence of wear, such as flat spots, deformations, pitting or corrosion, on the pintle hook or coupler, immediately have your dealer inspect them to determine the proper action to prevent possible failure of

TRAILER GUIDELINES

the ball and coupler system. All bent or broken coupler parts must be replaced before towing the trailer.

THE TOW VEHICLE, PINTLE HITCH AND PINTLE COUPLER MUST HAVE A RATED TOWING CAPACITY EQUAL TO OR GREATER THAN THE TRAILER **Gross Vehicle Weight Rating (GVWR)**.

IT IS ESSENTIAL THAT THE PINTLE HITCH BE OF THE SAME SIZE AS THE PINTLE COUPLER.

The coupler size and load rating (capacity) are marked on the coupler. Hitch capacity is marked on the hitch.

WARNING

Coupler-to-hitch mismatch can result in uncoupling, leading to death or serious injury.

Be sure the **LOAD RATING** of the pintle hitch hook is equal or greater than the load rating of the pintle eye coupler.

Be sure the **SIZE** of the pintle hitch hook matches the size of the pintle eye coupler.

WARNING

A worn, cracked or corroded pintle hitch hook can fail while towing, and may result in death or serious injury.

Before coupling trailer, inspect the pintle hitch hook for wear, corrosion and cracks.

Replace worn or damaged pintle hitch hook.

- Rock the pintle eye coupler to make sure it is secured tightly to the hitch.
- Wipe the inside and outside of the pintle coupler. Clean and inspect it visually for cracks and deformations. Feel the inside of the coupler for worn spots and pits.
- Be sure the coupler is secured tightly to the tongue of the trailer. All coupler fasteners must be visibly solid against the trailer frame.
- Raise the bottom surface of the coupler to be above the top of the pintle hitch hook. Use the tongue jackstand to support the trailer tongue. Wood or concrete blocks may also be used.

WARNING

A defective pintle hitch not properly fastened can result in uncoupling, leading to death or serious injury.

Be sure the pintle hook is securely tightened to the tow vehicle before coupling the trailer.

Coupling Trailer to Tow Vehicle (Pintle Coupler)

- Slowly back up the tow vehicle so that the pintle hitch hook is near or aligned under the pintle eye ring coupler.
- Using the jackstand at the front of trailer (tongue), turn the jackstand crank handle to raise the trailer. If the pintle eye coupler does not line up with the pintle hitch hook, adjust the position of the tow vehicle.
- **OPEN** the pintle hook locking mechanism (Figure H). Place the hook inside the eye coupler. **CLOSE** the pintle hook mechanism.

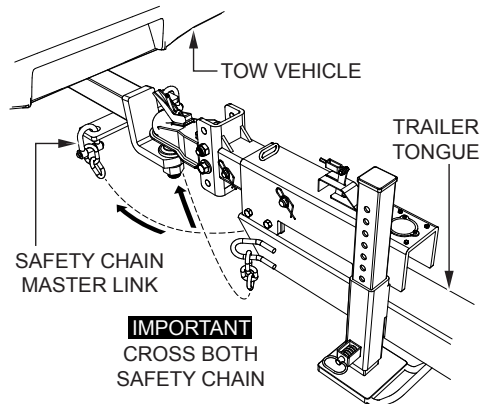

Figure H. Attaching Safety Chain (Pintle Hitch)

- Insert a pin or lock through the hole in the locking mechanism.
- Be sure the pintle hook is inserted completely through the eye ring and the locking mechanism is engaged. A properly engaged locking mechanism will allow the coupler to raise the rear of the tow vehicle. Using the trailer jack, test to see that you can raise the rear of the tow vehicle by 1-inch after the coupler is locked to the hitch.
- Lower the trailer so that its entire tongue weight is held by the hitch.
- Raise the jackstand to a height where it will not interfere with the road.

TIRE SAFETY

Unsafe Tires, Lug Nuts or Wheels

Trailer tires and wheels are more likely to fail than car tires and wheels because they carry a heavier load. Therefore, it is essential to inspect the trailer tires before each tow.

If a tire has a bald spot, bulge, cuts, is showing any cords, or is cracked, replace the tire before towing. If a tire has uneven tread wear, take the trailer to a dealer service center for diagnosis.

Uneven tread wear can be caused by tire imbalance, axle misalignment or incorrect inflation.

Tires with too little tread will not provide adequate tracking on wet roadways and can result in loss of control, leading to death or serious injury.

Improper tire pressure causes an unstable trailer and can result in a tire blowout and loss of control. Therefore, before each tow you must also check the tire pressure. Tire pressure must be checked when tires are cold.

Allow 3 hours cool-down after driving as much as 1 mile at 40 mph before checking tire pressure. Trailer tires will be inflated to higher pressures than passenger vehicle tires.

Since trailer wheels and lug nuts (or bolts) are subjected to greater side loads than automobile wheels, they are more prone to loosen. Before each tow, check to make sure they are tight.

The proper tightness (torque) for lug nuts is listed in the lug nut tightening section of this manual. Use a torque wrench to tighten the lug nuts. If you do not have a torque wrench, use a lug wrench (from your tow vehicle) and tighten the nuts as much as you can. Then have a service garage or trailer dealer tighten the lug nuts to the proper torque.

WARNING

Metal creep between the wheel rim and lug nuts will cause rim to loosen and could result in a wheel coming off, leading to death or serious injury.

Tighten lug nuts before each tow.

Lug nuts are also prone to loosen after first being assembled. When driving a new trailer (or after wheels have been remounted), check to make sure they are tight after the first 10, 25 and 50 miles of driving and before each tow thereafter.

Failure to perform this check can result in a wheel parting from the trailer and a crash, leading to death or serious injury.

WARNING

Lug nuts are prone to loosen after initial installation, which can lead to death or serious injury.

Check lug nuts for tightness on a new trailer or when wheel(s) have been remounted after the first 10, 25 and 50 miles of driving.

WARNING

Improper lug nut torque can cause a wheel parting from the trailer, leading to death or serious injury.

Be sure lug nuts are tight before each tow.

WARNING

Improper tire pressure can result in a blowout and loss of control, which can lead to death or serious injury.

Be sure tires are inflated to pressure indicated on side wall before towing trailer.

Determining Load Limit of Trailer

Determining the load limits of a trailer includes more than understanding the load limits of the tires alone. On all trailers there is a Federal certification/VIN label that is located on the forward half of the left (road) side of the unit. This certification/VIN label will indicate the trailer's Gross Vehicle Weight Rating (GVWR). This is the most weight the fully loaded trailer can weigh. It will also provide the Gross Axle Weight Rating (GAWR). This is the most the axle can weigh.

TRAILER GUIDELINES

There is a vehicle placard (Figure I) located in the same location as the certification label described above. This placard provides tire and loading information. In addition, this placard will show a statement regarding maximum cargo capacity.

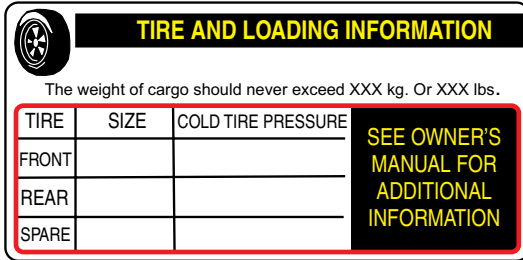

Figure I. Trailer Tire Placard

If additional work items (hoses, tools, clamps etc.) are going to be added to the trailer, be sure they are distributed evenly to prevent overloading front to back and side to side. Heavy items should be placed low and as close to the axle positions as reasonable. Too many items on one side may overload a tire.

Excessive loads and/or underinflation cause tire overloading and, as a result, abnormal tire flexing occurs. This situation can generate an excessive amount of heat within the tire. Excessive heat may lead to tire failure. It is the air pressure that enables a tire to support the load, so proper inflation is critical. The proper air pressure may be found on the certification/VIN label and/or on the Tire and Loading Information placard. This value should never exceed the maximum cold inflation pressure stamped on the tire.

Perform the following steps to determine the load limit of your trailer.

Step 1.

Locate the statement, “The weight of cargo should never exceed XXX kg or XXX lbs.,” on your vehicle’s Tire and Loading Information placard (Figure I). This value equals the available amount of equipment load capacity.

Step 2.

Determine the weight of the equipment being loaded on the tow vehicle. That weight may not safely exceed the available equipment load capacity. The trailer’s Tire Information Placard is attached adjacent to or near the trailer’s VIN (Certification) label at the left front of the trailer (See Figure I).

Determining Load Limit of Tow Vehicle

Step 1.

Locate the statement, “The combined weight of occupants and cargo should never exceed XXX lbs.,” on your vehicle’s placard.

Step 2.

Determine the combined weight of the driver and passengers who will be riding in your vehicle.

Step 3.

Subtract the combined weight of the driver and passengers from XXX kilograms or XXX pounds.

Step 4.

The resulting figure equals the available amount of cargo and luggage capacity. For example, if the “XXX” amount equals 1400 lbs. and there will be five 150 lb. passengers in your vehicle, the amount of available cargo and luggage capacity is 650 lbs. (1400-750 (5 x 150) = 650 lbs.).

Step 5.

Determine the combined weight of luggage and cargo being loaded on the vehicle. That weight may not safely exceed the available cargo and luggage capacity calculated in Step 4.

If your vehicle will be towing a trailer, load from your trailer will be transferred to your vehicle. Consult the tow vehicle’s manual to determine how this weight transfer reduces the available cargo and luggage capacity of your vehicle.

Studies of tire safety show that maintaining proper tire pressure, observing tire and vehicle load limits (not carrying more weight in your vehicle than your tires or vehicle can safely handle), avoiding road hazards and inspecting tires for cuts, slashes and other irregularities are the most important things you can do to avoid tire failure, such as tread separation or blowout and flat tires. These actions, along with other care and maintenance activities, can also:

- Improve vehicle handling.
- Help protect you and others from avoidable breakdowns and accidents.
- Improve fuel economy.
- Increase the tire life.

TRAILER GUIDELINES

Use the information contained in this section to make tire safety a regular part of your vehicle maintenance routine. Recognize that the time you spend is minimal compared with the inconvenience and safety consequences of a flat tire or other tire failure.

TIRE FUNDAMENTALS

Federal law requires tire manufacturers to place standardized information on the sidewall of all tires (Figure J). This information identifies and describes the fundamental characteristics of the tire and also provides a tire identification number for safety standard certification and in case of a recall.

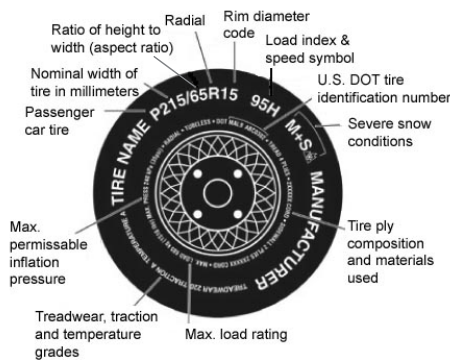

Figure J. Standard Tire Sidewall Information

P: The “P” indicates the tire is for passenger vehicles.

Next number: This three-digit number gives the width in millimeters of the tire from sidewall edge to sidewall edge. In general, the larger the number, the wider the tire.

Next number: This two-digit number, known as the aspect ratio, gives the tire’s ratio of height to width. Numbers of 70 or lower indicate a short sidewall for improved steering response and better overall handling on dry pavement.

P: The “R” stands for radial. Radial ply construction of tires has been the industry standard for the past 20 years.

Next number: This two-digit number is the wheel or rim diameter in inches. If you change your wheel size, you will have to purchase new tires to match the new wheel diameter.

Next number: This two- or three-digit number is the tire’s load index. It is a measurement of how much weight each tire can support. You may find this information in your owner’s manual. If not, contact a local tire dealer. *Note:* You may not find this information on all tires because it is not required by law.

M+S: The “M+S” or “M/S” indicates that the tire has some mud and snow capability. Most radial tires have these markings; hence, they have some mud and snow capability.

Speed Rating: The speed rating denotes the speed at which a tire is designed to be driven for extended periods of time. The ratings range from 99 miles per hour (mph) to 186 mph. These ratings are listed in Table A. *Note:* You may not find this information on all tires because it is not required by law.

Letter Rating	Speed Rating
Q	99 mph
R	106 mph
S	112 mph
T	118 mph
U	124 mph
H	130 mph
V	149 mph
W	168* mph
Y	186* mph

U.S. DOT Tire Identification Number: This begins with the letters “DOT” and indicates that the tire meets all federal standards. The next two numbers or letters are the plant code where it was manufactured, and the last four numbers represent the week and year the tire was built. For example, the numbers 3197 means the 31st week of 1997. The other numbers are marketing codes used at the manufacturer’s discretion. This information is used to contact consumers if a tire defect requires a recall.

Tire Ply Composition and Materials Used: The number of plies indicates the number of layers of rubber-coated fabric in the tire. In general, the greater the number of plies, the more weight a tire can support. Tire manufacturers also must indicate the materials in the tire, which include steel, nylon, polyester, and others.

Maximum Load Rating: This number indicates the maximum load in kilograms and pounds that can be carried by the tire.

Maximum Permissible Inflation Pressure: This number is the greatest amount of air pressure that should ever be put in the tire under normal driving conditions.

TRAILER GUIDELINES

Uniform Tire Quality Grading Standards (UTQGS)

Treadwear Number: This number indicates the tire's wear rate. The higher the treadwear number is, the longer it should take for the tread to wear down. For example, a tire graded 400 should last twice as long as a tire graded 200.

Traction Letter: This letter indicates a tire's ability to stop on wet pavement. A higher graded tire should allow you to stop your car on wet roads in a shorter distance than a tire with a lower grade. Traction is graded from highest to lowest as "AA," "A," "B," and "C".

Temperature Letter: This letter indicates a tire's resistance to heat. The temperature grade is for a tire that is inflated properly and not overloaded. Excessive speed, underinflation or excessive loading, either separately or in combination, can cause heat build-up and possible tire failure. From highest to lowest, a tire's resistance to heat is graded as "A," "B", or "C".

Refer to Figure K for additional tire information for light trucks.

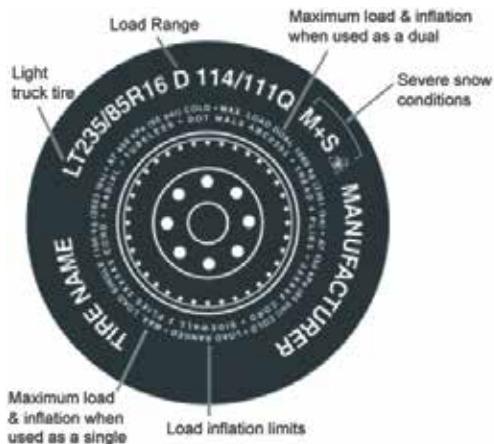

Figure K. UTQGS Tire Information

Tires for light trucks have other markings besides those found on the sidewalls of passenger tires.

LT: The "LT" indicates the tire is for light trucks or trailers.

ST: An "ST" is an indication the tire is for trailer use only.

Max. Load Dual kg (lbs) at kPa (psi) Cold: This information indicates the maximum load and tire pressure when the tire is used as a dual, that is, when four tires are put on each rear axle (a total of six or more tires on the vehicle).

Max. Load Single kg (lbs) at kPa (psi) Cold: This information indicates the maximum load and tire pressure when the tire is used as a single.

Load Range: This information identifies the tire's load-carrying capabilities and its inflation limits.

Tire Safety Tips

- Slow down if you have to go over a pothole or other object in the road.
- **DO NOT** run over curbs or other foreign objects in the roadway, and try not to strike the curb when parking.
- Check tire inflation pressure weekly during use to insure the maximum tire life and tread wear.
- **DO NOT** bleed air from tires when they are hot.
- Inspect tires for uneven wear patterns on the tread, cracks, foreign objects, or other signs of wear or trauma.
- Remove bits of glass and foreign objects wedged in the tread.
- Make sure your tire valves have valve caps.
- **ALWAYS** check tire pressure on tow vehicle and trailer before towing. Check tire pressure at least once a month.
- **DO NOT** overload tow vehicle. Check the tire information and loading placard for safe allowable tire loading conditions.

Tire Repair







The proper repair of a punctured tire requires a plug for the hole and a patch for the area inside the tire that surrounds the puncture hole. Punctures through the tread can be repaired if they are not too large, but punctures to the sidewall should not be repaired. Tires must be removed from the rim to be properly inspected before being plugged and patched.

Replacing Worn or Damaged Tires

Replace the tire before towing the trailer if the tire treads have less than 1/16 inch depth or the telltale bands are visible. Check inflation pressure weekly during use to insure the maximum tire life and tread wear. A bubble, cut or bulge in a side wall can result in a tire blowout. Inspect both side walls of each tire for any bubble, cut or bulge; and replace a damaged tire before towing the trailer.

TRAILER GUIDELINES

Table B below will help pinpoint the causes and solutions of tire wear problems.

Table B. Tire Wear Troubleshooting			
Wear Pattern		Cause	Solution
	Center Wear	Over inflation.	Adjust pressure to particular load per tire manufacturer.
	Edge Wear	Under inflation.	Adjust pressure to particular load per tire manufacturer.
	Side Wear	Loss of camber or overloading.	Make sure load does not exceed axle rating. Align wheels.
	Toe Wear	Incorrect toe-in.	Align wheels.
	Cupping	Out-of-balance.	Check bearing adjustment and balance tires.
	Flat Spots	Wheel lockup and tire skidding.	Avoid sudden stops when possible and adjust brakes.

WARNING



ALWAYS wear safety glasses when removing or installing force fitted parts. **DO NOT** attempt to repair or modify a wheel. **DO NOT** install an inner-tube to correct a leak through through the rim. If the rim is cracked, the air pressure in the inner tube may cause pieces of the rim to explode (break off) with great force and cause serious eye or bodily injury.

Wheel Rims

If the trailer has been struck, or impacted, on or near the wheels, or if the trailer has struck a curb, inspect the rims for damage (i.e. being out of round); and replace any damaged wheel. Inspect the wheels for damage every year, even if no obvious impact has occurred.

Wheels, Bearings and Lug Nuts

A loose, worn or damaged wheel bearing is the most common cause of brakes that grab.

To check wheel bearings, jack trailer and check wheels for side-to-side looseness. If the wheels are loose, or spin with a wobble, the bearings must be serviced or replaced. Check inflation pressure weekly during use to insure the maximum tire life and tread wear. Most trailer axles are built with sealed bearings that are not serviceable. Sealed bearings must be replaced as complete units.

NOTICE

NEVER use an pneumatic air gun to tighten wheel lug nuts.

Over-tightening lug nuts will result in breaking the studs or permanently deforming the mounting stud holes in the wheels.

WARNING

Lug nuts are prone to loosen after initial installation, which can lead to death or serious injury. Check all wheel lug nuts periodically.

Lug Nut Torque Requirements

It is extremely important to apply and maintain proper wheel mounting torque on the trailer. Be sure to use only the fasteners matched to the cone angle of the wheel. Proper procedure for attachment of the wheels is as follows:

1. Start all wheel lug nuts by hand.
2. Torque all lug nuts in sequence. See Figure L. **DO NOT** torque the wheel lug nuts all the way down. Tighten each lug nut in 3 separate passes as defined by Table C.
3. Check to see if the lug nuts are tight after the first 10, 25 and 50 miles of driving and before each tow thereafter

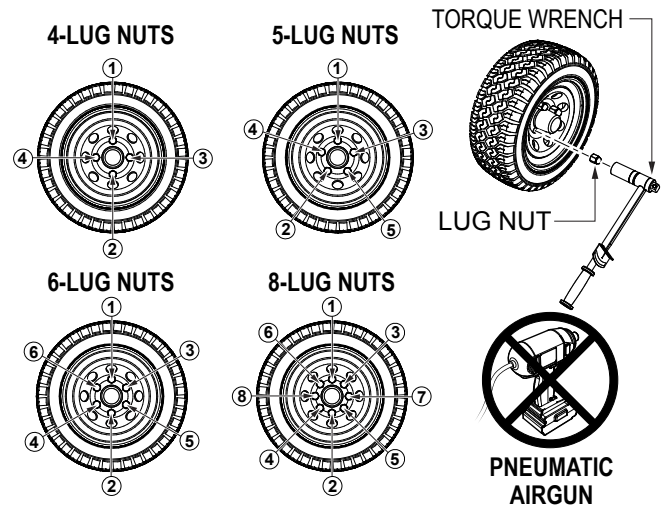

Figure L. Wheel Lug Nuts Tightening Sequence

TRAILER GUIDELINES

Table C. Tire Torque Requirements			
Wheel Size	First Pass FT-LBS	Second Pass FT-LBS	Third Pass FT-LBS
12"	20-25	35-40	50-65
13"	20-25	35-40	50-65
14"	20-25	50-60	90-120
15"	20-25	50-60	90-120
16"	20-25	50-60	90-120

Replace any broken or burned-out lamps as necessary. Check the wire harness for cuts, fraying or other damage. If it needs replacing, contact your dealer.

⚠ WARNING

Improper operating taillights, stoplights and turn signals can cause collisions.

Check all lights before each tow.

Lights and Signals

Before each tow, check the trailer taillights, stoplights, turn signals and any clearance lights for proper operation.

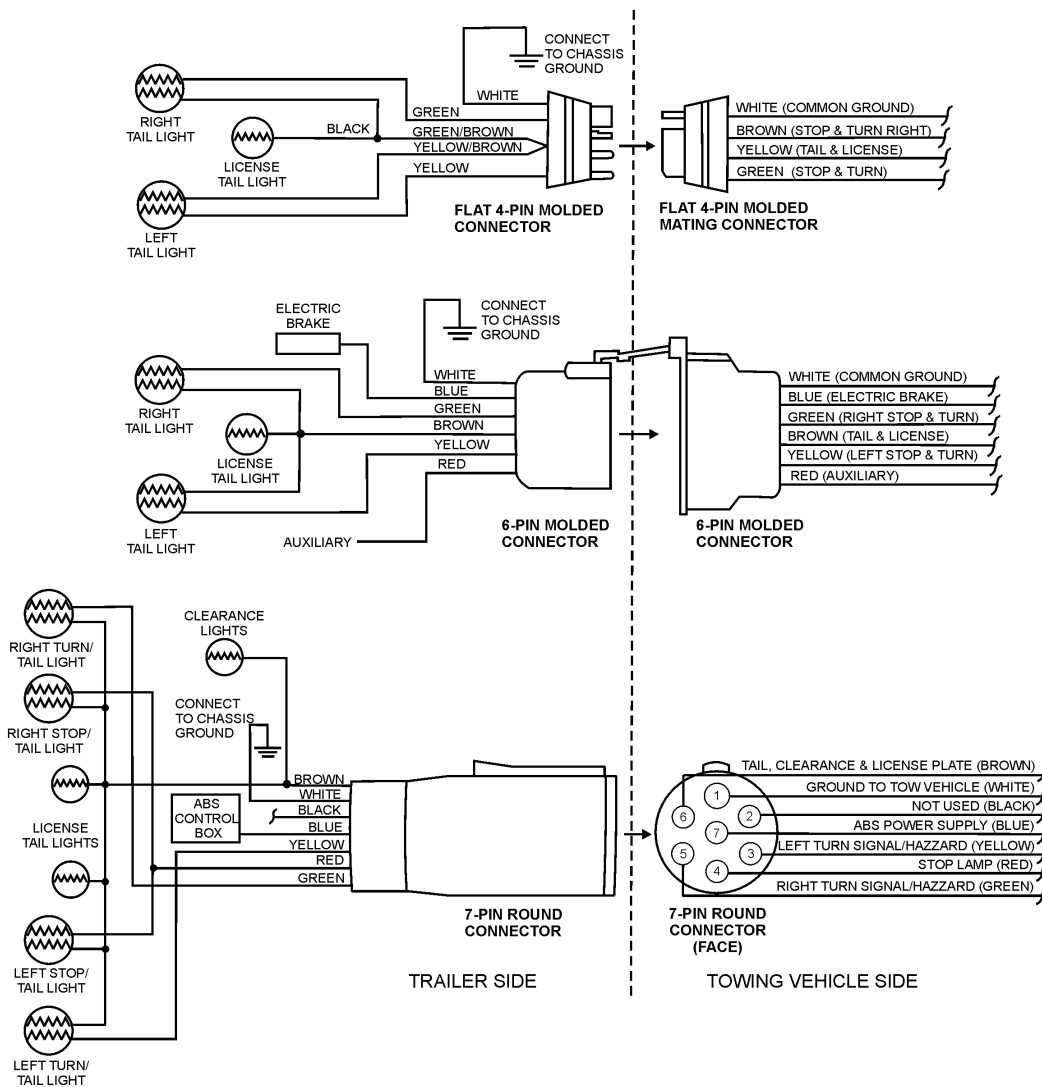

Figure M. Trailer to Tow Vehicle Wiring Diagram

TROUBLESHOOTING

Troubleshooting (Trash Pump)		
Symptom	Possible Problem	Solution
Pump does not prime.	Not enough priming water in the housing?	Add water.
	Engine speed too low?	Increase throttle.
	Strainer plugged?	Clean strainer.
	Suction hose damaged?	Replace or repair hose, and clamps.
	Air leak at suction port?	Check that fittings are tight and properly sealed.
	Pump is located too high above water line?	Move pump closer to water.
	Debris collecting in pump housing?	Clean pump housing.
	Too much distance between impeller and volute?	Adjust clearance by adding gaskets or replace impeller. .010 - 020 inch (0.25 - 0.51 mm)
	Water leaking out sight glass?	Check condition of mechanical seal.
Pump takes in water, little or no discharge.	Engine speed too low?	Increase throttle speed.
	Suction strainer partially plugged?	Clean strainer.
	Impeller/Volute worn?	Adjust clearance or replace impeller/volute.
Suction hose leaks at inlet.	Fittings/clamps are not sealed properly?	Tighten, replace or add clamp. (Keep extra seals on pump).
	Hose diameter is too large?	Use smaller diameter hose or replace hose.
Discharge does not stay on coupling.	Pressure too high?	Check pressure, add additional clamp.
	Hose kinked or end blocked?	Check hose.
Engine is locked or slow to start.	Impeller jammed or blocked?	Open pump cover and clean dirt and debris from inside housing.
	Impeller and wear plate binding?	Inspect for clearance .010 - 020 inch (0.25 - 0.51 mm) . Add or delete gaskets.
	Defective engine?	See Engine Owner's Manual.
	Impeller binding to rear adaptor plate?	Adjust clearance by adding or removing shims 0.25 - 0.40 inch (0.64 - 1.02 mm)

TROUBLESHOOTING

Troubleshooting (Engine)		
Symptom	Possible Problem	Solution
Engine will not start or start is delayed, although engine can be turned over. (Check for engine fault code)	No Fuel reaching injection pump?	Add fuel. Check entire fuel system.
	Defective fuel pump?	Replace fuel pump.
	Fuel filter clogged?	Replace fuel filter and clean tank.
	Faulty fuel supply line?	Replace or repair fuel line.
	Compression too low?	Check piston, cylinder and valves. Adjust or repair per engine repair manual.
	Fuel pump not working correctly?	Repair or replace fuel pump.
	Oil pressure too low?	Check engine oil pressure.
	Low starting temperature limit exceeded?	Comply with cold starting instructions and proper oil viscosity.
	Defective battery?	Charge or replace battery.
At low temperatures engine will not start. (Check for engine fault code)	Engine oil too thick?	Refill engine crankcase with correct type of oil for winter environment.
	Defective battery?	Replace battery.
Engine fires but stops soon as starter is switched off. (Check for engine fault code)	Fuel filter blocked?	Replace fuel filter.
	Fuel supply blocked?	Check the entire fuel system.
	Defective fuel pump?	Replace fuel pump.
Engine stops by itself during normal operation. (Check for engine fault code)	Fuel tank empty?	Check fuel gauge. Fill tank with diesel fuel if necessary.
	Fuel filter blocked?	Replace fuel filter.
	Defective fuel pump?	Replace fuel pump.
	Mechanical oil pressure shutdown sensor stops the engine due to low oil?	Add oil. Replace low oil shutdown sensor if necessary.
Low engine power, output and speed. (Check for engine fault code)	Fuel tank empty?	Check fuel gauge. Fill tank with diesel fuel if necessary.
	Fuel filter clogged?	Replace fuel filter.
	Fuel tank venting is inadequate?	Ensure that tank is adequately vented.
	Leaks at pipe unions?	Check threaded pipe unions tape and tighten unions as required.
	Engine oil level too full?	Correct engine oil level.

TROUBLESHOOTING

Troubleshooting (Engine) - continued		
Symptom	Possible Problem	Solution
Low engine power output and low speed, black exhaust smoke. (Check for engine fault code)	Air filter blocked?	Clean or replace air filter.
	Incorrect valve clearances?	Adjust valves per engine specification.
	Malfunction at injector?	See engine manual.
Engine overheats causing shutdown fault. (Check for engine fault code)	Too much oil in engine crankcase?	Drain off engine oil down to uppermark on dipstick.
	Entire cooling air system contaminated/ blocked?	Clean cooling air system and cooling fin areas.
	Fan belt broken or elongated?	Change belt or adjust belt tension.
	Coolant insufficient?	Replenish coolant.
	Radiator net or radiator fin clogged with dust?	Clean net or fin carefully.
	Fan, radiator, or radiator cap defective?	Replace defective part.
	Thermostat defective?	Check thermostat and replace if necessary.
Head gasket defective or water leakage?	Replace parts.	

TROUBLESHOOTING

Troubleshooting (Hydraulic Brakes - Trailers)		
Symptom	Possible Problem	Solution
No brakes	Is the brake line broken or kinked?	Repair or replace.
Weak brakes or brakes pull to one side.	Is the brake lining glazed?	Reburnish or replace
	Is the trailer overloaded?	Correct weight.
	Are the brake drums scored or grooved?	Check machine or replace.
	Is the tire pressure correct?	Inflate all tires equally per manufacturer guidelines.
	Are the tires unmatched on the same axle?	Match tires.
Locking brakes?	Are the brake components loose, bent or broken?	Replace components.
	Are the brake drums out-of-round?	Replace.
Noisy brakes?	Are the correct brake components installed?	Replace and correct.
	Are brakes dusty or dirty?	Clean brakes.
Dragging brakes?	Is the brake lining thickness correct or installed incorrectly?	Install new shoes and linings.
	Is there enough brake fluid or correct fluid?	Fill with dot 4 fluid.

EXPLANATION OF CODE IN REMARKS COLUMN

The following section explains the different symbols and remarks used in the Parts section of this manual. Use the help numbers found on the back page of the manual if there are any questions.

NOTICE

The contents and part numbers listed in the parts section are subject to change **without notice**. Multiquip does not guarantee the availability of the parts listed.

SAMPLE PARTS LIST

NO.	PART NO.	PART NAME	QTY.	REMARKS
1	12345	BOLT	1	INCLUDES ITEMS W/%
2%		WASHER, 1/4 IN.		NOT SOLD SEPARATELY
2%	12347	WASHER, 3/8 IN. ...	1	MQ-45T ONLY
3	12348	HOSE	A/R	MAKE LOCALLY
4	12349	BEARING	1	S/N 2345B AND ABOVE

NO. Column

Unique Symbols — All items with same unique symbol (@, #, +, %, or >) in the number column belong to the same assembly or kit, which is indicated by a note in the “Remarks” column.

Duplicate Item Numbers — Duplicate numbers indicate multiple part numbers, which are in effect for the same general item, such as different size saw blade guards in use or a part that has been updated on newer versions of the same machine.

NOTICE

When ordering a part that has more than one item number listed, check the remarks column for help in determining the proper part to order.

PART NO. Column

Numbers Used — Part numbers can be indicated by a number, a blank entry, or TBD.

TBD (To Be Determined) is generally used to show a part that has not been assigned a formal part number at the time of publication.

A blank entry generally indicates that the item is not sold separately or is not sold by Multiquip. Other entries will be clarified in the “Remarks” Column.

QTY. Column

Numbers Used — Item quantity can be indicated by a number, a blank entry, or A/R.

A/R (As Required) is generally used for hoses or other parts that are sold in bulk and cut to length.

A blank entry generally indicates that the item is not sold separately. Other entries will be clarified in the “Remarks” Column.

REMARKS Column

Some of the most common notes found in the “Remarks” Column are listed below. Other additional notes needed to describe the item can also be shown.

Assembly/Kit — All items on the parts list with the same unique symbol will be included when this item is purchased.

Indicated by:

“INCLUDES ITEMS W/(unique symbol)”

Serial Number Break — Used to list an effective serial number range where a particular part is used.

Indicated by:

“S/N XXXXX AND BELOW”

“S/N XXXX AND ABOVE”

“S/N XXXX TO S/N XXX”

Specific Model Number Use — Indicates that the part is used only with the specific model number or model number variant listed. It can also be used to show a part is NOT used on a specific model or model number variant.

Indicated by:

“XXXXX ONLY”

“NOT USED ON XXXX”

“Make/Obtain Locally” — Indicates that the part can be purchased at any hardware shop or made out of available items. Examples include battery cables, shims, and certain washers and nuts.

“Not Sold Separately” — Indicates that an item cannot be purchased as a separate item and is either part of an assembly/kit that can be purchased, or is not available for sale through Multiquip.

SUGGESTED SPARE PARTS

MQ600H/HTB/HTP TRASH PUMP

1 to 3 units

Qty.	P/N	Description
3	34488	MECHANICAL SEAL
3	511245	SLEEVE, SEAL (SHAFT)
3	34491	GASKET, FRONT COVER
1	511219	IMPELLER
1	511268	WEAR PLATE
1	34489	FLAP VALVE
1	34493	GASKET
1	511259	OIL SEAL
1	34495	GASKET
1	511261	BEARING
1	511262	BEARING
1	511258	SHAFT
1	511236	OIL SEAL
1	34492	GASKET

HATZ 4H50TIC DIESEL ENGINE

1 to 3 units

Qty.	P/N	Description
1	50638000	PRE FUEL FILTER
1	60638100	FUEL FILTER
1	50638300	AIR FILTER, SECONDARY
1	50638200	AIR FILTER, PRIMARY
1	50629401	POLY V-BELT 768
1	60640500	OIL SEPARATOR
1	50628800	OIL FILTER
1	50640500	FILTER, BREATHER LT

NOTICE

Part numbers on this Suggested Spare Parts list may supersede/replace the part numbers shown in the following parts lists.

NAMEPLATE AND DECALS

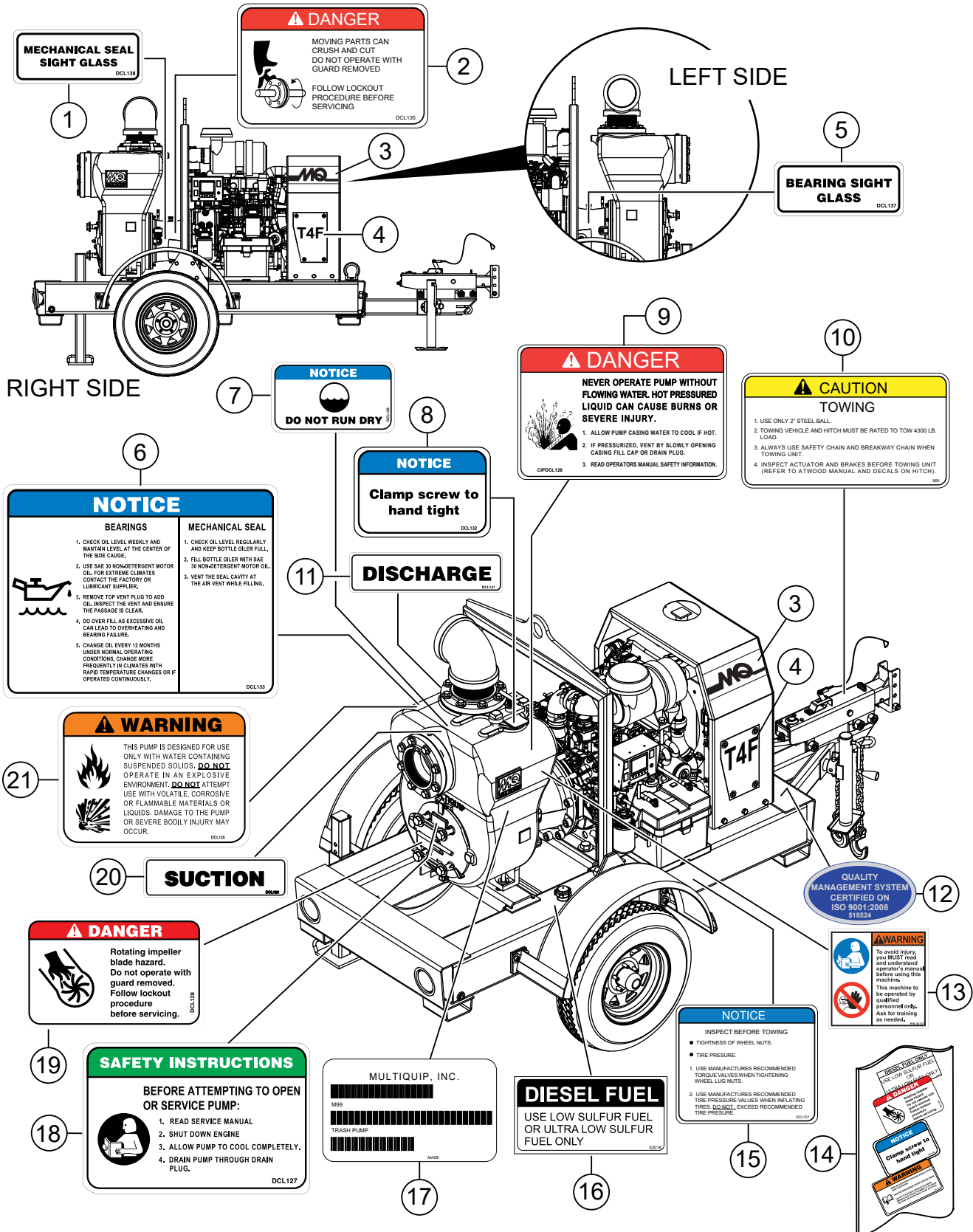

NAMEPLATE AND DECALS

<u>NO.</u>	<u>PART NO.</u>	<u>PART NAME</u>	<u>QTY.</u>	<u>REMARKS</u>
1#	DCL138	DECAL: MEC. SEAL SIGHT GLASS	1	
2#	DCL135	DECAL: WARNING, MOVING PARTS	1	
3#	804938	DECAL: MQ LOGO	2	
4#	804939	DECAL: TIER 4F LOGO	2	
5#	DCL137	DECAL: BEARING SIGHT GLASS	1	
6#	DCL133	DECAL: NOTICE, BEARING/MEC. SEAL	1	
7#	DCL129	DECAL: WARNING, DO NOT RUN DRY	1	
8#	DCL132	DECAL: NOTICE, CLAMP SCREW TIGHT	1	
9#	DCL126	DECAL: WARNING, FILL CAP	1	
10#	EM969	DECAL: TOWING	1	
11#	DCL131	DECAL: DISCHARGE	1	
12#	518524	DECAL: QUALITY MANAGEMENT, ISO	1	
13#	35137	DECAL: READ MANUAL/ASK FOR TRAINING	1	
14	518950	KIT, DECAL.....	1.....	INCLUDES ITEMS W/#
15#	DCL151	DECAL: NOTICE, TIRE PRESSURE/TORQUE	2	
16#	520616	DECAL: DIESEL FUEL, LOW SULFUR	1	
17		DECAL: SERIAL NO.....	1.....	CONTACT MQ PARTS DEPT. W/ MODEL AND S/N
18#	DCL127	DECAL: WARNING, SAFETY INSTRUCTIONS	1	
19#	DCL128	DECAL: WARNING ROTATING IMPELLER	1	
20#	DCL130	DECAL: SUCTION	1	
21#	DCL125	DECAL: WARNING, EXPLOSIVE OPERATION	1	

IMPELLER, CLEANOUT, AND DISCHARGE ASSY.

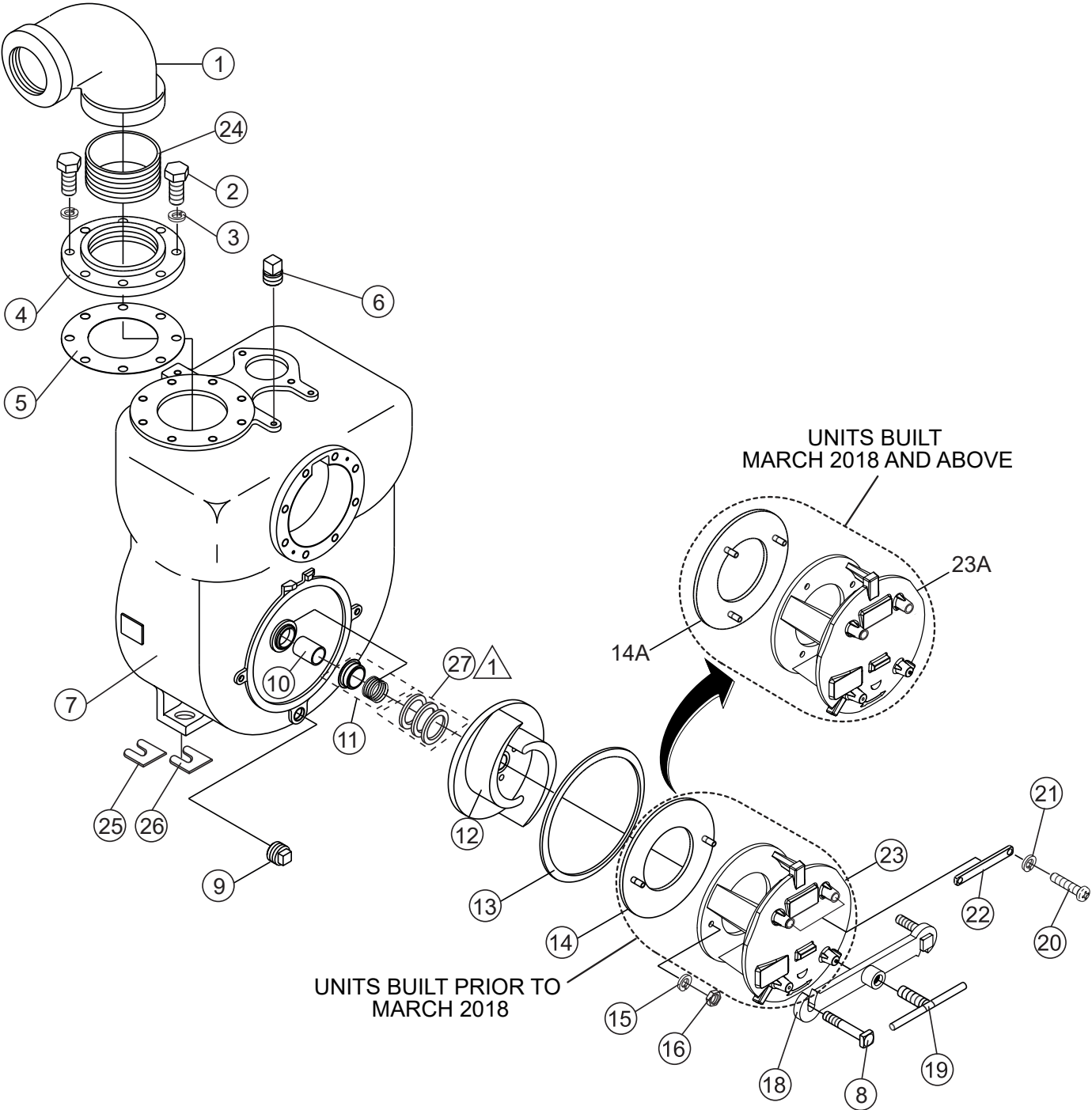

NOTES:

△ 1 ADJUST REAR OF IMPELLER TO ADAPTER COVER
 .025 ~ .040 IN. (0.64 ~ 1.02 MM) USING SHIMS, ITEM 27
 AS REQUIRED.

IMPELLER, CLEANOUT, AND DISCHARGE ASSY.

<u>NO.</u>	<u>PART NO.</u>	<u>PART NAME</u>	<u>QTY.</u>	<u>REMARKS</u>
1	511223	90° ELBOW	1	
2	EM151	HHCS 3/4" X 2", G5.....	8.....	REPLACES P/N 509078
3	492628	WASHER, LOCK 3/4"	8	
4	511225	RETAINER	1	
5	34496	GASKET	1	
6	511220	PIPE NIPPLE	1	
7	511217	MAIN HOUSING	1	
8	511832	MACHINE BOLT	2	
9	491214	DRAIN PLUG, 1"	1	
10	511245	SLEEVE, SEAL (SHAFT)	1	
11	34488	MECHANICAL SEAL ASSY.	1	
12	511219	IMPELLER	1	
13	34491	GASKET	1	
14	511268	WEAR PLATE (2 STUD).....	1.....	S/N J030138 AND BELOW
14A	521940	WEAR PLATE (3 STUD).....	1.....	S/N J030139 AND ABOVE
15	511302	WASHER, LOCK	2	
16	508704	NUT	2	
18	511276	RETAINING BAR	1	
19	511837	LOCK BOLT, FRONT COVER	1	
20	011208025	BOLT M8X25, G8.....	4.....	REPLACES P/N 508342
21	030208200	WASHER, LOCK M8.....	4.....	REPLACES P/N 506597
22	511308	HANDLE	2	
23	511272	FRONT COVER (2 STUD).....	1.....	S/N J030138 AND BELOW
23A	521941	FRONT COVER (3 STUD).....	1.....	S/N J030139 AND ABOVE
24	511221	6-INCH NPT NIPPLE	1	
25	511838	SHIM, BASE 0.5 MM	AR	
26	511839	SHIM, BASE 1.0 MM	AR	
27	511244	SHIM, KIT, IMPELLER	AR	

PUMP — SUCTION SIDE ASSY.

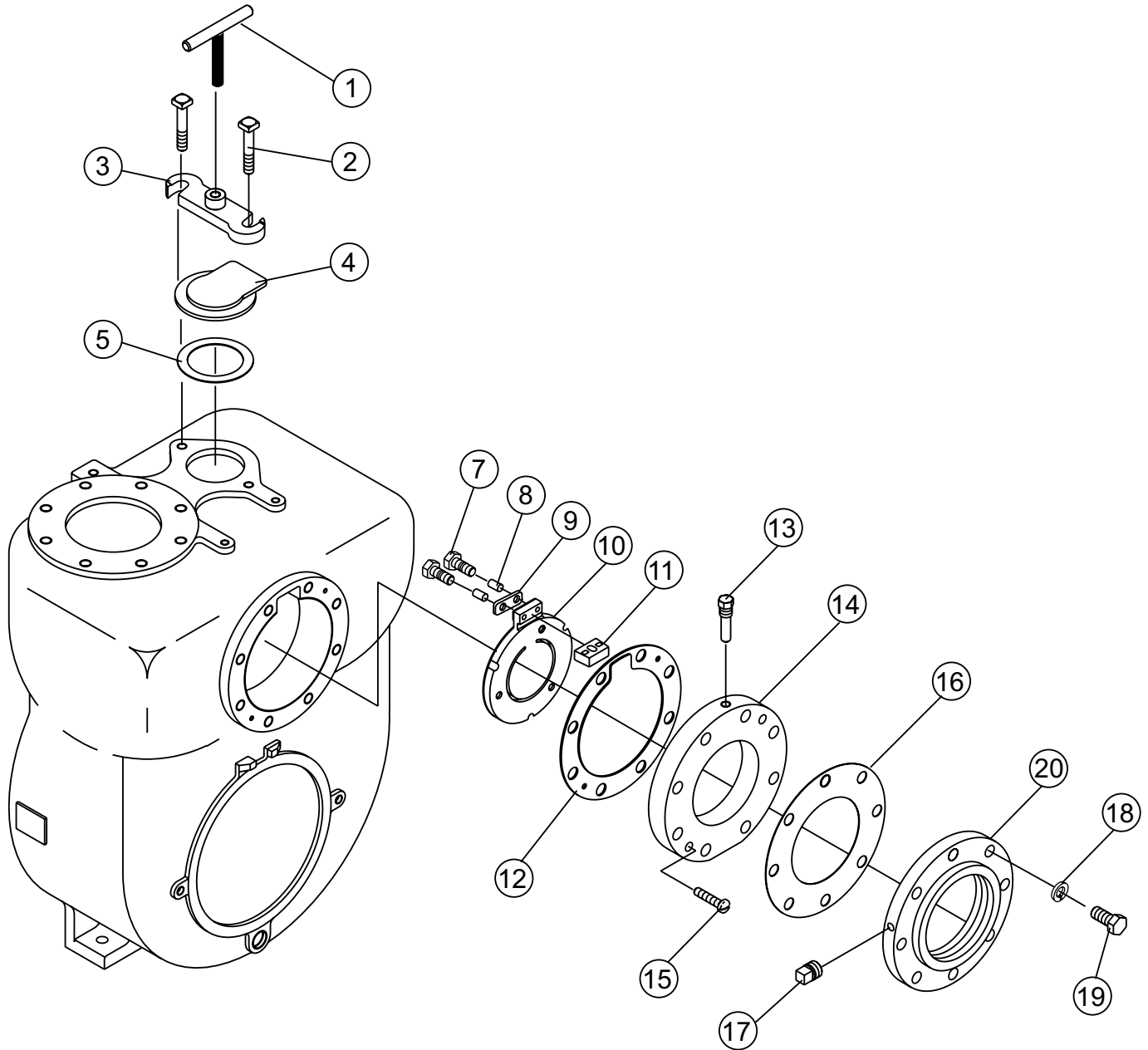

PUMP — SUCTION SIDE ASSY.

<u>NO.</u>	<u>PART NO.</u>	<u>PART NAME</u>	<u>QTY.</u>	<u>REMARKS</u>
1	511836	LOCK BOLT, FILL	1	
2	512061	MACHINE BOLT 5/8" NC 2-1/2" G5	2	
3	511243	RETAINER, FILL	1	
4	511238	COVER, FILL	1	
5	34494	GASKET	1	
7	511303	HHCS, 5/16" X 1-1/4" SS	2	
8	511304	SPACER	2	
9	511305	RETAINER PLATE	1	
10	34489	FLAP VALVE	1	
11	511306	ADAPTER, CHECK VALVE	1	
12	34493	GASKET	1	
13	511307	PIN, CHECK VALVE	1	
14	511278	SEAT, CHECK VALVE	1	
15	511279	SLOT HEAD BOLT 5/16" X 1-1/2"	2	
16	511280	SUCTION GASKET 6"	1	
17	491210	PIPE PLUG NPT 1/4"	1	
18	492628	WASHER, LOCK 3/4"	8	
19	520732	HHCS 3/4" NC X 3-3/4" G5	8	
20	511225	RETAINER OUTLET	2	

INTERMEDIATE PLATE ASSY.

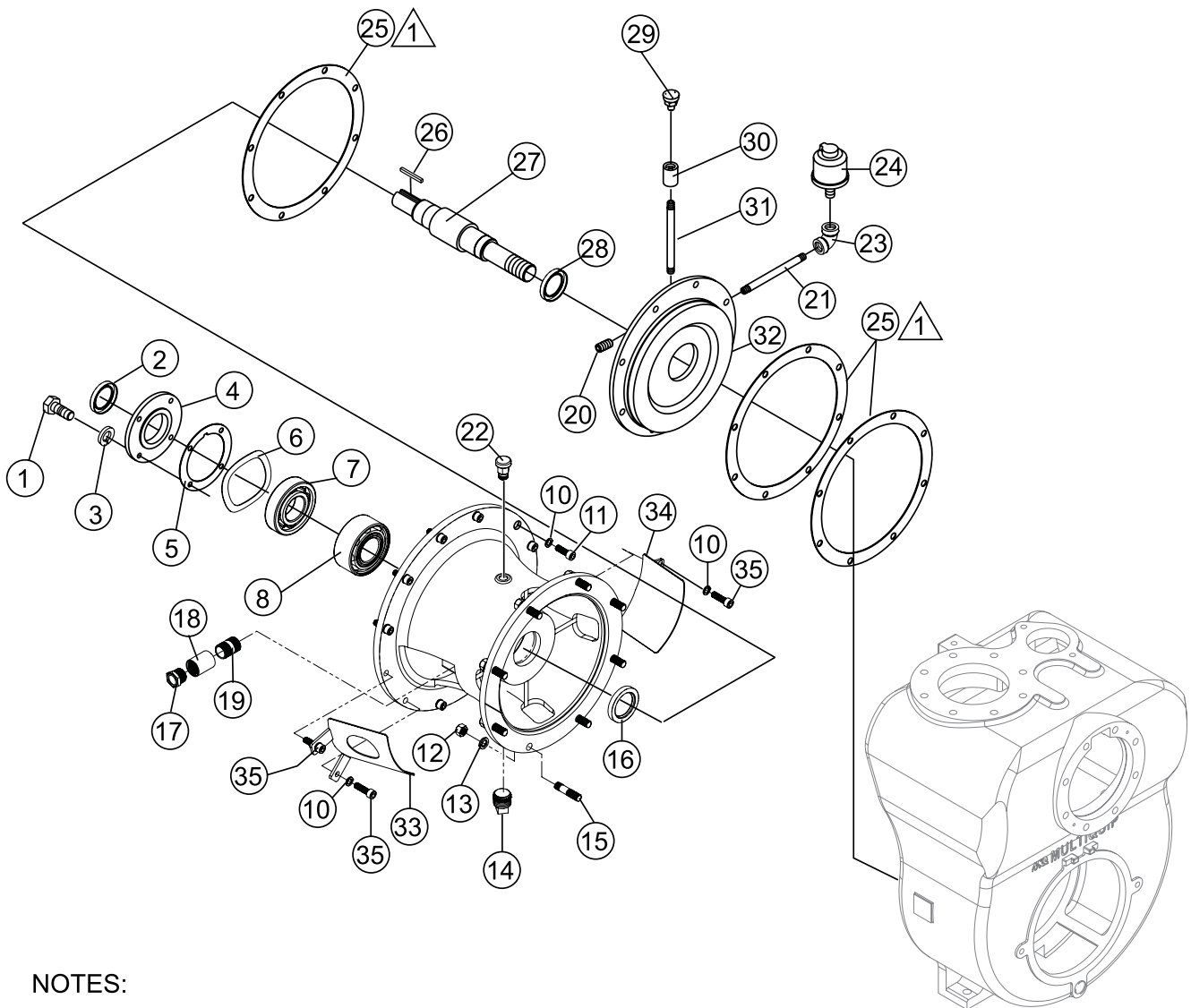

NOTES:



ADJUST FRONT OF IMPELLER TO WEAR PLATE
.010 ~ .020 IN. (0.25 ~ 0.50 MM) USING GASKETS, ITEM 25
AS REQUIRED.

INTERMEDIATE PLATE ASSY.

<u>NO.</u>	<u>PART NO.</u>	<u>PART NAME</u>	<u>QTY.</u>	<u>REMARKS</u>
1	EM963610	CAP SCREW 3/8" NCX1" G5	4.....	REPLACES P/N 492375
2	511259	SEAL, OIL	1	
3	0166 A	WASHER, LOCK, 3/8"	4.....	REPLACES P/N 492624
4	511256	RETAINER PLATE	1	
5	34495	GASKET	1	
6	34490	WAVE WASHER	1	
7	511261	BEARING	1	
8	511262	BEARING	1	
9	511235	INTERMEDIATE HOUSING	1	
10	506622	WASHER, LOCK	8	
11	EM269	ALLEN HEAD M10 X 25	8	
12	508704	HEX NUT 1/2" SS	10	
13	511302	LOCK WASHER 1/2" SS	10	
14	507657	DRAIN PLUG	1	
15	511229	STUD	8	
16	511259	SEAL, OIL	1	
17	490181	BEARING OIL SIGHT GAUGE	1	
18	506214	PIPE COUPLER	1	
19	511249	PIPE NIPPLE	1	
20	511263	PLUG	1	
21	511248	PIPE NIPPLE	1	
22	511233	BREATHER	1	
23	511833	90° ELBOW	1	
24	34501	RESERVOIR OIL, SIGHT GLASS (MEC. SEAL)	1	
25	34492	GASKET	3	
26	511257	KEY	1	
27	511258	SHAFT, IMPELLER	1	
28	511236	SEAL, OIL	1	
29	511230	BREATHER	1	
30	512787	PIPE, COUPLING NPT 1"	1	
31	511248	PIPE NIPPLE	1	
32	511265	ADAPTER COVER	1	
33	511253	GUARD (BEARING SIGHT GLASS)	1	
34	511252	GUARD	1	
35	506612	ALLEN HEAD SCREW M10X35 X 1.5" G8	4	

TRAILER ASSY.

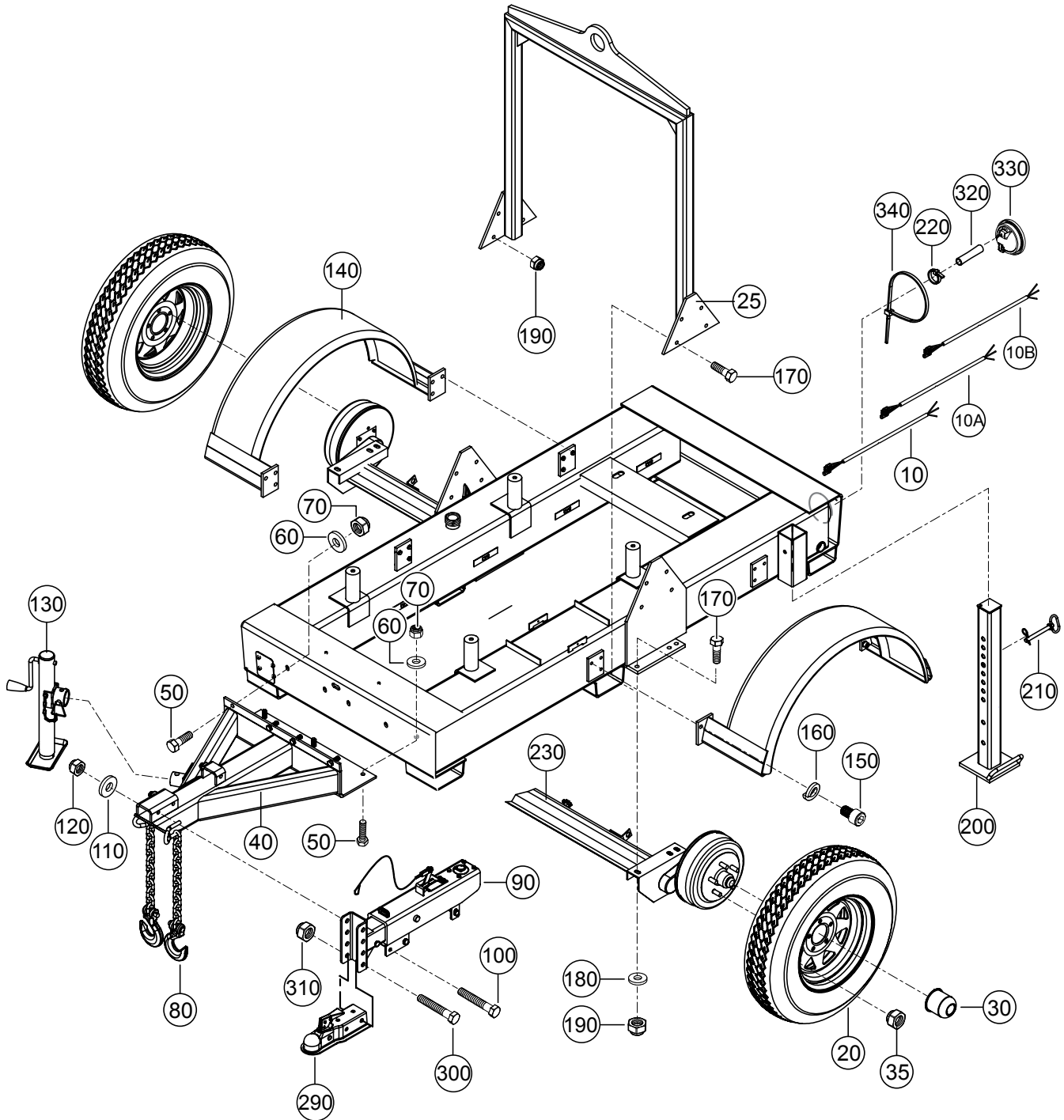

TRAILER ASSY.

<u>NO.</u>	<u>PART NO.</u>	<u>PART NAME</u>	<u>QTY.</u>	<u>REMARKS</u>
10	515640	HARNESS, LIGHTS, 4-PIN	1.....	STANDARD
10A	29367	HARNESS, LIGHTS, 6-PIN	1.....	OPTION
10B	EE55622	HARNESS, LIGHTS, 7-PIN	1.....	OPTION
20	EM516478	TIRE WITH RIM, ST205/75D14C	2	
25	804737	LIFTING BALE	1	
30	516482	CHROMED DUST CAP	2	
35	EM26519	LUG NUT	10	
40	512340	TONGUE, TRAILER	1	
50	EM963692	BOLT, 1/2"UNCX1-1/2", G5.....	9.....	REPLACES P/N 492394
60	EM621	WASHER, FLAT 1/2"	9.....	REPLACES P/N 621
70	492584	NUT, LOCK 1/2" DIA.	9	
80	516581	SAFETY HOOK W/LATCH 1/2"	2	
90	19067	ACTUATOR, BRAKE	1	
100	518257	BOLT, 1/2"UNCX4-1/2", G8	3	
110	6109170	WASHER, FLAT 1/2" DIA.....	3.....	REPLACES P/N 492600
120	492584	NUT, LOCK 1/2" DIA. NC	3	
130	EM25610	JACK STAND, SWIVEL	1	
140	803508	FENDER, TRAILER	2	
150	803692	BOLT, 1/2"NCX3/4" G5	12	
160	6109180	WASHER, LOCK 1/2" DIA.	12.....	REPLACES P/N 492626
170	EM963692	BOLT 1/2"UNCX1-1/2"	14.....	REPLACES P/N 492394
180	EM621	WASHER, FLAT 1/2"	6.....	REPLACES P/N 621
190	492584	NUT, LOCK 1/2" DIA.	14	
200	EM70186	JACK STAND	1	
210	EM744	CLEVIS PIN 1/2"X4"	1	
220	EM491028	WRAP, CABLE TIE.....	6.....	REPLACES P/N 491028
230	34564	AXLE ASSY., TORSION BAR	1	
290	29228	BALL COUPLER, 2" ADJUSTABLE	1	
300	518256	BOLT, 5/8"NCX4-1/2" G8	1	
310	EM969023	NUT, LOCK 5/8"	1.....	REPLACES P/N 492586
320	EM508242	CONNECTOR, BUTT.....	6.....	REPLACES P/N 508242
330	EM26536	TAIL LIGHT, BACK	2	
340	491030	WRAP, CABLE TIE	1	

ENGINE MOUNTING ASSY.

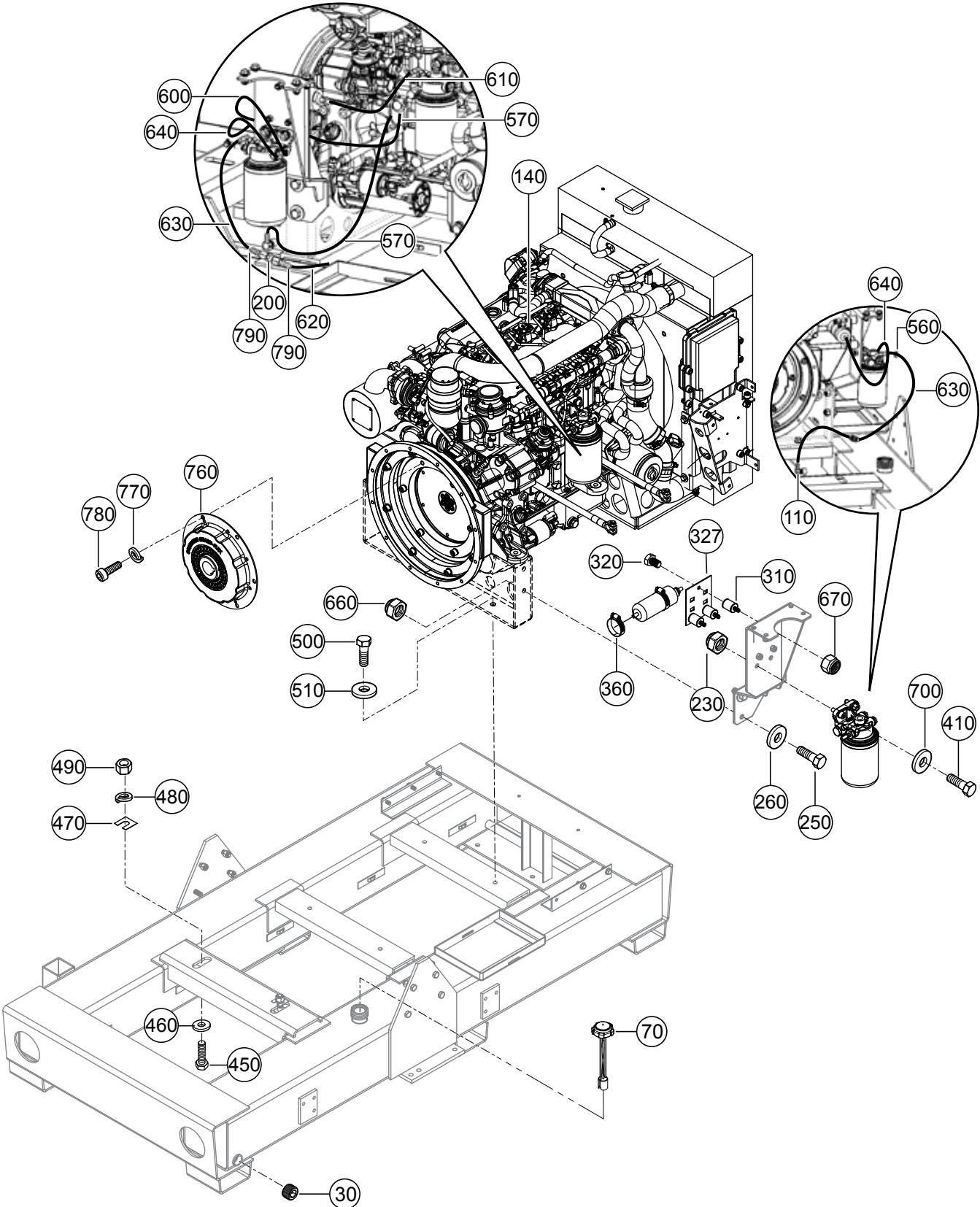

ENGINE MOUNTING ASSY.

<u>NO.</u>	<u>PART NO.</u>	<u>PART NAME</u>	<u>QTY.</u>	<u>REMARKS</u>
30	505988	PLUG, 5/8" ALLEN HEAD	2	
70	34507	FUEL CAP, W/GAUGE	1	
110	514560	ADAPTER	2	
140	521604	ENGINE, HATZ 74.5 HP T4F	1	
200	804627	VALVE, CHECK FUEL	1	
230	EM969013	NUT 3/8"NC, G8	6.....	REPLACES P/N 492583
250	EM963102	BOLT, 1/2" NCX1-1/4" G-5.....	2.....	REPLACES P/N 492393
260	6109170	WASHER, FLAT 1/2" DIA.....	2.....	REPLACES P/N 492600
310	801696	DAMPER FOR FUEL PUMP	3	
320	EM492299	SCREW, HHC 5/16"-18X1/2"	3.....	REPLACES P/N 505401
327	804634	FUEL PUMP BRACKET	1	
360	517328	CLAMP, HS-24	2	
410	EM963610	BOLT 3/8"NCX1-1/4" G5.....	2.....	REPLACES P/N 492376
450	492410	BOLT 5/8" NC X 2-1/2" G5	2	
460	EM507599	WASHER, FLAT 5/8"	2	
470	511838	SHIM BASE .05MM	2	
480	EM923348	WASHER, LOCK 5/8"	2.....	REPLACES P/N 492627
490	EM968013	NUT 5/8" DIA	2.....	REPLACES P/N 492557
500	492395	BOLT 1/2"NCX1-3/4" G5	4	
510	6109170	WASHER, FLAT 1/2".....	8.....	REPLACES P/N 504322
560	37822	CLAMP, 5/16"	12	
570	42459	HOSE, RUBBER FUEL, 5/16", 4.6 FT.....	5.....	1 PC = 1 FT.
600	42459	HOSE, RUBBER FUEL, 5/16", 2.5 FT.....	3.....	1 PC = 1 FT.
610	42459	HOSE, RUBBER FUEL, 5/16", 1.2 FT.....	2	1 PC = 1 FT.
620	42459	HOSE, RUBBER FUEL, 5/16", 1.85 FT.....	2.....	1 PC = 1 FT.
630	42459	HOSE, RUBBER FUEL, 5/16", 0.75 FT.....	1.....	1 PC = 1 FT.
640	42459	HOSE, RUBBER FUEL, 5/16", 1.3 FT.....	2.....	1 PC = 1 FT.
660	492584	NUT, LOCK 1/2" DIA. NC	2	
670	2105164	NUT, NYLON 5/16"-18	3.....	REPLACES P/N 492582
700	EM923023	WASHER, FLAT 5/16"	6.....	REPLACES P/N 492597
760	804798	COUPLER, ENGINE TO PUMP	1	
770	506622	WASHER M10, PRESSURE SS	6	
780	54812	BOLT, 10X25MM	6.....	REPLACES P/N EM162
790	804799	ADAPTER	2	

BATTERY/ENGINE COVER ASSY.

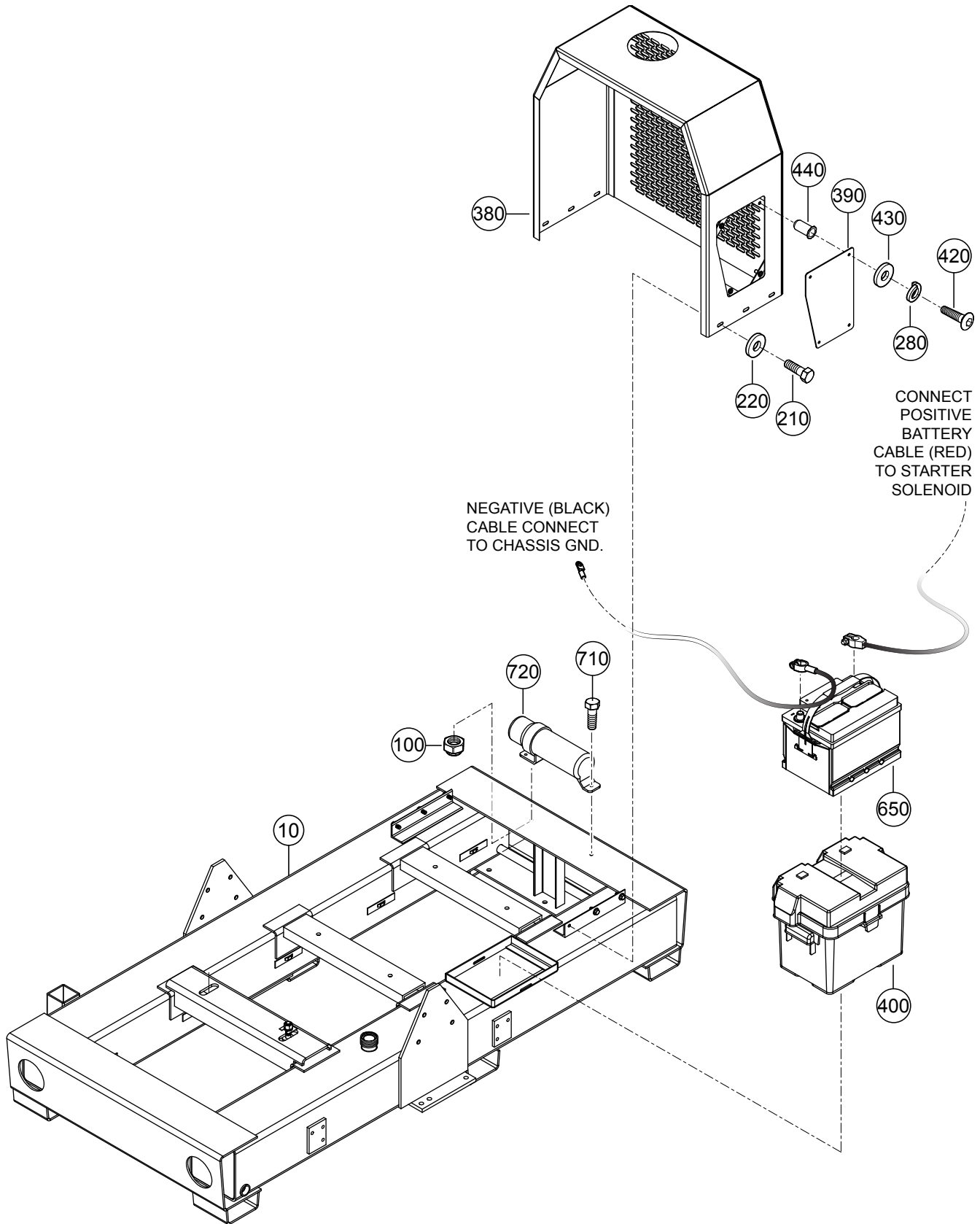

BATTERY/ENGINE COVER ASSY.

<u>NO.</u>	<u>PART NO.</u>	<u>PART NAME</u>	<u>QTY.</u>	<u>REMARKS</u>
10	804652	FRAME	1	
100	2105164	NUT, NYLON 5/16"-18	2.....	REPLACES P/N 492582
210	EM963610	CAP SCREW	6.....	REPLACES P/N 492375
220	EM923023	WASHER, FLAT 5/16"	6.....	REPLACES P/N 492597
280	2101402	WASHER, LOCK 1/4" DIA.	4.....	REPLACES P/N 492622
380	804702	ENGINE COVER	1	
390	804703	ENGINE ACCESS COVER	1	
400	10318	BATTERY BOX, GROUP 24	1	
420	DULT100443	BOLT, M6X20 G2	4	
430	DULT100531	WASHER, FLAT M6	4	
440	DULT100602	RIVET, NUT M6	4	
650	520520	BATTERY, GROUP 24	1	
710	492363	BOLT, 5/16" DIA. NCX3/4" G5	2	
720	23297	MANUAL HOLDER	1	

AIR FILTER ASSY.

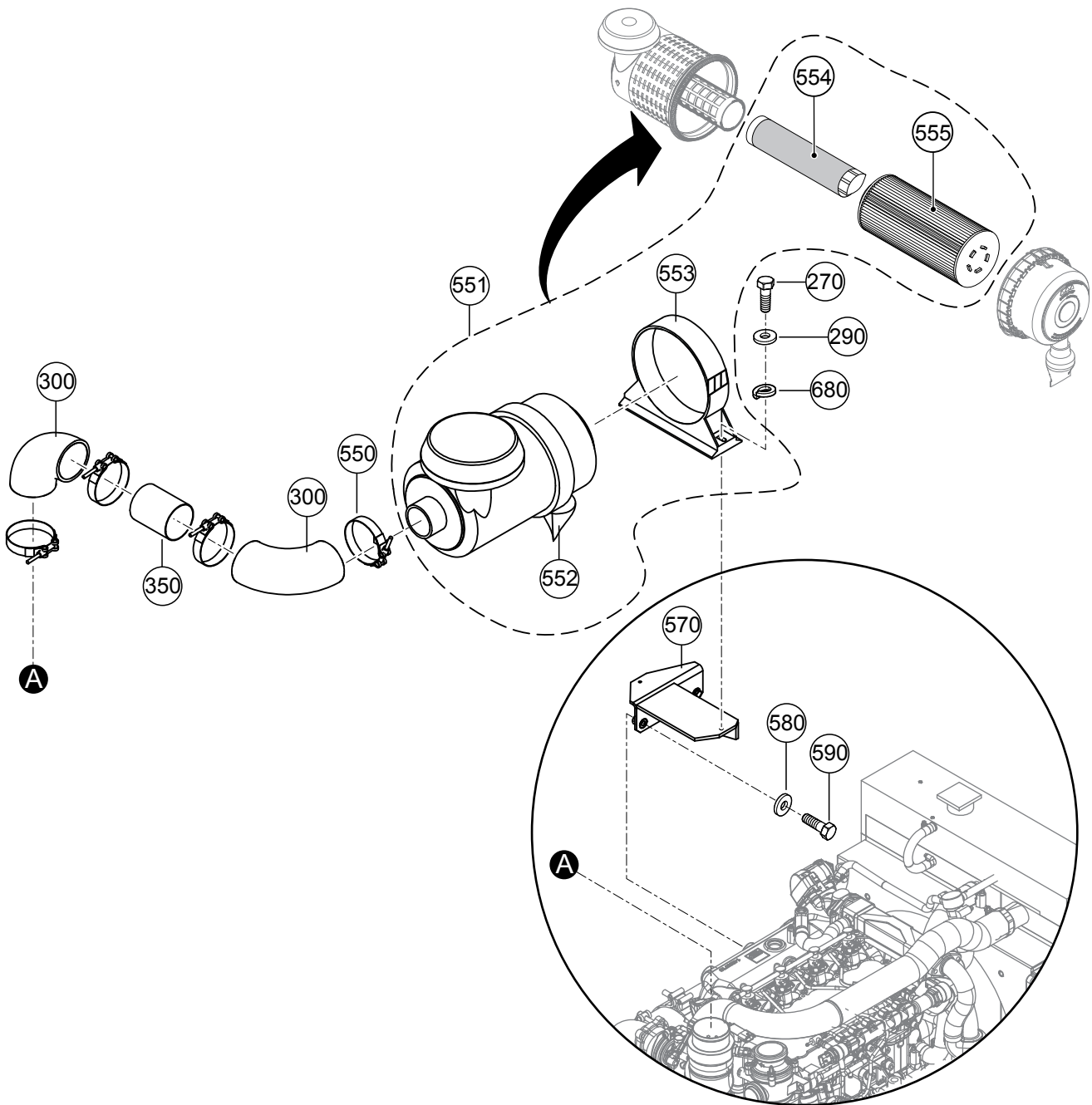

AIR FILTER ASSY.

NO.	PART NO.	PART NAME	QTY.	REMARKS
270	EM492358	BOLT 1/4" NC X 1-1/4".....	2.....	REPLACES P/N 492358
290	492595	WASHER, FLAT 3/16"	2	
300	521639	ELBOW, RUBBER	2	
350	804673	ELBOW, INNER TUBE	1	
550	521638	CLAMP	4	
551	02366900	AIR FILTER ASSY.....	1.....	INCLUDES ITEMS W/#
552#	50660500	RUBBER DUST EVACUATOR	1	
553#	50637400	METAL RELEASE STRAP	1	
554#	50638300	AIR FILTER, SECONDARY	1	
555#	50638200	AIR FILTER, PRIMARY	1	
570	804624	BRACKET AIR FILTER	1	
580	DULT100494	WASHER, FLAT M8	2	
590	DULT100270	BOLT, M8X45	2	
680	2101402	WASHER, LOCK 1/4" DIA.	2.....	REPLACES P/N 492622

CONTROL BOX ASSY.

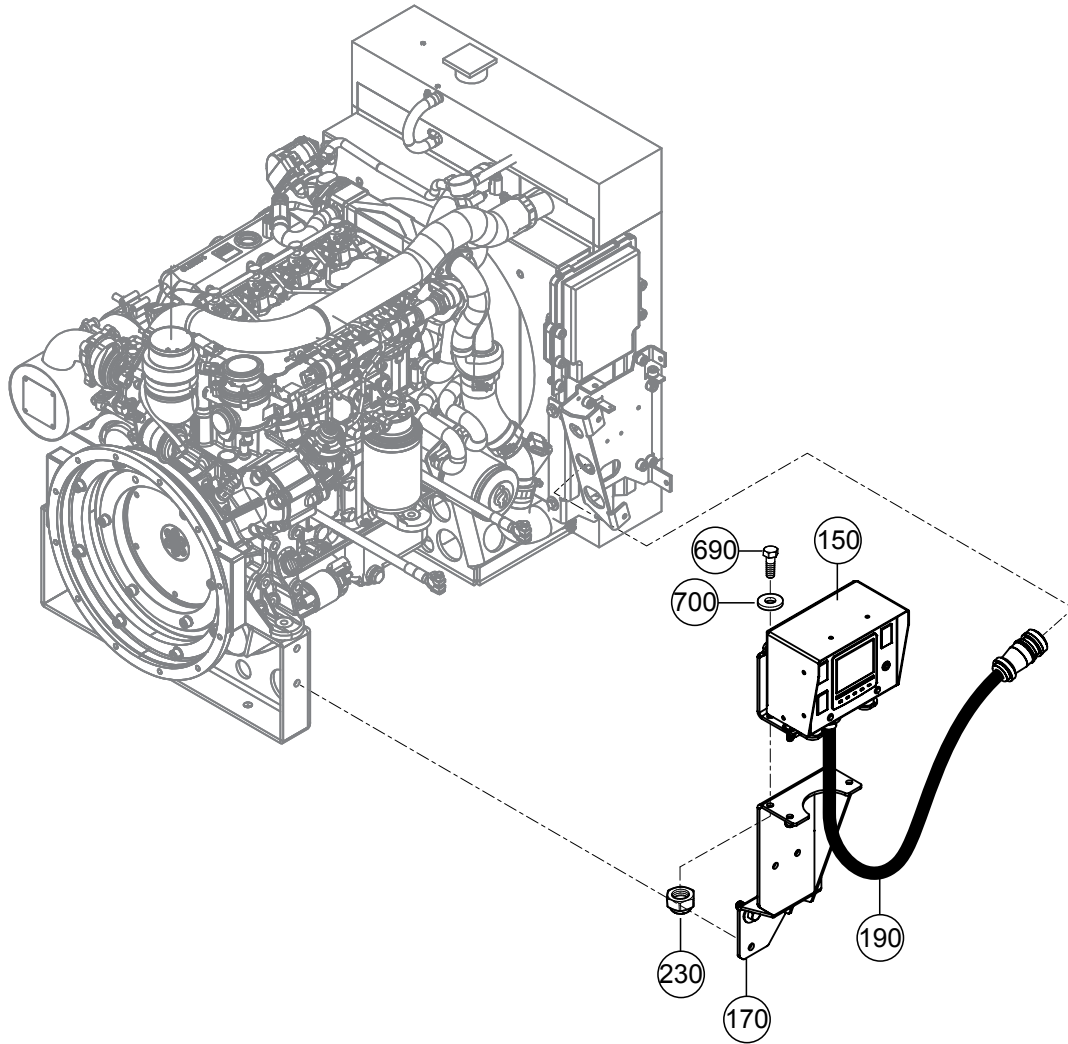

CONTROL BOX ASSY.

<u>NO.</u>	<u>PART NO.</u>	<u>PART NAME</u>	<u>QTY.</u>	<u>REMARKS</u>
150	521605	CONTROL PANEL ASSEMBLY	1	
170	804625	CONTROL PANEL SUPPORT BRACKET	1	
190	521606	CONTROL PANEL POWER CABLE	1	
230	EM969013	NUT 3/8" NC, G8	6.....	REPLACES P/N 492583
690	EM963610	CAP SCREW 3/8" NC X 1" G5	4.....	REPLACES P/N 492375
700	EM923023	WASHER, FLAT 5/16"	6.....	REPLACES P/N 492597

HYDRAULIC BRAKE LINE ASSY.

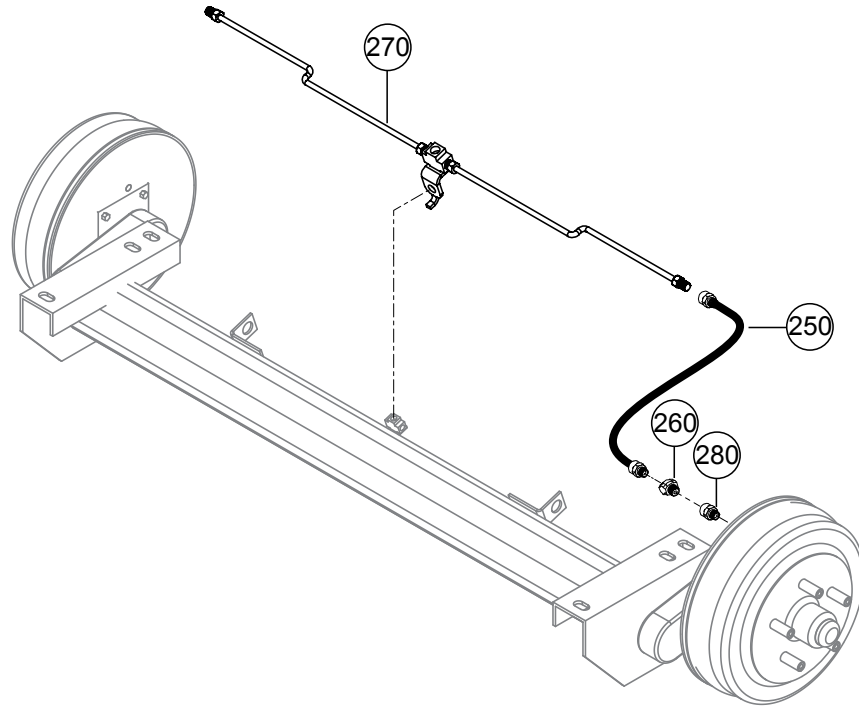

HYDRAULIC BRAKE LINE ASSY.

<u>NO.</u>	<u>PART NO.</u>	<u>PART NAME</u>	<u>QTY.</u>	<u>REMARKS</u>
250	34565	KIT, HYDRAULIC LINE	1	
260	EM512876	ADAPTER	2	
270	34566	KIT, TORSION LINE	1	
280	EM512877	ADAPTER	2	

HATZ 4H50TIC ENGINE SERVICE PARTS

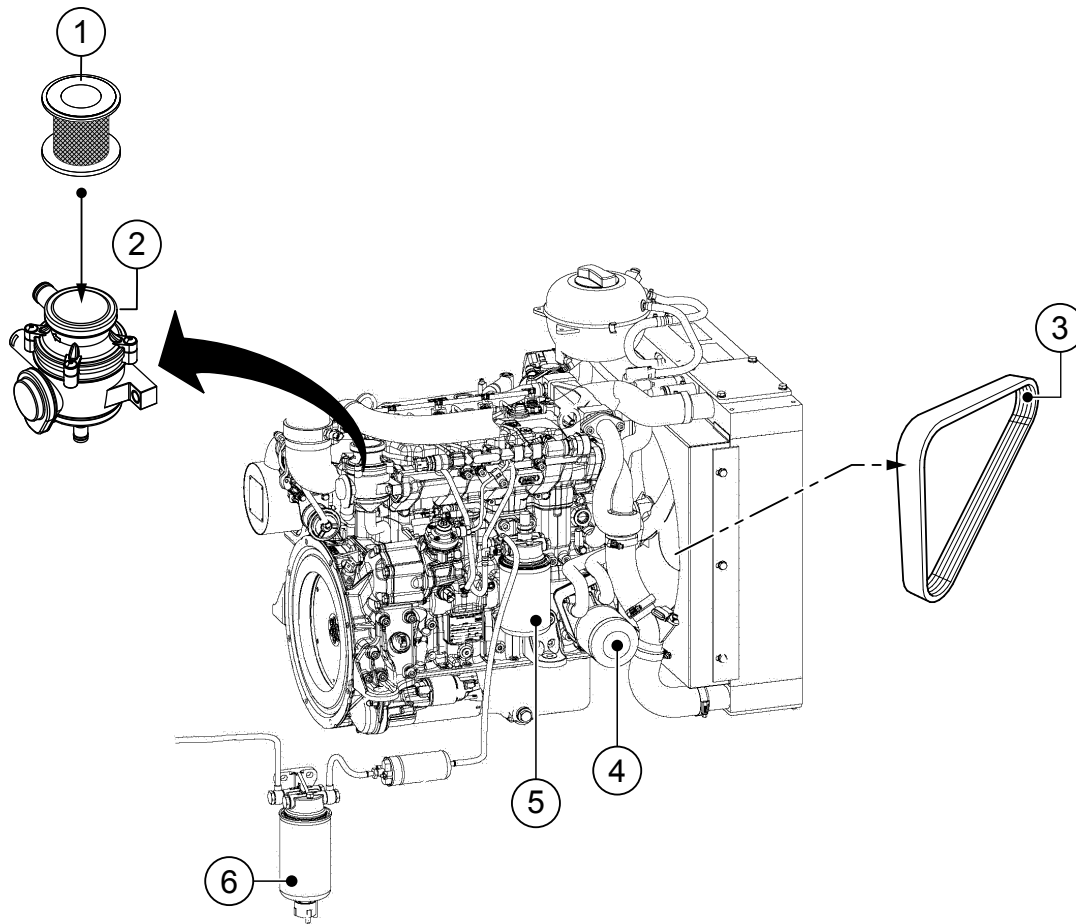

HATZ 4H50TIC ENGINE SERVICE PARTS

<u>NO.</u>	<u>PART NO.</u>	<u>PART NAME</u>	<u>QTY.</u>	<u>REMARKS</u>
1	50640500	FILTER, BREATHER, CRANKCASE	1	
2	60640500	OIL SEPARATOR	1	
3	50629401	POLY V BELT 768	1	
4	50628800	OIL FILTER	1	
5	60638100	FUEL FILTER	1	
6	50638000	PRE FUEL FILTER/WATER SEPARATOR	1	

OPERATION AND PARTS MANUAL

HERE'S HOW TO GET HELP

PLEASE HAVE THE MODEL AND SERIAL
NUMBER ON-HAND WHEN CALLING

UNITED STATES

Multiquip Inc.

(310) 537- 3700
6141 Katella Avenue Suite 200
Cypress, CA 90630
E-MAIL: mq@multiquip.com
WEBSITE: www.multiquip.com

CANADA

Multiquip

(450) 625-2244
4110 Industriel Boul.
Laval, Quebec, Canada H7L 6V3
E-MAIL: infocanada@multiquip.com

UNITED KINGDOM

Multiquip (UK) Limited Head Office

0161 339 2223
Unit 2, Northpoint Industrial Estate,
Globe Lane,
Dukinfield, Cheshire SK16 4UJ
E-MAIL: sales@multiquip.co.uk

© COPYRIGHT 2020, MULTIQUIP INC.

Multiquip Inc, the MQ logo are registered trademarks of Multiquip Inc. and may not be used, reproduced, or altered without written permission. All other trademarks are the property of their respective owners and used with permission.

This manual MUST accompany the equipment at all times. This manual is considered a permanent part of the equipment and should remain with the unit if resold.

The information and specifications included in this publication were in effect at the time of approval for printing. Illustrations, descriptions, references and technical data contained in this manual are for guidance only and may not be considered as binding. Multiquip Inc. reserves the right to discontinue or change specifications, design or the information published in this publication at any time without notice and without incurring any obligations.

Your Local Dealer is:

