

# OWNERS MANUAL

## Small Concrete Saw

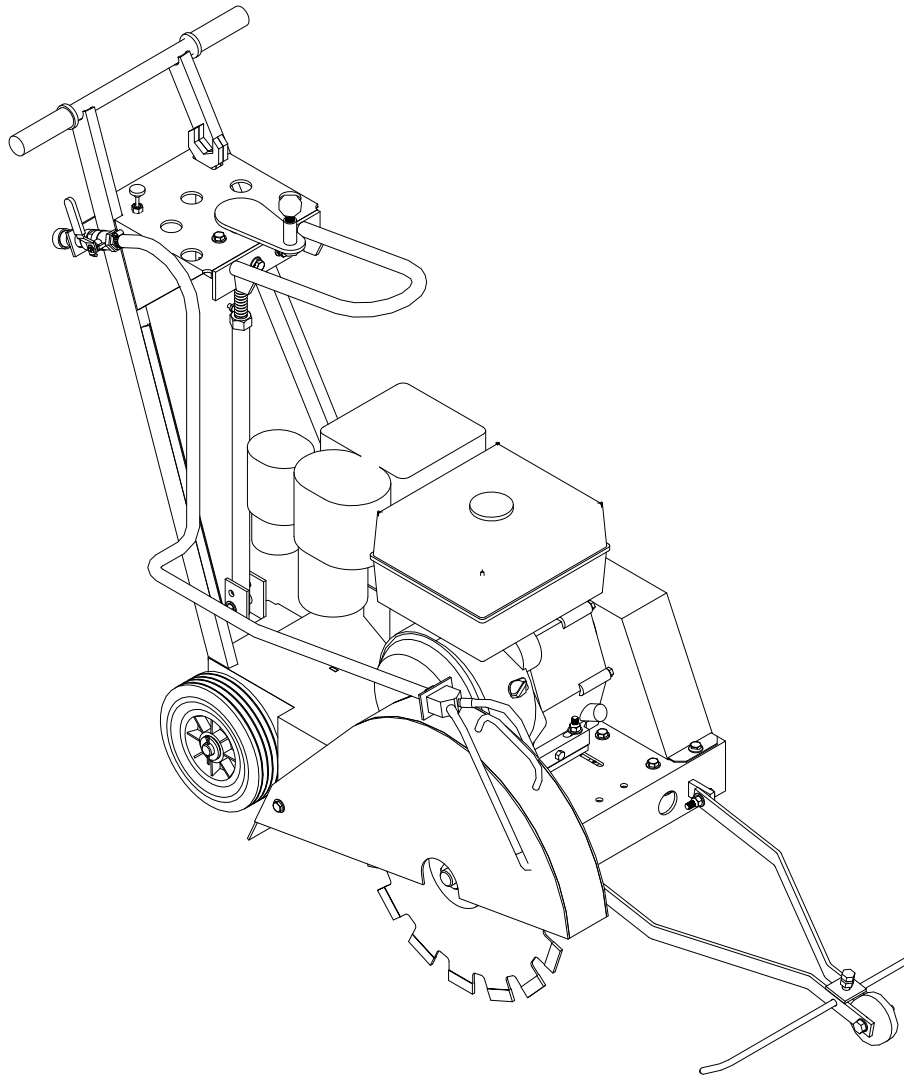

Models:  
**C13PE and C14PE**



**clipper**

FORM: C13PE rev 3-2013

# WARRANTY

Norton warrants all products manufactured by it against defects in workmanship or materials for a period of one (1) year from the date of shipment to the customer.

The responsibility of Norton under this warranty is limited to replacement or repair of defective parts at Norton's Gainesville, Georgia factory, or at a point designated by it, of such part as shall appear to us upon inspection at such point, to have been defective in material or workmanship, with expense for transportation borne by the customer.

In no event shall Norton be liable for consequential or incidental damages arising out of the failure of any product to operate properly.

Integral units such as **gasoline engines, electric motors, batteries, tires, transmissions, etc.**, are excluded from this warranty and are subject to the prime manufacturer's warranty.

This warranty is in lieu of all other warranties, expressed or implied, and all such other warranties are hereby disclaimed.

**Important: Before placing equipment in operation, record the following information.**

**MODEL:** \_\_\_\_\_ **SERIAL NO.** \_\_\_\_\_

**PURCHASE FROM:** \_\_\_\_\_

**ADDRESS:** \_\_\_\_\_

**CITY** \_\_\_\_\_ **STATE** \_\_\_\_\_ **ZIP** \_\_\_\_\_

**TELEPHONE NO.** \_\_\_\_\_

***Before using this equipment, make sure that any person using it reads and understands the instructions in this owner's manual.***

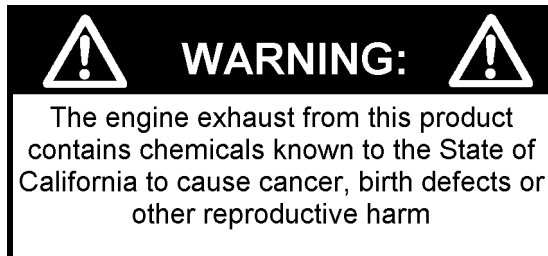

# Table of Contents

<b>CONTENTS</b>	<b>PAGE</b>
<b>I. Preparation</b>	
A. Safety Precautions	4-6
B. Assembly	7
C. C13PE/C14PE Series Concrete Saw Specifications	8
D. Engine Precautions	9
E. Pointer Alignment	9
<b>II. Operation</b>	
A. Blade Installation	9-10
B. Starting The Engine	10-13
C13PE 13HP Honda	10-12
C14PE 14HP Subaru	12-13
C. Water Supply	13
D. Operating The Saw	13-14
E. Cutting Technique	14-16
<b>III. Maintenance</b>	
A. Engine	16-18
B. Wiring Diagram	19-20
C13PE 13HP Honda	19
C14PE 14HP Subaru	20
C. Bearings	21
D. V-Belts	22-25
E. Depth Control	26
F. Inspection and Cleaning	26
<b>IV. Parts List Section</b>	
A. Ordering Information	27
B. Parts Drawing and Service Parts List	28-35
Depth Control And Depth Lock Group	28-29
Blade Guard and water Control Group	30
Engine Group	31
Blade Shaft Group	32
Raise Axle Group	33
Main Frame and Belt Guard Group	34
Front Pointer Group	35



## Read Owners Manual Before Use

Safety Alert Symbol: Information Following This Symbol Is Very Important.

## Use Only Norton Diamond Blades

# I. PREPARATION

## A. Safety Precautions

**Important! The following safety precautions must always be observed.**

### Hazard Symbols



Fuel (gasoline) is extremely flammable and its vapors can explode if ignited. Store gasoline only in approved containers, in well-ventilated, unoccupied approved areas, and away from sparks or flames. Do not fill the fuel tank while the engine is hot or running. Do not start the engine near spilled fuel. Never use the fuel as a cleaning agent



Engine components can get extremely hot from operation. To prevent burns, do not touch the engine or related parts while the engine is running or immediately after it is turned off. Never operate the engine with any heat shields or guards removed.



Keep all guards in place when operating any piece of equipment



Keep hands, feet, hair, and clothing away from all rotating parts

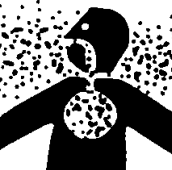

Lethal Exhaust Gas: use only in well ventilated areas. Engine exhaust gases contain poisonous carbon monoxide, which is odorless, colorless, and can cause death if inhaled. Avoid inhaling exhaust fumes, and never run the engine in a closed building or confined area.



Never tamper with the governor components of settings to increase the maximum speed. Severe personal injury and damage to the engine or equipment can result if operated at speed above maximum. Always obey the maximum speed rating of blade.



**DO NOT LIFT THE SAW BY THE HANDLE BARS**

# **WARNING**

## **Dust and Silica Warning**

Grinding/cutting/drilling of masonry, concrete, metal and other materials can generate dust, mists and fumes containing chemicals known to cause serious or fatal injury or illness, such as respiratory disease, cancer, birth defects or other reproductive harm. If you are unfamiliar with the risks associated with the particular process and/or material being cut or the composition of the tool being used, review the material safety data sheet and/or consult your employer, the material manufacturer/supplier, governmental agencies such as OSHA and NIOSH and other sources on hazardous materials and make certain to comply with all product warnings and instructions for the safe and effective use of the material being cut. California and some other authorities, for instance, have published lists of substances known to cause cancer, reproductive toxicity, or other harmful effects.

Control dust, mist and fumes at the source where possible. In this regard use good work practices and follow the recommendations of the manufacturer/supplier, OSHA/NIOSH, and occupational and trade associations. Water should be used for dust suppression when wet cutting is feasible. When the hazards from inhalation of dust, mists and fumes cannot be eliminated through engineering controls such as vacuum and/or water mist, the operator and any bystanders should always wear a respirator approved by NIOSH/MSHA for the material being cut.

### **Use Approved:**



**Eye Protection**



**Hearing Protection**



**Respiratory Protection**

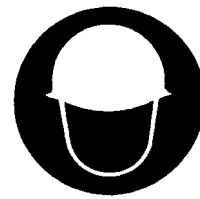

**Head Protection**

1. Before mounting any blade on the saw, the blade should be inspected for any damage which might have occurred during shipment, handling or previous use.
2. The blade collars and arbors should be cleaned and examined for damage before mounting the blade.
3. The blade must be properly fitted over the arbor with the drive pin on the outside collar projecting through the drive pin hole on the blade and inside collar.
4. The blade shaft nut, which is a left-hand thread nut, must be tightened securely against the outside blade shaft collar.
5. The blade must be operated within the specified maximum operating speed listed on the blade.
6. Turn water control valve to full to provide adequate coolant (4 to 6 gallons per minute) for diamond blades and wet cutting abrasive blades. Insufficient coolant could result in severe blade breakage or diamond segment separation.
7. The blade guard must be in place with the nose guard down and locked when the saw is running.
8. The operator should wear safety glasses and any other appropriate safety equipment.
9. When starting the saw, the operator should stand away and to the side of the blade.
10. If for any reason the saw should stall in the cut, raise the blade out of the cut. Check the outside blade shaft collar and nut for tightness. Inspect the blade for damage before restarting the saw. Use caution when resuming a cut. Be certain that the blade is in alignment with the previous cut.
11. During cutting operations do not exert excess side pressure on the handles as a method of steering. Do not force the blade into the cut by lowering the blade too fast or by pushing the saw too fast.



**You Are Responsible For Your Safety!!!**

# I. PREPARATION

## B. Assembly

The C13PE compact concrete saw is shipped completely assembled and ready for use except for diamond blade, gasoline, and oil. Inspect the saw for shipping damage. If any damage is found, contact the shipper immediately and file a freight claim. Norton Clipper is not responsible for any freight-related damages.

Remove the saw from the pallet. Inspect the machine for concealed shipping damaged. Read and understand ALL instruction included in this manual. Failure to understand and follow the instruction covered in this manual can result in injury or damage to the machine. Level the cutting frame and check the engine oil level and add if required (See Engine Manual) and add fuel (See Engine Manual).

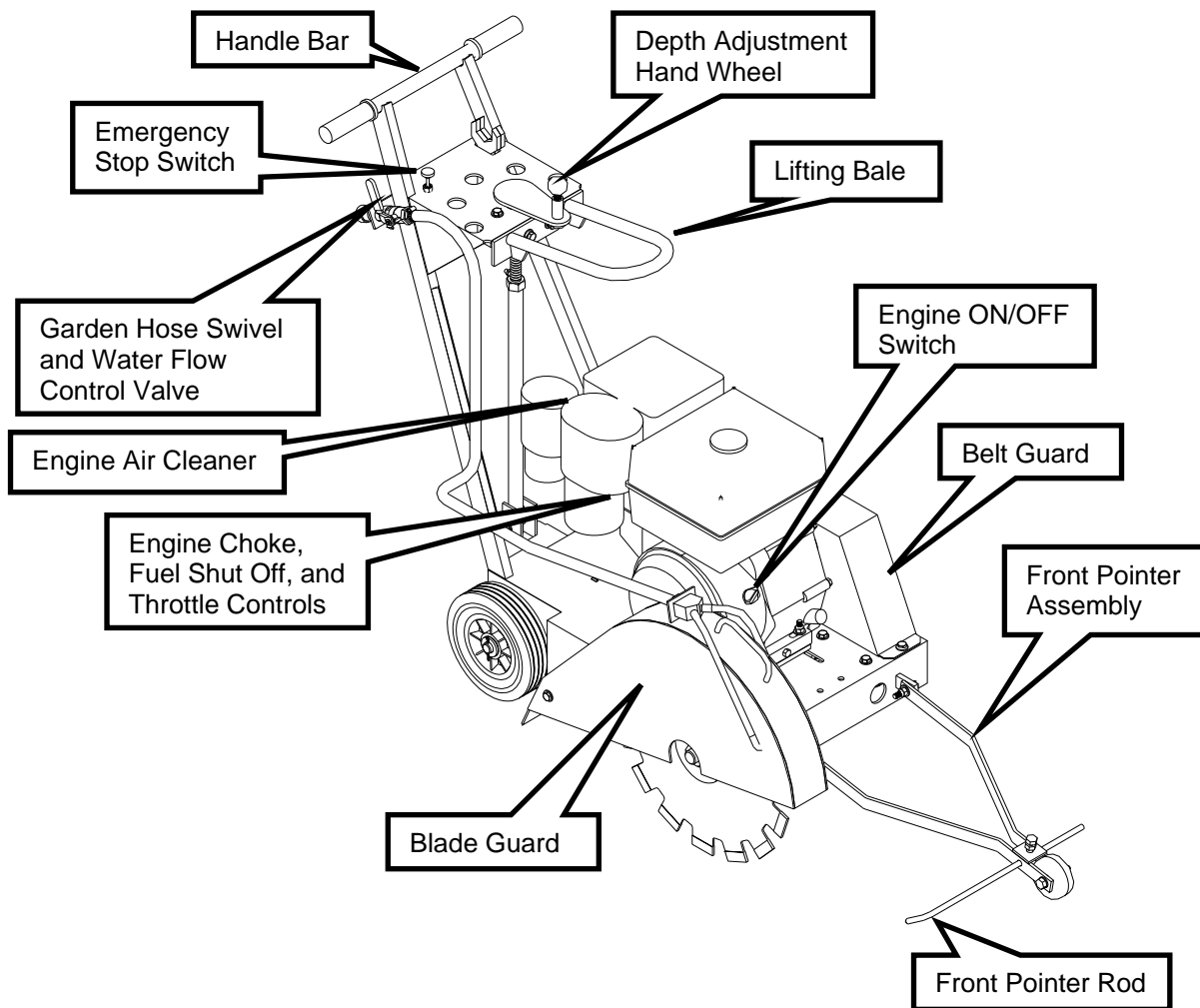

## C. C13PE Series Concrete Saw Specifications

	C13PE	C14PE
<b>Dimensions/Weight</b>		
Length (Working)	63" (1,600mm)	63" (1,600mm)
Length (Transport)	42-3/4" (1,086mm)	42-3/4" (1,086mm)
Width	21-27/64" (544mm)	21-27/64" (544mm)
Height	38-13/16" (986mm)	38-13/16" (986mm)
Weight	220 lbs (100 kg)	220 lbs (100 kg)
<b>Engine</b>		
Engine Mfg.	Honda	Subaru
Model	GX390	EX40
Spec No.	GX390UT2QXC9	EX400D50140
Engine Type	Single Cylinder 4 Cycle	Single Cylinder 4 Cycle
Horse Power - Gross	13 hp* (9.5kW) @ 3,600 rpm	14 hp* (9.5kW) @ 3,600 rpm
Max Torque – Gross	19.5 ft-lbs (26.5 Nm, 2.7 kg-m) @ 2,500 rpm	19.91 ft-lbs (27 Nm, 2.75 kg-m) @ 2,400 rpm
Cooling System	Air	Air
Oil Capacity	1.16 US qt (1.1 liter)	1 US qt (1.2 liter)
Fuel Capacity	1.79 US gal (6.5 liter)	1.85 US gal (7.0 liter)
Fuel Type	Unleaded Gasoline (86 pump octane)	Unleaded Gasoline (86 pump octane)
Low Oil Sensor	Yes	Yes
Air Filtration	Three Stage Cyclone	Three Stage Cyclone
<b>Characteristics</b>		
Max Blade	Ø18" (450 mm)	Ø18" (450 mm)
Depth of Cut	18" (406 mm)	6.75" (172 mm)
	16" (406 mm)	5.75" (146 mm)
	14" (356 mm)	4.75" (121 mm)
	12" (305 mm)	3.75" (95 mm)
Arbor Bore	1" (25.4 mm)	1" (25.4 mm)
Blade Shaft Locking Device	Machined Into Flats Of Tight Collar	Machined Into Flats Of Tight Collar
Blade Shaft Speed	2,700 rpm	2,700 rpm
Depth Control	Hand Wheel With Screw Feed	Hand Wheel With Screw Feed
Depth Lock	Standard	Standard
Depth Gauge	Customer Installed Accessory	Customer Installed Accessory
Number Of Belts	Three (3) 3VX300 Belts	Three (3) 3VX300 Belts
Blade Guard Type	Hinged, All Steel Construction	Hinged, All Steel Construction
Side of Cut	Right	Right
Lifting Bale	Yes	Yes
Water Hose Connector	Standard Garden Hose With Flow Control Valve	Standard Garden Hose With Flow Control Valve
Recessed Rear Wheels	Standard	Standard

\* = Horse power and Torque ratings are Gross Horse power and are supplied by the engine manufacturer. Actual output of the engine will vary due to many factors including operational speed of engine, environmental conditions, maintenance, fuel, and other variables. Saint-Gobain Abrasives, Inc. makes NO claim to actual or gross horse power and torque ratings.



## D. Engine Precautions

***Prior to attempting to operate the engine, read the information contained in the engine owner's manual. An engine owner's manual is supplied with every gasoline powered concrete saw.***

1. **Check Oil:** Add oil if low. Refer to the engine owner's manual for the recommended SAE viscosity grades. Capacity of oil is 1.16 US quarts (1.1 liters)
2. **Check Fuel:** Fill if low. Use only unleaded gasoline with a pump sticker octane rating of 86 or higher is recommended. **Never use an oil and gasoline mixture!**
3. **Air Cleaner:** Never run the engine without the air cleaner! Rapid engine wear will result from contaminants being drawn through the carburetor and into the engine.
4. **Engine Starting:** Refer to the engine owner's manual additional proper engine starting procedure.

## E. Pointer Alignment

1. Use a straight edge, and carefully mark a line 12 feet long on a smooth level surface.
2. Place the saw blade on the marked line, move the saw to the center of the marked line and then lower the blade until it is about 1/16" above the marked line
3. Measure from each end of the saw frame to insure that the frame is parallel to the marked line. Adjust the saw as needed.
4. With the blade centered on the marked line and the saw frame parallel to the marked line, lower the front pointer.
5. Adjust the pointer by bending it until is aligned with the marked line.

## II. OPERATION

### A. Blade Installation

1. Disconnect the spark plug.
2. Remove the blade shaft nut, (Turn clockwise), and remove the outside collar.

- Clean off any foreign particles on the clamping surfaces of both collars and on the mounting surface of the blade.
- Place the blade on the blade shaft, lining up the drive pin hole in the blade with the drive pinhole in the inside collar.



**For Best Performance Use Only Norton Diamond Blades Specified For the Material Being Cut.**

- Slide the outside blade shaft collar onto the blade shaft. The drive pin on the outside collar must project through the drive pin hole in the blade and into the inside collar.
- Tighten the blade shaft nut (counter-clockwise) securely against the outside collar.
- Reconnect the spark plug.

## **B. Starting the Engine C13PE 13HP Honda**

- Refer to the engine owner's manual for detail starting procedures.
- Always cut with engine rpm in the full throttle setting.



**Before starting, insure that the blade is properly installed, all guards are in place and in safe operating condition, and that the Blade is not in contact with any surface or object. Also verify that the area where the work is to be preformed is clean, safe, and has proper ventilation and lighting. Always located and properly mark all water, gas, and electrical services before beginning any work.**

<p>Turn the Fuel Control To the ON Position</p>	<p>Move the choke lever to the CLOSED position. <b>NOTE:</b> The Choke may not be needed if the engine is warm or the air temperature is high.</p>
---	--

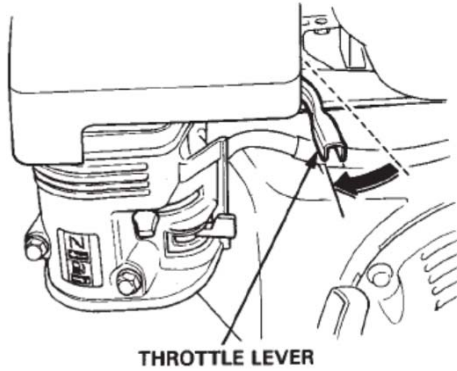

Move the Engine Throttle Slightly to the Left

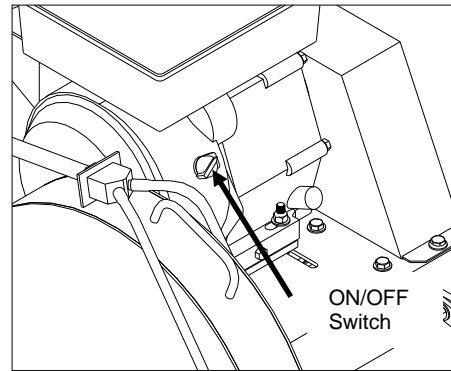

Place the engine ON/OFF switch to the ON position and NOTE: The Engine ON/OFF Switch is located on the front of the Engine.

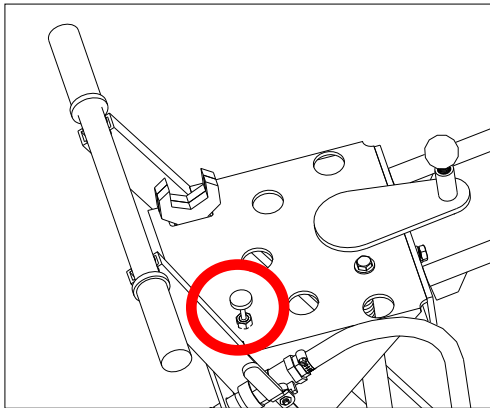

Pull The Emergency Stop Switch to the UP Position. NOTE: The Emergency Stop Switch is located on the machine's Console.

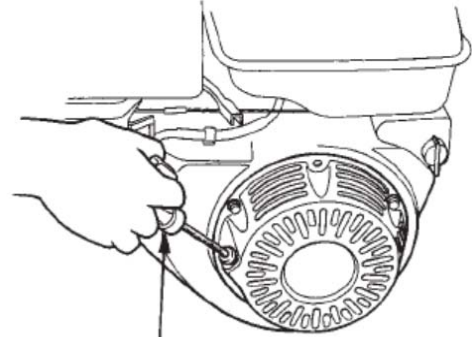

STARTER GRIP

Pull the starter grip lightly until you feel resistance, then pull briskly. **CAUTION:** Do not allow the starter grip to snap back against the engine. Return it gently to prevent damage to the starter.

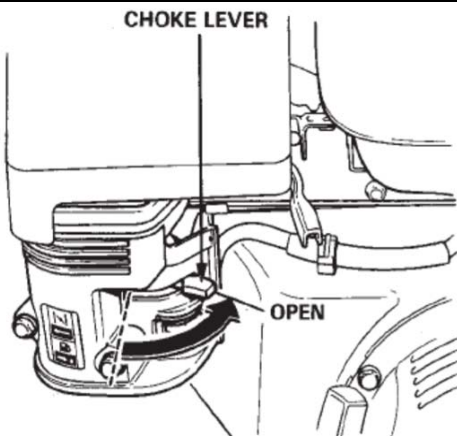

As the engine warms up, gradually move the choke lever to the OPEN position (fully to the right)

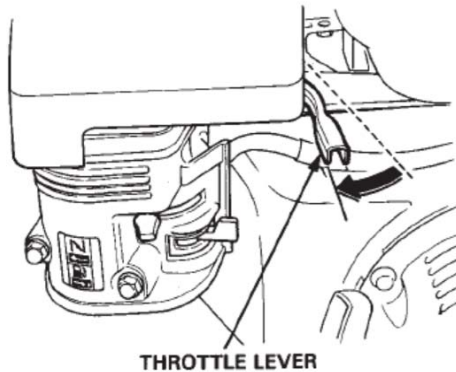

Position the throttle control lever for the maximum engine speed (fully to the Left).

To stop the engine, move the Throttle Control Lever fully to the Forward Position (fully to the right), press the Emergency Stop Switch (Down Position), and then turn the engine switch to the OFF position. Turn the fuel valve to the OFF position.



**Never transport the machine with the Fuel Valve in the ON position. Never Store the machine with the Fuel Valve in the ON position. Never Transport a machine with the blade installed.**

## C14PE 14HP Subaru

1. Refer to the engine owner's manual for detail starting procedures.
2. Always cut with engine rpm in the full throttle setting.



**Before starting, insure that the blade is properly installed, all guards are in place and in safe operating condition, and that the Blade is not in contact with any surface or object. Also verify that the area where the work is to be performed is clean, safe, and has proper ventilation and lighting. Always located and properly mark all water, gas, and electrical services before beginning any work.**

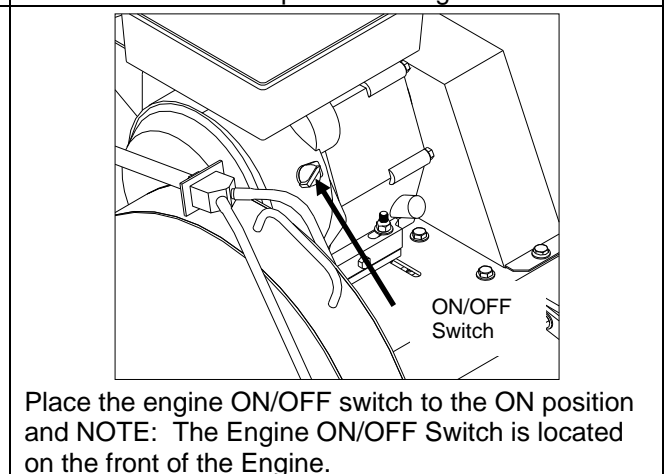
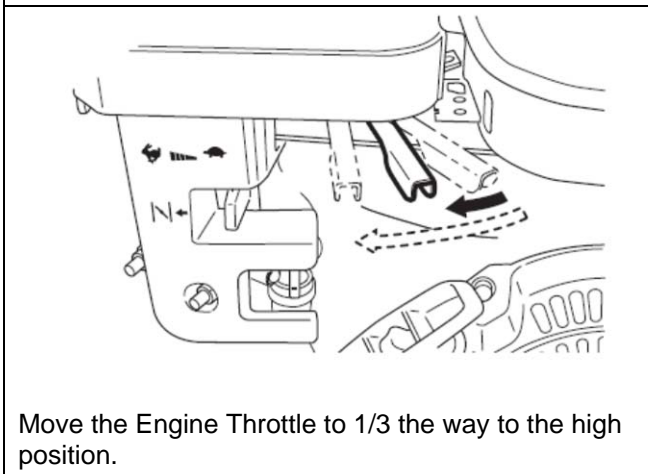
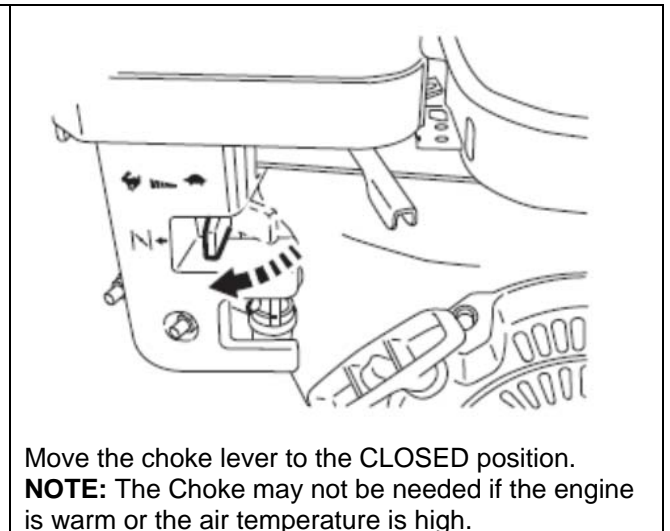
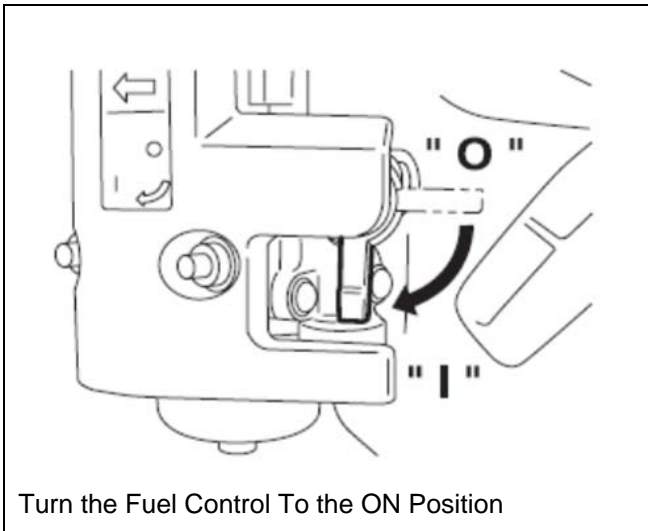

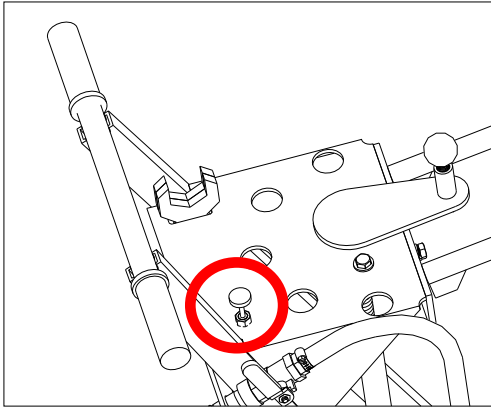

Pull The Emergency Stop Switch to the UP Position.  
NOTE: The Emergency Stop Switch is located on the machine's Console.

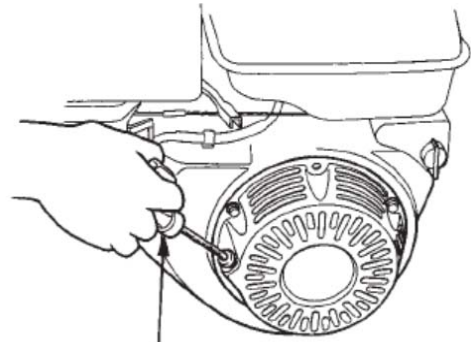

STARTER GRIP

Pull the starter grip lightly until you feel resistance, then pull briskly. **CAUTION:** Do not allow the starter grip to snap back against the engine. Return it gently to prevent damage to the starter.

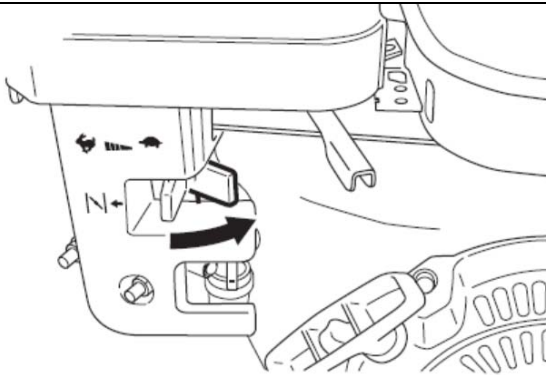

As the engine warms up, gradually move the choke lever to the OPEN position (fully to the right)

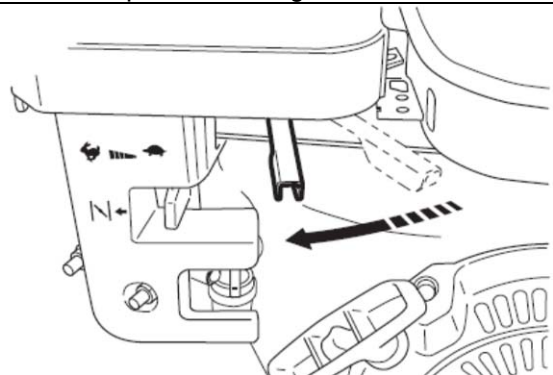

Position the throttle control lever for the maximum engine speed (fully to the Left).

To stop the engine, move the Throttle Control Lever fully to the Forward Position (fully to the right), press the Emergency Stop Switch (Down Position), and then turn the engine switch to the OFF position. Turn the fuel valve to the OFF position.



**Never transport the machine with the Fuel Valve in the ON position. Never Store the machine with the Fuel Valve in the ON position. Never Transport a machine with the blade installed.**

## C. Water Supply

**Pressurized source:** Turn the water control to full "ON" when using wet cutting blades. The required flow rate is 4-6 gallons per minute.

## D. Operating the Saw

1. For blade installation instructions **see section II. Operation sub heading A. Installing the Blade.** For the engine starting instructions, see the

Engine manual and follow the instructions located in section II. **Operation sub heading B. Starting the Engine.**

2. Check the Engine Oil level. See Engine Manual for details.
3. Raise the saw to the full upright position. Do not let the blade come in contact with the ground.
4. Maneuver the saw to the desired starting point.
5. If wet cutting, connect the water supply to the saw.
6. Follow the instructions for starting the engine found in the Engine manual.
7. If wet cutting, turn on the water supply at the source and then open the water valves on the saw. Make sure that there is a minimum of 4-6 gallons per minute of water flow!!
8. Be sure the engine is running at full throttle!!!
9. Slowly lower the blade by rotating the hand wheel clockwise until the desired depth of cut is reached. Use a reasonable rate of feed. Do not force the blade into the cut!!
10. When the end of the cut is reached, slowly raise the blade out of the cut by rotating the Hand Wheel counter-clockwise until the blade is at least one (1) inch above the ground.
11. Only move the saw in reverse with the blade in the raised position.
13. When moving the saw to a new location, be sure the blade is not touching the ground. Always pay close attention to where you are moving and where the blade is at all times.

## **E. Cutting Technique**

Lower the blade into the concrete to the required depth by turning the hand wheel clockwise.

Reduce the forward pressure if the saw begins to stall.

Note: For deeper cuts (4 inches or more), several cuts should be made in incremental steps of 1-1/2 to 2 inches until the desired depth of cut is reached.

Push the saw steadily forward using the front pointer as a guide. Exert enough forward pressure so that the engine begins to labor, but does not slow down. If the saw begins to stall, reduce the forward movement until full rpm is restored to the blade. If the saw stalls, raise the blade out of the cut before restarting. Avoid excessive side pressure or twisting of the blade in the cut.

## **Additional Guide Lines For Sawing:**



- Understand and follow all of the instructions in this owner's manual.
- If wet cutting, turn on the water supply so that there is a minimum of 4-6 gallons per minute of water flow!!
- In critically hard aggregate, more than a single pass may be needed to cut the desired depth.
- If the saw stalls in the cut, immediately stop the forward speed and raise the blade out of the cut. If this is not done the belts can fail or the blade may be damaged.
- Go slowly with a new blade until it opens up, that is, until the diamonds can be seen and felt.

### III. MAINTENANCE

#### A. Engine

Follow the below schedule for engine maintenance. NOTE: Check the Honda Engine manual that came with the engine for any changes to the maintenance schedule. If the charts have any differences, follow the chart in the Honda Engine Manual. Norton does not warranty the engine. If any warranty or service of the engine is required contact your nearest Honda service center, or from the Internet: <http://engines.honda.com/dealer-locator>

Honda engine (refer to owner's manual for complete maintenance.)

#### Honda Engine Maintenance Schedule

#### HONDA GX340 - GX390K1/R1/T1/U1/UT1 Maintenance Information

ITEM	REGULAR SERVICE PERIOD (1)				
	Perform at every indicated month or operating hour interval, whichever comes first.				
	Each use	First month or 20 hrs.	Every 3 months or 50 hrs.	Every 6 months or 100 hrs.	Every year or 300 hrs.
Engine oil	A B	•	•	•	•
Air cleaner	C D	•	• (2)		• (3)
Sediment cup	E			•	
Spark plug	F			•	•
Spark arrester (applicable types)	G			• (5)	
Idle speed	H				• (4)
Valve clearance	I J				• (4)
Combustion chamber	K				• (4)
Fuel tank and filter	L			• (4)	
Fuel tube	N				• (4)

(1) For commercial use, log hours of operation to determine proper maintenance intervals.

(2) Service more frequently when used in dusty areas.

(3) Replace paper element type only.

(4) These items should be serviced by your servicing dealer, unless you have the proper tools and are mechanically proficient. Refer to Honda shop manual for servicing procedures.

(5) In Europe and other countries where the machinery directive 2006/42/EC is enforced, this cleaning should be done by your servicing dealer.

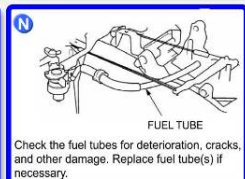
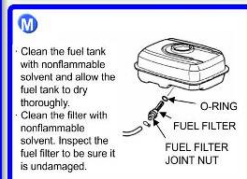
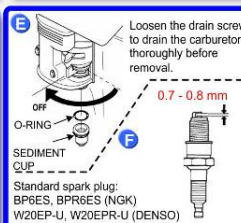
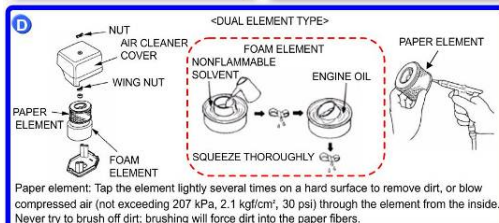
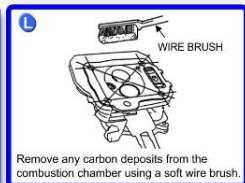
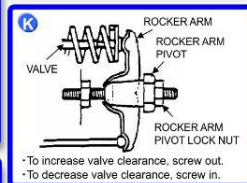
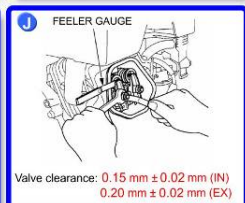
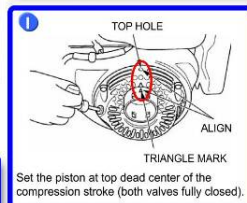
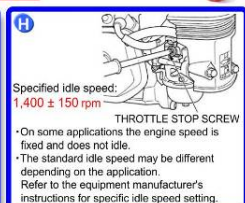
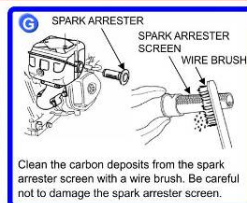
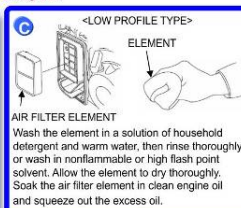
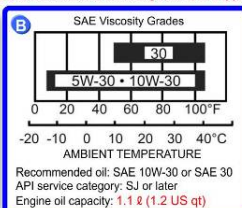
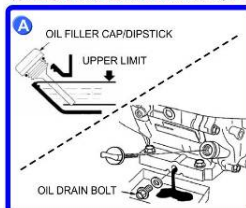

# Subaru Engine Maintenance Schedule

## Periodic Maintenance Schedule table

MS2230

Maintenance Items	Every 8 hours (Daily)	Every 50 hours (Weekly)	Every 200 hours (Monthly)	Every 500 hours	Every 1000 hours
Clean engine and check bolts and nuts	● (Daily)				
Check and refill engine oil	● (Refill daily up to upper level)				
Change engine oil (*Note 1)	● (Initial 20 hours)	● (Every 100 hours)			
Clean spark plug		● (Every 100 hours)			
Clean air cleaner		●			
Clean spark arrester (Optional part)		● (Every 100 hours)			
Replace air cleaner element			●		
Clean fuel cup			●		
Clean and adjust spark plug and electrodes			●		
Replace spark plug				●	
Remove carbon from cylinder head (*Note 2)				●	
Check and adjust valve clearance (*Note 2)				●	
Clean and adjust carburetor (*Note 2)				●	
Replace fuel lines					● (Yearly)
Overhaul engine if necessary (*Note 2)					●

\*Note 1: Initial oil change should be performed after first twenty (20) hours of operation. Thereafter change oil every hundred (100) hours. Before changing oil, check for a suitable way to dispose of old oil. Do not pour it down into sewage drains, onto garden soil or into open streams. Your local zoning or environmental regulations will give you more detailed instructions on proper disposal.

\*Note 2: As to the procedures for these items, please refer to the SERVICE MANUAL or consult your nearest service dealer.

Check the engine oil level before each use when the engine is cool and the engine is level. Add oil if the level is low. The oil level should be within the operating range (see the engine owner's manual for details).

Only use a high-detergent, premium quality motor oil certified to meet or exceed U.S. automobile manufacturer's requirements for Service Classification SG, SF/CC, or CD. Motor oils will show the classification on the container. A SAE viscosity of 10W-30 is recommend by Honda for general, all temperature use. Please consult the below chart or contact your local Honda service center for the proper viscosity for your temperature range.

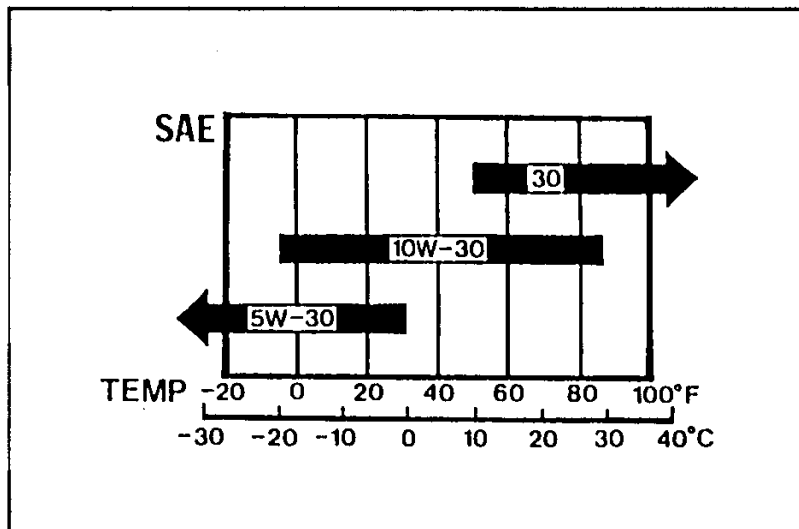



Always refer to the engine manual for more detailed information on checking the oil, changing oil, and oil capacity, air filter changes, and fuel type to use. Use only Honda air filters. Do not clean the air filter with gasoline or other flammable solvents. A fire or explosion could result. To clean, follow the instructions found in the Honda engine manual.

## **Dry Cutting Engine Maintenance**

- When operating the engine in dry cutting or dusty environments the following is required:
- Engine oil changed more often.
- Every 50 hours (or more often if conditions require) clean all of the engine cooling fins.
- Every 25 hours (or more often if conditions require) clean the engine pre-cleaner.
- Every 100 hours (or more often if conditions require) replace the air filter. If the engine is equipped with a reusable air cleaner, clean and re-oil it.
- Check and clean the air filter after each use. Replace as needed.

## B. Wiring Diagram

### C13PE 13HP Honda

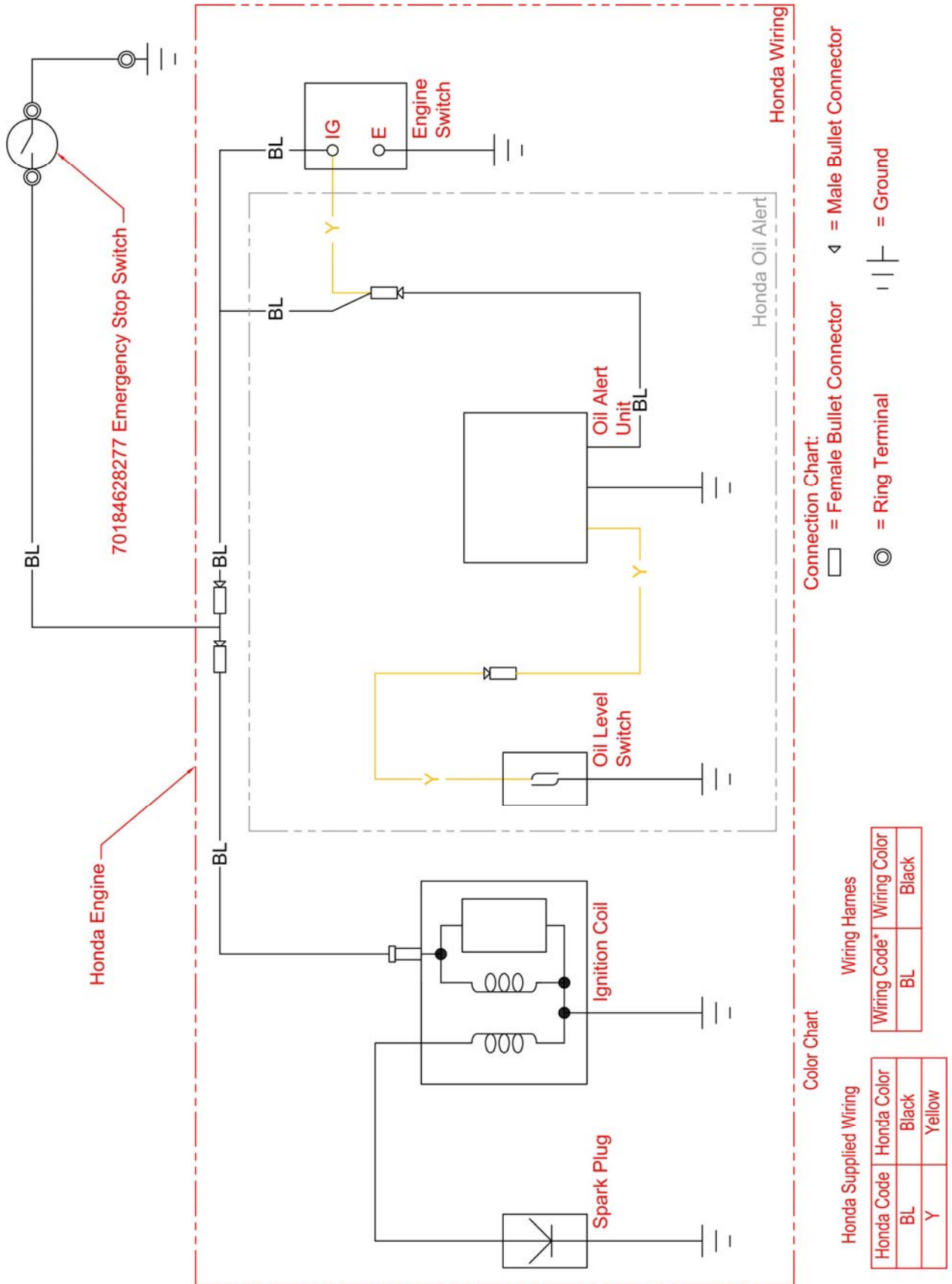

# C14PE 14HP Subaru

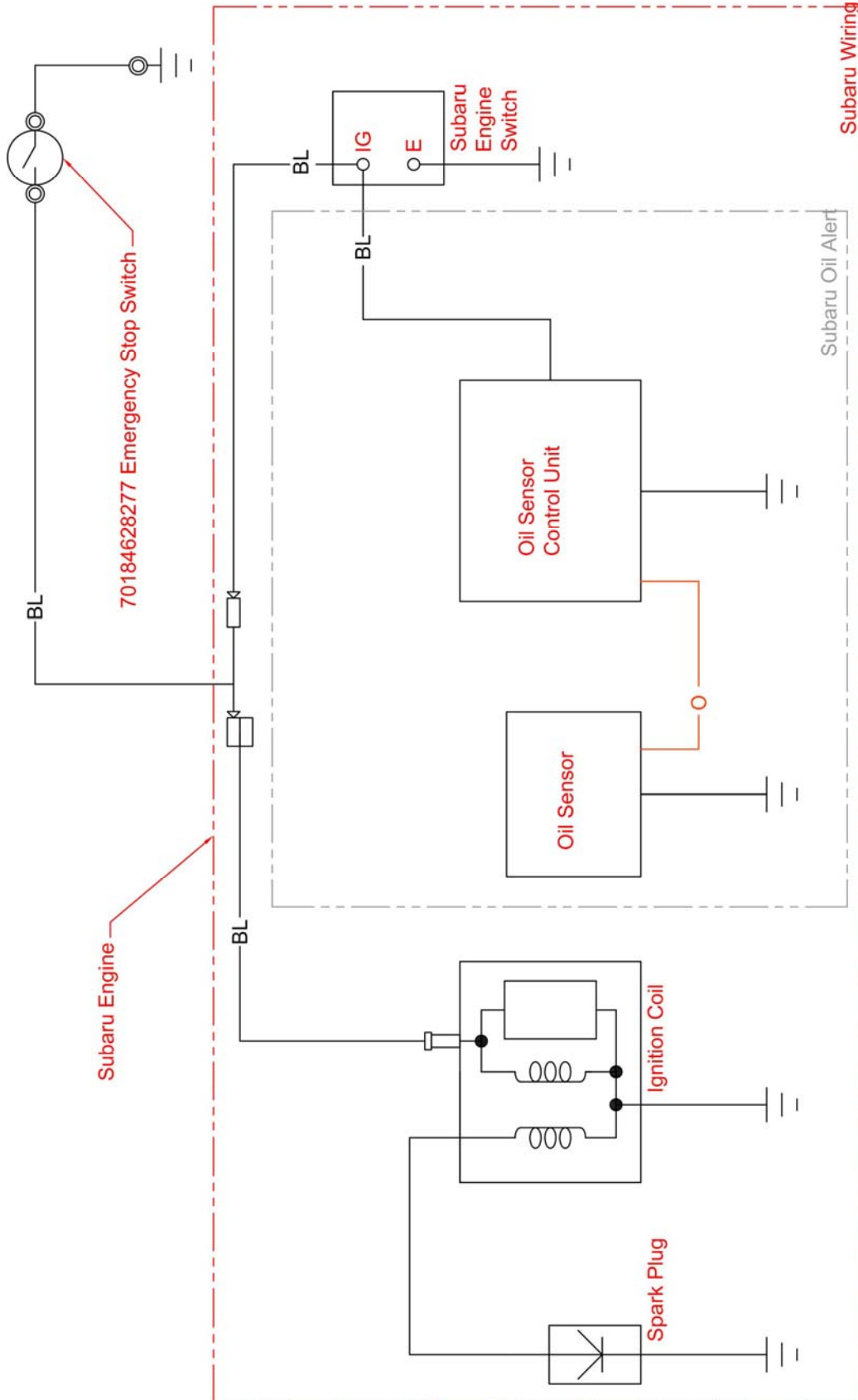

**Subaru Wiring**

**Subaru Oil Alert**

**Subaru Engine Switch**

**Oil Sensor**

**Oil Sensor Control Unit**

**Ignition Coil**

**Spark Plug**

**70184628277 Emergency Stop Switch**

**Subaru Engine**

**Connection Chart:**

- = Female Bullet Connector
- ◁ = Male Bullet Connector
- ⊙ = Ring Terminal
- ⊞ = Ground
- ⊞ = Subaru Double Female Connector

**Color Chart**

**Subaru Supplied Wiring**

Honda Code	Honda Color
BL	Black
O	Orange

**Wiring Harness**

Wiring Code*	Wiring Color
BL	Black

## C. Bearings

Re lubrication type bearings must be re-lubricated weekly to assure long life. The grease used should conform to the NLGI grade two and be free of any chemical impurities such as free acid or free alkali, dust, rust, metal particles or abrasives.

For best results, bearings should be re-lubricated while in operation. **Note: Due caution for personal safety must be observed when servicing rotating equipment.** The grease should be pumped in slowly until a slight bead forms around the seals. This bead, in addition to acting as an indicator of adequate re-lubrication, provides additional protection against the entry of foreign matter. If necessary to re-lubricate while the bearing is idle refer to re-lubrication table for maximum grease capacity for the various size bearings.

Shaft Size	Maximum Grease Capacity of Bearing Chamber in Ounces
1/2" to 3/4"	1/8
7/8" to 1-3/16"	3/8
1-1/4" to 1-1/2"	5/8



**Improper Maintenance Of Bearings Is Not Covered By Any Warranty. Over Lubrication Will Damage A Bearing. Grease Protruding From The Sides Of The Bearing Is A Sign Of Over Lubrication. Not Lubricating Bearings Will Damage The Bearing Unit. Damage Caused By Over or Under Lubricating Bearings Is Not Covered By Any Warranty.**

## D. V-Belts

**Warning: Never make adjustments to belts or pulleys while engine is running!**

The best tension for a belt drive is the lowest tension at which the belts will not slip under full load.

### To adjust the C13PE Belt Tension:

The C13PE uses a simple single point tensioning system for the belt tensioning. The Belt Tensioning Assembly can be found behind the engine and is located near the Operator's Left Side Rear Engine Mounting Bolt. The Belt Tensioning Device is designed to pull or push the engine from the center which helps to reduce the Engine from twisting during the Belt Tensioning process. This new system is designed to be simple to install and to maintain with the tools equipped with the machine.



Insure that the Engine ON/OFF Switch is in the OFF position and that the Spark Plug is disconnected before making any adjustment to the Belt tension.

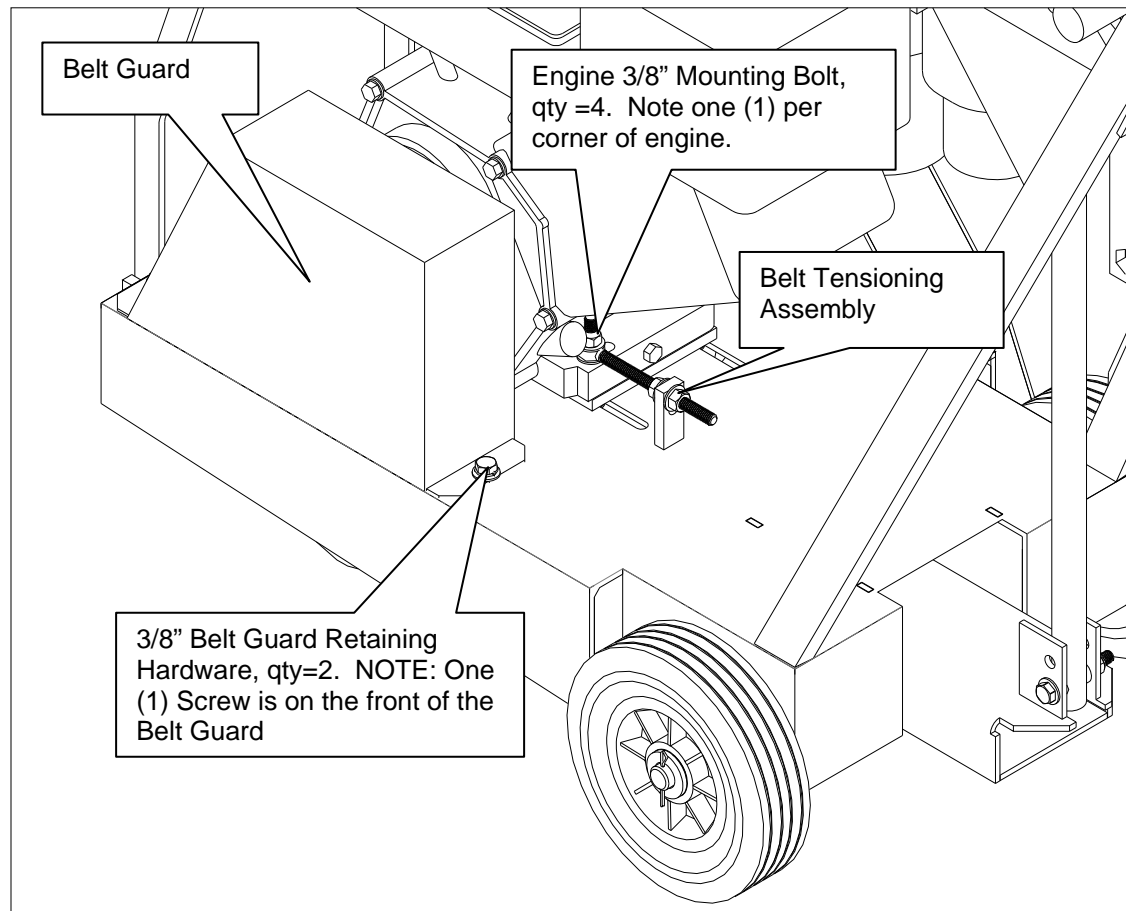

**Figure: C13PE Belt Tensioning System**

1. Review the locations of the C13PE Belt Tensioning system before proceeding. (See **Figure: C13PE Belt Tensioning System** on the previous page).
2. Remove the Belt Guard by loosening and removing the two (2) 3/8" Belt Guard Retaining Hardware sets.
3. Check belt tension by pushing up or down at the center top span of the belt. The belt should move around 3/8" to 1/2" up and down. If adjustment is needed go to step 4. If no adjustment is required, replace belt guard and tighten all of the 3/8" Belt Guard Retaining Hardware.
4. Slightly loosen the four (4) 3/8" Engine Mounting Bolts. NOTE: The four 3/8" Engine Mounting Bolts will need to remain snug during the belt tensioning process. Not keeping the 3/8" Engine Mounting Bolts snug may allow the engine to twist in the mounting slots which may result in the pulleys becoming missed aligned.
5. Loosen the two (2) 3/8" Jam Nuts on the C13PE Belt Tensioning Assembly (See **Figure: C13PE Belt Tensioning Assembly** below).

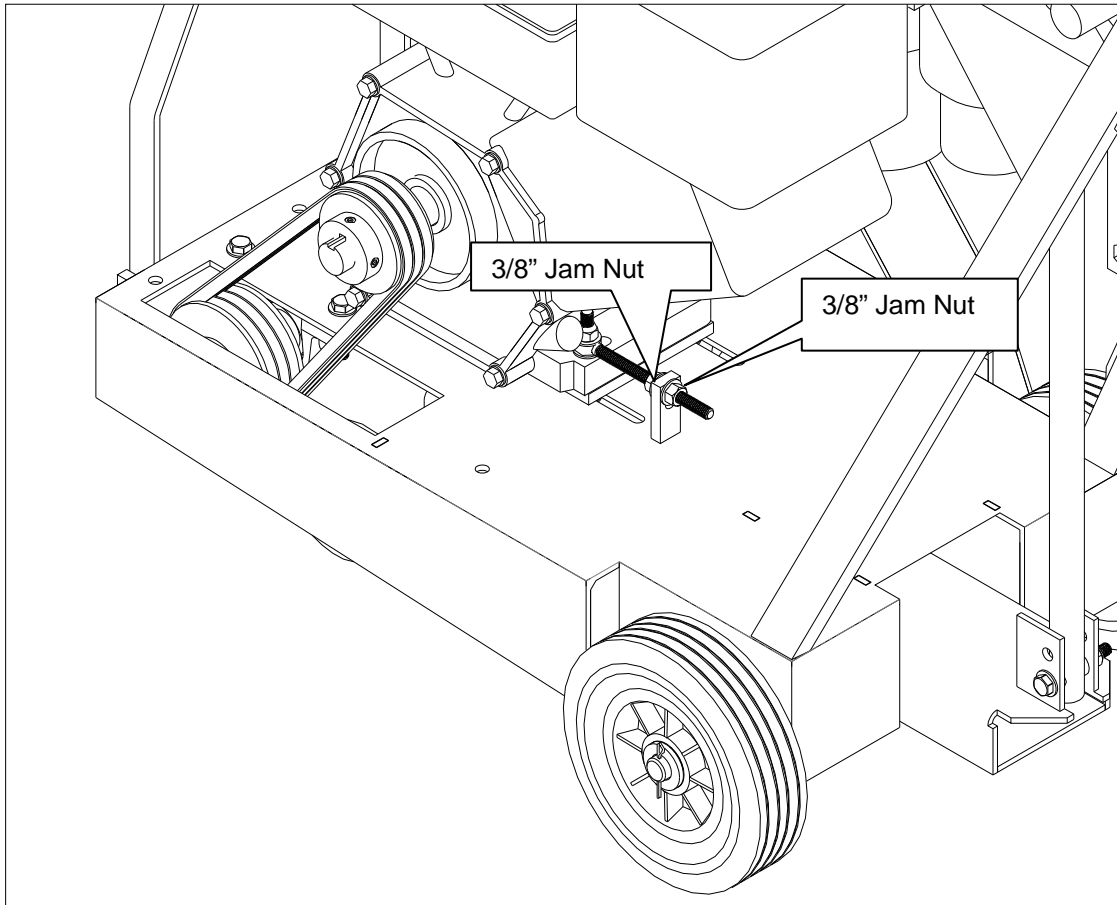

**Figure: C13PE Belt Tensioning Assembly**

6. To apply tension to the Belts tighten (turn clockwise) the rear 3/8" Jam Nut until the required Belt Tension is achieved. To loosen the Belts turn the front 3/8" Jam Nut counter clockwise until the required Belt Tension is achieved. (See **Figure: C13PE Belt Tensioning Jam Nut Directions**).  
NOTE: Do not over tighten the belts as too tight of belts can break Engine Output Shafts, Blade Shafts, Belts, and cause premature Bearing Failures. Failures due to too tight of Belts are not covered by any warranty. Too loose of Belts will cause the Belts to slip under load, and may cause burning of the Belts and is not covered under any warranty.

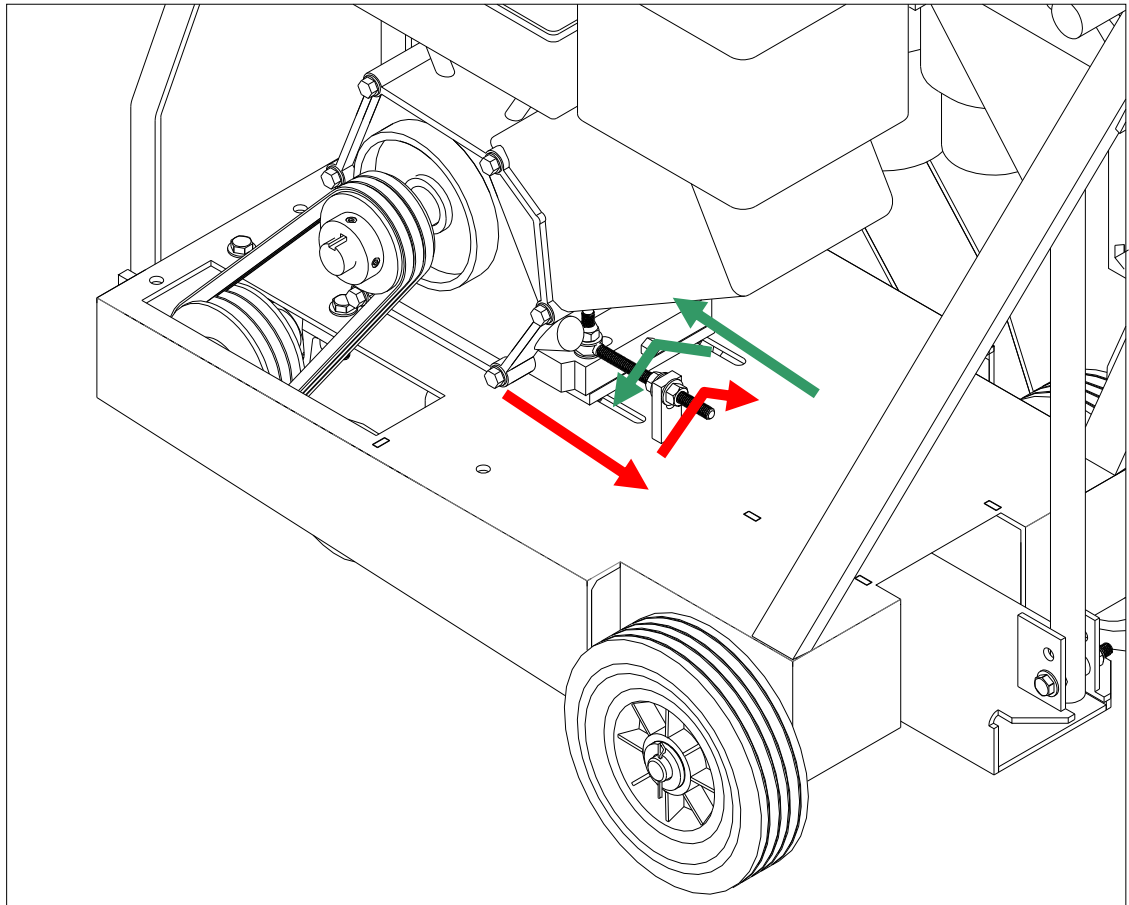

**Figure: C13PE Belt Tensioning Jam Nut Directions**

7. Tighten the four (4) 3/8" Engine Mounting Bolts.
8. Replace the Belt Guard and replace and tighten the 3/8" Belt Guard Retaining Hardware.
9. Run the machine for around 15 minutes and recheck the belt tension. If the Belts slip under load increase the belt tension.

**Remember, too much tension shortens belt and bearing life!**

Check the belt tension frequently during the first day of operation. Check the belt tension periodically thereafter and make any necessary adjustments.

**To align the Pulleys:**

1. Review the locations of the C13PE Belt Tensioning system before proceeding. (See **Figure: C131PE Belt Tensioning System** on page 15).
2. Remove the Belt Guard by loosening and removing the three 3/8 Belt Guard Retaining Bolts.
3. Line up a straight edge along the out side face of both pulleys. (See **Figure: Pulley Alignment** to the right.)

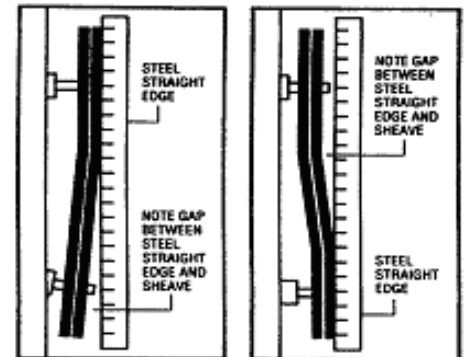

**Figure: Pulley Alignment**

4. Misalignment will show up as a gap between the pulley face and the straight edge.
5. To correct the misalignment move one pulley in or out as required.

**Main Causes of Belt Failures:**

Premature Belt failure can be attributed to the following issues: Tension (too much or too little), Pulley Misalignment, Damaged Pulleys, Improper Handling or Storage, Incorrect Blade Specification for Material Being Cut, and Cutting Too Deep.

<b>Symptom</b>	<b>Possible Cause</b>	<b>Corrective Action</b>
Belt Breakage	Too Much Tension	Re-tension Belts
	Excessive Shock Load	Reduce Load/ Check Blade Specification
	Pulley Out Of Round	Replace Pulley
Burning of Belt	Too Little Belt Tension	Increase Belt Tension
	Excessive Load (Cutting Full Depth)	For Best Performance Only Cut only 1-2" Per Pass
	Containments On Belts	Replace Belts and Find Source Of Containments
	Incorrect Blade Specification	Replace Blade With One Designed For Material Being Cut

Belt Failure Table Continued From Previous Page

<b>Symptom</b>	<b>Possible Cause</b>	<b>Corrective Action</b>
Belt Tearing/Ripping	Pulley Misalignment	Align Pulleys
Belt Rolling Off Pulley	Pulley Misalignment	Align Pulleys
Belt Cracking	Extremely Low Temperature at Startup	Warm Machine Before Use
	Exposure To Chemicals or Lubricates	Locate Source of Containments and Replace Belts.



**Belts are a normal wear item and are not covered under warranty.**



## E. Depth Control

The depth control (raising screw) consists of a threaded rod, which feeds into a steel nut. In order to keep the two parts working smoothly it is necessary to keep the rod free from dirt and sludge as much as possible. Cleaning the threaded rod with a rag after each use will prevent sludge from collecting in the tube assembly and protect the threads. It is a good practice to keep the raising screw threads lubricated, as the slurry generated during cutting will cause premature thread wear. Two (2) revolutions of the Raise Lower Handle will change the depth of cut by ¼”.

The bearing used to support the raising screw should be checked after each use to make sure it is turning freely and lubricated. If the bearing requires re lubrication lithium base grease is recommended.

## F. Inspections and Cleaning

For long life and better machine performance follow the inspection and cleaning schedule below.

		Regular Service Period Performed At Every Indicated Period →						
		After First Hour of Work	Beginning Of Day	During Blade Change	End Of Day	Once A Week	After Failure	After Damage
<b>Whole Machine</b>	Inspect For Damaged or Missing Components	X	X			X	X	X
	Clean		X			X		
<b>Blade Collars</b>	Clean			X				
<b>Belt Tension</b>	Check	X				X	X	X
<b>Water Hose, Water Fittings, and Nozzles</b>	Clean		X			X		
	Inspect		X			X		X
<b>Depth Screw</b>	Grease					X		
<b>Engine</b>	Clean					X		
<b>Reachable Hardware</b>	Tighten					X		
<b>Bearings (Blade Shaft and Depth Control)</b>	Grease*					X		
<b>Wheels</b>	Inspect	X	X			X	X	X

\* = See Bearing Maintenance of This Manual Before Greasing



**Replace any damaged or missing components before using machine.**

## IV. PARTS LIST SECTION

### A. Ordering Information

1. List model number and serial number of machine from the Machine's Serial Number Plate.
2. List UPC number, part number, and Description of part DO NOT use the item number. It is best to use the UPC number when ordering.
3. Wherever alternate parts are shown due to product improvement, inspect the part you have and provide additional description as necessary.
4. Specify mode of shipping desired, such as, parcel post, truck, U.P.S., best way, etc.

For the nearest Norton Clipper distributor call **254-918-2310**

#### Common Replacement Parts

Description	Part Number	UPC
3VX300 Set of three (3)	247304	70184647698
Blade Shaft Nut $\frac{3}{4}$ -16 Left Hand Thread (Operators Right Side Of Saw)	227156	70184673903
Collar Tight	247203	
Collar Loose Assembly (With Pin)	247202	
Bearing Blade Shaft (1) (No Hardware)	227175	70184673905
Wheel 4X1-1/2X3/4 Front (1)	227162	70184674102
Wheel 8X2-1/2X3/4 Rear	227148	70184674103
Wrench Open End	238212	70184628071
Wrench Open End	238213	70184628074

NOTE: All Parts Are Sold As Individual (each) Unless Noted Otherwise

Kitted items are shown in a phantom lined box within the parts drawing.

**Blades Use Only Norton Diamond Blades.** Contact your local Norton Clipper Distributor or our Customer Service at 254-918-2310 for the best blade for the application.

All parts are designated as either Service Parts (S) or Wear Parts (W) in the Type column in the parts listing. Wear parts are worn out through normal use of the machine. The wear period depends on the intensity of use of the machine, handling, and maintenance of the machine. Wear parts must be serviced and eventually changed following the indications of the manufacturer. Any wear due to normal use of the machine will not be considered as a case of warranty for items designated as Wear Parts (W). For best performance and life Genuine Norton Clipper replacement parts should always be used. Changes to part specifications, are subject to change with out notice.

# Depth Control and Depth Lock Group

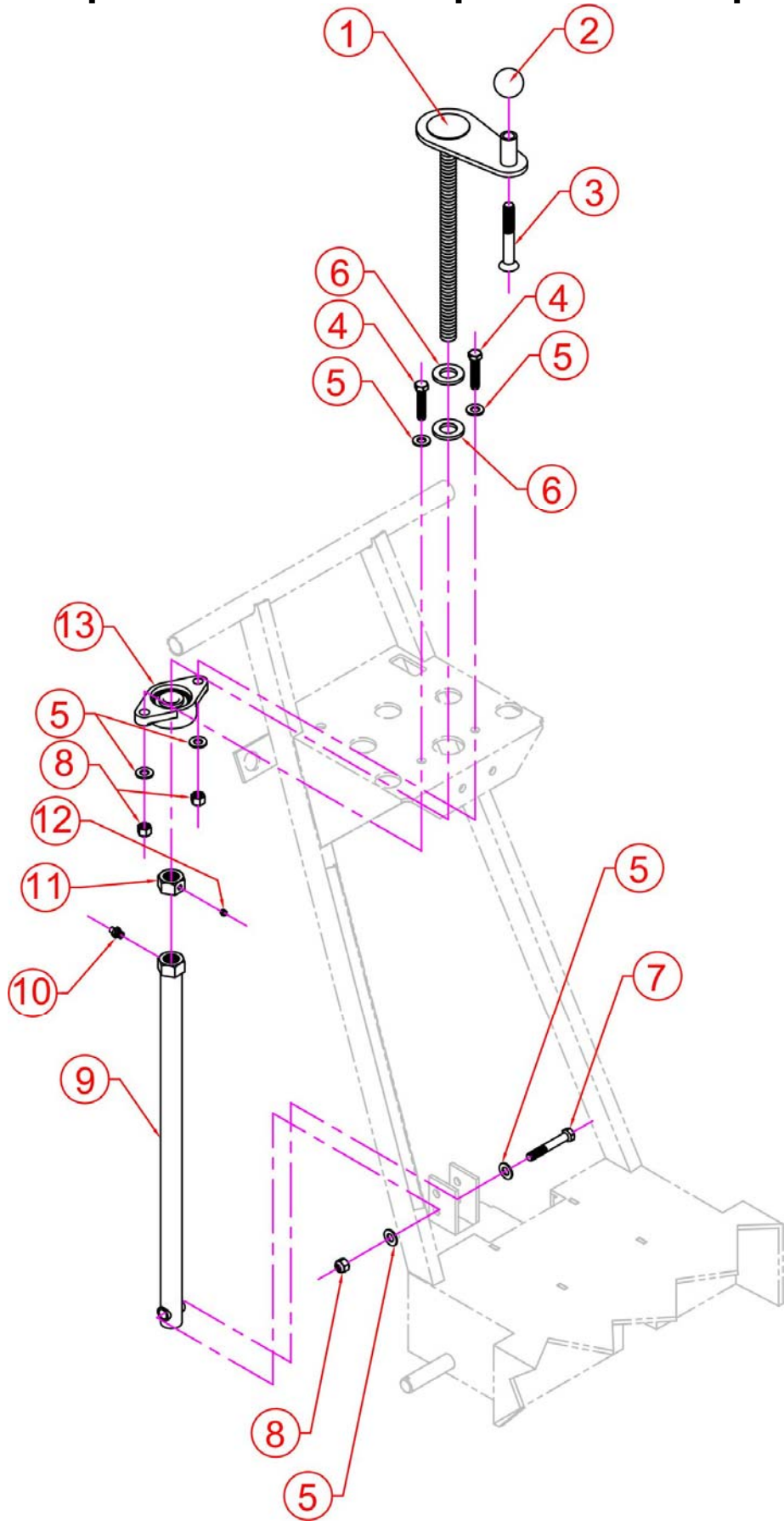

## Depth Control and Depth Lock Group

Item	Part No	UPC No	Description	QTY	Type	NOTES
1	247801	70184647692	Hand Wheel Weldment C13PE	1	S	Hand Wheel Body and Raise Screw
2	238202	70184628279	Ball Knob	1	S	
3	247805	70184647693	Screw 1/2"-13 UNC x 3 Socket Head	1	S	Sold As Each
4	8041056	70184649906	Screw 3/8"-16 UNC x 2-1/2 Hex Head Cap	2	S	Sold As Each
5	8172009	70184650123	Washer 3/8" SAE	6	S	Sold As Each
6	8172015	70184650129	Washer 3/4 SAE	2	S	Sold As Each
7	8041056	70184649906	Screw 3/8"-16 UNC x 2-1/2 Hex Head Cap	1	S	Sold As Each
8	8160003	70184650373	Nut 3/8"-16 UNC Nylock	3	S	Sold As Each
9	238164	70184628181	Depth Screw Tube	1	S	Set Grease Zerk Not Included
10	238234	70184628182	Grease Fitting 1/8" NPT x 11/16"	1	S	1/8" National Pipe Thread Male x 11/16" Long
11	238163	70184628265	Nut 3/4"-10 Hex Head for Depth Screw	2	S	Sold As Each
12	407035	70184682129	Screw 1/4"-20 x 1/2" Set Cup Point	1	S	Sold As Each
13	210071	70184650406	Bearing Flange 3/4" Bore	1	W	Includes Set Screw

Type: S = Service Part, W = Wear Part, All Parts Are Sold As Individual (each) Unless Noted Otherwise

# Blade Guard and Water Control Group

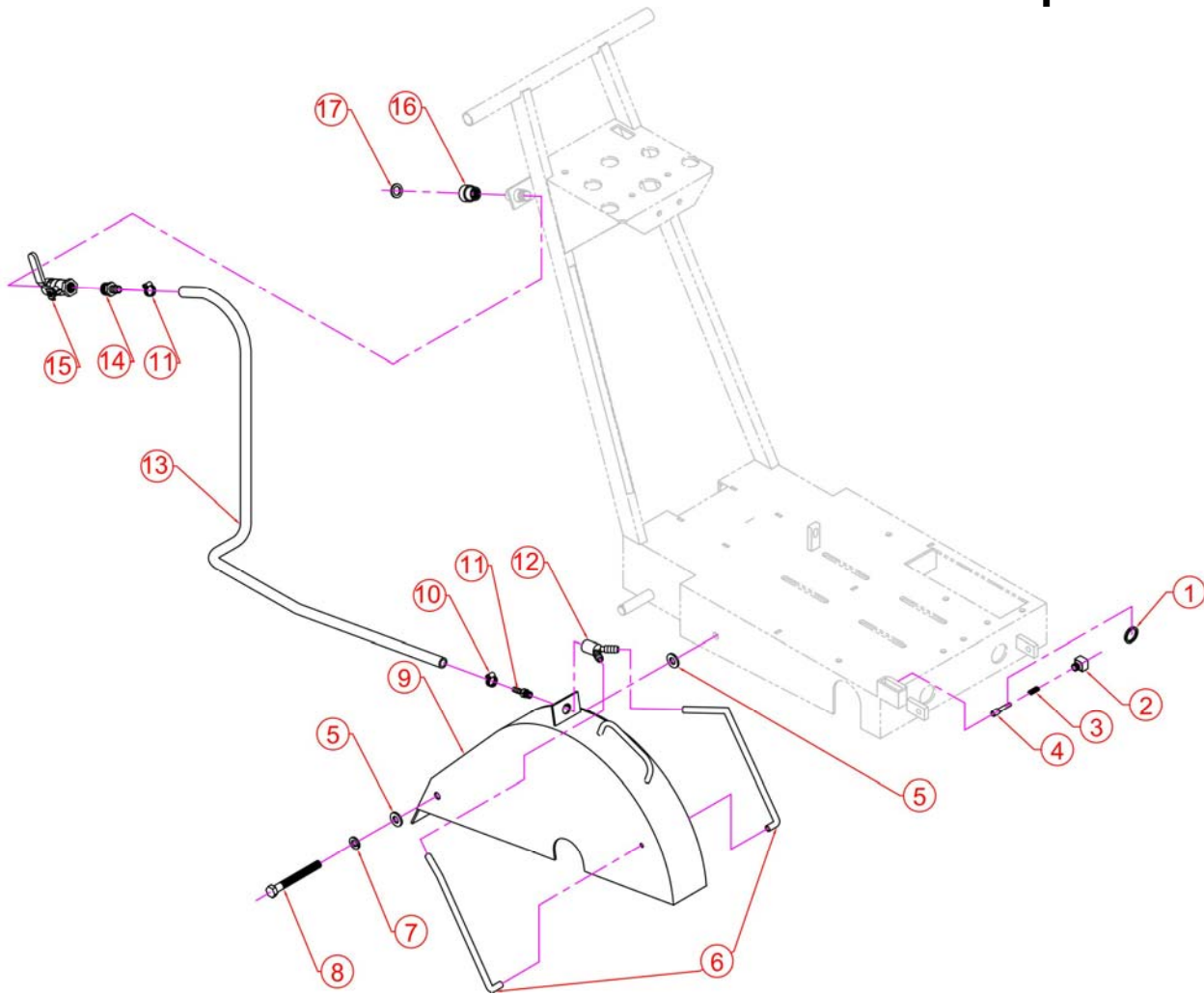

Item	Part No	UPC No	Description	QTY	Type	NOTES
1	238223	70184628501	Ring Guard Lock	1	S	
2	238225	70184628498	Guard Lock	1	S	
3	238224	70184628499	Spring Guard Lock	1	W	
4	238222	70184628500	Pin Guard Lock	1	S	
5	8172011	70184650124	Washer ½" SAE	2	S	Sold as Each
6	082998	70184681299	Nozzel Water (2)	1	W	Set of two (2) Nozzles 5/16" ID x 7/16" OD x 10" Long
7	8177014	70184650154	Washer ½" Spring Lock	1	S	Sold as Each
8	8041107	70184649929	Screw ½"-13 x 4-½" Hex Head Cap	1	S	Sold as Each
9	247106	70184647694	Blade Guard Weldment C13PE	1	S	Blade Guard Weldment Only
10	N1C0113	70184659232	Clamp Hose #10 ½" Wide x ½" TO 29/32"	2	S	
11	9600014	70184650465	Fit Barb Hose 1/4MPT x ½"	1	S	
12	072286	00310004233	Fit Hose "Y"	1	S	
13	0042521	70184683507	Tube 1/2ID X 3/4OD 48" Long	1	S	Use 36
14	9602012	70184626501	Fit Barb Hose ½" MNPT x ½" Male Barb	1	S	½" Male National Pipe Thread Taper x ½" Male Barb Fitting
15	N1C0021	70184659097	Valve Water 1/2"	1	S	
16	N1D0082	70184659115	Swivel Hose ¾" Garden Hose Female x ½" FNPT	1	S	½" Female National Pipe Thread Taper x ¾" Garden Hose Swivel
17	101868	70184650620	Washer Hose 1.00OD x .625	1	W	

Type: S = Service Part, W = Wear Part, All Parts Are Sold As Individual (each) Unless Noted Otherwise

# Engine Group

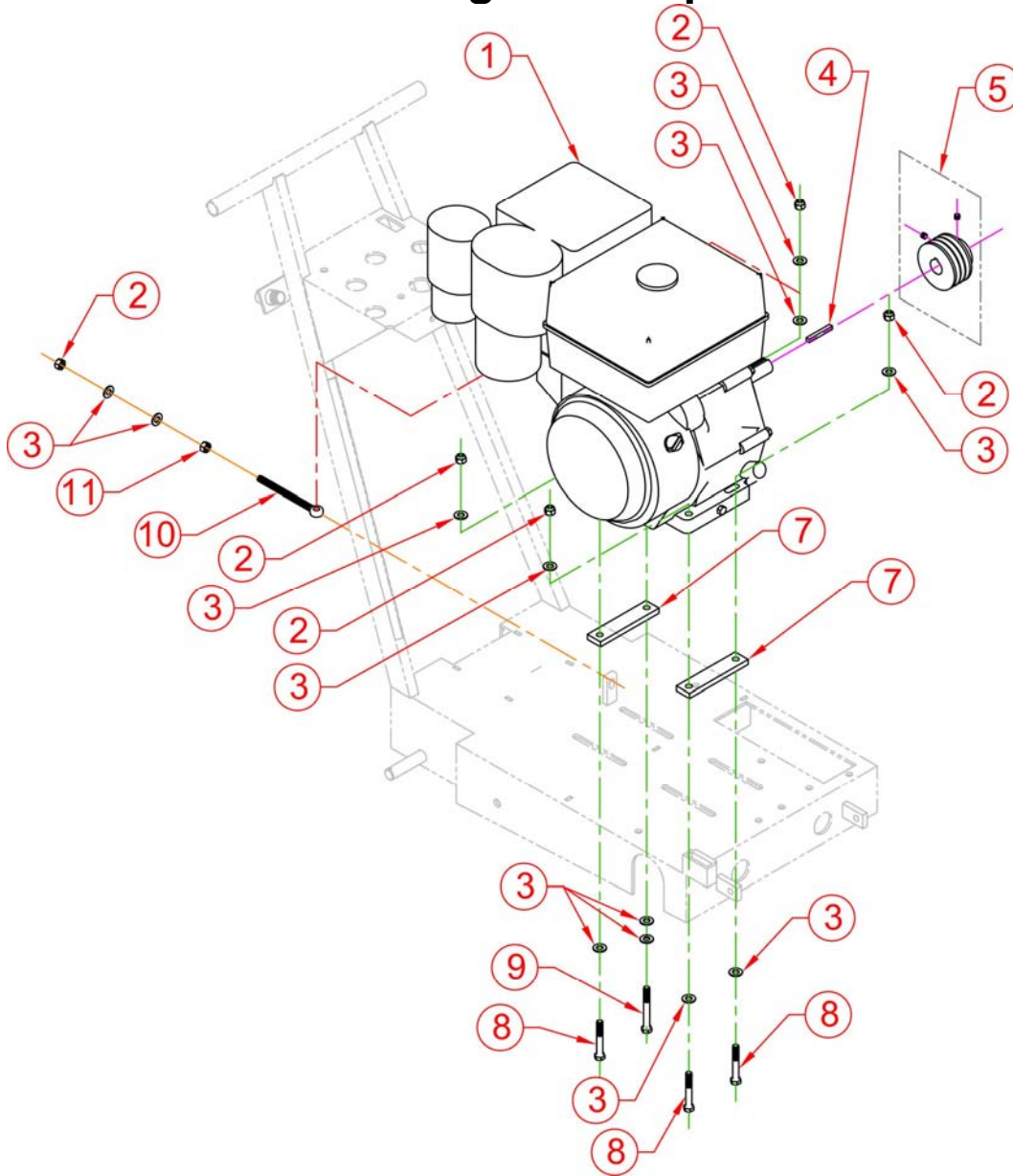

Item	Part No	UPC No	Description	QTY	Type	NOTES
1	123327	70184671620	Engine 13HP Honda Manual Start GX390UT2QXC9	1	S	Engine Only. C13PE Model Honda Specification GX390UT2QXC9
	247301	70184647814	Engine 14HP Subaru Manual Start EX400D50140	1	S	Engine Only. C14PE Model Subaru Specification EX400D50140
2	8160003	70184650373	Nut 3/8"-16 UNC Nylock	4	S	
3	8172009	70184650123	Washer 3/8 SAE	12	S	Sold Individually (1)
4	9201117	70184649705	Key 1/4" x 1-1/2"	1	S	
5	247303	70184647695	Pulley 3.15OD x 1" B 3G 3V	1	S	Includes Set Screws 70184678503 QTY =2
	231239	70184678503	Screw 5/16"-18 UNC x 1/4" Set Cup Point	2	S	Sold Individually (1)
6	247304	70184647698	Belt 3VX300 (3)	1	W	Set of Three (3) Matched 3VX300 Belts
7	247305	70184647696	Spacer Engine C13PE	2	S	Sold Individually (1)
8	8041056	70184649906	Screw 3/8"-16 x 2-1/2" Hex Head Cap	3	S	
9	8041058	70184649907	Screw 3/8"-16 x 3" Hex Head Cap	1	S	
10	247306	70184647699	Eye Bolt 3/8"-16 UNC x 5"	1	S	
11	8142003	70184650349	Nut 3/8"-16 UNC Hex Jam	1	S	

Type: S = Service Part, W = Wear Part, All Parts Are Sold As Individual (each) Unless Noted Otherwise

# Blade Shaft Group

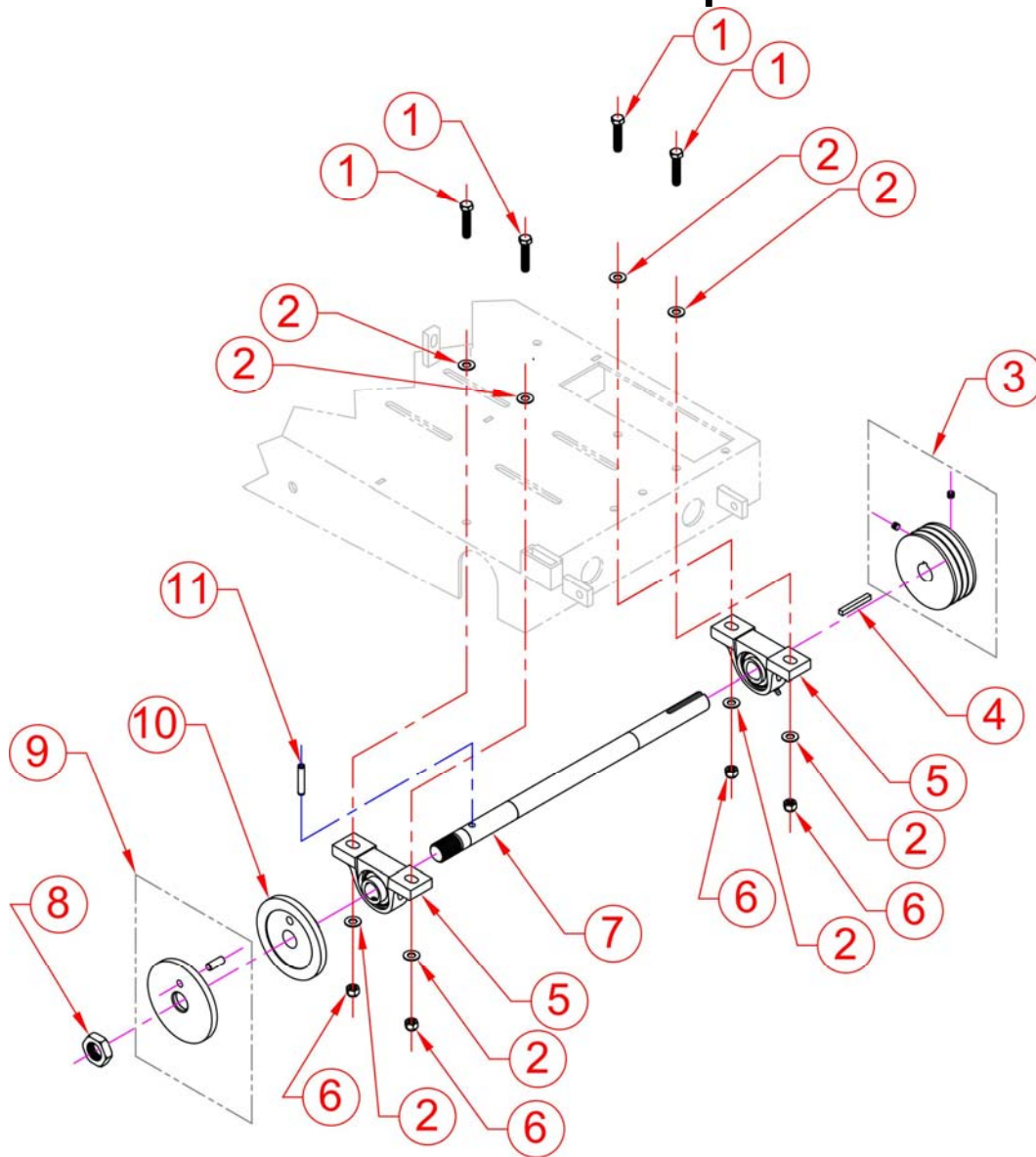

Item	Part No	UPC No	Description	QTY	Type	NOTES
1	8041053	70184649903	Screw 3/8" -16 x 1-3/4" Hex Head Cap	4	S	
2	8172009	70184650123	Washer 3/8" SAE	8	S	
3	247302	70184647700	Pulley 4.12OD x 1" B 3G 3V	1	S	Includes Set Screws 70184678503 QTY =2
	231239	70184678503	Screw 5/16"-18 UNC x 1/4" Set Cup Point	2	S	Sold Individually (1)
4	9201117	70184649705	Key 1/4" x1-1/2"	1	S	
5	227175	70184673905	Bearing Pillow Bock 1"	2	W	Sold Individually (1) Includes Set Screw and Grease Zerk. Does NOT Include: Hardware
6	8160003	70184650373	Nut 3/8"-16 UNC Nylock	4	S	
7	247201	70184647701	Blade Shaft C13PE	1	S	Blade Shaft Only
8	105376	70184627158	Nut 1-14 UNF Hex Jam Left Hand Thread	1	W	
9	247202	70184647702	Loose Collar W/Pin C13PE	1	W	Includes Pin 3/8" x 1" Dowel 70184650531
	9196110	70184650531	Pin 3/8 x 1 Dowel	1	W	
10	247204	70184647703	Tight Collar C13PE	1	W	
11	9195250	70184647704	Pin 5/16" x 1-3/4" Roll	1	W	

Type: S = Service Part, W = Wear Part, All Parts Are Sold As Individual (each) Unless Noted Otherwise



# Raise Axle Group

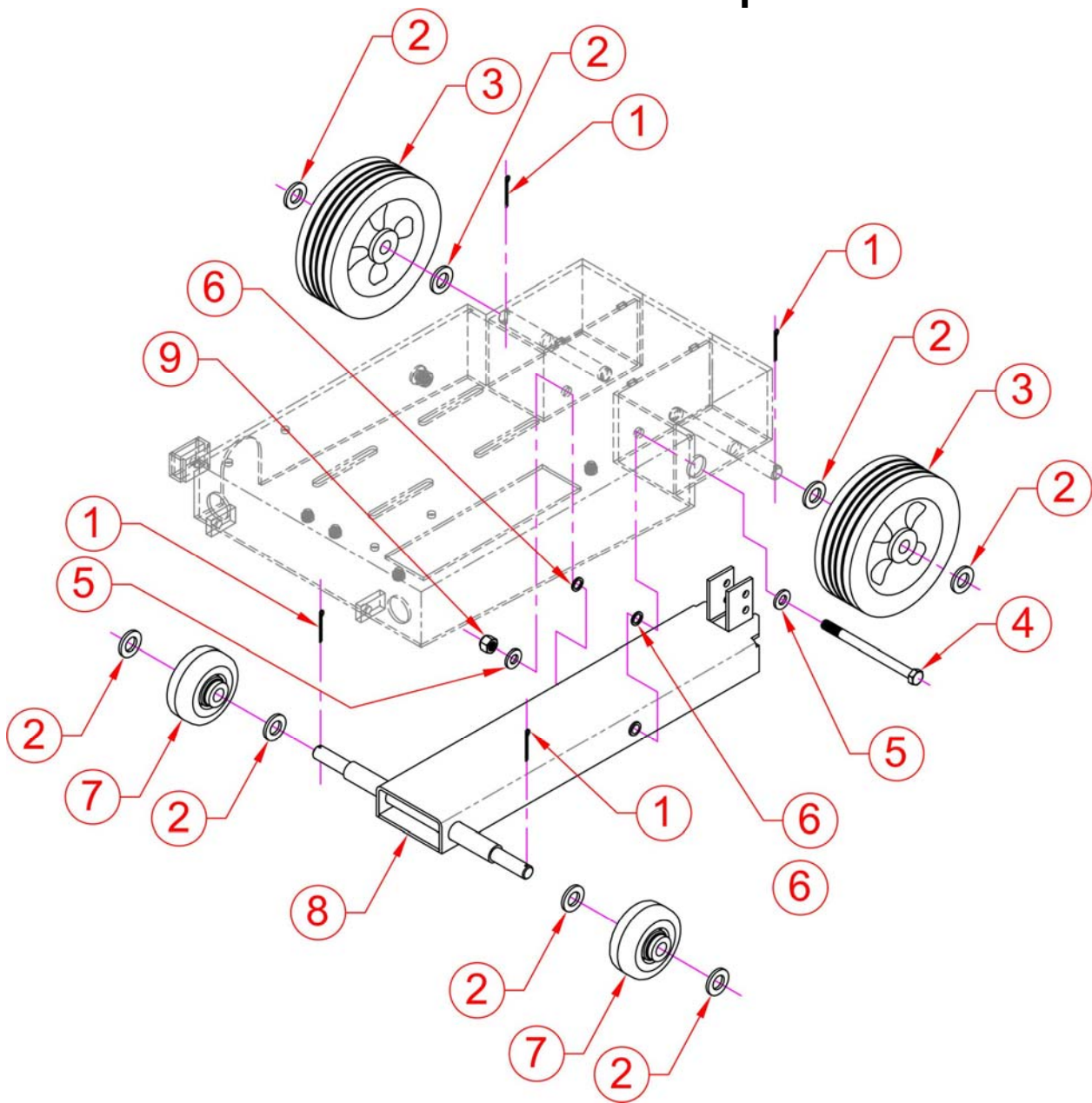

Item	Part No	UPC No	Description	QTY	Type	NOTES
1	227146	70184674553	Pin Cotter 1/8" x 1-1/2"	4	W	
2	8172015	70184650129	Washer 3/4" SAE	8	S	
3	227148	70184674103	Wheel 8" x 2"-1/2" x 3/4" Rear	2	W	Sold Individually (1)
4	247409	70184647705	Screw 1/2"-13 UNC x 6-1/2" Hex Head Cap	1	S	
5	8172009	70184650123	Washer 3/8" SAE	2	S	
6	247406	70184647706	Washer 1/2" Nylon Flat	2	W	
7	227162	70184674102	Wheel 4" x 1-1/2" x 3/4" Front (1)	2	W	Sold Individually (1)
8	247401	70184647708	Raise Axle Weldment C13PE	1	S	Raise Axle Only
9	8160003	70184650373	Nut 3/8"-16 UNC Nylock	1	S	

Type: S = Service Part, W = Wear Part, All Parts Are Sold As Individual (each) Unless Noted Otherwise



## Main Frame and Belt Guard Group

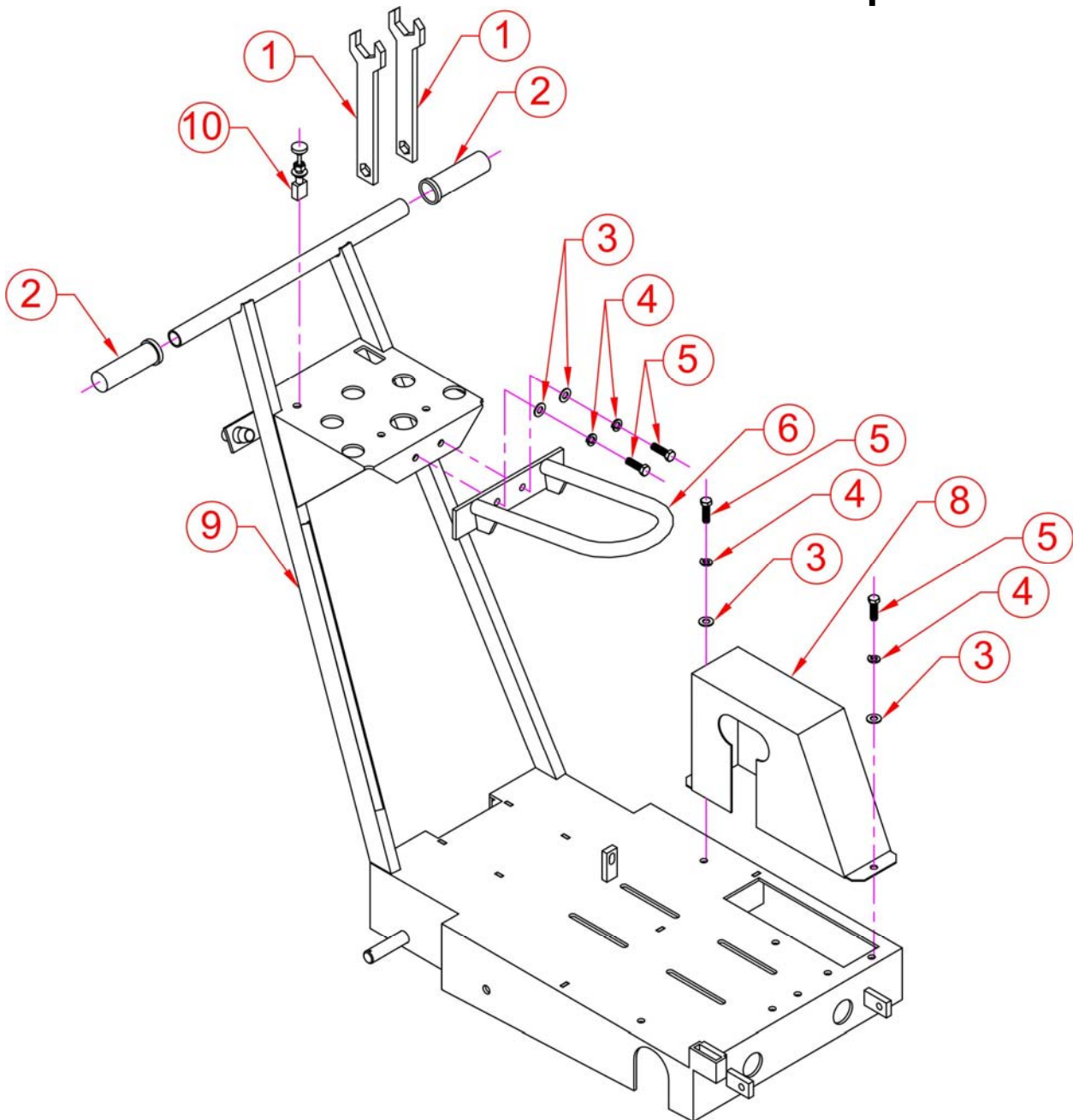

Item	Part No	UPC No	Description	QTY	Type	NOTES
1	238213	70184628074	Wrench Open End 1-1/2"	2	W	
2	227101	70184674393	Hand Grip	2	W	Sold Individually (1)
3	8172009	70184650123	Washer 3/8" SAE	4	S	Sold Individually (1)
4	8177012	70184650149	Washer 3/8" Spring Lock	4	S	Sold Individually (1)
5	8041051	70184649901	Screw 3/8"-16 X 1-1/4" Hex Head Cap	4	S	Sold Individually (1)
6	247016	70184647708	Lifting Bale Weldment C13PE	1	S	
7	247601	70184647709	Belt Guard Weldment C13PE	1	S	
9	247001	70184647710	Main Frame Weldment C13PE	1	S	Main Frame Weldment Only
10	238229	70184628277	Emergency Kill Switch	1	W	

Type: S = Service Part, W = Wear Part, All Parts Are Sold As Individual (each) Unless Noted Otherwise

# Front Pointer Group

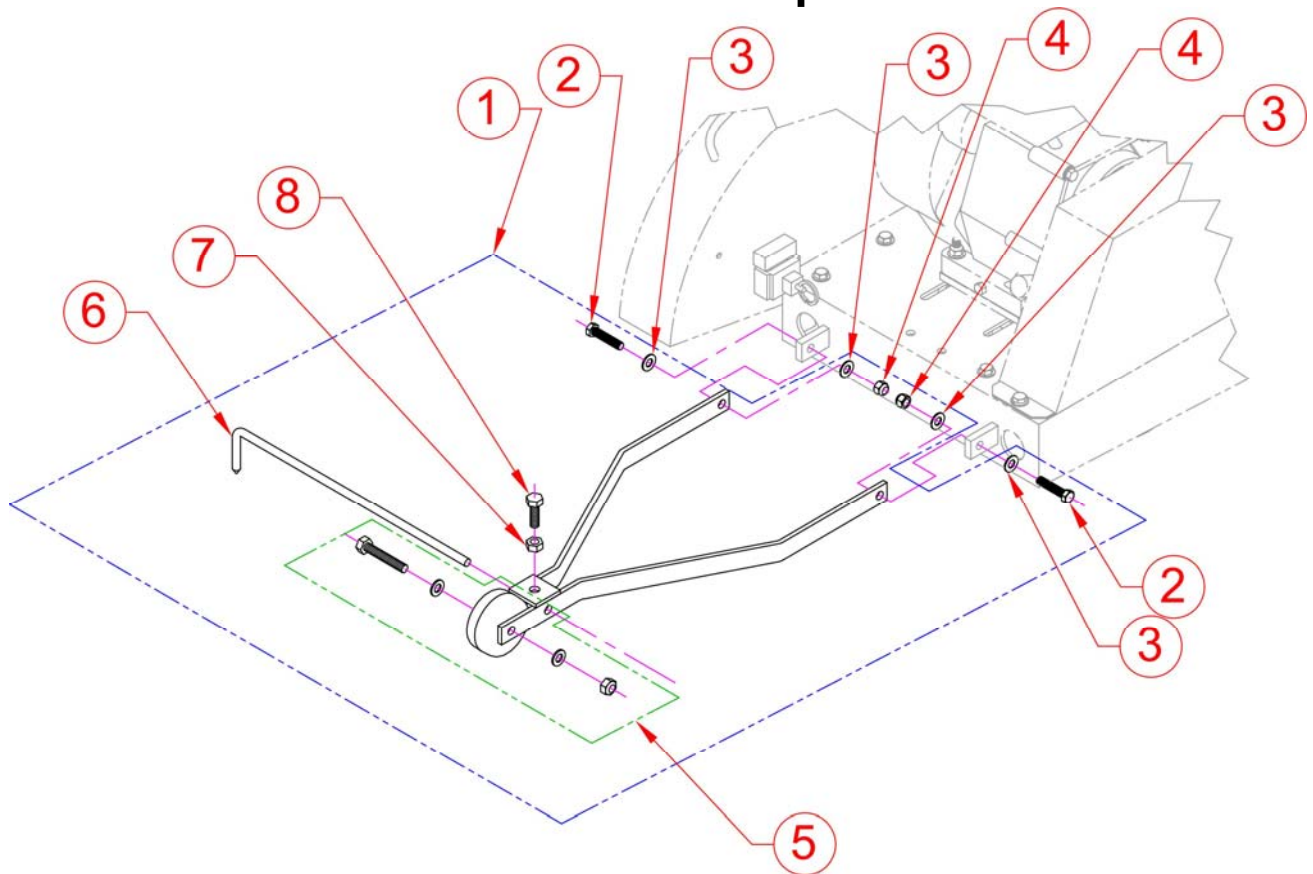

Item	Part No	UPC No	Description	QTY	Type	NOTES
1	232127	00310024051	Pointer Assembly	1	S	Includes: Front Pointer Rod, Pointer Frame, Wheel, and Hardware. NOTE: Hardware in 00310024051 is metric but will function without any issues. Pointer Frame Weldment is only available as part of 00310024051
2	8041053	70184649903	Screw 3/8"-16 X 1-3/4" Hex Head Cap	2	S	
3	8172009	70184650123	Washer 3/8" SAE	4	S	
4	8160003	70184650373	Nut 3/8-16 Hex Lock	2	S	
5	232126	00310004622	Wheel Pointer W/Hardware	1	S	
6	232125	00310004244	Pointer Rod	1	S	Pointer Rod Only
7	237242	70184627482	Screw M10 X 50 1.5 DIN933 Hex Head Cap Full Thread	1	S	
8	27006	70184681615	Nut M10 1.5 DIN934 Hex Jam	1	S	

Type: S = Service Part, W = Wear Part, All Parts Are Sold As Individual (each) Unless Noted Otherwise

# NOTES:

Page Intentional Left Blank

## **Saint-Gobain Abrasives**

2770 West Washington

Stephenville, TX 76401

Phone: 254-918-2310

Fax: 254-918-2312

The Norton logo consists of the word "NORTON" in a bold, italicized, white sans-serif font, centered within a blue parallelogram shape that is wider at the top and narrower at the bottom.

# **NORTON**

## **SAINT-GOBAIN**

---

# **WARNING**

**Some dust created by power sanding, sawing, grinding, drilling, and other construction activities contains chemicals known to cause cancer, birth defects or other reproductive harm. Some examples of these chemicals are:**

- **Lead from lead-based paints,**
- **Crystalline silica from bricks and cement and other masonry products, and**
- **Arsenic and chromium from chemically-treated lumber.**

**Your risk from these exposures varies, depending on how often you do this type of work. To reduce your exposure to these chemicals: work in a well ventilated area, and work with approved safety equipment, such as those dust masks that are specially designed to filter out microscopic particles.**