



BRIDGE AND JOB SITE SAW MACHINES



AVAILABLE BLADES



ACCESSORIES

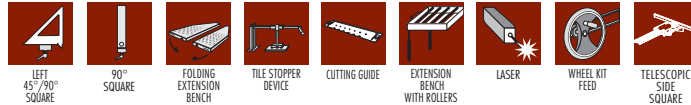

PACKAGE

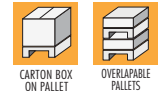

TECHNICAL CHARACTERISTICS

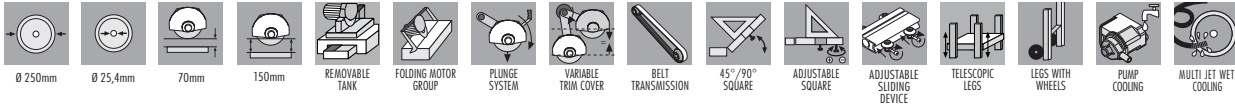

- For cutting granite, marble, porcelain, single and double fired, bricks, cement, etc...
- Maximum length of cut 85 cm (33 1/2").
- Maximum thickness of cut: 80 mm (3 1/8") in single pass; 150 mm (6") in double pass.
- Maximum blade diameter Ø 250 mm (10"); smallest blade diameter Ø 230 mm (9").
- Adjustable cutting depth.
- Tilting motor assembly for bevel cuts from 0° to 45°.
- Belt driven system optimizes motor torque and cutting capacity. Gear ratio of motor to disc 1,4 ÷ 1. Drive belt type poly V.
- Cast and extruded aluminum framework.

- Easy-to-remove polypropylene tank for easy cleaning. Capacity: 38 lt (10 Gal).
- Heavy duty water pump and (2) jet nozzles (front or rear mounted) provide superior blade cooling.
- Sliding motor assembly with cast aluminum housing provided with 4 re-adjustable pulleys (double bearings). Extruded aluminum rail.
- Re-adjustable square for long lasting precision.
- Telescopic legs provided with safety device to prevent collapsing.
- Floating blade guard remains in contact with tile to provide extra safety during operation.
- Pivoting blade guard remains parallel with tile to ensure maximum cutting depth.
- Equipped with: diamond disc Ø 250 mm (10") for porcelain. Wheels kit for easy transport. Key kit, wrench, manual.

MODEL SPECIFICATIONS

Part No.	Barcode	Box	Lightning Bolt	M	Motor	Motor	Blade	Blade	
424ADV	8024648054791	1	230 V 50Hz	Single-phase	1,5 HP / 1,1 kW	2800	250 mm	10"	2000
424ADV 60	8024648055941	1	230 V 60Hz	Single-phase	1,5 HP / 1,1 kW	3360	250 mm	10"	2400
424ADV US	8024648054807	1	110 V 60Hz	Single-phase	1,3 HP / 1 kW	3360	250 mm	10"	2400
424ADV GB	8024648055934	1	115 V 50Hz	Single-phase	1,3 HP / 1 kW	2800	250 mm	10"	2000

CUTTING SPECIFICATIONS AND MACHINE DIMENSIONS/WEIGHT

Model	Blade	Thickness	Thickness	Length	Width	Height	Weight	Dimensions	Weight	
PIKUS 85 ADV	250 mm 10"	80 mm 3 1/8"	55 mm 2 1/8"	85 cm 33 1/2"	∞	60x60 cm 23 5/8"x23 5/8"	125x70xh 79 cm 50"x27"x h 31"	60 Kg 132 lbs	150x73xh 95cm 59"x29"x h 37"	78 Kg 172 lbs



PIKUS 105 ADVANCED

BRIDGE AND JOB SITE SAW MACHINES



AVAILABLE BLADES

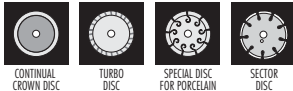

ACCESSORIES

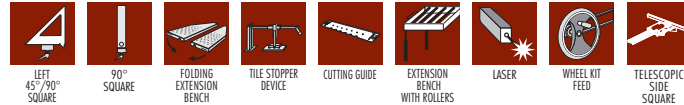

PACKAGE

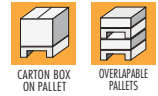

TECHNICAL CHARACTERISTICS

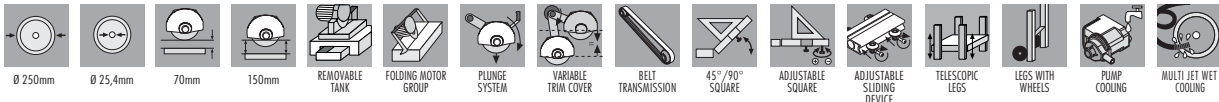

- For cutting granite, marble, porcelain, single and double fired, bricks, cement, etc...
- Maximum length of cut 105 cm (41 3/8").
- Maximum thickness of cut: 80 mm (3 1/8") in single pass; 150 mm (6") in double pass.
- Maximum blade diameter Ø 250 mm (10"); smallest blade diameter Ø 230 mm (9").
- Adjustable cutting depth.
- Tilting motor assembly for bevel cuts from 0° to 45°.
- Belt driven system optimizes motor torque and cutting capacity. Gear ratio of motor to disc 1,4 ÷ 1. Drive belt type poly V.
- Cast and extruded aluminum framework.

- Easy-to-remove polypropylene tank for easy cleaning. Capacity: 38 lt (10 Gal).
- Heavy duty water pump and (2) jet nozzles (front or rear mounted) provide superior blade cooling.
- Sliding motor assembly with cast aluminum housing provided with 4 re-adjustable pulleys (double bearings). Extruded aluminum rail.
- Re-adjustable square for long lasting precision.
- Telescopic legs provided with safety device to prevent collapsing.
- Floating blade guard remains in contact with tile to provide extra safety during operation.
- Pivoting blade guard remains parallel with tile to ensure maximum cutting depth.
- Equipped with: diamond disc Ø 250 mm (10") for porcelain. Wheels kit for easy transport. Key kit, wrench, manual.

MODEL SPECIFICATIONS

Part No.	Barcode	Box	Lightning Bolt	Motor	Motor	Motor	Blade	Blade	
423ADV	8024648055163	1	230 V 50Hz	Single-phase	1,5 HP / 1,1 kW	2800	250 mm	10"	2000
423ADV 60	8024648055927	1	230 V 60Hz	Single-phase	1,5 HP / 1,1 kW	3360	250 mm	10"	2400
423ADV US	8024648055910	1	110 V 60Hz	Single-phase	1,3 HP / 1 kW	3360	250 mm	10"	2400
423ADV GB	8024648055903	1	115 V 50Hz	Single-phase	1,3 HP / 1 kW	2800	250 mm	10"	2000

CUTTING SPECIFICATIONS AND MACHINE DIMENSIONS/WEIGHT

Model	Blade	Thickness	Thickness	Length	Width	Height	Weight	Box	Weight	
PIKUS 105 ADV	250 mm 10"	80 mm 3 1/8"	55 mm 2 1/8"	105 cm 41 3/8"	∞	75x75 cm 29 1/2"x29 1/2"	145x70xh 79 cm 57"x27"x h 31"	64 Kg 141 lbs	150x73xh 95cm 59"x29"x h 37"	82 Kg 181 lbs





BRIDGE AND JOB SITE SAW MACHINES



AVAILABLE BLADES

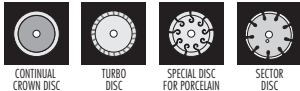

ACCESSORIES

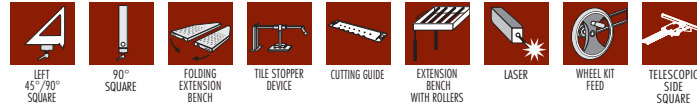

PACKAGE



TECHNICAL CHARACTERISTICS



- For cutting granite, marble, porcelain, single and double fired, bricks, cement, etc...
- Maximum length of cut 130 cm (51 1/8").
- Maximum thickness of cut: 80 mm (3 1/8") in single pass; 150 mm (6") in double pass.
- Maximum blade diameter Ø 250 mm (10"); smallest blade diameter Ø 230 mm (9").
- Adjustable cutting depth.
- Tilting motor assembly for bevel cuts from 0° to 45°.
- Belt driven system optimizes motor torque and cutting capacity. Gear ratio of motor to disc 1,4 ÷ 1. Drive belt type poly V.
- Cast and extruded aluminum framework.

- Easy-to-remove polypropylene tank for easy cleaning. Capacity: 38 lt (10 Gal).
- Heavy duty water pump and (2) jet nozzles (front or rear mounted) provide superior blade cooling.
- Sliding motor assembly with cast aluminum housing provided with 4 re-adjustable pulleys (double bearings). Extruded aluminum rail.
- Re-adjustable square for long lasting precision.
- Telescopic legs provided with safety device to prevent collapsing.
- Floating blade guard remains in contact with tile to provide extra safety during operation.
- Pivoting blade guard remains parallel with tile to ensure maximum cutting depth.
- Equipped with: diamond disc Ø 250 mm (10") for porcelain. Wheels kit for easy transport. Key kit, wrench, manual.

MODEL SPECIFICATIONS

Part No.	Barcode	Box	Lightning Bolt	M	Motor	Motor	Blade	Blade	Blade
425ADV	8024648055170	1	230 V 50 Hz	Single-phase	1,5 HP/1,1 kW	2800	250 mm	10"	2000
425ADV 60	8024648055972	1	230 V 60 Hz	Single-phase	1,5 HP/1,1 kW	3360	250 mm	10"	2400
425ADV US	8024648055965	1	110 V 60 Hz	Single-phase	1,3 HP/1 kW	3360	250 mm	10"	2400
425ADV GB	8024648055958	1	110 V 50 Hz	Single-phase	1,3 HP/1 kW	2800	250 mm	10"	2000

CUTTING SPECIFICATIONS AND MACHINE DIMENSIONS/WEIGHT

Model	Blade	Thickness	Thickness	Length	Width	Table	Table	Weight	Dimensions	Weight
PIKUS 130 ADV	250 mm 10"	80 mm 3 1/8"	55 mm 2 1/8"	130 cm 51 1/8"	∞	90 x 90 cm 35 3/8"x35 3/8"	170x70xh 79 cm 68"x27"x h 31"	78 Kg 172 lbs	180x75xh 105cm 71"x30"x h 42"	100 Kg 220 lbs

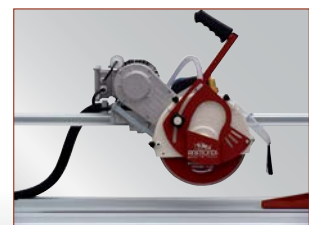
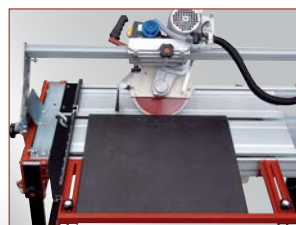
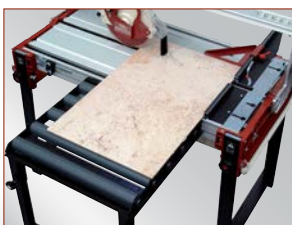

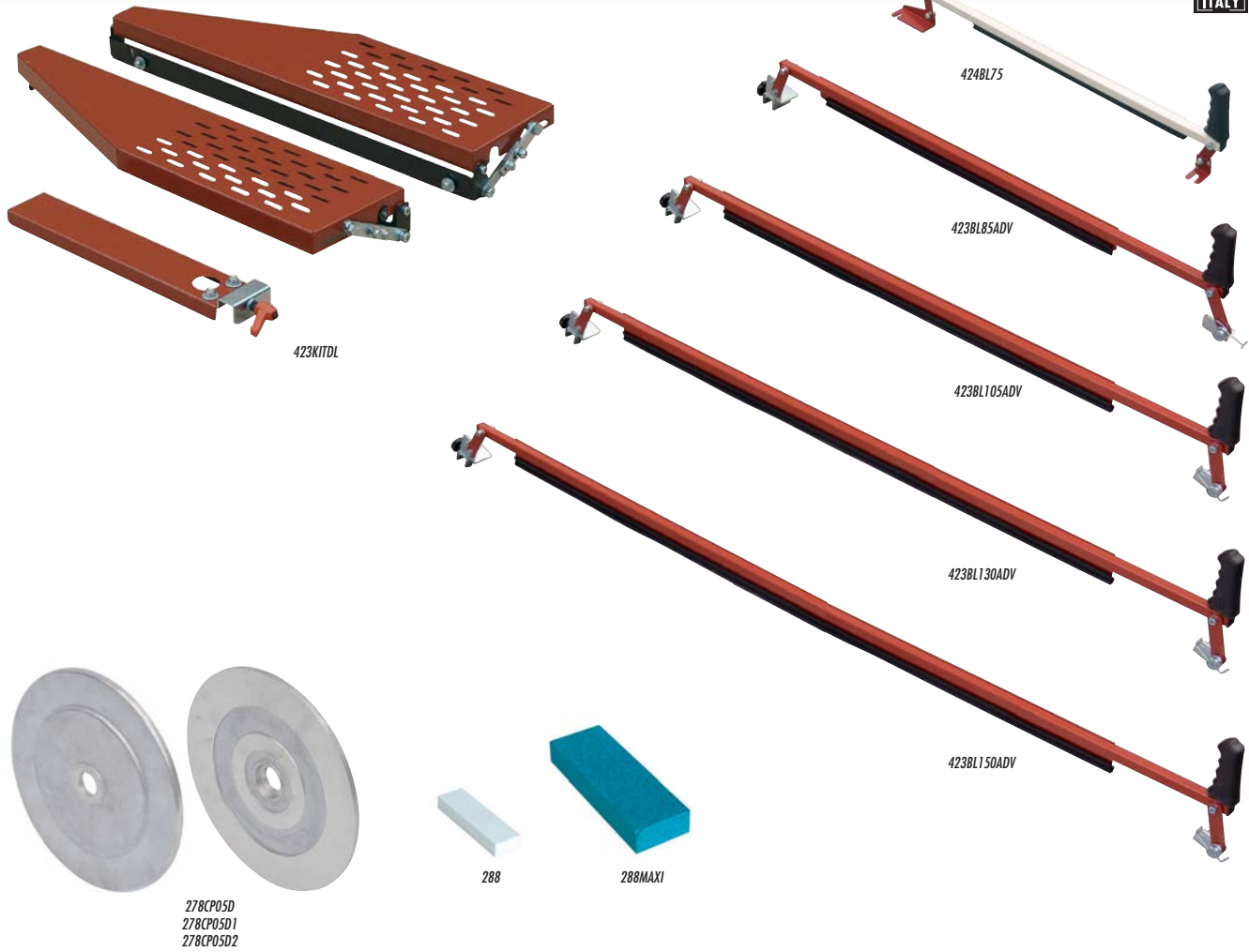

Part No.			Description				
423KITDL	8024648010476	1	Optional kit: folding extension tables and 90° left square	71x22xh 10 cm	28"x8 5/8"xh 4"	5 Kg	11 lbs
424BL75	8024648006622	1	Tile holder for Pikus 75	89x24xh 20 cm	35"x9 1/2"xh 7 7/8"	1,8 Kg	4 lbs
423BL85ADV	8024648055293	1	Tile holder for Pikus 85 ADV and Zoe 85 ADV	97x24xh 20 cm	46"x9 1/2"xh 7 7/8"	2,3 Kg	5.0 lbs
423BL105ADV	8024648056757	1	Tile holder for Pikus 105 ADV, SMS 100, Zoe 105 ADV	117x24xh 20 cm	47 1/4"x9 1/2"xh 7 7/8"	2,6 Kg	5.7 lbs
423BL130ADV	8024648066459	1	Tile holder for Pikus 130 ADV, SMS 125, Zoe 130 ADV	153x24xh 20 cm	60"x9 1/2"xh 7 7/8"	3 Kg	6.6 lbs
423BL150ADV	8024648071187	1	Tile holder for SMS150 and Zoe 150 ADV	178x24xh 20 cm	60"x9 1/2"xh 7 7/8"	3,5 Kg	7.7 lbs
288	8024648004178	5	Dressing 30 x 100 x h 15 mm (1 3/16"x 4"xh 5/8")	11x10xh 4 cm	4 3/8"x4"xh 2 3/4"	100 gr	3.5 oz
288MAXI	8024648004185	1	Dressing 55 x 160 x h 25 mm (2 3/16"x 6"xh 1")	17x12xh 6 cm	6 5/8"x4 3/4"xh 2 1/8"	250 gr	8.8 oz
278CP05D	8024648059390	2	Flanges (pair) Ø 200 mm (78") for CM 150 and CM 100	-	-	-	-
278CP05D1	8024648079060	2	Flanges (pair) Ø 200 mm (78") for Zoe ADV	-	-	-	-
278CP05D2	8024648079077	2	Flanges (pair) Ø 200 mm (78") for SMS and Maxicut	-	-	-	-

Part No.	EXPLOIT		PIKUS 75	PIKUS ADV			SMS			MAXICUT	ZOE ADV				CM		SA25	SA80	SA09	SHERPA
	50	70		85	105	130	100	125	150		85	105	130	150	100	150				
423KITDL	•	•	•	•	•	•	•	•	•	•	•	•	•	•	-	-	-	-	-	
424BL75	-	-	•	-	-	-	-	-	-	•	-	-	-	-	-	-	-	-	-	
423BL85ADV	-	-	-	•	-	-	-	-	-	-	•	-	-	-	-	-	-	-	-	
423BL105ADV	-	-	-	-	•	-	-	-	-	-	•	-	-	-	-	-	-	-	-	
423BL130ADV	-	-	-	-	-	•	-	-	-	-	-	•	-	-	-	-	-	-	-	
423BL150ADV	-	-	-	-	-	-	•	-	-	-	-	-	•	-	-	-	-	-	-	
288	•	•	•	•	•	•	•	•	•	•	•	•	•	•	•	•	•	•	•	
288MAXI	•	•	•	•	•	•	•	•	•	•	•	•	•	•	•	•	•	•	•	
278CP05D	-	-	-	-	-	-	-	-	-	•	•	•	•	•	•	•	•	•	•	
278CP05D1	-	-	-	-	-	-	-	-	-	•	•	•	•	•	•	•	•	•	•	
278CP05D2	-	-	-	-	-	-	•	•	•	•	•	•	•	•	•	•	•	•	•	

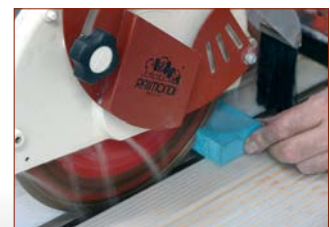



ACCESSORIES FOR SAW MACHINES

MADE IN ITALY

BRIDGE AND JOB SITE SAW MACHINES



Part No.			Description				
374RU5D40	8024648074317	1	Rolling side table (5 rollers) - 60 cm (2') length	75x60xh 26 cm	29 1/2" x 23 5/8" xh 10"	23.0 Kg	50.6 lbs
374RU10D40	8024648074300	1	Rolling side table (10 rollers) - 100 cm (3' 3") length	108x60xh 26 cm	42 1/2" x 23 5/8" xh 10"	27.6 Kg	60.8 lbs
374SQU5PE	8024648011831	1	Extension bench with square for "CM100"	132x79xh 24 cm	52" x 31" xh 9 1/2"	31,4 Kg	69 lbs
379SQU5PE	8024648011824	1	Extension bench with square for "CM150"	192x82xh 35 cm	75 5/8" x 32 1/4" xh 13 3/4"	33,6 Kg	74 lbs
192SQ21A	8024648011893	1	Sliding square 45° for extension bench CM100 - CM150	20x22xh 4 cm	7 7/8" x 8 5/8" xh 1 1/2"	900 gr	31.8 oz
191CL03A	8024648011848	1	Set-square for CM150	153x34xh 7 cm	60 1/4" x 13 3/8" xh 2 3/4"	12,5 Kg	27.5 lbs
191CL04A1	8024648080998	1	Telescopic set-square 90°/45° for Pikus Adv, SMS, Zoe Adv, Maxicut	80x33xh 21 cm	31 1/2" x 13" xh 8 1/4"	9 Kg	19.8 lbs
379BLOPIA	8024648011862	1	Tile-holder for CM150	172x42xh 32 cm	67 3/4" x 16 1/2" xh 13"	8,6 Kg	19 lbs
192SQ03A	8024648014986	1	Sliding square 90°	42x7xh 5 cm	16 1/2" x 2 3/4" xh 2"	900 gr	31.8 oz
192SQ06A	8024648014931	1	Left sliding square 45°/90°	29x22xh 7 cm	11 1/2" x 8 5/8" xh 2 3/4"	900 gr	31.8 oz
191CL04A	8024648056122	1	Side square for Pikus ADV, SMS, Zoe ADV	81x45xh 13 cm	32" x 17 3/4" xh 5"	4,5 Kg	10 lbs
191CL05A	8024648058003	1	Side square for rolling side tables and for SA25 / SA80	54x39xh 9 cm	21" x 15 3/8" xh 3 1/2"	3,6 Kg	7.9 lbs

Part No.	EXPLOIT		PIKUS 75	PIKUS ADV			SMS			MAXICUT	ZOE ADV				CM		SA25	SA80	SA09	SHERPA
	50	70		85	105	130	100	125	150		85	105	130	150	100	150				
374RU5D40	-	-	-	•	•	•	•	•	•	•	•	•	•	•	•	-	-	-	-	
374RU10D40	-	-	-	•	•	•	•	•	•	•	•	•	•	•	•	-	-	-	-	
374SQU5PE	-	-	-	-	-	-	-	-	-	-	-	-	-	-	-	-	-	-	-	
379SQU5PE	-	-	-	-	-	-	-	-	-	-	-	-	-	-	-	-	-	-	-	
192SQ21A	-	-	-	-	-	-	-	-	-	-	-	-	-	-	-	-	-	-	-	
191CL03A	-	-	-	-	-	-	-	-	-	-	-	-	-	-	-	-	-	-	-	
191CL04A1	-	-	-	•	•	•	•	•	•	•	•	•	•	•	•	-	-	-	-	
379BLOPIA	-	-	-	-	-	-	-	-	-	-	-	-	-	-	-	-	-	-	-	
192SQ03A	•	•	•	•	•	•	•	•	•	•	•	•	•	•	•	-	-	-	-	
192SQ06A	•	•	•	•	•	•	•	•	•	•	•	•	•	•	•	-	-	-	-	
191CL04A	-	-	-	•	•	•	•	•	•	•	•	•	•	•	•	-	-	-	-	
191CL05A	-	-	-	•	•	•	•	•	•	•	•	•	•	•	•	-	-	-	-	

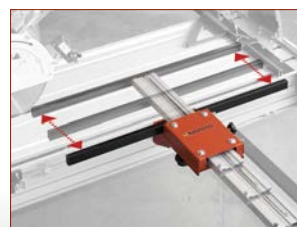
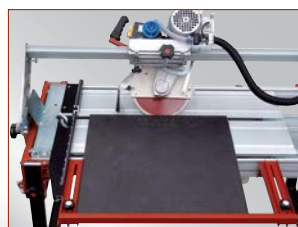
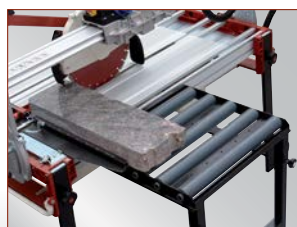

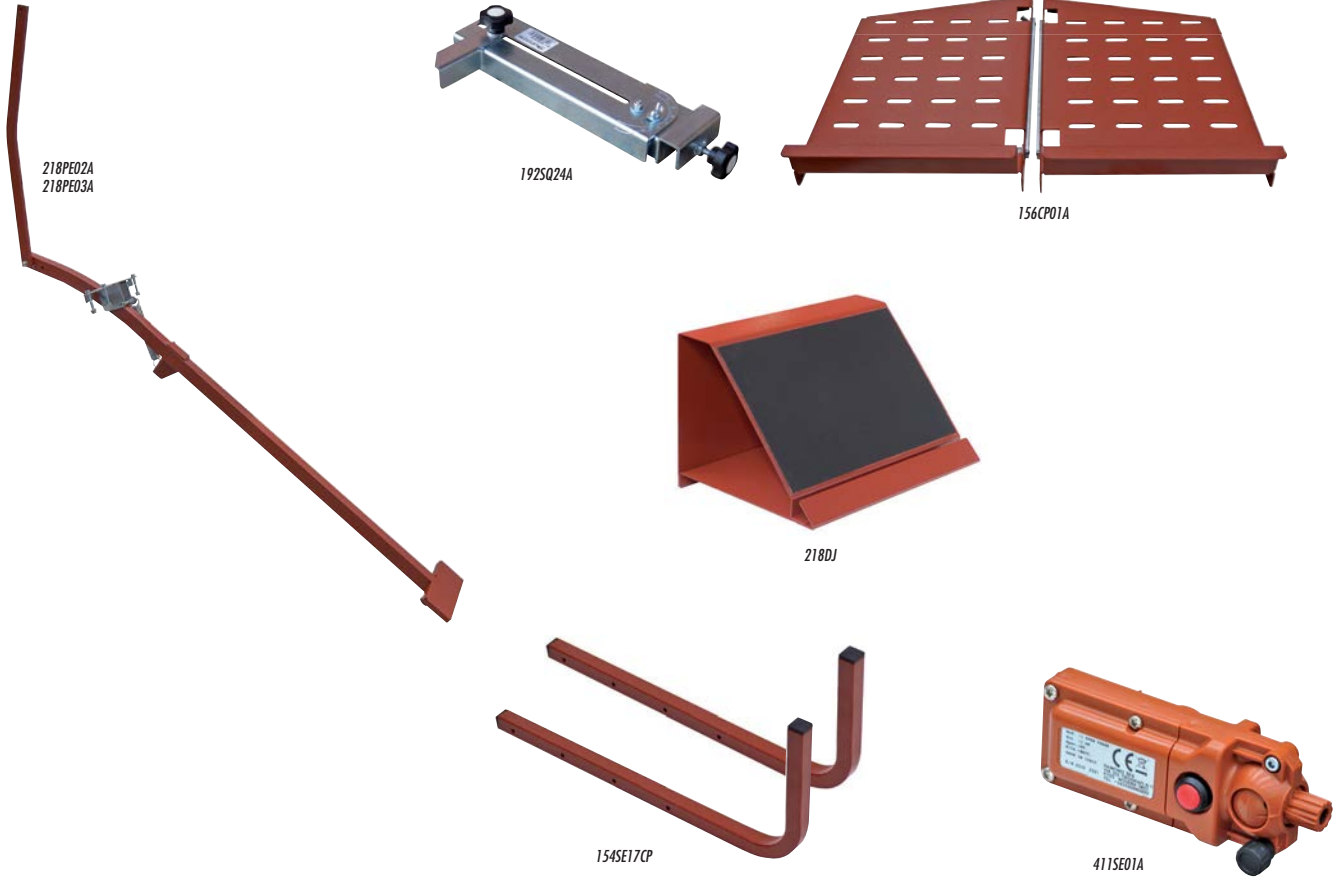

Part No.			Description				
218PE02A	8024648027115	1	Pedal for SHERPA	148x60xh 25 cm	58"x23 5/8"xh 10"	7 Kg	15.4 lbs
218PE03A	8024648019257	1	Pedal for SA80	150x30xh 30 cm	59"x12"xh 12"	5 Kg	11.0 lbs
192SQ24A	8024648005656	1	Adjustable square 0/45°/90° for SA80, SA09, SHERPA	40x17xh 8 cm	16"x6 3/4"xh 3 1/8"	1,5 Kg	3.3 lbs
156CP01A	8024648054272	1	Extension side tables for SA80	40x40xh 15 cm	15 3/4"x15 3/4"xh 6"	4,1 Kg	9.0 lbs
218DJ	8024648009777	1	Jolly device for SA09	71x23xh 11 cm	28"x9"xh 4"	4,4 Kg	9.7 lbs
154SE17CP	8024648066480	1	Handles for SA09	40x28xh 18 cm	15 3/4"x11"xh 7"	6 Kg	13 lbs
411SE01A	8024648065254	1	Laser without stirrup	-	-	-	-
411SE A2	8024648070913	1	Laser with stirrup for Pikus Adv and SA25	-	-	-	-
411SE A1	8024648070906	1	Laser with stirrup for ZOE Adv	-	-	-	-
411SE A4	8024648070937	1	Laser with stirrup for SMS and SA80	-	-	-	-
411SE A3	8024648070920	1	Laser with stirrup for Sherpa	-	-	-	-
411SE A7	8024648070968	1	Laser with stirrup for CM manual	-	-	-	-
411SE A8	8024648070975	1	Laser with stirrup for SA09	-	-	-	-

Part No.	EXPLOIT		PIKUS 75	PIKUS ADV			SMS			MAXICUT	ZOE ADV				CM		SA25	SA80	SA09	SHERPA
	50	70		85	105	130	100	125	150		85	105	130	150	100	150				
218PE02A	-	-	-	-	-	-	-	-	-	-	-	-	-	-	-	-	-	-	-	•
218PE03A	-	-	-	-	-	-	-	-	-	-	-	-	-	-	-	-	-	-	-	•
192SQ24A	-	-	-	-	-	-	-	-	-	-	-	-	-	-	-	-	-	-	-	•
156CP01A	-	-	-	-	-	-	-	-	-	-	-	-	-	-	-	-	-	-	-	•
218DJ	-	-	-	-	-	-	-	-	-	-	-	-	-	-	-	-	-	-	-	•
154SE17CP	-	-	-	-	-	-	-	-	-	-	-	-	-	-	-	-	-	-	-	•
411SE01A	-	-	-	•	•	•	•	•	•	•	•	•	•	•	•	•	•	•	•	•
411SE A2	-	-	-	•	•	•	-	-	-	-	-	-	-	-	-	-	-	-	-	-
411SE A1	-	-	-	-	-	-	-	-	-	-	-	-	-	-	-	-	-	-	-	-
411SE A4	-	-	-	-	-	-	-	-	-	-	-	-	-	-	-	-	-	-	-	•
411SE A3	-	-	-	-	-	-	-	-	-	-	-	-	-	-	-	-	-	-	-	•
411SE A7	-	-	-	-	-	-	-	-	-	-	-	-	-	-	-	-	-	-	-	•
411SE A8	-	-	-	-	-	-	-	-	-	-	-	-	-	-	-	-	-	-	-	•

