



**HAWK**  
ENTERPRISES

# HAWK Red Tail 2014

## Surface Prep Orbital Floor Machine

Surface Preparation, Scrubbing, Refinishing

Operation • Care • Service



ELKHART, IN



HAWK ENTERPRISES

2902 Park Six Court, Elkhart, IN 46514

(574) 294-1910

(888) 289-4295

[www.hawken enterprises.com](http://www.hawken enterprises.com)

Service Information .....	2
Machine Specifications .....	3
Features .....	3
Important Safety Instructions.....	4
Grounding Instructions .....	5-6
Operations .....	7
Guidelines For Operations .....	7
Controls.....	7
Adjustments.....	8
Cord Storage .....	8
Clean Up And Storage .....	8
Limited Warranty .....	Back Cover

## SERVICE INFORMATION

To obtain consistent performance over the life of your equipment, read through these instructions and save them for future reference. If you require service, contact the dealer from which the machine was purchased or an authorized service station.

Always refer to your limited Warranty for complete service information.

The model, type, and serial number are indicated on the data plate on the side of the handle. From prompt and complete service, refer to these numbers when inquiring about service.

SERIAL NO.		MODEL
VOLTS	PHASE	HZ
MOTOR	AMPS	H.P.

Write the model and serial number of your unit in the space provided. Refer to the data plate on unit.	
SERIAL #	MODEL #
Retain this owners manual for future reference.	

Model #	REDTAIL2014
Part #	F-REDTAIL-2014
Pad Size	20" X 14"
Pad Driver Type	Combination Pad Holder/Diamond Pad Driver
Power Source	115V 60Hz
Motor/HP	1.0 HP TEFC 1740 Rpm
Amp Draw	7.8
Vibration Compensator	1.25 Inches
Cord	50' 14-3 SJT
Pad Pressure (lbs/in <sup>2</sup> )***	.40
Total Weight **	162
Shipping Weight	198
<b>**Weight is calculated without the power cord</b> <b>***Pad pressure does not include the weight of the power cord.</b> <i>Specifications subject to change without notice.</i>	

<p><b>Features</b></p> <ul style="list-style-type: none"> <li>• Twin (dual) capacitor 56-frame TEFC (totally enclosed fan cooled) motor keeps out dirt and dust for longer motor life.</li> <li>• Extra heavy duty spring steel cord strain relief with a 50' 14-3 power cord</li> <li>• Low current draw</li> <li>• Thumb-operated safety switch</li> <li>• Negative pressure on/off switch</li> <li>• Dual steel operating triggers for left- or right-hand operation</li> </ul>	<ul style="list-style-type: none"> <li>• One-piece industrial powder coated heavy duty steel handle for optimum durability</li> <li>• Welded frame for rugged, reliable performance</li> <li>• Non-marking, 2x6" ball bearing wheels</li> <li>• Multiple position handle adjustment for operator comfort and safety</li> <li>• Comfortable vinyl handle grips for ease of use</li> <li>• Full wraparound dust skirt</li> </ul>
--	--

# IMPORTANT SAFETY INSTRUCTIONS

When using an electrical appliance, basic precautions should always be followed, including the following:



## WARNING:

ELECTRIC SHOCK CAN CAUSE SERIOUS INJURY OR BE FATAL. PLEASE READ THE FOLLOWING INSTRUCTIONS ON THE USE AND OPERATIONS OF FLOOR FINISHING MACHINES.

- Your TigerHawk is equipped with a safety switch lock and power switch triggers designed for your safety. Do not attempt to bypass or defeat the safety switch lock. Never use any device to lock the power switch triggers in the “ON” position.
- Do not leave the TigerHawk plugged in. Turn off the switch and unplug the electrical cord when not in use and before servicing or changing the brushes or pads.
- Do not allow the machine to be used as a toy. Close attention is necessary when used near children. Do not leave the machine connected to an electrical outlet unattended.
- Use only as described in this manual. Use only manufacturer’s recommended attachments.
- Do not use with a damaged cord or plug. If the machine is not working as it should, has been dropped, damaged, or left outdoors, return it to a service center before using.
- Use care to keep the electrical supply cord around sharp edges or corners. Keep the cord away from the heated surfaces.
- Connect to properly grounded (3-wire) outlet only. Refer to Grounding Instructions, Page 5-6.
- Do not use extension cords or outlets with inadequate current carrying capacity.
- Turn off all controls before unplugging.
- Do not unplug by pulling on the cord. To unplug, grasp the plug and pull.
- Do not handle the plug or TigerHawk with wet hands.
- Wind the cord no tighter than is necessary to retain it during storage. Refer to Cord Storage, Page 8.
- Use extra care when working on or near stairs.
- Do not use in conjunction with flammable or combustible liquids such as gasoline, or use in areas where explosive vapor or dust may be present.
- Store your TigerHawk indoors in a cool, dry area.
- Keep your work area well lighted.
- **WARNING:** To avoid electrical shock, use indoor only.



## **WARNING:**

**RISK OF EXPLOSION. FLOOR SANDING MACHINE CAN RESULT IN AN EXPLOSIVE MIXTURE OF FINE DUST AND AIR. USE FLOOR SANDING MACHINE ONLY IN A WELL-VENTILATED AREA, FREE FROM ANY FLAME OR MATCH**

### **GROUNDING INSTRUCTIONS**

This appliance must be grounded. If it should malfunction or break down, grounding provides a path of least resistance for electric current to reduce the risk of electric shock. This appliance is equipped with a cord that has an equipment-grounding conductor and grounding plug. The plug must be plugged into an appropriate outlet that is properly installed and grounded in accordance with all local codes and ordinances.

### **FOR FLOOR FINISHING MACHINES RATED LESS THAN 150 VOLTS**

Improper connection of an equipment grounding conductor can result in risk of electric shock. Check with a qualified electrician or service person if you are in doubt as to whether the outlet is properly grounded. Do not modify the plug provided with the appliance. If it will not fit the outlet, have a proper outlet installed by a qualified electrician. This appliance is for use on a nominal 120 volt circuit and has a grounding plug that looks like the plug illustrated in Figure 1.

A temporary adapter which looks like the adapter illustrated in Figure 2 may be used to connect this plug to a two pole receptacle, as shown, if a properly grounded outlet is not available. The temporary adapter should be used only until a properly grounded outlet (Figure 1) can be installed by a qualified electrician. The green colored rigid ear, lug, or the like extending from the adapter must be connected to a permanent ground such as a properly grounded outlet box cover. Whenever the adapter is used, it must be held in place by metal screw.

### **FOR FLOOR FINISHING MACHINES RATED 150-220 VOLTS:**

If the machine is provided with an attachment plug cap as shown in Figure 3, it is intended for use on a 240 volt (nominal) circuit. No adapter is available for this cap.



**WARNING:**  
DO NOT USE GROUNDING  
ADAPTERS ON TIGERHAWKS IN  
CANADA. CHECK WITH CANADIAN CODE  
FOR PROPER EQUIPMENT USAGE.  
IMPROPER USE OF GROUND ADAPTORS CAN  
CAUSE SERIOUS INJURY, FIRE, OR BE FATAL.

## Grounding Instructions (Continued)

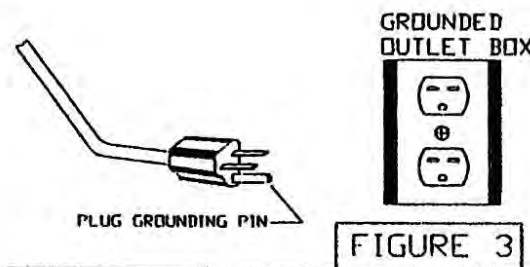
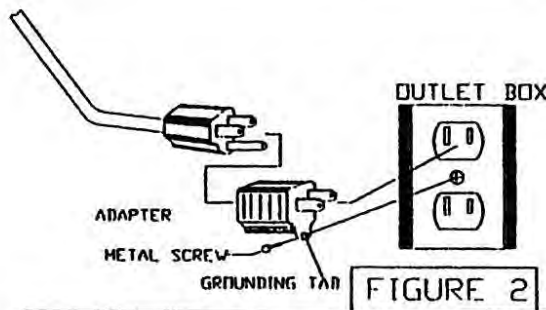
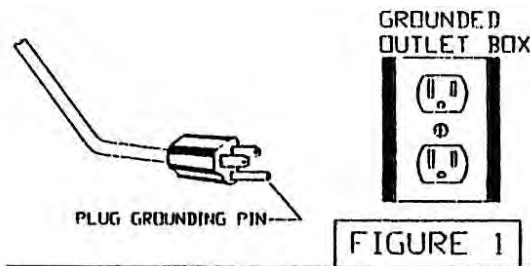

# CONTROLS

## TO TURN THE MACHINE ON

The operating handle must be lowered and locked to the proper operating position before switching the machine ON. Place both hands firmly on the handle grips with your fingers around the power triggers. **Do NOT** apply pressure on the triggers before the safety switch lock is disengaged.

Disengage the safety switch lock by pushing it forward with one thumb. Then, while holding the safety switch lock in the disengaged position, squeeze the power triggers toward the handle grips and return your thumb to the handle grip.

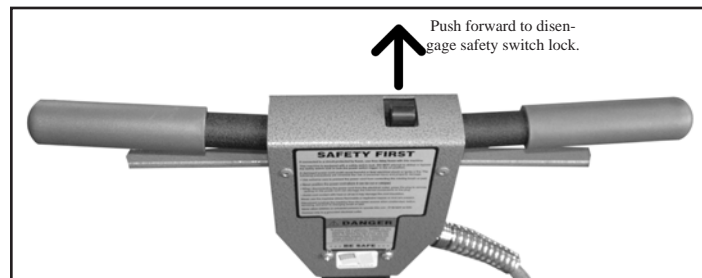

To stop the machine, simply release the triggers. The safety switch lock will automatically return to the engaged position.

## GUIDELINES FOR OPERATION

- Your RedTail is a very sensitive, powerful unit. When in operation, it should be guided gradually and smoothly without sudden or rough motions. You will want to practice with your machine on a smooth surface until you have experience in operating it.
- For ease of operation, always keep the brush or pad surface level, balanced, and flat on the floor at all times.
- Always adjust the operating handle to a comfortable height at which the brush or pad surface is balanced before starting the machine. (See Handle Adjustment Page 4)
- Your RedTail will operate differently on various surfaces. For example, there will be much more resistance when the machine is used on a rough surface, than when it is used on a smooth surface. The operator should be prepared to adjust for these differences.
- BEGIN OPERATING THE REDTAIL
- 
- WITH THE PAD SURFACE LEVEL, BALANCED AND FLAT ON THE FLOOR.
- To move the machine to the right, turn the unit to the right.
- To move the machine to the left, turn the unit to the left.
- To move the machine forward or backward, keep the brush or pad flat on the floor and push or pull the machine in the desired direction.

## ADJUSTMENTS HANDLE ADJUSTMENT

The handle can be adjusted to any desired work position by simply pulling on the pull pin and move the handle to the desired position. Firmly push the pull pin back into the adjustment holes. This will lock the handle in position.

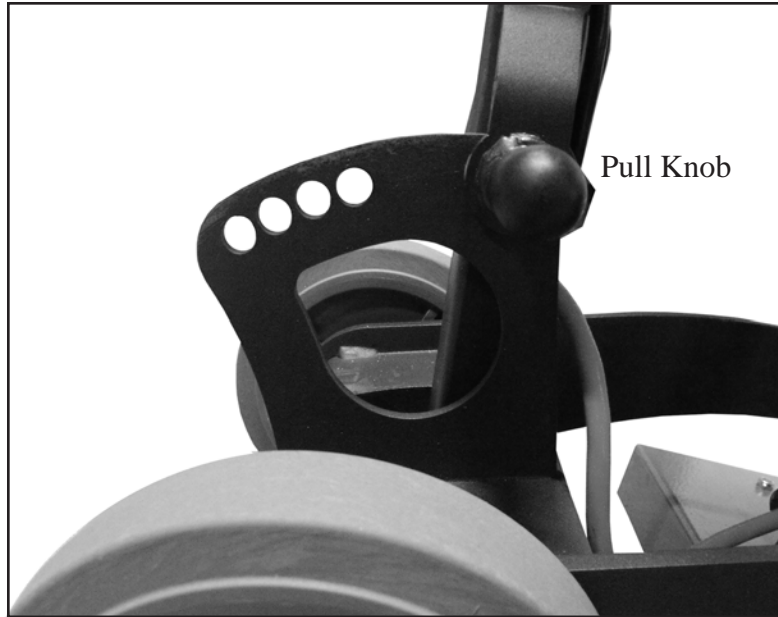

Figure 5

## CORD STORAGE

When not in use, loosely coil the power cord and hang on the handle.



## CLEANUP AND STORAGE

After being used, your TigerHawk can be wiped clean with a soft damp cloth and should be stored in a clean, dry place.



*R E D T A I L*

*B Y*

*H A W K*

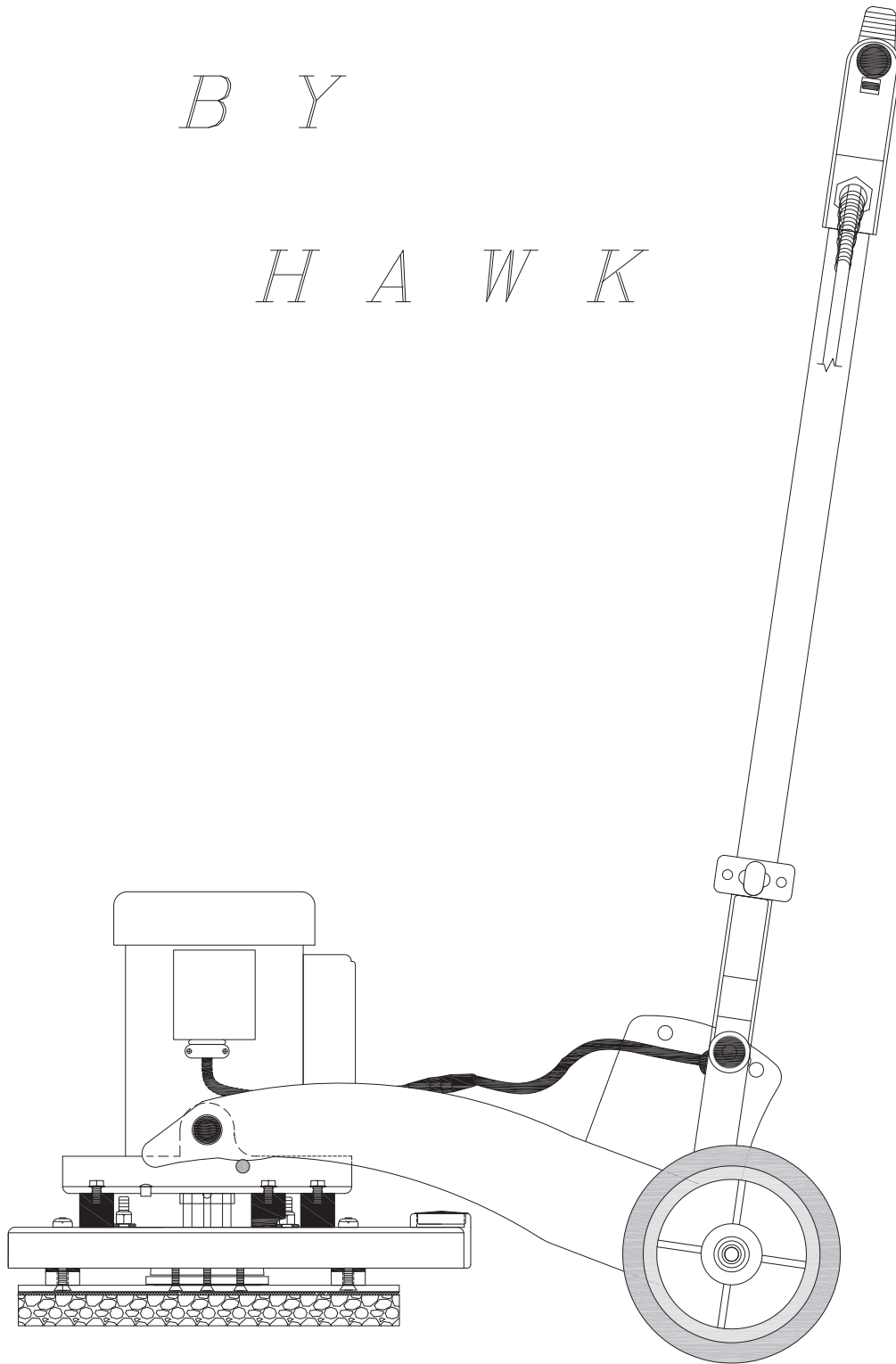

FRONT  
VIEW

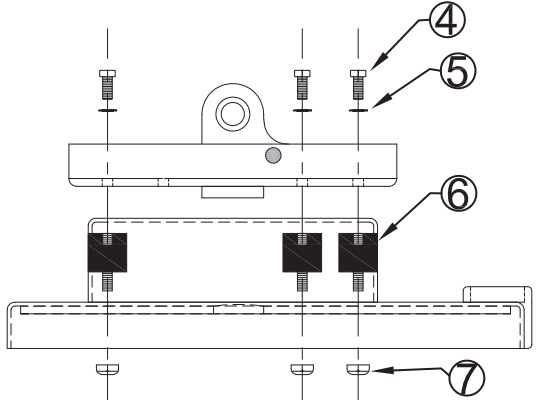
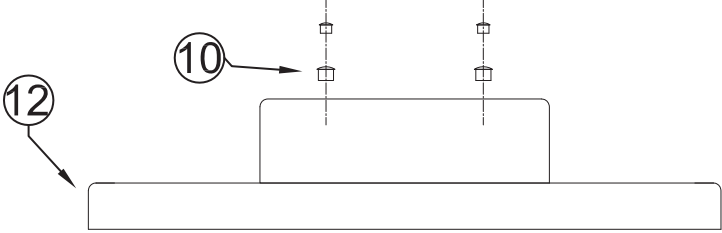

SIDE VIEW  
FRONT

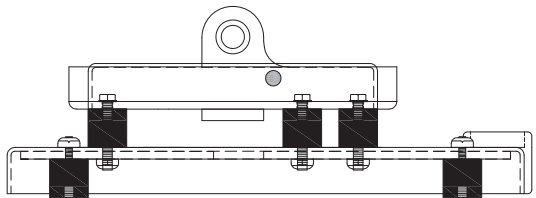

SIDE VIEW  
FRONT

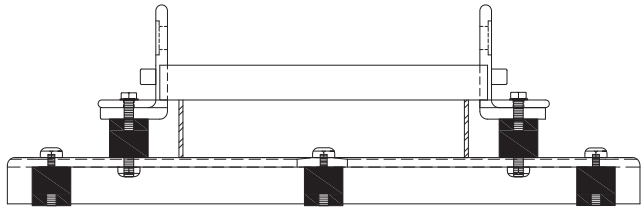
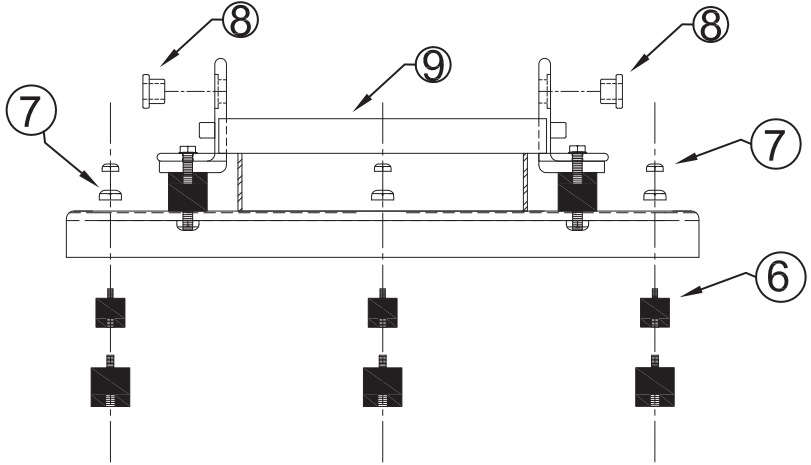
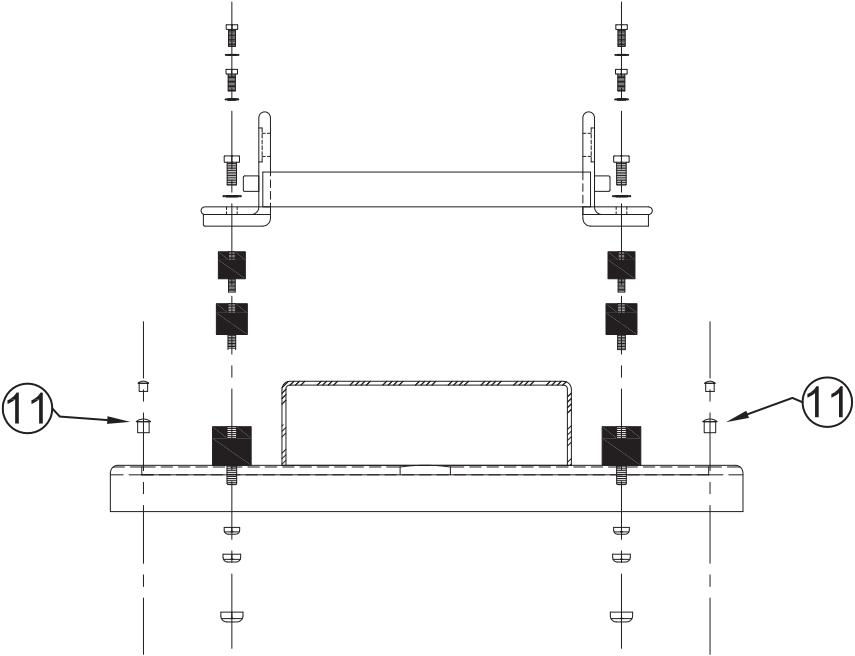

FRONT VIEW

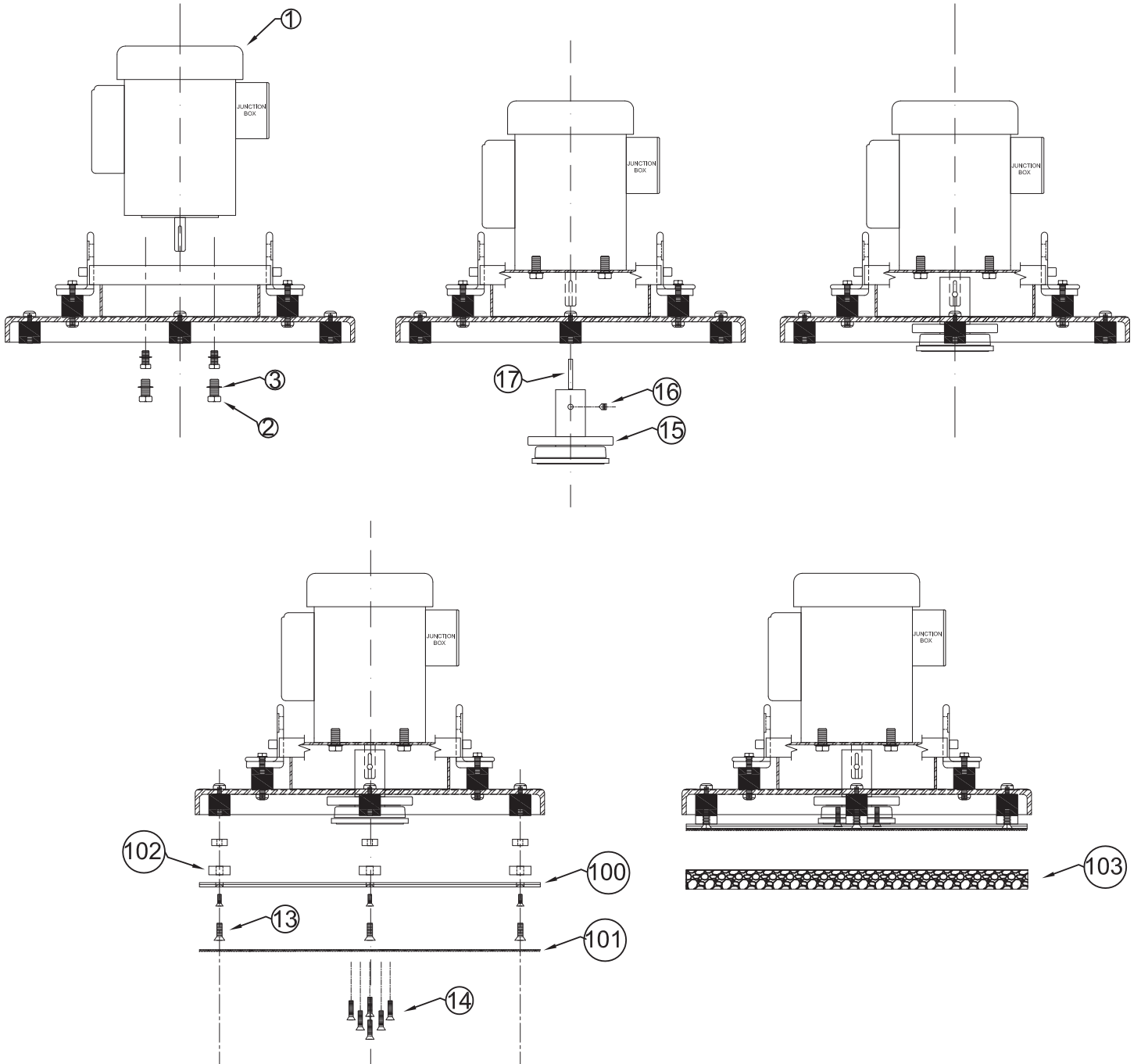

SEE FIGURE (3)

# INSTALLATION SEQUENCE OF WHEELS AND HANDLE ASSEMBLY

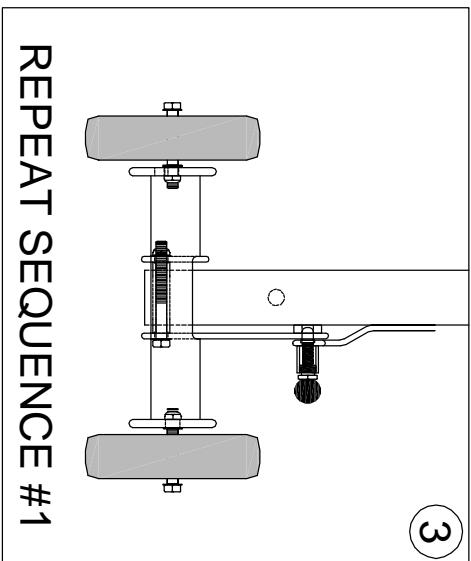
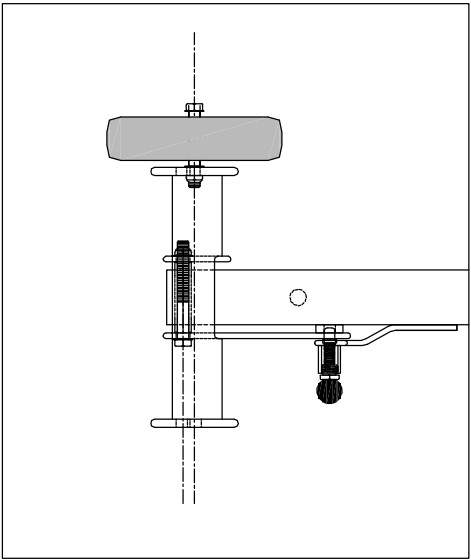
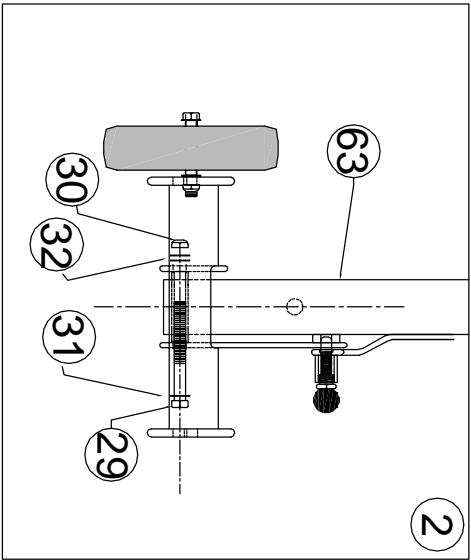
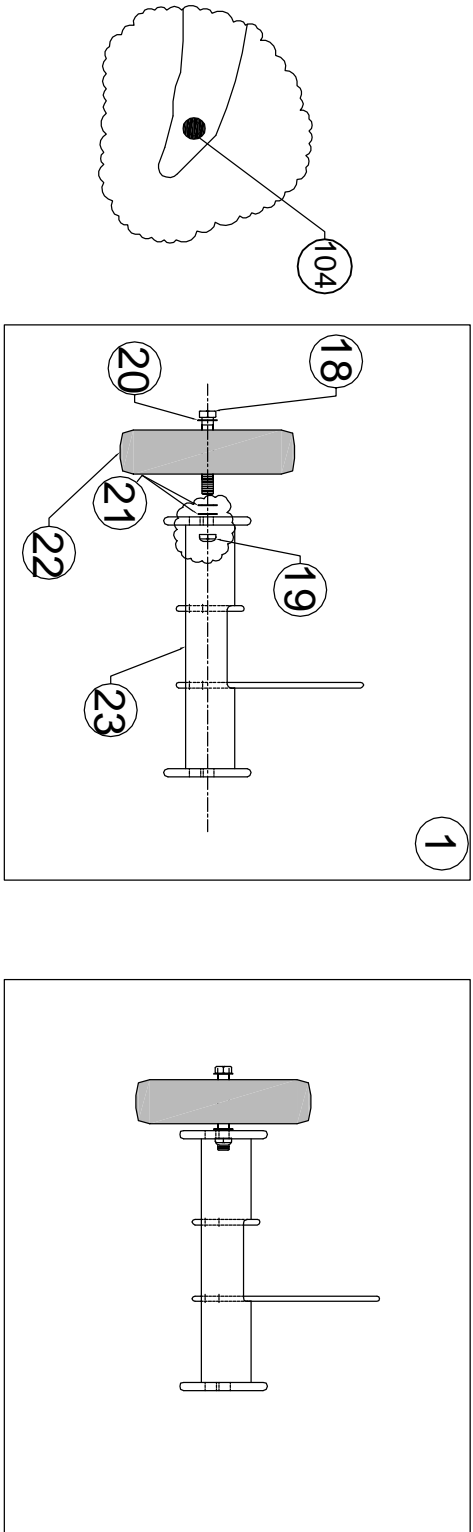

FIGURE (2)  
REAR VIEW

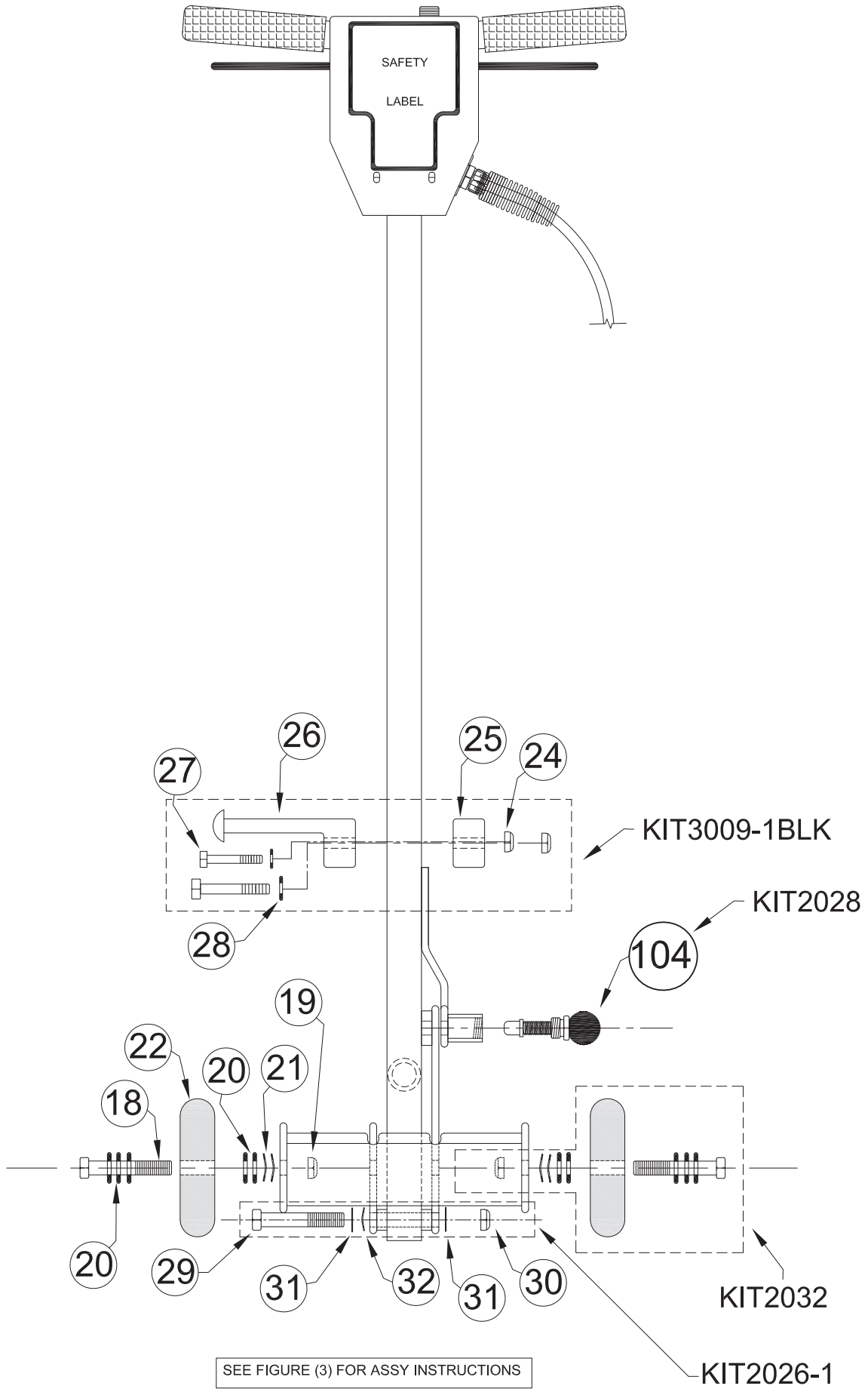
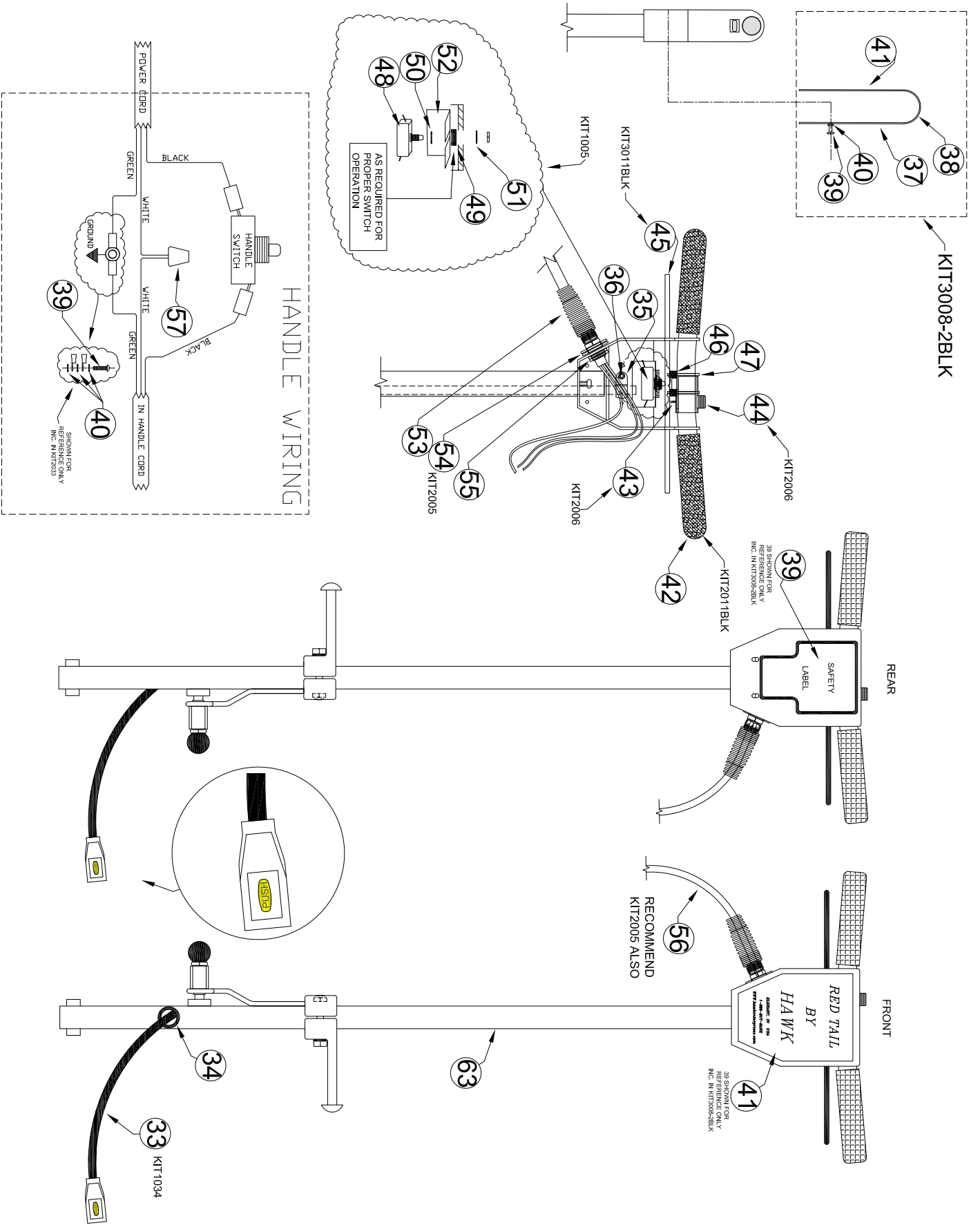

FIGURE (4)



**RED TAIL MAIN ASSY**

DETAIL NUMBER	PART NUMBER	DESCRIPTION	QTY REQ'D
	<b>KIT1042</b>	<b>MOTOR KIT - RED TAIL</b>	1
1	INC IN KIT1042	MOTOR	1
2	INC IN KIT1042	BOLT	4
3	INC IN KIT1042	LOCWASHER	4
	<b>KIT2037</b>	<b>SECONDARY ISOLATOR KIT - RED TAIL</b>	1
4	INC IN KIT2037	BOLT	6
5	INC IN KIT2037	LOCKWASHER	6
6	INC IN KIT2037	ISSOLATOR	6
7	INC IN KIT2037	NUT	6
	<b>KIT2036</b>	<b>SECONDARY ISOLATOR BRACKET KIT - RED TAIL</b>	1
8	INC IN KIT2036	PIVOT BUSHING KIT (KIT2023)	1
9	INC IN KIT2036	SECONDARY ISSOLATOR BRACKET - RED TAIL	1
	<b>KIT2023</b>	<b>PIVOT BUSHING KIT</b>	1
8	INC IN KIT2023	BUSHINGS PIVOT NYLON	2
	<b>KIT2040</b>	<b>BUTTON PLUG KIT - RED TAIL</b>	1
10	INC IN KIT2040	BUTTON PLUG 1/2 INCH	4
11	INC IN KIT2040	BUTTON PLUG	4
	<b>KIT3034RED</b>	<b>FRAME KIT MAIN - RED TAIL</b>	1
10	INC IN KIT3034	BUTTON PLUG KIT 1/2 INCH	1
11	INC IN KIT3034	BUTTON PLUG KIT	1
12	INC IN KIT3034	MAIN FRAME - RED TAIL	1
	<b>KIT2039</b>	<b>PRIMARY ISOLATOR KIT - RED TAIL</b>	1
7	INC IN KIT2039	NUT	6
6	INC IN KIT2039	ISSOLATOR	6
13	INC IN KIT2039	SCREW	6
14	INC IN KIT2039	ECCENTRIC SCREW	6
	<b>KIT2041</b>	<b>ECCENTRIC KIT - RED TAIL</b>	1
15	INC IN KIT2041	ECCENTRIC - RED TAIL	1
16	INC IN KIT2041	SET SCREW	1
14	INC IN KIT2041	ECCENTRIC PAD DRIVER SCREWS	6
13	INC IN KIT2041	PAD DRIVER SCREWS	6
17	INC IN KIT2041	MOTOR KEY	1
	<b>KIT2038</b>	<b>PAD DRIVER KIT - RED TAIL</b>	1
100	INC IN KIT2038	PAD DRIVER - RED TAIL	1
101	INC IN KIT2038	PAD DRIVER FACE - RED TAIL	1
102	INC IN KIT2038	NYLON SPACER	6
13	INC IN KIT2038	SCREWS PAD DRIVER - RED TAIL	6
14	INC IN KIT2038	ECCENTRIC PAD DRIVER SCREWS	6
103	<b>KIT2047</b>	<b>BACKER PAD - RED</b>	1
	INC IN KIT2047	RED PAD 2014X1	1
	INC IN KIT2047	VELCRO	2
	<b>KIT2028</b>	<b>SPRING KNOB ASSY.</b>	3
104	INC IN KIT2028	KNOB ASSY.	1
	<b>KIT2032</b>	<b>WHEEL KIT</b>	2
18	INC IN KIT2032	BOLT HEX .500-13 X 3	1
19	INC IN KIT2032	NUT HEX .500-13 NYLOC	1
20	INC IN KIT2032	FLAT WASHER	5
21	INC IN KIT2032	WASHER SPRING WAVE	2
22	INC IN KIT2032	WHEEL	1
	<b>KIT3031</b>	<b>CARRAGE FRAME</b>	1
23	INC IN KIT3031	CARRAGE FRAME (ONLY)	1

**RED TAIL HANDLE ASSY**

	<b>KIT3009-1BLK</b>	<b>CORD HOOK KIT (SQUARE)</b>	1
24	INC IN KIT3009-1BLK	NUT 3/8-16 NYLOCK	2
25	INC IN KIT3009-1BLK	CAP CORD HOOK SQUARE BLK	1
26	INC IN KIT3009-1BLK	CORD HOOK SQUARE BLK	1
27	INC IN KIT3009-1BLK	BOLT HEX 3/8-16 X 2	2
28	INC IN KIT3009-1BLK	WASHER FLAT BLK	2
	<b>KIT2026-1</b>	<b>HANDLE MOUNTING HWDR KIT</b>	1
29	INC IN KIT2026-1	BOLT HEX .500-13 X 3	1
30	INC IN KIT2026-1	NUT HEX .500-13 NYLOC	1
31	INC IN KIT2026-1	FLAT WASHER	2
32	INC IN KIT2026-1	WASHER SPRING WAVE	2
	<b>KIT1034</b>	<b>IN HANDLE CORD KIT</b>	1
33	INC IN KIT1034	IN HANDLE CORD	1
34	INC IN KIT1034	GROMMET IN HANDLE	1
35	INC IN KIT1034	LOOP CLAMP	1
36	INC IN KIT1034	SCREW 10-24 X .50 THIRD ROLL PHILL PAN ZINC	1
40	INC IN KIT1034	WASHER # 10 EXTERNAL TOOTH LOCK - ZINC	4
57	INC IN KIT1034	WIRE NUT	1
39	INC IN KIT1034	SCREW 10-24 X .50 THIRD ROLL PHILL PAN ZINC	3
	INC IN KIT1034	BUTTON PLUG (NOT SHOWN)	1
	<b>KIT3008-2BLK</b>	<b>SWITCH BOX ASSY KIT</b>	1
37	INC IN KIT3008-2BLK	WARNING SWITCH BOX SAFETY LABEL REAR	1
38	INC IN KIT3008-2BLK	SWITCH BOX COVER	1
39	INC IN KIT3008-2BLK	SCREW 10-24 X .50 THIRD ROLL PHILL PAN ZINC	2
40	INC IN KIT3008-2BLK	WASHER # 10 EXTERNAL TOOTH LOCK - ZINC	2
41	INC IN KIT3008-2BLK	SWITCH BOX COVER LABEL FRONT	1
	<b>KIT2011BLK</b>	<b>HABDLE GRIP KIT - BLK</b>	1
42	INC IN KIT2011BLK	HANDLE GRIP -BLK	2
	<b>KIT2006</b>	<b>SAFETY SWITCH KIT</b>	1
43	INC IN KIT2006	SPRING 2LNG X .025 OD X .026	1
44	INC IN KIT2006	SAFETY SWITCH	1
	<b>KIT3011BLK</b>	<b>TRIGGER REPLACEMENT KIT</b>	1
45	INC IN KIT3011BLK	TRIGGER - BLK	1
46	INC IN KIT3011BLK	SPRING - TRIGGER	2
47	INC IN KIT3011BLK	ROLL PIN	2
	<b>KIT1005</b>	<b>REPLACEMENT SWITCH KIT - MAIN</b>	1
48	INC IN KIT1005	SWITCH	1
49	INC IN KIT1005	WASHER FLAT- ZINC	5
50	INC IN KIT1005	WASHER FLAT 5/16 USS - ZINC	1
51	INC IN KIT1005	WASHER 3/8 INTRNL TOOTH LOC-ZINC	1
52	INC IN KIT1005	SWITCH INSULATION	1
	<b>KIT3032</b>	<b>HANDLE ASSY LESS POWER CORD &amp; SWITCH BOX COVER</b>	1
63	INC IN KIT3032	HANDLE WDMT - BLK	1
	INC IN KIT3032	KIT2005 STRAIN RELIEF REPLACEMENT KIT	1
	INC IN KIT3032	KIT2033 HANDLE HARDWARE KIT	1
	INC IN KIT3032	KIT3011BLK TRIGGER REPLACEMENT KIT	1
	INC IN KIT3032	KIT2006 SAFETY SWITCH KIT	1
	INC IN KIT3032	KIT3009-1BLK CORD HOOK KIT (SQUARE)	1
	INC IN KIT3032	KIT1005 REPLACEMENT SWITCH KIT - MAIN	1
	INC IN KIT3032	KIT2026-1 HANDLE MOUNTING HWDR KIT	1
	INC IN KIT3032	KIT1043 IN-HANDLE CORD KIT	1
	<b>KIT2005</b>	<b>STRAIN RELIEF REPLACEMENT KIT</b>	
53	INC IN KIT2005	STRAIN RELIEF	1
54	INC IN KIT2005	WASHER STRAIN RELIEF - ZINC	2
55	INC IN KIT2005	NUT CONDUIT 1/2	1
56	E0003-2	POWER CORD 14-3 SJT BLK THIN 50 FT CORD	1
	<b>KIT2033</b>	<b>HANDLE HARDWARE KIT</b>	1
57	INC IN KIT2033	WIRE NUT	1
39	INC IN KIT2033	SCREW 10-24 X .50 THIRD ROLL PHILL PAN ZINC	4
40	INC IN KIT2033	WASHER # 10 EXTERNAL TOOTH LOCK - ZINC	5
35	INC IN KIT2033	LOOP CLAMP	1
34	INC IN KIT2033	GROMMET IN HANDLE	1



## LIMITED WARRANTY

Your HAWK equipment which has been manufactured, tested and inspected in accordance with carefully specified engineering requirements, is warranted to be free from defects in material and workmanship. This Limited Warranty is, however, subject to the Following qualifications, conditions and limitations which are set forth to provide you and all users of the HAWK equipment with information concerning the duration, extent, availability, and applicability of this HAWK Limited Warranty, the procedure to be taken to obtain its performance, and other information concerning the **HAWK Limited Warranty policy**.

The HAWK ENTERPRISES Limited Warranty is extended to the original end user as follows:

Motors 1 year parts and 6 months labor

Non-wear items: 1 year parts replacement and 1 year service labor warranty.

Replacement parts guaranteed for 90 days from date of installation against defects in material and workmanship.

This Limited Warranty will not cover damage attributable to the following:

- (1) Improper, unreasonable or negligent use or abuse of the equipment
- (2) Abrasions or punctures of the equipment.

The start date of the Limited Warranty coverage shall be the purchase date of the original end user or six months from the date the machine was shipped from the Factory, whichever comes first.

### PARTS OF EQUIPMENT NOT COVERED BY THE LIMITED WARRANTY

Certain parts of equipment require replacement in the ordinary use due to normal wear by reason of their characteristics. Normal wear items such as cords, switches, bumpers, bearings, isolators, compensators, capacitors etc. are excluded from the Limited Warranty.

### EXCEPTIONS AND EXCLUSIONS FROM THE LIMITED WARRANTY

This equipment is required to be used on electric current as indicated on the data plate. Otherwise damage, defects, malfunctions or other failure of the equipment arising from use on electric current not as indicated are excepted and excluded from this Limited Warranty. Defects, malfunctions, failure or damage of the equipment caused by improper, unreasonable or neglect use or abuse while in possession of the purchaser are likewise excluded from this warranty. If repair is done on your equipment by anyone other than those designated as authorized to perform such work without first having obtained factory instructions, HAWK ENTERPRISES at its sole option, may determine that this warranty will not apply and that reimbursement for such repair will not be made because of the failure to comply with such factory specified instructions.

### PROCEDURE TO BE TAKEN TO OBTAIN PERFORMANCE OF LIMITED WARRANTY REPAIR

To secure repair of the equipment or any warranted parts under this Limited Warranty, the following procedure should be taken. The inoperative equipment or warranted parts, together with satisfactory evidence of the purchase date, must be delivered, with shipping and delivery charges prepaid, to one of the following:

- (1) The dealer from whom purchased;
- (2) Any HAWK distributor's service department in the United States;
- (3) Any HAWK authorized service station in the United States.

If you are unable to locate any of the foregoing, you may write or otherwise communicate with HAWK ENTERPRISES before repair service is performed by anyone else. In such event, HAWK ENTERPRISES will provide either the location or a closely available HAWK distributor service department, or HAWK authorized service station or other factory instructions. Upon compliance with the above procedure, all warranted defects will be repaired, at no additional charge or costs to the customer, and the repaired product returned to the customer, with all shipping and delivery charges pre-paid. In following the procedures set forth, PLEASE MAKE CERTAIN to state the model, type and serial number as shown on the data plate of the equipment.

### REPLACEMENT

In the event of a defect, malfunction or failure of your HAWK equipment or any warranted part to conform with this warranty, HAWK may, at its sole option and own expense, replace the equipment or any warranted part with another new, identical or reasonably equivalent model or part in lieu or repairing the defect. **DO NOT** return any equipment or part to the factory without prior authorization.

### NO REFUND OF PURCHASE PRICE

HAWK ENTERPRISES **WILL NOT**, as a matter of its Limited Warranty policy, refund the customer's purchase price.

### LIMITED WARRANTY REGISTRATION CARD FOR YOUR EQUIPMENT AND REQUEST FOR INFORMATION

Your HAWK distributor from whom you purchased your equipment is responsible for the registration of your Limited Warranty with the factory. Any information or questions you may have concerning your HAWK ENTERPRISES equipment or this Limited Warranty may likewise be secured from the factory. This Limited Warranty will give you specific legal rights, and you may also have other rights which vary from state to state.