

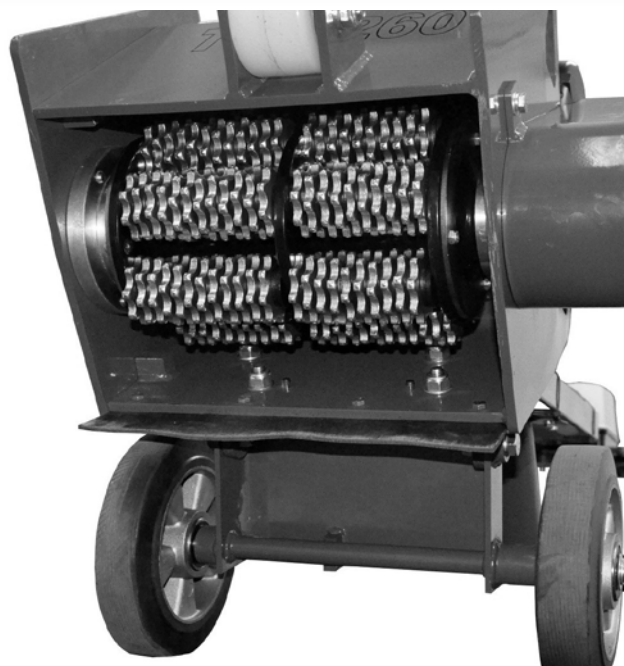

## TFP260 FLOOR PLANER



## OPERATION & MAINTENANCE



# OPERATION

## Foreword

Thank you for your purchase of the TRELAWNY TFP260 Floor Planer.

This manual contains the necessary maintenance information for you to ensure proper operation and care for this machine.

**See also the manual that is supplied by the engine manufacturer.**

**It is essential for you to read through these manuals thoroughly.**

In the unlikely event that you experience problems with your TFP260, please do not hesitate to contact your local Trelawny dealer or agent. We always welcome feedback and comments from our valued customers.

## General Information

Before operating, performing maintenance or repairing the TFP260 FLOOR PLANER this manual must be read and understood by the operator, if in any doubt, ask your supervisor before using this equipment.

Local safety regulations must be followed at all times. Failure to follow these instructions could result in damage to the TFP260 and/or personal injury.

Trelawny SPT Limited disclaims all responsibility for damage to persons or objects arising as a consequence of incorrect handling of the machine, failure to inspect the machine for damage or other faults that may influence the operation prior to starting work, or failure to follow the safety regulations listed or applicable to the job site.

This machine is primarily designed for the removal of paint, heavy rust, scale and for the removal of laitance from concrete from floor areas. It can be used both indoors and out. Electric models are more suitable for indoor use because of the toxic gases that are produced by petrol engines. This machine must not be used in a fixture.

## Safety

WEAR SAFETY BOOTS, FACE MASK, SHATTERPROOF GLASSES, HELMET, GLOVES and any other personal protective equipment required for the working conditions. Avoid loose clothing; this may become trapped in moving parts and cause serious injury.

TO AVOID NUISANCE DUST, connect an industrial vacuum cleaner (minimum 3000watts or equivalent) to the 50mm (2") vacuum port situated at the rear of the machine.

ENSURE THAT THE WORK PLACE IS WELL VENTILATED. Avoid operating engine-powered machines in an enclosed area, since engine exhaust gases are poisonous.

BE VERY CAREFUL WITH HOT COMPONENTS. Exhausts and other parts of the engine are hot during operation and can remain hot for some time after shutdown.

**DO NOT REFUEL THE ENGINE WHILE THE ENGINE IS HOT OR RUNNING**, there is a very real danger from explosion – always refuel when the engine is cold, and in the open air.

During transportation fasten fuel cap tightly and close fuel cock.

**DO NOT OPERATE ELECTRIC VERSIONS IN WET CONDITIONS.**

CAUTION THIS MACHINE IS HEAVY. It weighs around (Wt 122 kg (269 lbs)) dependent on power unit. Do not lift this machine manually.

### IMPORTANT:

When fitted with the petrol engine, AVOID TIPPING THE TFP260 BACKWARDS, especially when hot; the engine oil can run past the piston and into the combustion chamber causing the piston to "hydraulic lock" when next attempting to start the engine.

Never attempt to forcibly turn the engine over if this has taken place, severe damage to the engine can be caused, resulting in a costly major strip down and possible injury to the operator.

To remove the oil from the cylinder, first remove the spark plug and place a lint free cloth over the plughole to capture the jettisoned oil. Turn the engine over with the ignition switch and fuel cock in the off position and expel as much of the oil as possible. Clean the spark plug to remove oil from the electrodes and replace. The plug may have to be removed and cleaned several times before the engine will start. Upon starting, the engine may produce smoke for a while from the exhaust, but this should soon clear.

Finally stop the engine and recheck the engine oil level. (Ensure that the engine is level prior to carrying out this check). If the engine oil level is low, refill with the recommended motor oil - see engine manufacturers operating instructions.

## Risk of Hand-arm Vibration injury

These tools may cause Hand-arm Vibration Syndrome injury if their use is not adequately managed.

We advise you to carry out a risk assessment and to implement measures such as; limiting exposure time [i.e. actual trigger time, not total time at work], job rotation, ensuring the tools are used correctly, ensuring the tools are maintained according to our recommendations, and ensuring that the operators wear personal protective equipment [PPE] particularly gloves and clothing to keep them warm and dry.

Employers should consider setting up a programme of health surveillance to establish a benchmark for each operator and to detect early symptoms of vibration injury.

We are not aware of any PPE that provides protection against vibration injury by attenuating vibration emissions.

**See 'Specifications' section for vibration emission data.**

Further advice is available from our Technical Department.

We strongly advise you to visit the Health & Safety Executive website <http://www.hse.gov.uk/vibration> This site provides excellent advice and information on HAV and currently, includes a Hand-arm Vibration Exposure Calculator that is easy to use to work out the daily vibration exposure for each of your operators.

## Cutter types & Applications

### T.C.T

Hardened steel cutter with tungsten carbide inserts. For all general cleaning applications, including concrete texturing, Scabbling, the grooving of concrete, removal of embedded roof chippings, brittle coatings from steel work. Use TCT Cutters on heavy applications, for longer life and higher output. *Produces "tramlines" on concrete and small indentations on steelwork.*

### STAR

Heat-treated steel cutters used for the aggressive removal of Paint and coatings from floor areas, but with a shorter life span than Beam Cutters. Can be used for the general removal of dirt and ice deposits and to produce a texture on concrete surfaces. *Produces roughened surface on concrete and some marking on steelwork.*

### BEAM

Heat-treated steel cutters used for the removal of Paint and coatings from floor areas, but with a shorter life span than TCT Cutters, not as aggressive as Star Cutters. Can be used for the general removal of dirt and ice deposits. *Produces a fine texture on concrete surfaces and slight marking on steelwork.*

### MILLING

Flat tungsten carbide cutters for the removal of thermo-plastic road and runway markings. Very efficient and cost effective with none of the problems associated with burning off. These can also be used for the removal of bituminous and rubber deposits. Very effective for the removal of two part epoxy floor paint, may require finishing with beam cutters or the Trelawny floor grinder to achieve the required finish.

**Note:** Care must be taken with milling cutters to ensure that the Drum and its Cutters are fitted the correct way round, the tungsten carbide tips must face towards the vacuum port at the bottom as the drum rotates, otherwise the tips will be damaged in use. *Produces a "strip" on concrete and tarmac, is not recommended on steelwork unless used for "braking up" coatings.*

NB: Increasing or decreasing the number of spacers used can alter the performance and finish characteristics of each cutter type. Ensure that the same type and quantity of spacers and cutters are fitted to the opposite cutter shaft to maintain the drums balance. An out of balance drum can be very dangerous and will also **dramatically increase the vibration emissions.**

# OPERATION

## Pre-Start Check

Check all bolts and screws for tightness. Ensure that all fittings are secure.

Check the drive belt for correct tightness. There should normally be approximately 13mm (1/2") of free play when one side of the belt is depressed in the middle position between the two pulleys. To set the belt tension, refer to the *Belt Installation & Setting* section.

### For Petrol Engines

Check engine oil level. If the engine oil level is low, refill with the relevant motor oil recommended in the engine manufacturers operating and maintenance manual.

**IMPORTANT:** Do not lean the machine backwards onto its handle to inspect the cutters or drum. It is possible for engine oil to seep into the cylinder bore, especially if the engine is hot. If this has occurred,

### **DO NOT ATTEMPT TO START THE ENGINE,**

the oil can cause the piston to lock hydraulically, which may cause severe damage to the engine and injure the operator. With ignition turned off, very slowly pull the starter cord, if the engine cannot be turned over, the above may have taken place. Rectification will necessitate the spark plug being removed and the engine turned over by pulling the starter cord (with ignition turned off) to "eject" the oil. Use a lint free clean cloth over the plughole to capture the ejected oil. The spark plug will require removing and cleaning, possibly several times until the engine restarts.

### **415v Motors**

The TFP260 is supplied with a specially commissioned electric motor and starter switch assembly. Each unit is fully tested and the overload relays have been calibrated and set according to the manufactures specifications. In the event of malfunction on a new machine, the owner should first check that the power supply on site is suitable and adequate. All cables should be fully uncoiled and never left wrapped around cable reels or tied in loops. The starter box is fitted with a safety feature to protect the motor and relays from damage.

The starter boxes are preset and under no circumstances should they be tampered with, stripped down or adjusted, otherwise it will invalidate the warranty.

Take particular care when using 415v Machines; ensure that the electrical supply is earthed and that breakers and fuses are correct for the loading. The switches are preset and under no circumstances should they be tampered with, stripped down or adjusted, otherwise it will invalidate the warranty.

The 415v motor requires the minimum of a 10amp, 380v power supply

Always use the shortest possible length of extension cable. To avoid voltage drop the cable must have a minimum core wire size of 2.5mm<sup>2</sup> cross-section area.

Maximum length of cable 30 meters.

## Starting

### **Engine models:**

Check that there is sufficient fuel in the fuel tank. (See manufactures hand book for type) Check that the engine oil level is correct. (See pre-start check). Ensure that the machine cutting depth adjustment hand wheel (55) is in the fully raised position. (Cut engagement lever (58) must be in the down/forward position to make any adjustment) Depress the hand wheel (55) to disengage the locking pin and rotate anti clockwise until the cut engagement (58) lever is nearly vertical.

### **IMPORTANT**

Do not pull the recoil starter cord to the end of its travel as it may cause damage to the engine or injury to the operator.  
When the engine starts, recoil the cord slowly.  
Do not allow the cord to snap back to its start position.

Open the engine fuel cock.

Set the throttle lever on the engine to approximately a halfway open position.

For cold engine starting, move the carburettor choke lever to the choke "full on" position.

Set the engine switch to the "on" position.

Where fitted, pull the Hold to run lever towards the handle bar.

Pull the recoil starter cord handle.

After the engine starts, open the choke approximately halfway, or until the engine runs smoothly. Warm the engine up for 2~3 minutes at half engine speed before opening the choke fully.

The warm up procedure is particularly important during cold weather.

**Electric models:** Follow instructions in Starting at paragraph three, then pull the Hold to run lever towards the handle bar, press start button on control box. Continue instructions with item 2,3 and 4 in Machine Operation below.

## Machine Operation

Ensure that the depth of cut adjustment hand wheel is in the fully raised position and the cut engagement lever is up.

On Petrol engines set the throttle lever on the engine to fully "open/run" position.

Continue holding the handle bar and dead mans handle in the "on" position.

Place the cut engagement lever in the forward engaged position and slowly rotating clockwise the depth of cut hand wheel (55).

The cut engagement lever (58) will move forward/down while adjustment is made, if it does not, ensure that the cut engagement lever has been pushed to the forward position.

Adjust the depth of cut hand wheel until the cutters are in contact with the surface, slowly adding more cut until sufficient material is being removed. Be aware that several lighter cuts is more efficient than one heavy cut. Heavy cuts will only increase wear of drum components and increase operator fatigue.

The Planer may move forward during the cutting operation, due to the action of the cutter drum. Control this by holding the handle bar. When planing rough surfaces the machine may jerk forwards if too heavy a cut is made. Reduce the amount of cut by raising the cutters via the cutting depth adjustment hand wheel (55).

When the end of the run has been completed, end the cut by raising the cutter engagement/disengagement lever (58).

Position the machine for the next run, and then slowly lower the cutter engagement lever again.

### **ENGINE VERSIONS CAUTION**

Beware of **POISONOUS FUMES**. Start and operate only in well-ventilated areas.  
Be careful with **HOT COMPONENTS**. Exhausts and other engine parts are hot during and for some time after operation.  
Do not touch them.

## Shut Down

### All Versions

Raise the cutters using the drum cutting depth adjustment hand wheel (55).

Lift the cutter engagement / disengagement (58) lever to the raised position.

**Electric version only**, now release the hold to run lever, the electric motor will then stop.

### Petrol Engine Versions

Move the engine's throttle lever to the slow speed position and run the engine for 20 seconds. (This avoids the engine bore from becoming washed internally by neat fuel.) Where fitted, release the hold to run lever on the machines handle bar, the engine will now stop.

Switch off the engine's ignition switch.  
Close the engine fuel cock.

### **: EMERGENCY SHUTDOWN :**

Where fitted, Release Hold to run lever on the handle bar or switch off the ignition switch on the engine.

## Machine Storage

### Short period storage: up to 3months.

Clean outside of machine, remove drum and inspect for wear, replace any worn parts as required.

Remove any build up of material from inside of drum housing area; spray drum with a light coating of suitable anti rust agent.

*See also engine manufactures operation and maintenance instruction book.*

Cover the machine to protect it: Store the Planer in a dry place.

### Long period storage: over 3months

Clean outside of machine, remove drum and inspect for wear, replace any worn parts as required.

Remove any build up of material from inside of drum housing area; spray drum with a light coating of suitable anti rust agent.

When engine is cold, remove the fuel from the fuel tank and carburettor float chamber; see engine manufactures operation and maintenance instruction book for method.  
Electric Motors only, protect plug and motor against corrosion and moisture.

Cover the machine to protect it: Store the Planer in a dry place.

# SERVICING continued

## Belt Removal & Installation

Remove the belt Guard by unscrewing the 8mm and 10mm securing bolts. Slacken off the engine/motor mounting plate bolts and loosen both belt adjusting bolts locking nuts. Unscrew the adjuster bolts (39) to loosen the drive belt, and then slide the toothed belt (34) off the drive pulley (28).

Fit a new belt onto the pulleys as described above.

Adjust the belt tension using the belt adjusting bolts (39) and then tighten the locknut against the engine mounting plate, ensure the belt tension is correct. (Do not over tighten)

Tighten all engine mounting plate bolts and locknuts.

Refit the belt guard (36) and tighten the retaining bolts.

### **IMPORTANT**

Normal slack should be approximately 13mm (1/2") when the belts are depressed in the middle position between the engine/motor pulley and drum pulley.

## MAIN ASSEMBLY

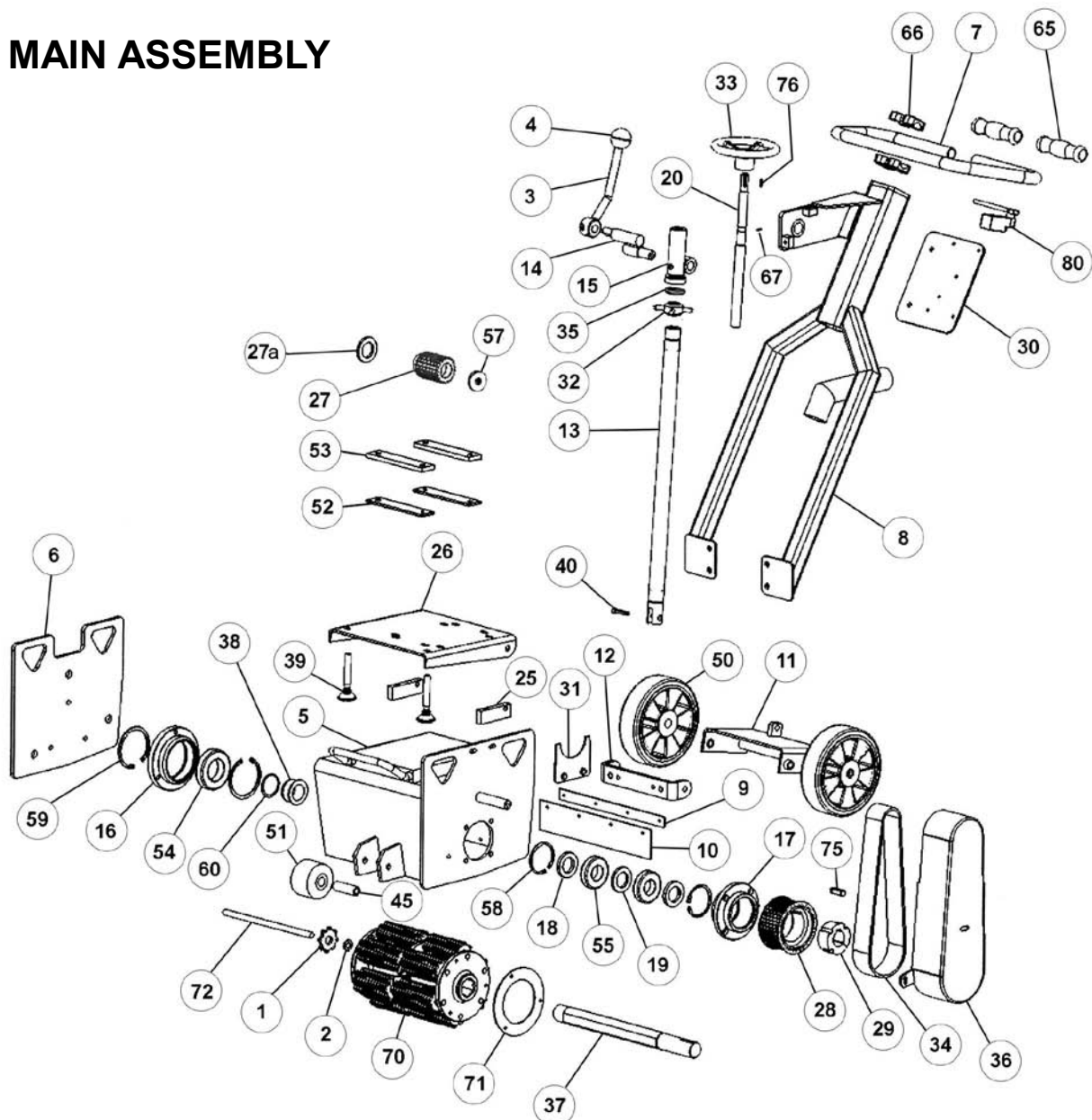

Item	Part Number	Description	Item	Part Number	Description
1	320.7009	TCT Cutters (123 req)	45	326.9150	Front Wheel Spacer
		Star Cutters (Not Shown) (342 req)			
	326.5120	Beam Cutters (Not Shown) (332 req)	50	350.9121	Rear Wheel 150mm dia
	320.5680	Milling Cutters (Not shown) (60 req)	51	326.9161	Front Wheel 82mm dia
2	320.4151	Spacers (12mm shafts prior to Nov12)	52	326.9163	Electric Motor Clamping Plate
	320.4160	Spacers (16mm shafts Nov12 onwards) (154req)	53	326.9164	Electric Motor Mounting Plate
3	325.9131	Lift Lever	54	326.9165	Large Bearing (Side Plate Side)
4	325.9170	Lift Lever Ball Knob	55	326.9166	Small Bearing x 2 (Drive Plate Side)
5	326.9100	Cutter Drum Box			
6	326.9101	Side Plate	57	326.9168	Electric Pulley Retaining Washer
7	326.9103	Handle Bar		325.9167	Engine Pulley Retaining Washer
8	326.9105	Handle Assembly	58	814.3205	Circlip x 2 (Drive Side Bearing)
9	326.9106	Dust Skirt Retainer	59	814.3210	Circlip x 2 (Side Plate Bearing)
10	326.9107	Dust Skirt	60	814.3215	Circlip external (Drive Bush)
11	326.9110	Swing Arm			
12	326.9111	Axle Mounting Bracket	65	822.2000	Rubber Grip
13	326.9112	Lift Rod Assembly	66	835.9120	Alloy Clamp
14	326.9113	Lever Quadrant	67	858.1006	Grease Nipple
15	326.9114	Lift Nut			
16	326.9115	Side Plate Bearing Housing	70	326.06DW	Double Web Drum (16mm shafts) (standard fit)
17	326.9116	Drive Side Bearing Housing		326.060G	Grooving drum (16mm shafts)
18	326.9117	Outer Bearing Spacer (2 x required)			
19	326.9118	Inner Bearing Spacer		326.1016DT	Drum D/Web Beam (16mm shafts)
20	326.9119	Lift Rod Shaft		326.1016DS	Drum D/Web Star (16mm shafts)
				326.1016GT	Grooving drum TCT (16mm shafts)
25	326.9121	Block (Engine/Motor Mounting Plate)			
26	326.9125	Engine/Motor Mounting Plate			
27	326.9126A	Electric Motor Pulley			
	326.9126	Petrol Engine Pulley			
27a	326.9127	Petrol Engine Pulley Spacer	71	326.00EP	End Plate (2 x required)
28	326.9128	Drive Pulley	72	326.0010	6 x Cutter Shaft (12mm shafts prior to 26.11.12)
29	326.9129	Taper Lock Bush		326.0016	6 x Cutter Shaft (16mm shafts 26.11.12 onwards)
30	326.9130	Starter Box Mounting Plate			
			75	855.1008	Drive shaft pulley key
32	326.9135	Locking Wheel	76	855.4414	Hand wheel key
33	326.9136	Hand Wheel	77	326.9109	Axle Spacer
34	326.9137	Drive Belt (Electric)			
	326.9137A	Drive Belt (Petrol)	80	345.9805	Deadmans switch
			85	326.9134	Rear Guard (Petrol engine only)
35	326.9138	Thrust Bearing			
36	326.9139	Belt Guard	<b>Not shown in exploded diagram</b>		
				325.9141	8hp Honda Engine
37	326.9140	Drive Shaft		325.9185	415v 3ph 50/60hz Electric Motor
38	326.9140A	Drive Shaft Bush		325.9186	Starter Control Box 380/420v 50/60hz
39	326.9143	Belt adjuster bolt			
40	326.9144	12mm Clevis Pin		853.1725	Honda engine pulley retaining countersunk screw

# TECHNICAL SPECIFICATIONS

## Technical Specifications

Height	1080mm	42.5"
Width	480mm	19"
Length	1010mm	40"
Cutting width	240 mm	9.4 inch
Average depth of cut (concrete with no aggregate)	6mm	0.25 inch
Drum rpm approximately	1850 rpm petrol, 1750 rpm electric	
Working distance from wall	75mm	3.0"
Weight	140 kg	308.5lbs
Power unit	8 hp Honda	5.96 kilowatt
Approximate Fuel Consumption	2.0 litre per hour	0.43 Gallon per hour
Power unit	7.5 hp Electric	415v 3ph 5.5kw
Noise L <sub>WA</sub> - Declared noise emissions in accordance with BS ISO03744:2010 And BS EN ISO 15744:2008	102.5dB (A)	
Vibration (AEQ) - at the handle bar	Petrol engine version	8.8 m/s <sup>2</sup> (K= +40% -0%
	Electric motor version	2.4 m/s <sup>2</sup> (K= +40% -0%

(k) \*\* Equals the factor of uncertainty, which allows for variations in measurement and production. Vibration Data figures are tri-axial, which gives the total vibration emission. Because of various factors, the range of vibration from these tools may vary between 2.4m/s<sup>2</sup> & 12.3m/s<sup>2</sup>. The vibration is dependent on the task, the operators grip and feed force employed etc.

NOTE: The above vibration levels were obtained from tri-axial measurements to comply with the requirements of "The Control of Vibration at Work Regulations 2005" and the revisions to the (8662) now EN ISO 28927:2012 and EN ISO 20643:2005 series of standards. These values are at least 1.4 times larger than the values obtained from single axis measurements.

Based on European Union Council Directive 2002/44/EC (Physical Agents (Vibration) Directive)

**This tool has been designed and produced in accordance with the following directives:**

If your company has any problem with our products or would like to discuss the possibility of an improvement being made to them, then please do not hesitate to contact us. Your comments are both important and appreciated.

## Trouble Shooting

FAULT	CAUSE	ACTION
Engine stops suddenly or does not run correctly	No fuel in the fuel tank.	Refuel fuel tank. (See safety section.)
	Spark plug faulty.	Replace spark plug.
	Fuel blockage.	Check fuel line and strainer.
	Air cleaner blocked.	Replace air cleaner element.
Electric motor stops suddenly	Low oil level.	Rectify leaks and replenish oil.
	Blown electrical supply fuse.	Replace fuse.
Electric motor will not start	Motor overload protection activated	Disconnect electricity supply at mains and reset button inside starter box.
	Deadmans handle not engaged	Pull Deadmans level against handle bar and press start button.
Planer is slow or erratic	Drive Belt slack or failed teeth.	Replace Belts or adjust tension.
	Worn Drum Cutters	Replace Cutters.
	Surface too rough.	Use Trelawny TFP380 Planer to increase production.
Engine will not start	No fuel in the fuel tank.	Refuel fuel tank, see safety precautions.
	Low oil level.	Rectify leaks, replenish oil.
	Water in fuel.	Drain fuel tank, float chamber, and refuel.
	Spark plug faulty.	Replace spark plug.
Engine will not turn over	Oil in Cylinder.	See page 2 - section. <b>Safety</b> .
Use above information in conjunction with the engine manufacturers Operation and Maintenance Manual.		
If problem has not been cured by above actions, contact your local Trelawny agent or engine manufacturer for advice or rectification.		

All rights reserved. Any unauthorised use or copying of the contents or part thereof is prohibited. This applies to trademarks, model denominations, part numbers and drawings. Use only genuine Trelawny spares.

**The use of non-Trelawny spare parts invalidates the warranty.**

# TRELAWNY

SURFACE PREPARATION TECHNOLOGY

Distributed exclusively by:



22 Harbor Avenue, Norwalk, CT 06850 USA

Toll-Free: 800-700-5919

Phone: 203-853-9522

Fax: 203-853-9921

Email: info@csunitec.com

[www.csunitec.com](http://www.csunitec.com)