

Tuff Form Ultimate Linear Shower Base

Product Overview

Made from lightweight yet durable compression molded glass-fiber reinforced plastic (GRP), the Tuff Form Ultimate Linear Shower Base can support up to 840lbs without modifying joists and creates one continuous pitch to the discreet linear tile-in drain, making it ideal for large format tile or stone.

Tuff Form Ultimate Linear bases offer the timeless advantage of level-entry access, which makes the shower easier to clean, safer to use, and more accessible to seniors, people with health conditions, or those in wheelchairs.

Features & Benefits

- + Made from lightweight yet strong compression molded glass-fiber reinforced plastic (GRP), ideal for accessible showers
 - + Install on wood or engineered joist systems, on subfloor, or concrete
 - + Install multiple adjacent bases to create a larger showering area
 - + Can support up to 840lbs when installed on 16" o.c. joist systems supplemented with perimeter and drain hole blocking
 - + Curbless, barrier-free design increases safety by reducing trip hazards and providing access for seniors, people with disabilities, or those in wheelchairs
 - + Waffle design on underside of base increases strength while reducing weight
 - + Cut and drill as needed with standard power tools
 - + Can be used to create an ADA compliant shower, seek guidance locally for more information about compliancy and building regulations
 - + One large pre-sloped gradient plane for quick, efficient drainage which reduces the risk of pooling or flooding
 - + Pre-drilled, countersunk pilot holes along perimeter for easy installation
- + 2" drain outlet is the only part sitting below the floor joist system
 - + Discreet tile-in linear drain cover runs the width of the base and can be tiled to match the rest of the shower floor for an enhanced cosmetic finish
 - + Stainless-steel edge trims ensure a tidy joint between the pitched base and adjacent level floor in open-sided installations (available a la carte)
 - + Complete installation with an AKW Waterproofing Kit (available a la carte)
 - + Finish with decorative tile or stone; continuous pitch is ideal for large format tile or stone
 - + Durable and re-useable; remove and replace tile without damaging the structure of the base

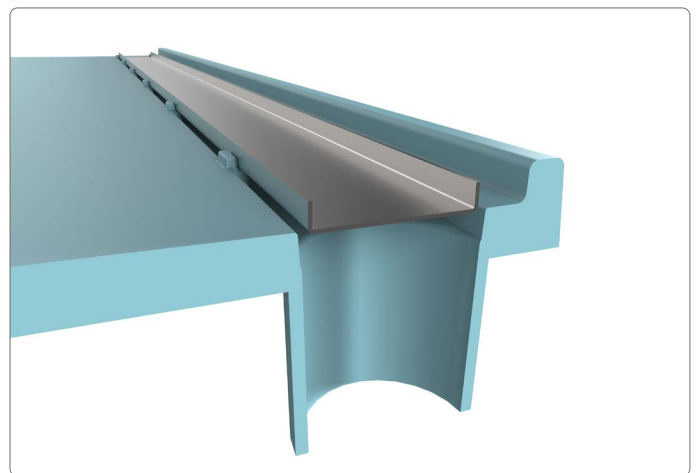
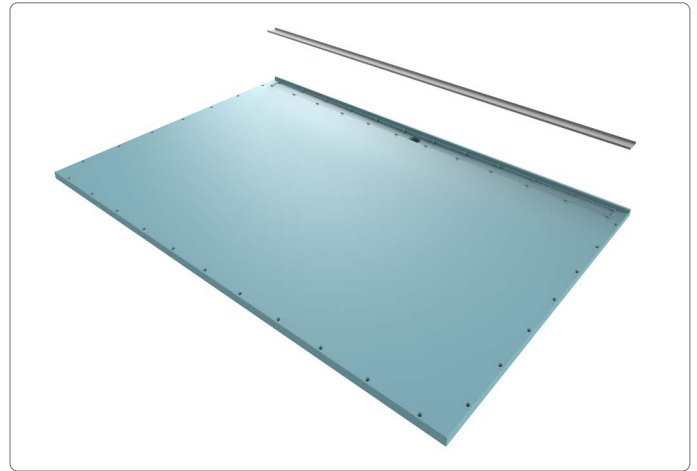

Technical Specification

- + Size: 72" x 48"
- + Materials: Compression molded glass-fiber reinforced plastic (GRP) base, stainless-steel drain cover, PVC drain connector
- + Weight Capacity: 840lbs
- + Weight: approx. 106lbs
- + Gradient: $\geq 1\%$ per foot
- + Perimeter: 1 1/8" thick
- + Spans 16" o.c. joist systems
- + Drain hole diameter: 2"
- + Standard 2" PVC drain connector supplied
- + Tileable linear drain cover supplied
- + Stainless-steel side trims available (a la carte) for open-sided installations
- + Suitable for use with underfloor heating
- + Can be finished with tile or stone

Compliance

a. ICC PMG-1223 lists compliance with:

- 1 2015, 2012 and 2009 International Residential Code® (IRC)
- 2 2015, 2012 and 2009 International Plumbing Code® (IPC)
- 3 2015, 2012 and 2009 Uniform Plumbing Code® (UPC)
- 4 2010 and 2005 National Plumbing Code of Canada (NPC)
- 5 IAPMO PS106-2015e1 for prefabricated, tileable shower receptors
- 6 CSA B45.5/IAPMO Z124-2011, Plastic Plumbing Fixtures

b. QAI Laboratories test report no. RJ4241-1:

- 1 Meets conditions of classification for 30-minute flame spread index and smoke developed index per ASTM E84 requirements

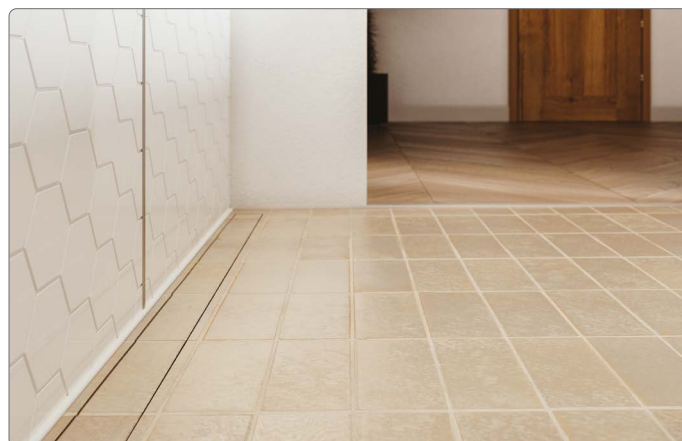
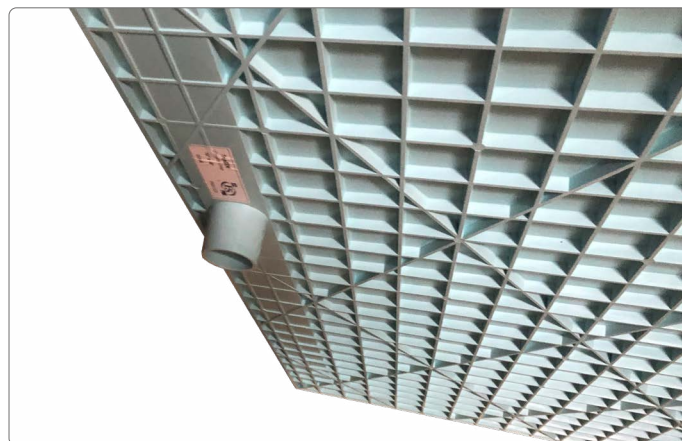

Warranty & Approvals

- + AKW Limited lifetime warranty
- + Can be used to create an ADA compliant shower



Dimensions

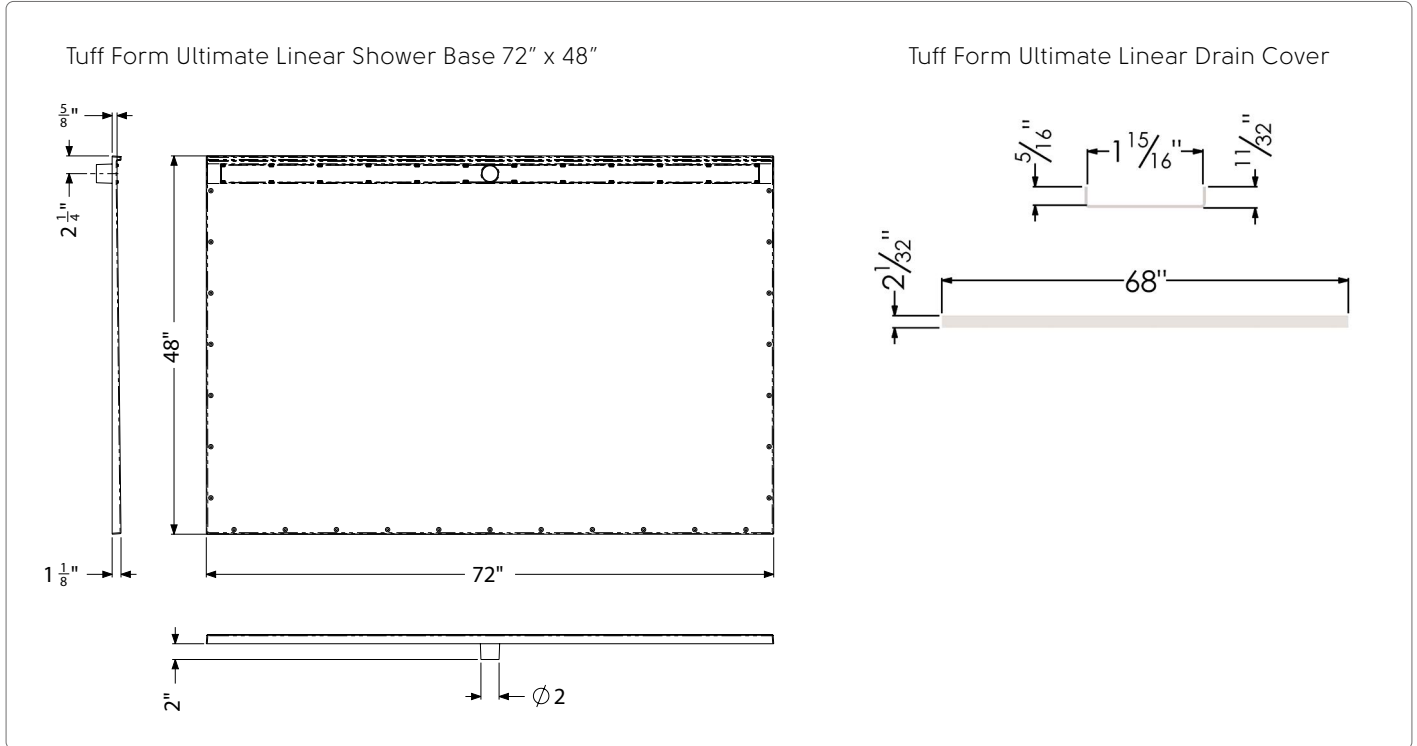

Product Codes

Tuff Form Ultimate Linear Shower Base 72" x 48" 21240

Waterproofing Kits

Premium Waterproofing Kit	WP1000-PRE
Pro Waterproofing Kit	WP1090-PRO

A La Carte Items

Tuff Form Ultimate Linear Edge Trim 1/4" Tile (Right)	21241R
Tuff Form Ultimate Linear Edge Trim 1/4" Tile (Left)	21241L
Tuff Form Ultimate Linear Edge Trim 3/8" Tile (Right)	21242R
Tuff Form Ultimate Linear Edge Trim 3/8" Tile (Left)	21242L
Tuff Form Ultimate Linear Edge Trim 1/2" Tile (Right)	21243R
Tuff Form Ultimate Linear Edge Trim 1/2" Tile (Left)	21243L

Spares

Tuff Form Ultimate Linear Drain Cover	21-001-002
---------------------------------------	------------