



**WACKER
NEUSON**
all it takes!

Operator's manual

Rammer

**AS
BP**



Machine Type	AS30e, AS50e, AS60e
Material number	5100056974
Version	3.0
Date	06/2020
Language	[us]



Imprint

Publisher and copyright holder:

Wacker Neuson Produktion GmbH & Co. KG

Wackerstraße 6

85084 Reichertshofen, Germany

Registered office: Reichertshofen

Register court and number: Local Court Ingolstadt, HRA3195

VAT ID No./VAT Number: DE277138620

Telephone: +49 (0) 8453-3403200

www.wackerneuson.com

Original operator's manual

All rights reserved, in particular the copyright, the right of reproduction and the right of distribution applicable worldwide.

This document may be used by the recipient only for the designated purpose. It may in no way be duplicated or translated in any other language, in whole or in part, without prior permission in writing from the manufacturer.

Reproduction or translation of this publication, in whole or part, is not permitted without the written consent of Wacker Neuson Produktion GmbH & Co. KG.

Violations of legal regulations, in particular of the copyright protection, will be subject to civil and criminal prosecution.

Wacker Neuson Produktion GmbH & Co. KG reserves the right to change its products and their technical specifications for further technical development at any time without any claim to changes to machines already delivered. The information in the technical documentation supplied with the product applies in each case.

The machine on the cover is for illustration purposes only and may therefore have special equipment (options).

Wacker Neuson Produktion GmbH & Co. KG, responsibility for errors or omissions not accepted, printed in Germany

Copyright © 2020

Contents

1	California Proposition 65	
2	EC Declaration of Conformity	
3	EC Declaration of Conformity	
4	FCC Compliance Statement	
5	Preface	
5.1	Introduction	13
5.2	Storage location of the operator's manual	13
5.3	Accident prevention regulations.....	14
5.4	Wacker Neuson Contact.....	15
5.5	Limitation of liability.....	15
5.6	Labeling on the machine.....	15
5.7	Use of the operator's manual.....	16
6	Usage	
6.1	Designated use	17
6.2	Unintended use.....	17
7	Safety	
7.1	Safety symbols and signal words	18
7.2	Principle	18
7.3	Structural changes	19
7.4	Responsibility of the operator	19
7.5	Obligations of the operator	20
7.6	Qualification of staff	20
7.7	General safety instructions	20
7.8	Specific rammer-related safety instructions.....	22
7.9	Specific rechargeable-battery-related safety instructions	23
7.10	Specific charger-related safety instructions	25
7.11	Specific safety instructions when operating electrical appliances	26
7.12	Safety features.....	27
7.13	Maintenance	28
8	Description of the Machine	
8.1	Safety and information labels	30
8.2	Safety and information labels Accumulator	32
8.3	Safety and information label Battery transport box.....	33
8.4	Components	34
8.5	Control elements.....	34
8.6	Components and control elements accumulator	35
8.7	Components and operator's controls battery charger.....	36
9	Transportation	

9.1	Preparations	37
9.2	Lifting the machine	37
9.3	Lashing the machine	37
9.4	Packing and transporting rechargeable battery	38
9.5	Transporting battery charger	38
10	Commissioning	
10.1	Tests before commissioning	39
10.2	Charge the rechargeable battery	39
10.3	Install the rechargeable battery	39
10.4	Safety instructions for operation	40
11	Operation	
11.1	Putting into operation	42
11.2	Operating the machine	42
11.3	Check charge state of rechargeable battery	42
11.4	Putting out of operation	43
11.5	Remove the rechargeable battery	44
12	Maintenance	
12.1	Safety instructions for maintenance	45
12.2	Maintenance plan	46
12.3	Maintenance work	47
13	Malfunctions	
13.1	Machine	51
13.2	Accumulator	51
13.3	Battery charger	52
14	Shutdown	
14.1	Temporary decommissioning	53
14.2	Final shutdown	54
15	Accessories	
15.1	Transport roller	55
16	Technical Data	
16.1	General instructions	56
16.2	Noise and vibration data	56
16.3	Machine	56
16.4	Rechargeable battery	58
16.5	Battery charger	59
16.6	Extension cable	59
16.7	Conversion table	59

CALIFORNIA Proposition 65 Warning

CALIFORNIA Proposition 65 Warning



WARNING

The engine exhaust from this product contains chemicals known to the State of California to cause cancer, birth defects, or other reproductive harm.



WARNING

Diesel engine exhaust and some of its constituents are known to the State of California to cause cancer, birth defects, and other reproductive harm.



WARNING

Cancer and Reproductive Harm -
www.P65Warnings.ca.gov.



WARNING

Batteries, battery posts, terminals and related accessories contain lead and lead compounds, and other chemicals known to the State of California to cause cancer and birth defects or other reproductive harm. WASH HANDS AFTER HANDLING.





EC Declaration of Conformity

Manufacturer

Wacker Neuson Produktion GmbH & Co. KG, Wackerstraße 6, D-85084 Reichertshofen
This declaration of conformity is issued under the sole responsibility of the manufacturer.

Product	AS30e
Product type	Vibratory rammer
Function of product	Soil compaction
Material number	5100026851
Net installed power	1,34 kW
Measured sound power level	103 dB(A)
Guaranteed sound power level	108 dB(A)

Conformity assessment procedure

2000/14/EC, Annex VIII

Notified body

TÜV Rheinland LGA Products GmbH, Tillystr. 2, D-90431 Nürnberg (NB 0197)

Guidelines and standards

We hereby declare that this product complies with the relevant provisions and requirements of the following directives and standards:

2006/42/EC, 2000/14/EC, 2014/30/EU, EN 500-1:2006 + A1:2009, EN 500-4:2011, EN ISO 13766-1:2018, EN ISO 13766-2:2018

Person responsible for technical documents

Wacker Neuson Produktion GmbH & Co. KG, Wackerstraße 6, D-85084 Reichertshofen

Reichertshofen, 05.12.2019

Helmut Bauer
Managing Director



EC Declaration of Conformity

Manufacturer

Wacker Neuson Produktion GmbH & Co. KG, Wackerstraße 6, D-85084 Reichertshofen
This declaration of conformity is issued under the sole responsibility of the manufacturer.

Product	AS50e
Product type	Vibratory rammer
Function of product	Soil compaction
Material number	5100053792
Net installed power	2,1 kW
Measured sound power level	102 dB(A)
Guaranteed sound power level	108 dB(A)

Conformity assessment procedure

2000/14/EC, Annex VIII

Notified body

TÜV Rheinland LGA Products GmbH, Tillystr. 2, D-90431 Nürnberg (NB 0197)

Guidelines and standards

We hereby declare that this product complies with the relevant provisions and requirements of the following directives and standards:

2006/42/EC, 2000/14/EC, 2014/30/EU, EN 500-1:2006 + A1:2009, EN 500-4:2011, EN ISO 13766-1:2018, EN ISO 13766-2:2018

Person responsible for technical documents

Wacker Neuson Produktion GmbH & Co. KG, Wackerstraße 6, D-85084 Reichertshofen

Reichertshofen, 05.12.2019

Helmut Bauer
Managing Director



EC Declaration of Conformity

Manufacturer

Wacker Neuson Produktion GmbH & Co. KG, Wackerstraße 6, D-85084 Reichertshofen
This declaration of conformity is issued under the sole responsibility of the manufacturer.

Product	AS60e
Product type	Vibratory rammer
Function of product	Soil compaction
Material number	5100052267
Net installed power	2,24 kW
Measured sound power level	105 dB(A)
Guaranteed sound power level	108 dB(A)

Conformity assessment procedure

2000/14/EC, Annex VIII

Notified body

TÜV Rheinland LGA Products GmbH, Tillystr. 2, D-90431 Nürnberg (NB 0197)

Guidelines and standards

We hereby declare that this product complies with the relevant provisions and requirements of the following directives and standards:

2006/42/EC, 2000/14/EC, 2014/30/EU, EN 500-1:2006 + A1:2009, EN 500-4:2011, EN ISO 13766-1:2018, EN ISO 13766-2:2018

Person responsible for technical documents

Wacker Neuson Produktion GmbH & Co. KG, Wackerstraße 6, D-85084 Reichertshofen

Reichertshofen, 05.12.2019

Helmut Bauer
Managing Director



EC Declaration of Conformity

Manufacturer

Wacker Neuson Produktion GmbH & Co. KG, Wackerstraße 6, D-85084 Reichertshofen
This declaration of conformity is issued under the sole responsibility of the manufacturer.

Product	C48/4
Product type	Battery Charger
Function of product	Charging the battery
Material number	5100006221

Guidelines and standards

We hereby declare that this product complies with the relevant provisions and requirements of the following directives and standards:

2014/35/EU, 2014/30/EU, 2011/65/EU, EN 55014-1:2017, EN 55014-2:2015, EN 60335-1:2012 + A11:2014 + AC:2014 + A13:2017, EN 60335-2-29:2004 + A2:2010 + A11:2018

Person responsible for technical documents

Wacker Neuson Produktion GmbH & Co. KG, Wackerstraße 6, D-85084 Reichertshofen

Reichertshofen, 24.09.2019

Helmut Bauer
Managing Director



EC Declaration of Conformity

Manufacturer

Wacker Neuson Produktion GmbH & Co. KG, Wackerstraße 6, D-85084 Reichertshofen
This declaration of conformity is issued under the sole responsibility of the manufacturer.

Product	BP1000, BP1400
Product type	Accumulator
Function of product	Power supply
Material number	5100025709, 5100048620

Guidelines and standards

We hereby declare that this product complies with the relevant provisions and requirements of the following directives and standards:

2014/53/EU, 2014/30/EU, EN 60950-1:2006 + A11:2009 + A1:2010 + AC:2011 + A12:2011 + A2:2013, EN 301 489 V1.9.2 , EN 300 328 V2.1.1

Person responsible for technical documents

Wacker Neuson Produktion GmbH & Co. KG, Wackerstraße 6, D-85084 Reichertshofen

Reichertshofen, 16.03.2020

Helmut Bauer
Managing Director



Supplier's Declaration of Conformity 47 CFR § 2.1077 Compliance Information

Manufacturer

Wacker Neuson Produktion GmbH & Co. KG, Wackerstraße 6, D-85084 Reichertshofen

Product	BP1000, BP1400
Product type	Accumulator
Material number	5100025709, 5100048620
Modular component	Panasonic PAN1762
FCC Identifier	T7V1762

Responsible Party - U.S. Contact Information

Wacker Neuson Corporation
N92 W15000 Anthony Avenue
Menomonee Falls, WI 53051-1504
technical.support@wackerneuson.com

FCC Compliance Statement

This product complies with Part 15 of the FCC Rules. Operation is subject to the following two conditions: (1) This product may not cause harmful interference, and (2) this product must accept any interference received, including interference that may cause undesired operation.

Note: This product has been tested and found to comply with the limits for a Class A digital device, pursuant to Part 15 of the FCC Rules. These limits are designed to provide reasonable protection against harmful interference when the product is operated in a commercial environment. This product generates, uses, and can radiate radio frequency energy and, if not installed and used in accordance with the operator's manual, may cause harmful interference to radio communications. Operation of this product in a residential area is likely to cause harmful interference in which case the user will be required to correct the interference at his own expense.

Caution: Changes or modifications not expressly approved by the party responsible for compliance could void the user's authority to operate the product.



Supplier's Declaration of Conformity 47 CFR § 2.1077 Compliance Information

Copy of the Compliance Information Statement

TCB

TCB

GRANT OF EQUIPMENT
AUTHORIZATION
Certification
Issued Under the Authority of the
Federal Communications Commission

By:

Eurofins Product Service GmbH
Storkower Strasse 38c
D-15526 Reichenwalde,
Germany

Date of Grant: 05/13/2019

Application Dated: 05/13/2019

Panasonic Industrial Devices Europe GmbH
Zeppelinstrasse 19
Lueneburg, 21337
Germany

Attention: Olaf Knoth , Product Safety

NOT TRANSFERABLE

EQUIPMENT AUTHORIZATION is hereby issued to the named GRANTEE, and is VALID ONLY for the equipment identified hereon for use under the Commission's Rules and Regulations listed below.

FCC IDENTIFIER: T7V1762

Name of Grantee: Panasonic Industrial Devices Europe GmbH

Equipment Class: Digital Transmission System

Notes: Bluetooth Low Energy Module

Modular Type: Single Modular

Grant Notes	FCC Rule Parts	Frequency Range (MHZ)	Output Watts	Frequency Tolerance	Emission Designator
	15C	2402.0 - 2480.0	0.0061		

Single Modular Approval. Output power listed is peak conducted. This device is to be used for portable and mobile applications. The antenna(s) used for this transmitter must not be collocated or operating in conjunction with any other antenna or transmitter, except in accordance with FCC multi-transmitter product procedures. OEM integrators and end-users must be provided with specific information required to satisfy RF exposure compliance, antenna installation and labeling requirements for the final host device.

5 Preface

5.1 Introduction

This operator's manual contains important information and procedures for the safe, proper and economical operation of this Wacker Neuson machine. Carefully reading, understanding and observing it helps to avoid dangers, reduce repair costs and downtimes and thus increase the availability and service life of the machine.

This operator's manual is not a manual for extensive maintenance or repair work. Such work must be carried out by Wacker Neuson Service or by technically trained personnel. The Wacker Neuson machine must be operated and maintained in accordance with the instructions in this operator's manual. Improper operation or maintenance can cause hazards.

Defective machine parts must be replaced immediately!

Wacker Neuson contact persons are always available to answer questions about operation or maintenance.

5.2 Storage location of the operator's manual

This operator's manual must be kept in the immediate vicinity of the machine and accessible to personnel at all times.

If this operator's manual is lost or you require a new copy, there are two ways of obtaining a replacement:

- You can download it from the Internet - <http://www.wackerneuson.com>
- Or you can contact your Wacker Neuson representative.

5.2.1 Understanding these instructions

This section helps to understand the operator's manual and the illustrations used therein.



Target group

Persons, working with this machine, must be regularly trained with regard to the dangers and risks occurring when using this machine.

This operator's manual is aimed at:

- Operating personnel:
 - These persons have been instructed in working with the machine and about possible dangers and risks arising due to improper behavior.
- Technically trained personnel:
 - These persons have a professional training as well as additional knowledge and experience. They are capable of assessing the tasks assigned to them and recognizing any possible risks and dangers.

Explanation of symbols

Symbol	Explanation
1., 2., 3...	Indicates an activity. The sequence of the steps must be observed.
⇒	Indicates a result or an intermediate result of an action.
✓	Indicates prerequisites that must be established for the activity.
•	Indicates a list, e.g. if several components are named one after the other.
-	Indicates a sub-list, e.g. if components consist of further components
	Identifies a position, usually a component or control element, in a graphic. The numbering may be sequential or in Roman numerals.
1; A	Indicates the naming of components in explanatory texts. It is identical with the adjacent positions in the illustrations.
 	Indicates a direction of movement or different positions for switches.
▶	Indicates the avoidance of hazards in warning notices.
[▶52]	Indicates a cross-reference in tables. Here e.g. reference to page 52

Explanation of symbols



Symbol for warning notices

This symbol is a warning symbol. It is used to alert you to potential hazards. The safety symbol is always followed by a signal word, which indicates the hazard. These warnings are to be observed in particular. This protects the operator and third parties from personal injury and damage to property.



Symbol for environmental information

This symbol indicates environmental information. It is used to warn of possible environmental hazards.



Symbol for information

This symbol indicates information. This information can include tips on operation, for example. It helps to better understand and use the machine.



Symbol crossed-out waste bin

This symbol means that the machine must not be disposed of with normal household waste, but in a separate collection in an environmentally friendly manner.

5.3 Accident prevention regulations

In addition to the notes and safety instructions in this operator's manual, the local accident prevention regulations and the national industrial safety regulations apply.

5.4 Wacker Neuson Contact

Depending on the country, the Wacker Neuson contact is a Wacker Neuson Service, a Wacker Neuson subsidiary or a Wacker Neuson dealer.

On the Internet at - <http://www.wackerneuson.com>.

5.5 Limitation of liability

In the event of the following infringements, the manufacturer disclaims any liability for personal injury and damage to property:

- Actions contrary to this operator's manual.
- Non-designated use
- Deployment of untrained personnel.
- Use non-approved spare parts and accessories.
- Improper handling.
- Structural changes of any kind.
- Non-observance of the General Terms and Conditions (GTC).

5.6 Labeling on the machine

Type label data

The type label contains information that uniquely identifies this machine. This information is required for ordering spare parts and for technical queries.

Enter the data on the machine in the following table:

Designation	Your details
Group - Type	
Material number (Mat. no.)	
Machine version (version)	
Machine number (machine no.)	
Year of construction	

5.7 Use of the operator's manual

This operator's manual:

- must be regarded as an integral part of the machine and must be kept in a safe place throughout its service life.
- must be passed on to each subsequent owner or operator of this machine.
- applies to various machine types from one product range. For this reason, some illustrations may differ from the appearance of the purchased machine. Variant-dependent components that are not included in the scope of delivery can also be described.

Wacker Neuson reserves the right to change the information in this operator's manual without notice.

It must be ensured that any changes or additions made by the manufacturer are immediately incorporated into this operator's manual.

The following will be described:

Machines

Group - Machine type	Material number (Mat. no.)
AS30e	5100026851
AS50e	5100053792
AS60e	5100052267

Accessories

Group - Machine type	Material number (Mat. no.)
C48/4	5100006221
BP1000	5100025709
BP1400	5100048620
Battery transport box	5100051760

6 Usage

6.1 Designated use

Designated use also includes observing all notes and safety instructions in this operator's manual and observing the prescribed care and maintenance instructions.

Any other use or use that goes beyond this is considered improper use. The manufacturer shall not be liable or liable for any damage resulting therefrom. The risk is borne solely by the operator.

The machine:

- Use to compact cohesive, mixed and granular soils.
- Only combine and operate with permissible components.
- Only use rechargeable batteries permitted by the manufacturer.
- Only operate with accessories permitted by the manufacturer.

6.2 Unintended use

The manufacturer is not liable for personal injury or damage to property resulting from unintended use. The following activities, among others, are not intended:

- Connecting non-permitted components.
- Operating the machine outside the performance data.
- Operation contrary to the notes and safety instructions contained in the operator's manual attached to the machine.
- Operation in an potentially explosive environment!
- Operation in the vicinity of open flames. Fire hazard!
- Compaction of strongly cohesive soils.
- Compaction of frozen soils.
- Compaction of hard, non-compactable soils.
- Compaction of non-load-bearing soils.
- Shaking in cobblestones.

7 Safety

7.1 Safety symbols and signal words

The following symbol identifies safety instructions. It is used for warning against potential personal risk or danger.



DANGER

DANGER identifies a situation causing death or serious injury if it is not avoided.

Consequences in case of non-observance.

- ▶ Avoidance of injury or death.



WARNING

WARNING identifies a situation that can cause death or serious injury if it is not avoided.

Consequences in case of non-observance.

- ▶ Avoidance of injury or death.



CAUTION

CAUTION identifies a situation that can cause injury if it is not avoided.

Consequences in case of non-observance.

- ▶ Avoidance of injury.



NOTICE

INFORMATION identifies a situation that causes damage if it is not observed.

Consequences in case of non-observance

- ▶ Avoidance of damage to property.

7.2 Principle

The machine has been designed and built in accordance with latest state-of-the-art standards and the recognized safety regulations. Nevertheless, improper use may result in danger to life and limb of the operator, third parties or damage to the machine and other material property.

Read and observe the notes and safety instructions in this operator's manual. Failure to follow these instructions may result in electric shock, fire and/or serious injury, and damage to the machine and/or other objects.

Keep safety instructions and information for the future.

7.3 Structural changes

Structural modifications may not be made without the written consent of the manufacturer. Unauthorized structural changes may result in hazards to the operator and/or third parties as well as damage to the machine.

The manufacturer's liability and warranty are also void in the event of unauthorized structural alterations.

In particular, a structural change shall be deemed to have occurred:

- When opening of the machine and permanent removal of components.
- Installation of spare parts that do not come from Wacker Neuson or are not equivalent in design and quality to the original parts.
- Attachment of accessories of any kind that do not originate from Wacker Neuson.

Spare parts or accessories from Wacker Neuson can be installed or removed safely. Further information is available on the Internet at - <http://www.wackerneuson.com>.

7.4 Responsibility of the operator

The operator is the person who operates this machine himself for commercial or economic purposes or who leaves it to a third party for use/application and bears the legal product responsibility for the protection of personnel or third parties during operation.

The operator must make the operator's manual accessible to the personnel at all times and ensure that the operator has read and understood the operator's manual.

The operator's manual must be kept ready to hand at the machine or at the place of use.

The operator must hand over the operator to any other operator or subsequent owner of the machine.

The country-specific regulations, standards and directives on accident prevention and environmental protection must also be observed. The operator's manual must be supplemented by further instructions for compliance with operational, official, national or generally applicable safety guidelines.



7.5 Obligations of the operator

- Know and implement applicable health and safety regulations.
- In a risk assessment, identify hazards arising from working conditions at the place of use.
- Create operating instructions for the operation of this machine.
- Regularly check whether the operating instructions correspond to the current status of the regulations.
- Clearly regulate and define responsibilities for installation, operation, troubleshooting, maintenance and cleaning.
- Train personnel at regular intervals and inform them about possible dangers.
- Refresh instruction at regular intervals.
- Keep records of the training received and make them available to the competent authority on request.
- Provide personnel with the necessary protective equipment.

7.6 Qualification of staff

This machine may only be put into operation and operated by trained personnel.

In the event of misuse, abuse or operation by untrained personnel, there is a danger to the health of the operators and/or third parties, as well as damage or total failure of the machine.

In addition, the following requirements apply to the operator:

- Physical and mental suitability.
- Minimum age 18 years.
- No influence on reactivity by drugs, alcohol or medication.
- Familiarity with the safety instructions in this operator's manual.
- Familiarity with the intended use of this machine.
- Instructed in the independent operation of the machine.

7.7 General safety instructions

The safety instructions in this chapter contain the "General safety instructions", which must be listed in the operator's manual in accordance with the applicable standards. It may contain instructions which are not relevant for this machine.

7.7.1 Workplace

- Before starting work, familiarize yourself with the working environment, e.g. load-bearing capacity of the floor or obstacles in the environment.
- Secure work area to public transport area.
- Necessary protection of walls and ceilings, e.g. in trenches.
- Keep unauthorized persons and children away when working with this machine. Distraction may result in loss of control of the machine, work must be carried out carefully.
- Always secure the machine against tipping, rolling, slipping and falling. Risk of injury!
- Keep work area tidy. Disorder or unlit work areas can lead to accidents.
- Observe the changing ground conditions, especially on uneven and soft ground or on slopes. Secure the machine against slipping!
- When working near pits, ditches or plateaus, exercise caution! The load-bearing capacity of the ground must safely carry the weight of the machine and the operator.

7.7.2 Personal safety

- Working under the influence of drugs, alcohol or medication can lead to serious injuries.
- Suitable protective equipment must be worn for all work. Personal protective equipment considerably reduces the risk of injury.
- Keep wide or loose clothing, protective gloves, jewellery and long hair away from moving machine parts. Danger of being drawn in!
- Always ensure that you are standing in a stable position, always stand with both feet on the ground.
- During prolonged work with this machine, long-term vibration-related damage cannot be ruled out completely. Vibration load, [see Technical Data on page 56](#).
- Ensure that there are no other persons in the danger zone!

Personal protective equipment



WARNING

Risk of hearing damage if the country-specific noise limit is exceeded!

Working with the machine without hearing protection can lead to hearing damage in the long-term.

- ▶ Wear ear protectors.
- ▶ Work attentively and cautiously when using hearing protection.



7.7.3 Handling and use

- Handle machines with care. Do not operate machines whose components or control elements are defective. Have defective components or control elements replaced immediately. Machines with defective components or control elements entail a high risk of injury!
- Do not lock, manipulate or alter the machine operating elements in an inadmissible manner.
- Secure unused machines against unauthorized commissioning. The machine may only be operated by authorized personnel.
- Handle machine with care. Have defective parts replaced immediately before this machine is commissioned. Defective machines entail a high risk of injury.
- Use the machine, accessories, tools etc. in accordance with these instructions.
- After operation, store the machine in a locked, clean, frost-protected, and dry location that is inaccessible to other persons and children.

7.8 Specific rammer-related safety instructions

7.8.1 External influences



WARNING

Fire and explosion hazard!

The use of machines in potentially explosive environments or near open flames may result in an explosion or a fire.

- ▶ Do not operate the machine in a potentially explosive environment.
- ▶ Do not operate the machine in the vicinity of open flames.
- ▶ Do not operate the machine in dry, highly flammable vegetation.

7.8.2 Operational safety



CAUTION

Risk of collapse and spillage!

There is a risk of injury from falling or spilling when working on fracture, pit, dump and embankment edges, on trench edges and heels.

- ▶ Pay attention to side walls and their stability.
- ▶ Ensure stability.

- When operating the machine, make sure that no gas, water or electrical lines or pipes are damaged.
- Exercise the utmost degree of caution near abysses or slopes.
- Never let the machine run unattended.
- Keep work area clear and keep unauthorized persons away.
- Make sure that persons located in the work area maintain a minimum distance of 2 meters from the running machine.
- Only use the manufacturer's rechargeable batteries. These are vibration resistant and therefore suitable for high vibration loads.

7

7.9 Specific rechargeable-battery-related safety instructions

7.9.1 External influences

- The rechargeable batteries may not be exposed to heat or fire. Avoid storage in direct sunlight.
- Do not expose rechargeable batteries to any mechanical impacts.
- Keep rechargeable batteries clean and dry. Do not allow them to come into contact with water.
- If the connections of rechargeable batteries become dirty, clean these with a dry and clean cloth.
- Keep paper clips, coins, keys, nails, screws and other small metal objects that could cause a bridging of the contacts away from rechargeable batteries. Danger of short circuit and fire!



7.9.2 Operational safety

- To charge the rechargeable batteries, only use the battery charger approved by the manufacturer.
- Rechargeable batteries may only be used in the machine specified by the manufacturer for this purpose.
- If a rechargeable battery is leaking, the fluid must not come into contact with your skin or eyes. If contact has been made, wash the affected area with plenty of water and seek immediate medical attention.
- If a rechargeable battery leaks, do not allow the contents to reach ground water, sewage system or soil.
- Observe the polarity as indicated on the rechargeable battery and the machine (+ and -). Ensure correct use.
- Do not use rechargeable batteries that are not intended for the machine.
- Charge rechargeable batteries before use. In this context, make sure that the correct charging procedure is used [see Start-up on page 39](#).
- Once the charge cycle is complete, the rechargeable battery is to be disconnected from the battery charger.
- Rechargeable batteries have their best power output if they are operated at normal room temperature (about 20 °C).

7.9.3 General information

- Do not take apart, open or deform rechargeable batteries.
- Do not short-circuit rechargeable batteries.
- Do not store rechargeable batteries in a box or draw as this can pose hazards where they can short out each other or be shorted out by another conductive material.
- Use rechargeable batteries for their intended purpose and protect them from damage.
- Keep rechargeable batteries away from children.
- Seek immediate medical attention if rechargeable battery components are swallowed accidentally.
- Use rechargeable batteries only in those applications for which they are intended.
- If possible, take the rechargeable battery out of the machine when it is not being used.
- If possible, take the rechargeable battery out of the machine when it is being loaded and transported.
- In the event of prolonged storage, remove the rechargeable battery from the machine and store it in the original battery transport box.
 - Store in a dry and well-ventilated room.
 - Observe storage temperature, [see technical data on page 56](#).
- Dispose of properly.
- In the event of fire:
 - Decommission the machine immediately.
 - Remove injured persons and others from the danger zone.
 - Stay away from vapors and gases, observe wind direction!
 - Extinguish only with water, do not use a direct stream of water.

7.10 Specific charger-related safety instructions

7.10.1 External influences

- Avoid penetration of water into the battery charger.
- Only use the battery charger indoors and keep away from rain and moisture.
- If it is not possible to avoid working in a damp environment, a residual current circuit breaker must be used.
- Always keep the battery charger clean and dry.
- Do not expose the battery charger to any mechanical impacts.
- If the connections are dirty, clean these with a dry and clean cloth.
- Protect the connection cable from any aggressive media (e.g. oil), sharp edges or moving machine parts.
- Do not operate the battery charger in freezing temperatures, [see Technical data on page 56](#).
- The battery charger may not be exposed to heat (e.g. direct sunlight) or fire.

7.10.2 Operational safety

- Damaged battery chargers may not be used.
- In case of malfunctions, disconnect the battery charger immediately from the power source.
- Only charge batteries permitted by the manufacturer.
- Damaged batteries may not be recharged.
- The battery charger's plug must fit in the plug receptacle. The plug may not be changed in any way. Do not use the adapter plug together with grounded machines.
- Avoid any contact with grounded surfaces.

7.10.3 General information



WARNING

Fire hazard!

The use of battery chargers in a flammable environment or near open flames may result in a fire.

- ▶ Do not operate the battery charger on easily flammable surfaces (e.g. paper, textiles) or in a flammable environment.

- Check the battery charger, cable and plug prior to every use and clean with a dry and clean cloth.
- Do not use the cable for carrying or suspending the machine. Do not pull the cable in order to pull the plug out of the receptacle.
- Do not use the battery charger if damage has been found. Do not open the battery charger yourself, but rather only have it repaired by qualified technically trained personnel who are using original spare parts.
- Only charge batteries permitted by the manufacturer.
- The battery charger's plug must fit in the plug receptacle. The plug may not be changed in any way. Do not use any adapters, since these are usually designed without a grounded conductor terminal.
- Avoid any physical contact with grounded surfaces (e.g. pipes, heaters).
- Once the charge cycle is completed, disconnect the rechargeable battery from the charger.
- Keep battery charger away from children.
- Dispose of battery charger properly.

7.11 Specific safety instructions when operating electrical appliances



NOTICE

Observe the respective national safety guidelines!

Extension cable

- Extension cables and cable drums must be unrolled completely prior to use.
- Only operate the machine with undamaged and tested extension cables! Damaged or tangled cables increase the risk of electric shock.
- Only use extension cables with grounding conductor and correct grounding conductor connection to plug and coupling (only machines of protection class I), [see Technical data on page 56](#).
- Only use tested extension cables that are suitable for use on construction sites:
 - H05RN-F or preferably – Wacker Neuson recommends H07RN-F, a SOOW cable or a country-specific equivalent version.
- Immediately replace damaged extension cables (e.g. cracks in the sheath) or loose plugs and couplings.
- Cable drums and multiple plug receptacles must meet the same requirements as extension cables.
- Protect extension cables, multiple plug receptacles sockets, cable drums and connectors from rain, snow or other wet conditions.

Protect power cables

- Do not use the power cord to pull or lift the machine.
- Do not pull the plug of the power cable out of the plug receptacle by the cable.
- Protect the power cord from heat, oil and sharp edges.
- If the power cord is damaged or the plug is loose, have the power cord replaced immediately by a Wacker Neuson service partner.

Protect from moisture

- When working outdoors, only use cables that are suitable for outdoor use.
- Use a residual current circuit breaker if it is not possible to avoid working in a damp environment.



NOTICE

Notice for cleaning the machine!

- ▶ Do not clean the machine with high pressure or steam cleaners!

7.12 Safety features

Safety features protect the operator of this machine from being exposed to the existing hazards. These are barriers (guards) or other technical measures. The source of danger is switched off or the danger is reduced in certain situations.

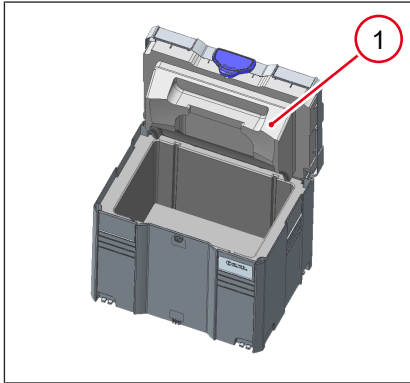

- 1 Cover insert
- Do not remove the cover insert 1.



Information

Regulations for the transport of dangerous goods!

If the cover insert is removed, the battery transport box no longer complies with the UN regulations for the transport of dangerous goods.

7.13 Maintenance

- This machine must not be serviced, repaired, adjusted or cleaned when switched on.
- Take out the rechargeable battery beforehand (depending on the machine).
- Observe maintenance intervals.
- Observe maintenance plan. Have Wacker Neuson Service perform any work not listed.
- Reinstall the safety devices on the machine after every maintenance or repair.
- Always replace worn or damaged machine parts immediately. Only use spare parts from the manufacturer.
- Keep the machine clean.
- Replace any missing, damaged or illegible safety labels immediately. Safety labels contain important information to protect the operator.
- Carry out maintenance work in a clean and dry environment (e.g. workshop).

7.13.1 Service

- Only have the machine repaired or serviced by technically trained personnel.
- Only use original spare parts and accessories. This ensures the operational safety of the machine.

Threaded fittings

All threaded fittings must comply with the specified specifications and be firmly bolted together. Observe the tightening torques! Screws and nuts must not be damaged, bent or deformed.

Particular attention should be paid to the following:

- Self-locking nuts and micro-encapsulated screws must not be reused after loosening. The fastening effect is lost.
- Threaded fittings with adhesive protection/liquid adhesives (e.g. Loctite) must be cleaned after loosening and provided with new adhesive.



Information

Observe the instructions of the liquid adhesive manufacturer.

8 Description of the Machine

8.1 Safety and information labels

AS30e

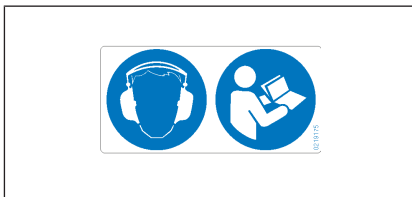

Wear personal protective equipment to avoid injury and health problems.

- Hearing protection.
- Read the operator's manual.

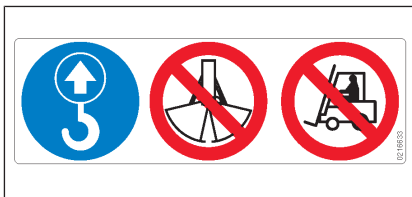

The falling machine can cause serious injuries.

- Only lift the machine at the central suspension with tested lifting gear and slinging gear (safety load hook).
- Do not use the excavator bucket to lift the machine by the central suspension.
- Do not use the forklift to lift the machine by the central suspension.

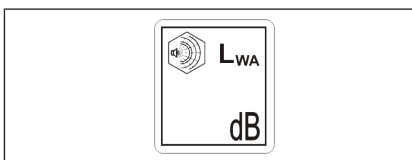

Guaranteed sound power level.

AS50e/AS60e

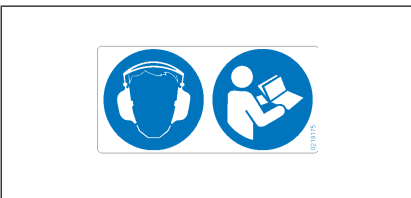
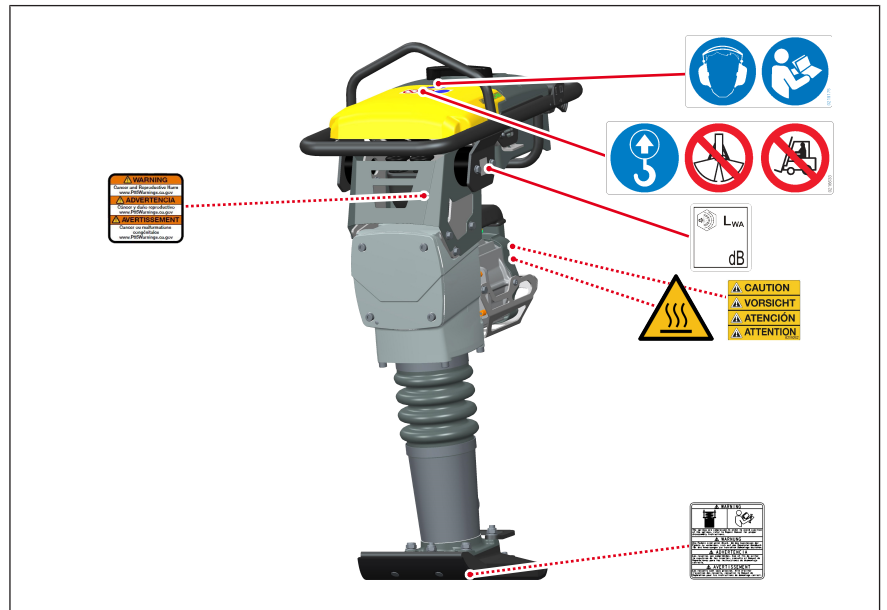

Wear personal protective equipment to avoid injury and health problems.

- Hearing protection.
- Read the operator's manual.

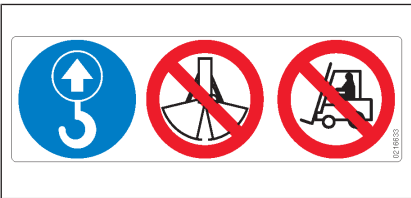

The falling machine can cause serious injuries.

- Only lift the machine at the central suspension with tested lifting gear and slinging gear (safety load hook).
- Do not use the excavator bucket to lift the machine by the central suspension.
- Do not use the forklift to lift the machine by the central suspension.

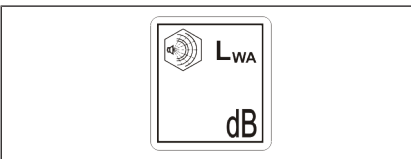

Guaranteed sound power level.



Risk of burns!

Warning of hot surface.



Caution!



Warning!

Release the cover slowly so that the spring does not pop out.

Read the repair instructions.



Warning of health risks

WARNING! CALIFORNIA: Proposition 65 (Safe Drinking Water and Toxic Enforcement Act of 1986)

For more information: www.P65Warnings.ca.gov

8.2 Safety and information labels Accumulator

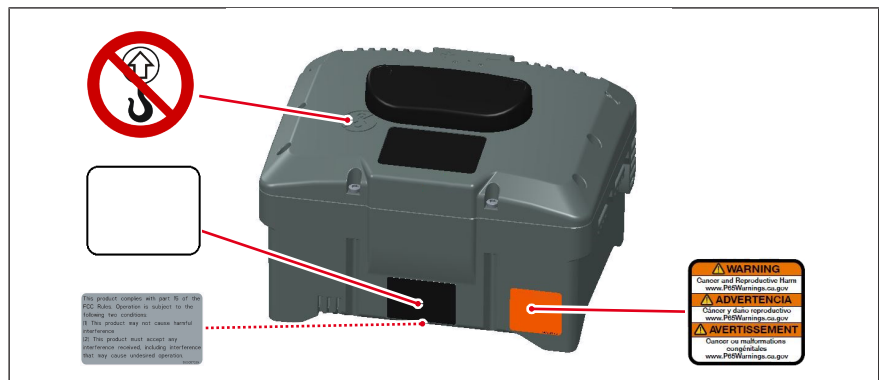

No lifting point.

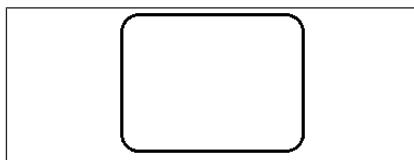

Empty type label.

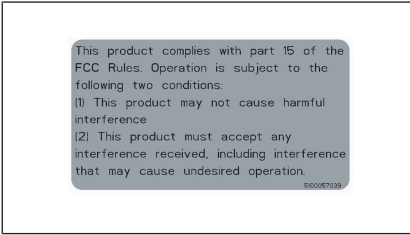

The machine complies with part 15 of the FCC regulations (valid for US market).



Warning of health risks
WARNING! CALIFORNIA: Proposition 65 (Safe Drinking Water and Toxic Enforcement Act of 1986)
For more information: www.P65Warnings.ca.gov

8.3 Safety and information label Battery transport box

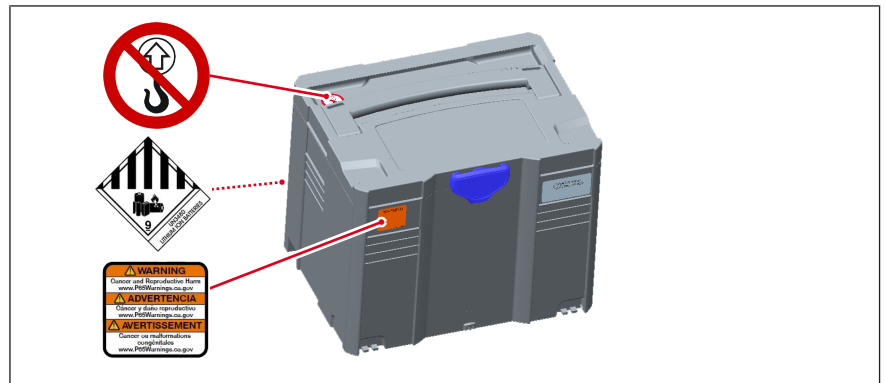

No lifting point.



Dangerous goods class 9A, UN 3480: Lithium-ion batteries.
Observe transport regulations.

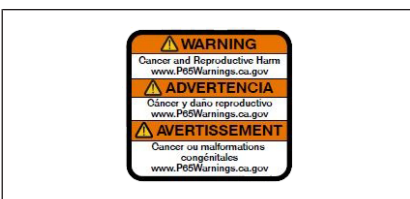

Warning of health risks
WARNING! CALIFORNIA: Proposition 65 (Safe Drinking Water and Toxic Enforcement Act of 1986)
For more information: www.P65Warnings.ca.gov

8.4 Components

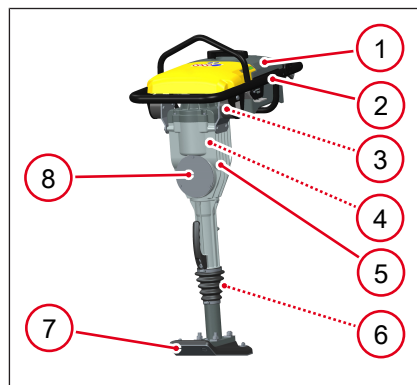

AS30e

- 1 Rechargeable battery
- 2 Guide bracket
- 3 Vibration absorber
- 4 Drive motor
- 5 Crankcase
- 6 Ramming system
- 7 Ramming shoe
- 8 Type label

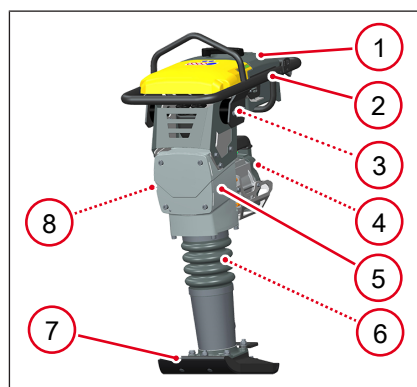

AS50e/AS60e

- 1 Rechargeable battery
- 2 Guide bracket
- 3 Vibration absorber
- 4 Drive motor
- 5 Crankcase
- 6 Ramming system
- 7 Ramming shoe
- 8 Type label

8.5 Control elements

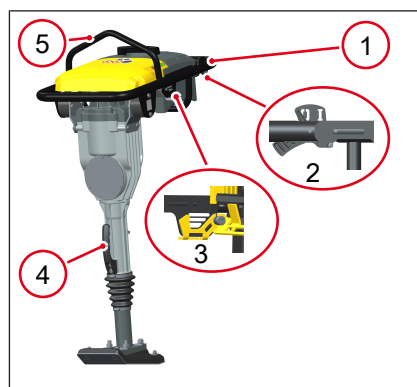

AS30e

- 1 Guide bracket
- 2 Start and safety level
- 3 Lock
- 4 Handle
- 5 Central suspension

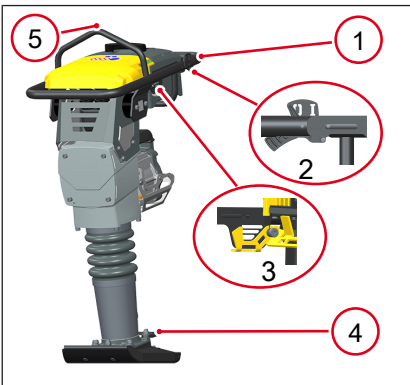

AS50e/AS60e

- 1 Guide bracket
- 2 Start and safety level
- 3 Lock
- 4 Handle
- 5 Central suspension

8.6 Components and control elements accumulator

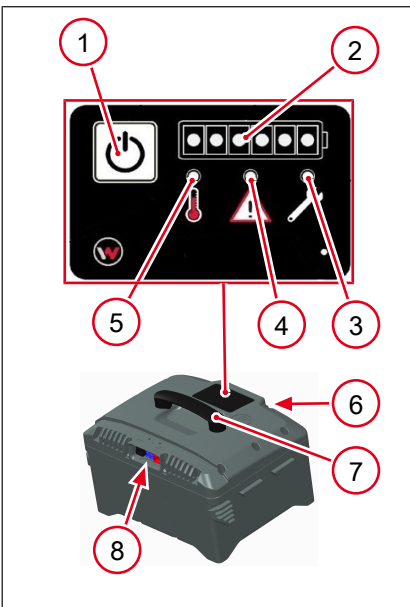

- 1 Start button Activation/deactivation
- 2 Control light Charge condition
- 3 Control light diagnosis
- 4 Control light rechargeable battery error
- 5 Control light overtemperature/undertemperature
- 6 Type label
- 7 Handle
- 8 Connections (contact strip)

Start button Activation/deactivation

The rechargeable battery is activated or deactivated by pressing the start button.

Control light Charge condition

Six LEDs indicate the charge state of the rechargeable battery.

Control light diagnosis

LED comes on. Diagnosis required, contact Wacker Neuson Service.

Control light rechargeable battery error

LED comes on. There is a rechargeable battery error.

Control light overtemperature/undertemperature

LED comes on. The rechargeable battery has reached a temperature that is too high or too low.



8.7 Components and operator's controls battery charger

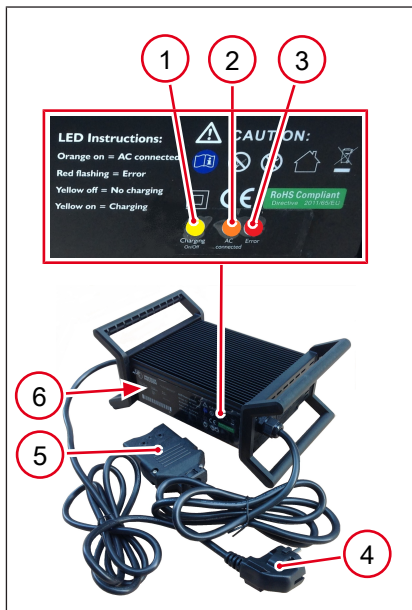

- 1 Control light Charge condition
- 2 Control light Operation
- 3 Control light Fault
- 4 Power cable
- 5 Power cable of the rechargeable battery
- 6 Type label

Control light Charge condition

LED comes on. Rechargeable battery is charged.

Control light Operation

LED comes on. Battery charger is connected to the power supply.

Control light Fault

LED flashes: There is a fault, contact Wacker Neuson Service.

9 Transportation

9.1 Preparations

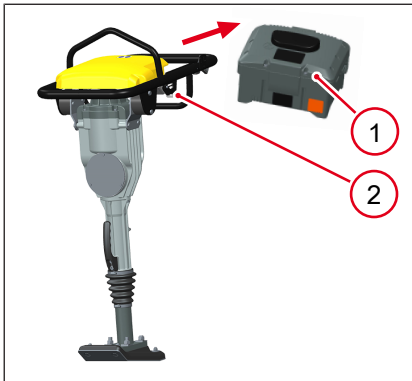

- 1 Rechargeable battery
- 2 Lock

1. Unlock the lock **2** manually.
2. Take the rechargeable battery **1** out of the machine before transport.

9.2 Lifting the machine



NOTICE

- ▶ Designate a competent instructor for a safe lifting procedure.

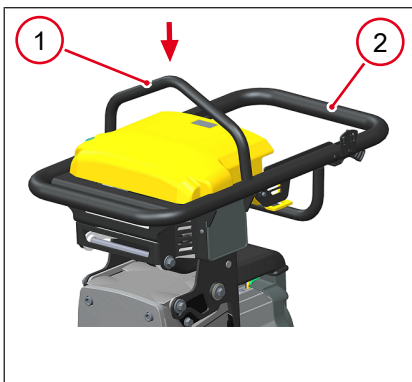

- 1 Central suspension
- 2 Guide bracket

1. Attach suitable sling to central suspension **1** for lifting the machine.
2. Carefully load the machine into or onto a stable and stable means of transport.
3. Move the machine laterally.

9.3 Lashing the machine

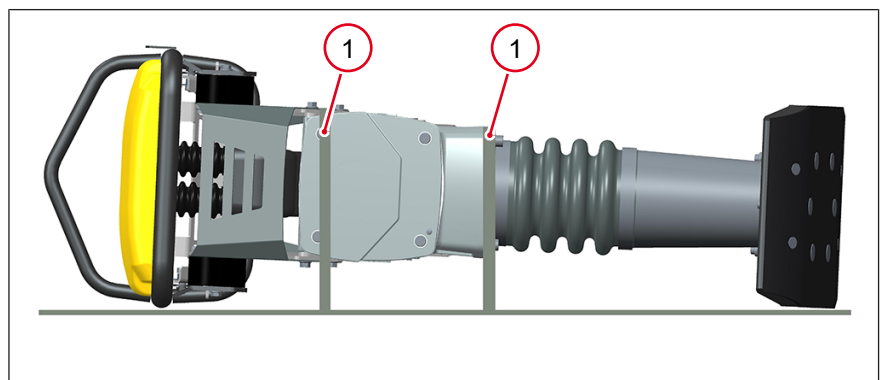



- 1 Attaching tension belts
1. After loading, lash the machine onto the means of transport in such a way that it is secured against rolling, slipping or tipping over.
2. For this purpose, attach the tension belts **1** over the machine and tighten them.

9.4 Packing and transporting rechargeable battery



NOTICE

Material damage due to improper transport!

- ▶ Pack the rechargeable battery safely in the original battery transport box.
 - ▶ Do not remove the cover insert of the battery transport box.
 - ▶ Observe the regulations for the transport of dangerous goods.
-
- Ensure that the rechargeable battery is properly secured and transported.

9.5 Transporting battery charger

1. Roll up the charger's cable.
2. Do not kink the cable.

10 Commissioning

10.1 Tests before commissioning



Information

Further information and detailed descriptions, [see Maintenance on page 45](#).

Perform the following checks:

- Check machine and components for damage.
 - Do not put the damaged machine into operation. Damages and defects must be repaired immediately.
- Check shift lever and safety lever for ease of movement.
- Remove loose packing material from the machine.
- Observe the current regulations of the local authorities regarding noise emissions.
- Check the charge state of the accumulator.
- Check grease or lubricating oil.
- Check to ensure the screw connections are firmly seated.

10.2 Charge the rechargeable battery



NOTICE

Damage to the machine or the accumulator.

Only use chargers and rechargeable batteries from the manufacturer.

Charge the rechargeable battery

1. Place the battery charger and rechargeable battery on a dry and clean working area.
2. Connect the battery charger to the power source.
3. Then connect the rechargeable battery to the battery charger.
4. Check the charge state of battery regularly.
5. If the rechargeable battery is completely charged, unplug the battery from the charger and disconnect the battery charger from the power source.

10.3 Install the rechargeable battery



NOTICE

Damage to the machine or the accumulator.

Connections and contact area of the accumulator must be clean and dry.



NOTICE

Damage to the machine or the accumulator.

Note the direction of installation when installing the accumulator. The connections must point in the direction of the protective cover.

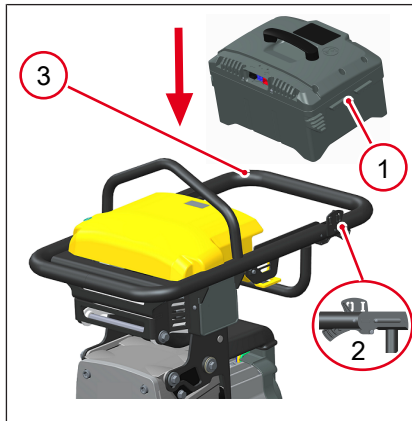

- 1 Rechargeable battery
- 2 Start lever
- 3 Guide bracket

1. Hold the machine with one hand on the guide bracket **3**.
2. Set the machine's start lever **2** to the OFF position.
3. Using the other hand, lift the rechargeable battery by the handle.
4. Carefully insert the rechargeable battery into the provide guide rail.
5. Insert the rechargeable battery by the handle until you hear the lock make a clearly audible click.
6. Make sure the rechargeable battery is firmly seated.

10.4 Safety instructions for operation



⚠ WARNING

CALIFORNIA: Proposition 65 (Law of 1986 on toxic substances and safe drinking water) Warning!

Battery terminals, clamps and similar parts contain lead and lead compounds. These chemicals are considered by the State of California to be the cause of cancer and reproductive harm.

- ▶ Wash hands after working on the battery.



⚠ WARNING

Tipping hazard!

Risk of serious injury from slipping or overturning machine.

- ▶ Ensure sufficient stability.
- ▶ Always secure the machine against tipping over.
- ▶ Park the machine on a level surface with firm ground.



⚠ WARNING

Risk of crushing!

Crushing of hands and feet possible.

- ▶ Work cautiously.



 **CAUTION**

Health hazard due to vibrations!

Physical impairments due to vibration.

- ▶ Take regular breaks.



 **CAUTION**

Risk of injury and material damage due to recoil!

On firm, hard or unyielding floors, injuries and material damage may result from strong rebounds.

- ▶ Avoid hard or unyielding floors.



 **CAUTION**

Risk of collapse and spillage!

There is a risk of injury from falling or spilling when working on fracture, pit, dump and embankment edges, on trench edges and heels.

- ▶ Pay attention to side walls and their stability.
- ▶ Ensure stability.

11 Operation

11.1 Putting into operation

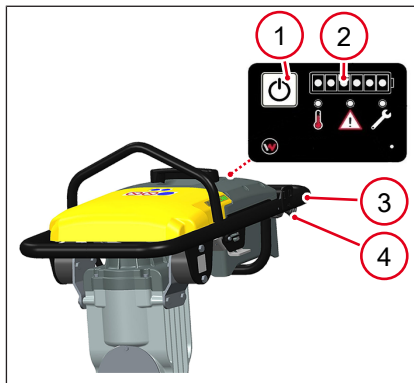

- 1 Start button Actuation/deactivation
- 2 Control light Charge condition
- 3 Guide bracket
- 4 Start lever

✓ Machine stands upright on suitable ground when starting.

1. Set the start lever **4** to the OFF position.
2. Hold the machine by the guide bracket **3**.
3. Press start button activation/deactivation **1**.
4. Check the current state of charge via the control light Charge state **2**.

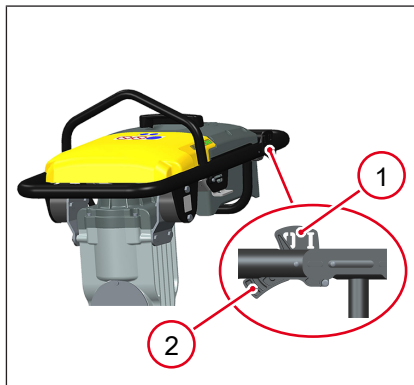

- 1 Start lever
- 2 Safety lever

5. Pull the safety lever **2** with one hand.
6. Slowly press the start lever **1** forward.
⇒ The machine starts up.
⇒ Vibration begins when moved forward.

11.2 Operating the machine

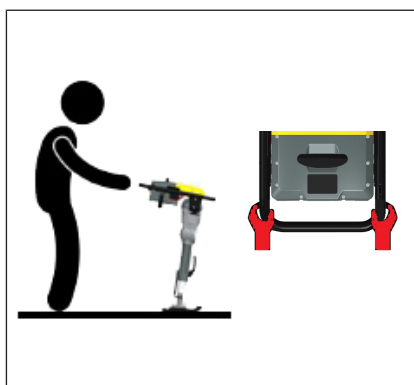

- The operator's designated location is behind the machine.
- Guide and steer the machine using the guide bracket.
- Use the weight of the machine when working.
- Let the machine move forward on its own. Do not use your muscles to push it forward or pull it back.
- For optimal control, performance and minimum hand and arm vibration, hold the guide bracket on the left and right.
- To avoid damage to the machine, do not move the machine when it is running.
- Exercise caution with rough material. To avoid extreme wear and tear to the ramming plate, ensure that it is always parallel to the ground being compacted.

11.3 Check charge state of rechargeable battery

- Check charge condition of rechargeable battery on a regular basis.

Number of illuminated LEDs:	Charge condition of the rechargeable battery
one	charge condition 0 - 20 %
two	charge condition > 20 %
three	charge condition > 40 %
four	charge condition > 60 %
five	charge condition > 80 %
six	rechargeable battery is fully charged.



Information

Automatic shutdown of rechargeable battery!

If not started up, the rechargeable battery automatically switches off after 30 seconds.

11.4 Putting out of operation



⚠ WARNING

Warning of hot surfaces!

Crankcases with engine and guide cylinder can heat up after a short time, which can lead to severe burns if they come into contact with the skin.

- ▶ Always allow the machine to cool down after use.
- ▶ If the cooling phase cannot be maintained (e.g. due to an emergency) - use heat-resistant protective gloves.

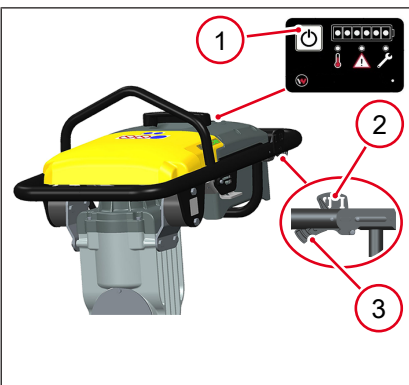

- 1 Start button Activation/deactivation
- 2 Start lever
- 3 Safety lever

1. Slowly pull the start lever **2** back until it stops.
⇒ Safety lever **3** clicks into place with the start lever and holds it in the OFF position.
2. Allow the machine to come to a complete stop.
3. Press start button activation/deactivation **1**.



⚠ CAUTION

Risk of injury from falling machine!

- ▶ Secure the machine against tipping over, falling down or slipping, e.g. in a closed container.

11.5 Remove the rechargeable battery

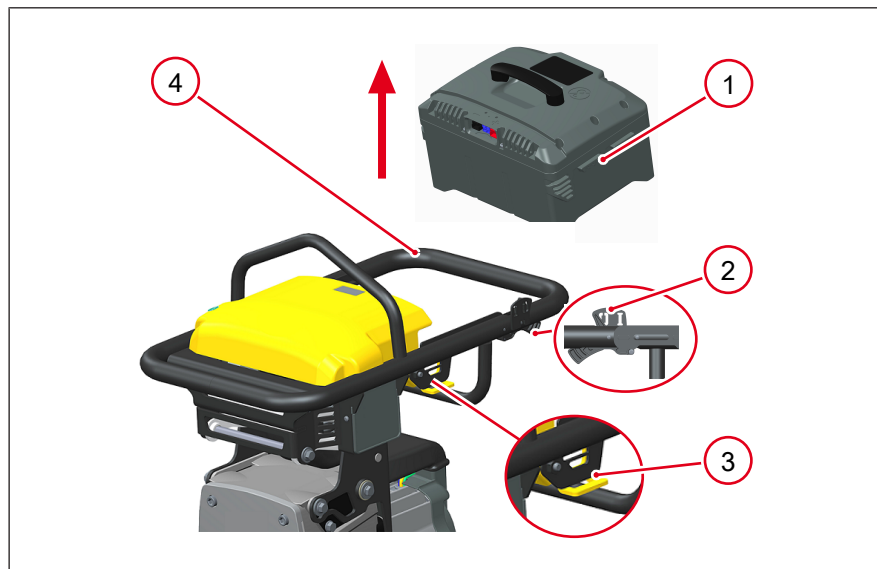

1 Rechargeable battery

2 Start lever

3 Lock

4 Guide bracket

✓ Allow the machine to come to a complete stop.

✓ Start lever **2** is in OFF position.

1. Hold the machine with one hand on the guide bracket **4**.
2. Push the lock **3** down.
3. With the other hand, carefully pull the rechargeable battery **1** by the handle to the rear until it stops.
4. Pull out the rechargeable battery by the handle and put it down safely.

12 Maintenance

12.1 Safety instructions for maintenance



WARNING

Improper handling may result in injury or serious material damage.

- ▶ Please read and follow all safety instructions in this operator's manual.



WARNING

Risk of injury from uncontrolled machine starting and moving parts!

- ▶ Only perform maintenance work when the machine is switched off.
- ▶ Remove the rechargeable battery.



WARNING

Warning of hot surfaces!

Crankcases with engine and guide cylinder can heat up after a short time, which can lead to severe burns if they come into contact with the skin.

- ▶ Always allow the machine to cool down after use.
- ▶ If the cooling phase cannot be maintained (e.g. due to an emergency) - use heat-resistant protective gloves.



WARNING

Danger from electric current.

Risk of injury from electric shock.

- ▶ Switch the machine off.
- ▶ Remove the accumulator.



CAUTION

Health risk from fuel, lubricants and coolants!

- ▶ Do not inhale vapors.
- ▶ Avoid skin and eye contact.



NOTICE

Damage by penetrating water!

Penetrating water can damage electrical operating elements or machine components.

Penetrating moisture can lead to total failure.

- ▶ Do not clean the machine with high pressure or steam cleaners!
- ▶ Use a cloth to remove water that has entered (e.g. due to rain) the housing and then let the machine dry.
- ▶ Only use dry and clean cloths.



Environment

Soil contamination due to oil leaking or overflowing.

- ▶ Line work surface with impermeable foil.
- ▶ Use collecting container for used oil.
- ▶ Dispose of used oil in an environmentally friendly manner in accordance with statutory regulations.

12.2 Maintenance plan

Maintenance work	daily	50 h	300 h
Cleaning: • Machine • Rechargeable battery • Battery charger	•		
Visual check for completeness.	•		
Visual inspection of all components for damage: • Machine • Rechargeable battery • Battery charger	•		
Check shift lever and safety lever for ease of movement and correct function.	•		
Grease ramming system.*		•	
Check oil level and add oil if necessary.**	•		
Oil change**		• ¹	•
Check screw connections.	•		
¹ Change oil for the first time after 50 h. * AS30e ** AS50e / AS60e			

12.3 Maintenance work

12.3.1 Carrying out preparations



CAUTION

Health risk from fuel, lubricants and coolants!

- ▶ Do not inhale vapors.
- ▶ Avoid skin and eye contact.

1. Place the machine on a level surface.
2. Decommissioning the machine.
3. Remove the rechargeable battery.
4. Let the machine cool down.

12.3.2 Cleaning the machine



NOTICE

Damage by penetrating water!

Penetrating water can damage electrical operating elements or machine components.

Penetrating moisture can lead to total failure.

- ▶ Do not clean the machine with high pressure or steam cleaners!
- ▶ Use a cloth to remove water that has entered (e.g. due to rain) the housing and then let the machine dry.
- ▶ Only use dry and clean cloths.



NOTICE

Information on damage to the components!

Contact Wacker Neuson Service if the rechargeable battery or charger is damaged.

1. Clean machine and components after each use.
2. Wacker Neuson recommends using compressed air to clean.
3. Wipe the housing with a damp and clean cloth.
4. Wipe the rechargeable battery and battery charger with a dry clean cloth.
5. After cleaning, check cables and wires for damage.
6. Check screws and bolts to see if they are loose.
7. Remedy any deficiencies noted immediately.

12.3.3 Grease ramming system

AS30e



- 1 Grease nipples
 - ✓ Remove dirt in the area of the grease nipple 1.
1. Place the filled grease gun on the grease nipple and actuate it approx. 20 times (approx. 30 g).
2. Wipe the area of the grease nipple with a clean cloth.

12.3.4 Check oil level and top up



NOTICE

Damage to machine due to incorrect oil level!

A too high oil level can result in a hydraulic lock in the ramming system. This can lead to faulty operation and damage to the ramming system.

- ▶ Do not overfill the ramming system with oil.

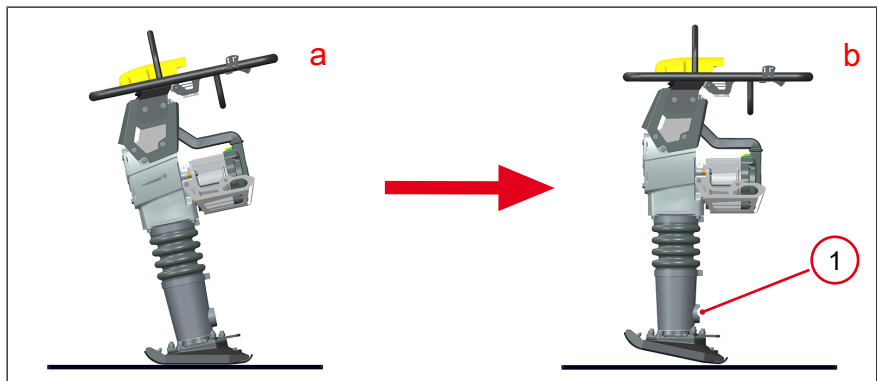

- ✓ After transporting or storing the machine in a horizontal position, it is necessary to let it be in an upright position for at least 15 minutes before checking the oil level.
1. Remove dirt in the area of the oil sight glass 1.
 2. Tilt the machine so that it forms a right angle **b** to the floor.
 3. Check the oil level by using the oil sight glass.
 - ⇒ Oil level must be between $\frac{1}{2}$ and $\frac{3}{4}$.
 4. Add oil if the oil level is low. For oil specifications [see Technical data on page 56](#).

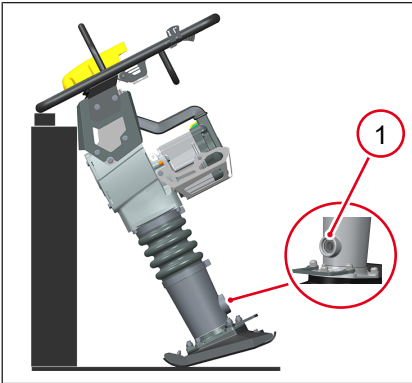

1. Tilt the machine forward to access the oil sight glass 1.
2. Secure the machine in this position.
3. Unscrew the oil sight glass.
4. Clean the threads of the oil sight glass and wrap with Teflon tape.

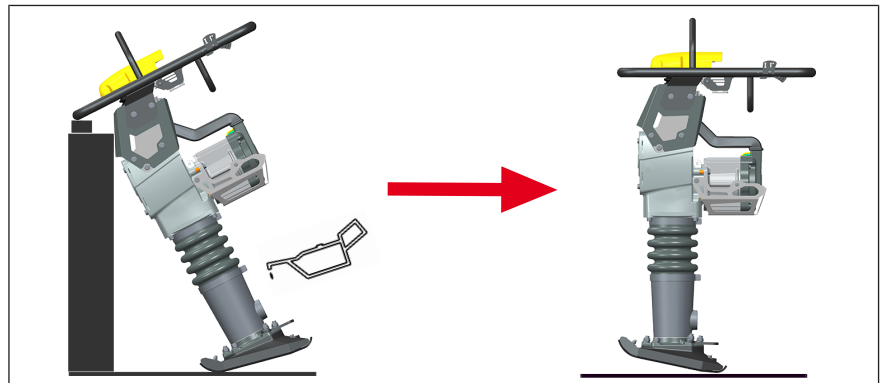

1. Pour oil into the housing through the opening in the oil sight glass.
2. Screw the oil sight glass back on, but do not tighten.
3. Place the machine in upright position to check the oil level.
4. If necessary, top up oil until the oil sight glass $\frac{1}{2}$ to $\frac{3}{4}$ is filled.
5. Tighten the oil sight glass. Tightening torque 9 Nm.
6. Wipe the area of the oil sight glass with a clean cloth.

12.3.5 Changing oil

AS50e / AS60e



Environment

Soil contamination due to oil leaking or overflowing.

- ▶ Line work surface with impermeable foil.
- ▶ Use collecting container for used oil.
- ▶ Dispose of used oil in an environmentally friendly manner in accordance with statutory regulations.

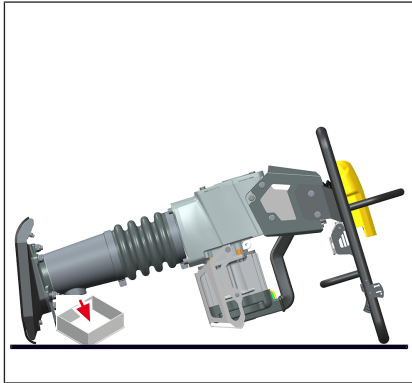

- ✓ Dirt in the area of the oil sight glass has been removed.
1. Unscrew the oil sight glass.
 2. Clean the threads of the oil sight glass and wrap with Teflon tape.
 3. Tilt the machine backwards until it is resting on the guide bracket.
 4. Drain the used oil into a suitable container.



Information

Draining used oil can take up to 10 minutes.

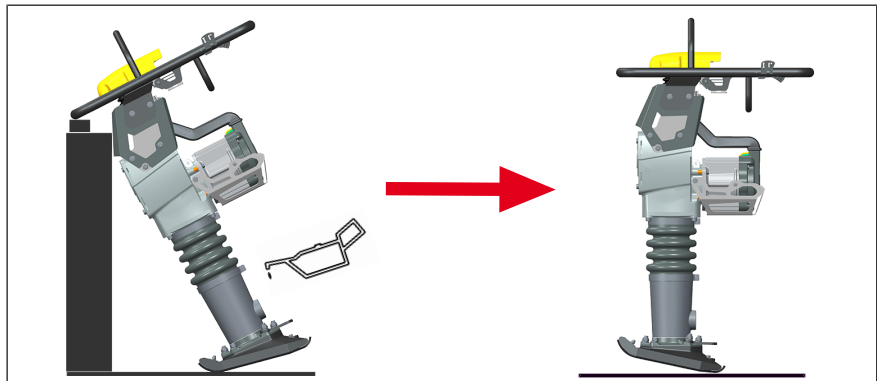

1. Tilt the machine forward and secure it in this position.
2. Pour oil into the housing through the opening in the oil sight glass. Oil specifications [see Technical data on page 56](#).
3. Screw the oil sight glass back on, but do not tighten.
4. Place the machine in upright position to check the oil level.
5. If necessary, top up oil until the oil sight glass $\frac{1}{2}$ to $\frac{3}{4}$ is filled.
6. Then tighten the oil sight glass. Tightening torque 9 Nm.
7. Wipe the area of the oil sight glass with a clean cloth.

13 Malfunctions

13.1 Machine



WARNING

Danger to life due to unauthorized troubleshooting!

- ▶ If faults occur on this machine which are not described in these operating instructions, contact the manufacturer.
- ▶ Do not rectify faults on your own.



Fault	Possible cause	Remedy
The machine will not operate.	The charge state of the rechargeable battery is too low.	Charge the rechargeable battery.
	The rechargeable battery is not properly installed in the machine.	Install the rechargeable battery properly in the machine.
	The rechargeable battery is defective.	Have the rechargeable battery repaired.*
The machine is displaying unexpected faults during commissioning or operation.	Rechargeable battery [▶ 51].	Press start button activation/deactivation and remove the rechargeable, if the fault persists, have the rechargeable battery repaired.*
The machine switches itself off.	The charge state of the rechargeable battery is too low.	Charge the rechargeable battery.
	The machine was overloaded.	Switch the machine on again.
	Machine is overheated.	Let the machine cool down.
	Machine under temperature.	Operate the machine only in the permitted temperature range, [▶ 56].

* Have this work carried out by a service partner.

13.2 Accumulator

Pictogram	Status control light	Possible cause	Remedy
	Control light rechargeable battery error is lit.	Contact error of connection strip.	Clean and if necessary dry the contacts.
		Hardware/software error.	Put the rechargeable battery back into operation and acknowledge the error by pressing the button.
			Have the rechargeable battery repaired.*



Pictogram	Status control light	Possible cause	Remedy
	Overtemperature/undertemperature control light lights up.	Temperature error (too high or too low temperature).	Operate the rechargeable battery only within the permissible temperature range. Allow the equipment to cool down if necessary. Switch the rechargeable battery on again with the start button Activation/deactivation.
	Diagnosis control light lights up.	The rechargeable battery was disabled due to a fault.	Have the rechargeable battery repaired.*

* Have this work carried out by a service partner.

13.3 Battery charger



WARNING

Danger to life due to unauthorized troubleshooting!

- ▶ If faults occur on this machine which are not described in these operating instructions, contact the manufacturer.
- ▶ Do not rectify faults on your own.

Fault	Possible cause	Remedy
The rechargeable battery is not charged.	Connection plug not connected correctly.	Connect connection plug correctly.
	Supply cable not connected to power source.	Plug supply cable into power source.
	The rechargeable battery is defective.	Contact service partner.
	Battery charger is defective.	

14 Shutdown

14.1 Temporary decommissioning



Information

Further information and detailed descriptions, [see Maintenance on page 45](#).

14.1.1 Machine

In order to avoid possible damage, the following points must be observed:

- Always store the machine, rechargeable battery and charger separately.
- Do not store near any flammable materials.
- Do not store outdoors.
- Store dry and free of dust.
- Protect from direct sunlight.
- Protect against freezing temperatures. Observe storage temperature range, [see Technical data on page 56](#).
- Store in a locked place that is not accessible to children.

14.1.2 Accumulator



NOTICE

Property damage due to self-discharge of the accumulator

The self-discharge rate is approx. 3 % per month. Deep discharge can cause damage to the cells or loss of capacity.

- ▶ Store the accumulator with a charge condition of approx. 30 %.
- ▶ Check charge condition every six months.
- ▶ Charge the rechargeable battery.

In order to avoid possible damage, the following points must be observed:

- Do not store near any flammable materials.
- Store at an air humidity of < 80 %. Risk of corrosion!
- Store cool (< 25 °C).
- Store at a charge condition of approx. 30 %.
- Store separately from other hazardous substances (minimum distance of 2.5 meters).
- Do not store with metallic objects. Risk of short circuit!
- Protect from fire, heat and direct sunlight.
- Observe the permissible storage temperatures, [see Technical data on page 56](#).

14.2 Final shutdown

14.2.1 Disposal

The machine contains one or more batteries or accumulators (hereinafter uniformly referred to as "battery"). Professional disposal of the battery avoids negative effects on human health and the environment, helps with the targeted treatment of pollutants and makes it possible to recycle valuable raw materials.

For customers in EU countries

This battery is subject to the European Directive on (old) batteries and (old) accumulators and the relevant national laws. The Battery directive provides the framework for an EU-wide treatment of old batteries.

The battery is marked with the crossed-out garbage bin symbol. Below this symbol there is also the name of the pollutants contained, namely "Pb" for lead, "Cd" for cadmium and "Hg" for mercury.

Batteries must not be disposed of with normal household waste! End users must dispose of used batteries exclusively via the manufacturer and the trade or the collection points specially set up for this purpose (legal obligation to return); the disposal is free of charge. Retailers and manufacturers are obliged to take these batteries back and recycle them properly or dispose of them as hazardous waste (legal obligation to take them back).

Batteries purchased from Wacker Neuson can be returned to Wacker Neuson free of charge after use. If the batteries cannot be returned personally to one of the Wacker Neuson branches, please note any instructions in the purchase contract or in the General Terms and Conditions of the point of sale.

For customers in other countries

Wacker Neuson recommends that the battery be disposed of in an environmentally friendly manner in a separate collection rather than in the normal household waste. National laws or regional regulations may also require batteries to be disposed of separately. Disposal of the battery in accordance with national regulations must therefore be ensured.

15 Accessories

15.1 Transport roller



CAUTION

Risk of injury and possible machine damage!

Using non-original accessories or spare parts can lead to injuries or machine damage.

- ▶ Use only original parts.
- ▶ In case of disregard, no liability will be accepted.



Information

Buy original Wacker Neuson accessories and spare parts online!

Many accessories and spare parts are available for all Wacker Neuson product groups online at www.wackerneuson.com.

15.1.1 Transport roller installation

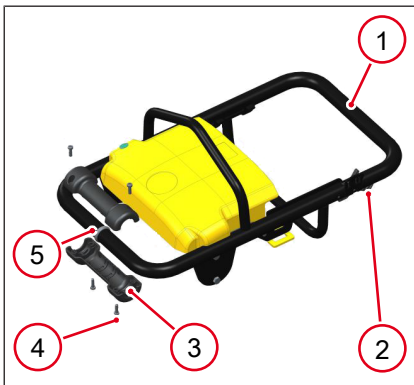

- 1 Guide bracket
- 2 Start lever
- 3 Half shell (transport roller)
- 4 Screw
- 5 Weld

✓ The rechargeable battery is removed.

1. Place the machine horizontally on a flat surface with sufficient load-bearing capacity.
2. Secure machine against overturning.
3. Set the start lever **2** to OFF position.
4. Center the half shells **3** around the weld **5** of the guide bracket **1**.
5. Attach the half shells with four screws **4** to the guide bracket.
6. Tightening torque 2.5 Nm.

16 Technical Data

16.1 General instructions



Information

For system technical reasons, empty columns can be displayed in the technical data, and numbers and letters that written in superscript or subscript may be displayed incorrectly, e.g:

- ▶ Sound power level LWA instead of L_{WA}
- ▶ Sound pressure level LpA instead of L_{pA}
- ▶ Vibration total value ahv instead of a_{hv}
- ▶ Carbon dioxide CO₂ instead of CO₂
- ▶ Unit m/s² instead of m/s²

16.2 Noise and vibration data

The noise and vibration data listed have been determined in accordance with the following guidelines for the typical machine operating conditions / special test conditions and using harmonized standards:

- Machinery Directive 2006/42/EC
- Noise Emission Directive 2000/14/EC

During operational use, values may differ depending on the prevailing operating conditions.

Sound pressure level at operator station

- L_{pA} was determined according to EN ISO 11201 and EN 500-4.

Guaranteed sound power level

- L_{WA} was determined according to EN ISO 3744 and EN ISO -4.

Weighted vibration total value hand-arm vibration

- a_{hv} was determined according to EN ISO 20643 and EN 500-4.

16.3 Machine

Type	AS30e	AS50e
Material number	5100026851	5100053792
Rated current [A]	26,30	41,00
Rated voltage [V]	51	51
Rated output [kW]	1,34	2,10
Type of current (output)	Direct current (DC)	Direct current (DC)
Number of strokes [1/min]	810	680
Forward travel [m/min]	11,00	11,40
Impact force [kN]	10	16
Length [mm]	620	610

Type	AS30e	AS50e
Width [mm]	361	363
Height [mm]	1.046	1.050
Length (Ramming shoe) [mm]	296	340
Width (Ramming shoe) [mm]	150	280
Operating weight [kg]	41,7	71
Lift at ramming shoe [mm]	40	44
Engine type	Asynchronous engine	Asynchronmotor
Insulation class	F	F
Rated output [kW]	1,300	1,950
Rated torque [Nm]	2,100	3,300
Rated speed [1/min]	4.700	4.350
Recommended battery type	BP1000; BP1400	BP1000; BP1400
Special lubricants	Gadus S3 V220C 2	SAE 10W30
Relubrication interval [h]	50	250
Oil specifications (Ramming system)	–	SAE 10W40
Oil volume (Ramming system) [l]	–	0,700
Protection type	IP23	IP23D
Operating temperature range [°C]	0 – +45	0 – +45
Storage temperature range [°C]	-30 – +50	-30 – +50
Sound pressure level LpA [dB(A)]	87	91
Sound power level LWa measured [dB(A)]	103	102
Sound power level LWa guaranteed [dB(A)]	108	108
Vibration total value ahv [m/s ²]	7,5	7,1
Measurement uncertainty of the total vibration value ahv [m/s ²]	1,0	2,2

* The actual operating speed depends on numerous operating parameters and may differ from the rated speed.

Type	AS60e	
Material number	5100052267	
Rated current [A]	44,00	
Rated voltage [V]	51	
Rated output [kW]	2,24	
Type of current (output)	Direct current (DC)	
Number of strokes [1/min]	680	
Forward travel [m/min]	12,1	
Impact force [kN]	17	
Length [mm]	610	
Width [mm]	363	
Height [mm]	1.050	
Length (Ramming shoe) [mm]	340	
Width (Ramming shoe) [mm]	280	
Operating weight [kg]	71	
Lift at ramming shoe [mm]	61	



Type	AS60e	
Engine type	Asynchronous engine	
Insulation class	F	
Rated output [kW]	2,120	
Rated torque [Nm]	3,500	
Rated speed [1/min]	4.350	
Recommended battery type	BP1000; BP1400	
Special lubricants	SAE 10W30	
Relubrication interval [h]	250	
Oil specifications (Ramming system)	SAE 10W40	
Oil volume (Ramming system) [l]	0,700	
Protection type	IP23D	
Operating temperature range [°C]	0 – +45	
Storage temperature range [°C]	-30 – +50	
Sound pressure level LpA [dB(A)]	92	
Sound power level LWA measured [dB(A)]	105	
Sound power level LWA guaranteed [dB(A)]	108	
Vibration total value ahv [m/s ²]	8,3	
Measurement uncertainty of the total vibration value ahv [m/s ²]	2,2	

* The actual operating speed depends on numerous operating parameters and may differ from the rated speed.

16.4 Rechargeable battery

Type	BP1000	BP1400
Material number	5100025709	5100048620
Rated voltage [V]	51	51
Type of current (output)	Direct current (DC)	Direct current (DC)
Length [mm]	220	220
Width [mm]	290	290
Height [mm]	197	197
Weight [kg]	9,4	9,6
Range per battery charge [m] AS30e	572	770
Range per battery charge [m] AS50e	342	456
Range per battery charge [m] AS60e	278	363
Battery label	14INR19/65-8	14INR19/65-8
Battery type	Lithium-Ionen	Lithium-Ionen
Energy content [Wh]	1.008	1.411
Capacity [Ah]	20	28
Discharge current max. [A]	160	80
Charge current max. [A]	32	27
Protection type	IP2X	IP2X
Storage temperature range [°C]	-30 – +50	-30 – +50
Operating temperature range [°C]	-10 – +50	-10 – +50

Type	BP1000	BP1400
Operating temperature range charging [°C]	0 – +45	0 – +45

16.5 Battery charger

Type	C48/4	
Material number	5100006221	
Rated voltage [V]	230 (90 – 265)	
Type of current (input)	Alternating current 1~	
Rated current [A]	<3	
Rated frequency [Hz]	50 – 60	
Type of current (output)	DC	
Output current [A]	4 +/-0,5	
Output voltage max. [V]	57,6	
Length [mm]	190	
Width [mm]	145	
Height [mm]	65	
Weight [kg]	2,0	
Power cable [mm]	1500	
Supply cable [mm]	1800	
Protection class	II	
Protection type	IP54	
Storage temperature range [°C]	-30 - +50	
Operating temperature range [°C]	0 - +45	

16.6 Extension cable

- Only use permissible extension cables, .
- Data on the type designation and voltage of this machine can be found on the type label.
- Refer to the following table for the required wire cross-section of the extension cable:

Type	C48/4	
Material number	5100006221	
Extension [m]	≤150	
Strand cross section [mm ²]	1,5	

16.7 Conversion table

The following conversion tables enable the conversion of the metric values from the instructions, in particular the technical data, into the imperial.

Conversion table
Volume units



Conversion table	
1 cm ³	0.061 in ³
1 m ³	35.31 ft ³
1 ml	0.034 US fl.oz.
1 l	0.26 gal.
1 l/min	0.26 gal./min
Length units	
1 mm	0.039 in
1 m	3.28 ft
Weights	
1 kg	2.2 lbs.
1 g	0.035 oz.
Pressure	
1 bar	14.5 psi
1 kg/cm ²	14.22 lbs/in ²
Force/output	
1 kN	224.81 lbf
1 kW	1.34 hp
1 PS	0.986 hp
Torque	
1 Nm	0.74 ft.lbs
Speed	
1 km/h	0.62 mph
Acceleration	
1 m/s ²	3.28 ft./s ²



**WACKER
NEUSON**
all it takes!

**Wacker Neuson Produktion GmbH &
Co. KG**

Wackerstraße 6
D-85084 Reichertshofen

Tel.: +49 8453 340-0
EMail: service-LE@wackerneuson.com
www.wackerneuson.com

Material number: 5100056974

Language: [us]