



# Mapelastic™ WaterStop

## Waterproofing and Crack-Isolation Membrane



### DESCRIPTION

*Mapelastic WaterStop* is a flexible, thin, fast-drying, one-component, liquid-rubber waterproofing and crack-isolation membrane for installation under ceramic tile or stone in residential, commercial and industrial environments. It provides a continuous barrier to protect adjacent floors and rooms below from water damage. *Mapelastic WaterStop* also prevents in-plane floor cracks (up to 1/8" [3 mm]) from transmitting through tile or stone. In problem areas such as coves, corners, cracks and drains, it can be combined with MAPEI's optional *Reinforcing Fabric* or *Mapeband™* accessories (cove roll and drain flashing) to provide additional protection.

### FEATURES AND BENEFITS

- Fast-drying: Install tile after 60 to 90 minutes of drying time.
- Flood-test as a shower-pan liner after 12 hours of drying time.
- Easy to apply with roller or brush; water cleanup
- Bonds to a wide range of surfaces; convenient, user-friendly and versatile
- No odor; great for confined spaces
- Prevents in-plane floor cracks from transmitting through tile or stone

### INDUSTRY STANDARDS AND APPROVALS

- ANSI: Exceeds A118.10 standard (Waterproofing Membranes for Thin-Set Ceramic Tile) and A118.12 standard (Crack-Isolation Membranes for Thin-Set Ceramic Tile)
- ASTM: C627 (Robinson) service rating for extra heavy
- IAPMO (File #3996): Listed for use as shower-pan liner
- ICC Evaluation Service Report ESR 3474

### WHERE TO USE

- Residential and commercial interior/exterior floors, walls and ceilings
- Industrial interior floors and walls
- Bathroom tub and shower surrounds
- Kitchens: food prep, dishwashing, servery and cafeteria areas
- Countertops and laundry rooms
- Residential and commercial submerged applications: freshwater pools, fountains and water features (must be covered by ceramic tile)
- Cantilevered balconies and decks over unoccupied space (see the "Limitations" section)
- Balconies and decks over occupied space when used in conjunction with a primary waterproofing membrane
- Steam rooms when used in conjunction with a vapor barrier (refer to the TCNA Handbook's sections SR613 and SR614 or TTMAC 321SR).
- In-plane crack isolation up to 1/8" (3 mm) over nonstructural cracks
- MAPEI's *Reinforcing Fabric* is available but optional for use on coves, corners and field application.

### LIMITATIONS

- *Mapelastic WaterStop* is not for use over structural cracks, in-plane cracks beyond 1/8" (3 mm) or where vertical out-of-plane movement occurs.
- Do not use over substrates containing asbestos, dimensionally unstable substrates such as hardwood flooring, particleboard, oriented strand board (OSB), Masonite or metal. See the "Suitable Substrates" section below.



- Do not use over plank flooring, treated plywood, Luan, gypsum-based floor-patching compounds, vinyl, glazed tile, laminate, fiberglass or epoxy floors, or storage tanks.
- Do not use where excessive substrate moisture and/or where negative hydrostatic pressure exists. Maximum allowable moisture is 5 lbs. per 1,000 sq. ft. (2,27 kg per 92,9 m<sup>2</sup>) per 24 hours per ASTM F1869 or up to 85% relative humidity as measured with moisture probes.
- Do not use as a single-application roof-deck membrane, wear surface or primary waterproofing membrane on balconies or decks directly over occupied space or in storage tanks; or with premixed setting materials.
- Do not allow direct contact with solvent-based materials.

Consult MAPEI's Technical Services Department for installation recommendations regarding substrates and conditions not listed.

## SUITABLE SUBSTRATES

### Interior and exterior

- Fully cured concrete at least 28 days old and free of moisture problems
- Masonry walls of cement block or brick
- Cured cement mortar beds or leveling coats
- Cement backer units (CBUs)

### Interior only

- Gypsum wallboard (walls only, in approved application areas only)
- Properly prepared radiant-heated substrates
- Properly prepared unglazed ceramic tile and cement terrazzo floors, and gypsum underlaments with at least 2,500 psi (17,2 MPa) in compressive strength

Note: Existing unglazed ceramic tile must be abraded, and existing cement terrazzo must be mechanically profiled. Both must be skimcoated with an appropriate MAPEI latex- or polymer-modified mortar.

- Exterior-grade plywood (for interior residential floors and countertops in dry areas only)
- PVC, copper, brass and stainless-steel pipe penetrations (abraded by sandpaper)

---

### **Tile Council of North America (TCNA) Statement on Deflection Criteria**

Floor systems, including the framing system and subfloor panels, over which tile will be installed should be in conformance with the IRC [International Residential Code] for residential applications, the IBC [International Building Code] for commercial applications, or applicable building codes.

Note: The owner should communicate in writing to the project design professional and general contractor the "intended use" of the tile installation, in order to enable the project design professional and general contractor to make necessary allowances for the expected live load, concentrated loads, impact loads, and dead loads including the weight of the tile and setting bed. The tile installer shall not be responsible for any floor framing or subfloor installation not compliant with applicable building codes, unless the tile installer or tile contractor designs and installs the floor framing or subfloor.

---

## SURFACE PREPARATION

Before beginning, see MAPEI's "Surface Preparation Requirements" document in the Product Information section of the Tile & Stone Installation Systems page on MAPEI's Website.

- All recommended substrates must be structurally sound, stable, clean and free of any substance preventing adhesion.
- Do not use chemicals (acid etching or stripping) to prepare approved substrates.
- Concrete substrates should have a concrete surface profile (CSP) of #2 per the International Concrete Repair Institute (ICRI). Mechanically clean and profile by diamond-cup grinding or other engineer-approved method when necessary.
- Substrate and room temperatures must be 45°F to 95°F (7°C to 35°C) during and at least 24 hours after application.

## MIXING

Choose all appropriate safety equipment before use. Refer to the Safety Data Sheet for details.

1. Mix by hand before using.
2. Do not dilute with any other material.
3. Promptly wash tools with water after mixing.

## PRODUCT APPLICATION

Read all installation instructions thoroughly before installation.

- Fill all cracks, control joints and gaps in corners and coves that are greater than 1/32" (1 mm) with an appropriate filler material. Force material into each crack and finish smooth with a trowel. Let it dry.
- MAPEI's optional *Reinforcing Fabric* may be used with *Mapelastic WaterStop* in any of the areas shown below (see the section "Optional Use of MAPEI's *Reinforcing Fabric*.")
- MAPEI's *Mapeband* accessories (cove roll and drain flashing) also may be used with *Mapelastic WaterStop* in any of the areas shown below (see the section "Optional Use of *Mapeband Accessories*").

#### Pre-treat cracks, corners and coves (floor/wall intersections)

1. For expansion and control joints, see the section "Expansion and Control Joints."
2. Apply 6" (15 cm) of *Mapelastc WaterStop* liquid on both sides of cracks, corners and coves with a paintbrush or roller. Let it dry to a dark red color.
3. Apply a second coat and let it dry.

#### Pre-treat drains

1. Review the drain manufacturer's instructions for waterproof membrane installation in conjunction with these *Mapelastc WaterStop* instructions.
2. Fill the space between the drain pipe and substrate with appropriate expansion joint materials (typically foam backer rod and sealant).
3. For drains with a bolt-down collar and weep holes, loosen and remove bolts from the drain flange. Abrade the drain flange with sandpaper, and clean and dry thoroughly.
4. With a paintbrush, apply a liberal coat over and around the drain flange. Let it dry to a dark red color.
5. Apply a second coat and let it dry.

#### Pre-treat openings around pipes and other penetrations

1. Pack/fill the openings/spaces between the drain pipe and substrate with appropriate expansion joint materials (typically a foam backer rod and sealant).
2. Apply *Mapelastc WaterStop* with a brush around and up onto the floor or wall penetration. Let it dry to a dark red color.
3. Apply a second coat and let it dry.

#### Complete the main area

1. Apply *Mapelastc WaterStop* to the entire area to be waterproofed (including previously coated areas such as cracks, drains and penetrations) using a 1/2" (12 mm) nap roller. Let it dry to a dark red color.
2. Apply a second coat to the entire installation. Let it dry for 60 to 90 minutes before installing tile or stone.
3. The final dry thickness of first and second coats combined in the main area should be at least 25 to 30 mils.
4. Inspect and, as needed, recoat pinholes or areas not completely covered. Let it dry.
5. Apply a bead of silicone or urethane sealant around the drain flange at the drain throat to join *Mapelastc WaterStop* to the drain assembly. Leave no voids.
6. Bolt down the collar to the drain flange.
7. Where the *Mapelastc WaterStop* coating ends on any penetration, apply a bead of silicone or urethane sealant.

### **CLEANUP**

- Remove excess *Mapelastc WaterStop* (while fresh) with a damp sponge, soap and warm water. Any completely dried material can be mechanically removed.

### **PROTECTION**

- Protect the application from foot traffic, rain and freezing for 24 hours.
- Protect the installed *Mapelastc WaterStop* from contamination, excessive heat and extended sun exposure until tile or stone is installed.

### **FLOOD-TESTING (per ASTM D5957)**

If flood-testing is required, allow *Mapelastc WaterStop* to cure for at least 12 hours at 73°F (23°C) and 50% relative humidity. Actual curing time depends on air and substrate temperatures, substrate porosity and humidity. Expect shorter drying times in warmer conditions, and longer drying times in cooler conditions.

### **INSTALLING CERAMIC TILE OR NATURAL STONE**

- *Mapelastc WaterStop* is ready to receive thin-set mortars for tile or stone when dry to touch (about 60 to 90 minutes after applying second coat).
- Let *Mapelastc WaterStop* cure for at least 8 hours before installing medium-bed mortars (for large tile or stone), screeds (for leveling floors) or epoxy adhesives.
- For tile and stone installations, use a MAPEI polymer-modified mortar meeting ANSI A118.4, ANSI A118.11 or ANSI A118.15, or an epoxy mortar meeting ANSI A118.3. For sheet vinyl or wood-flooring installations, use an appropriate epoxy or urethane adhesive.

### **EXPANSION AND CONTROL JOINTS**

#### **Installation with Mapeband:**

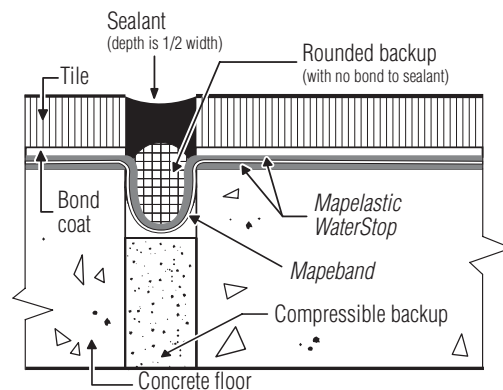

#### **Installation with MAPEI's Reinforcing Fabric:**

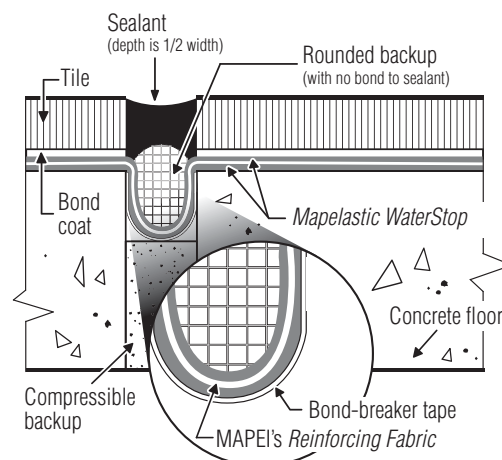

1. Do not cover any substrate expansion or control joints with mortar or tile. Provide where specified per TCNA Detail EJ-171 or TTMAC Detail 301MJ.
2. If waterproofing integrity is required in expansion and control joints, provide per the drawings above. MAPEI's *Reinforcing Fabric* or *Mapeband* can be embedded into the *Mapelastick WaterStop* liquid, allowed to dry and filled with appropriate joint sealant or an expansion molding system.
3. Protect tilework with metal strips (edge metal) along both edges of structural building expansion joints.

Contact MAPEI's Technical Services Department for more information.

### **OPTIONAL USE OF MAPEI'S REINFORCING FABRIC**

Select a fabric size (see packaging chart)

- For coves (floor/wall intersections), allow for 2" (5 cm) of fabric on the floor and 4" (10 cm) up the wall. For cracks, control joints and vertical corners, allow for 3" (7,5 cm) of fabric on each side.
- For drains, cut the desired fabric size from the 38" (97-cm) wide roll. For floor or wall penetrations, use 6" (15-cm) wide, 38" (97-cm) wide or a combination of both.
- For large areas, the 38" (97-cm) wide roll is recommended.

Cut the fabric to size

Cut all required pieces and set them aside.

Pre-treat cracks, control joints, corners, coves, drains and floor/wall penetrations

1. Apply *Mapelastick WaterStop* as described in the "Pre-treat" sections above.
2. Lay pre-cut pieces of fabric into wet *Mapelastick WaterStop*. Use a brush to press fabric into corners until liquid comes through the fabric. Work out any wrinkles or bubbles.
3. While the fabric is wet, apply additional *Mapelastick WaterStop* over the fabric until it is completely covered to create void-free surface. Let it dry to a dark red color.
4. Apply a second coat and let it dry.

Install fabric on the main area

1. Apply the first coat of *Mapelastick WaterStop* (including areas previously coated) using a 1/2" (12-mm) nap roller.
2. Place fabric into wet liquid on the floor. Using a roller, apply pressure to the fabric, working out wrinkles or bubbles while forcing *Mapelastick WaterStop* to come through the fabric. Overlap the seams and ends of fabric by 2" (5 cm). While the fabric is still wet, apply additional *Mapelastick WaterStop* over it until it is completely covered, creating a void-free surface. Let it dry completely to a dark red color.

3. Apply a second coat of *Mapelastick WaterStop* to the entire area. Let it dry.
4. Give a final inspection to the application, looking for pinholes, areas not completely covered and other defects.
5. Recoat as needed and let it dry to a dark red color.
6. Apply a bead of commercial-grade silicone or urethane sealant between the membrane and the drain flange, about 1/2" (12 mm) in from the drain opening.
7. Bolt the drain collar into place while the sealant is still fresh.
8. Install ceramic tile or natural stone per the above section "Installing Ceramic Tile or Natural Stone."

### **OPTIONAL USE OF MAPEBAND ACCESSORIES**

1. MAPEI's *Mapeband* accessories (cove roll and drain flashing) are waterproof, vapor-proof thin, elastic, deformable, rubber-coated fabric pieces that are fully compatible with *Mapelastick WaterStop* and provide the ultimate in "change-of-plane" waterproofing protection for coves, corners and drains. *Mapeband* accessories are ideal for environments requiring waterproofing but also where temperature extremes, freeze/thaw conditions, vibrations, etc., can cause waterproofing problems.
2. *Mapeband* cove roll can be used in place of MAPEI's *Reinforcing Fabric* on coves, corners and control joints. The "felt side" should face into the corner.
3. *Mapeband* drain flashing can be used in place of MAPEI's *Reinforcing Fabric* on drains. The "felt side" should face down.
4. See *Mapeband*'s Technical Data Sheet for installation details.

## Product Performance Properties

Laboratory Tests	Results
pH	9
Viscosity	Approximately 30,000 cps
Density	1,3 g per mL
Weight	10.9 lbs. per U.S. gal. (1,3 kg per L)

## Shelf Life and Application Properties

Shelf life	2 years when stored in original, unopened container
Flash point (Seta flash)	Nonflammable
Color	Medium red when wet; dark red when dry
Drying time between first and second coats	About 20 to 30 minutes (when dark red and dry to the touch)
Drying time after second coat (before applying ceramic tile or stone)	Total drying time for two coats about 60 to 90 minutes (when second coat is dark red and dry to the touch)
Drying time before flood-testing	After 12 hours at 73°F (23°C) and 50% relative humidity
Final dry thickness (2 coats)	25 to 30 mils minimum
Freeze/thaw stability (liquid)	Up to 5 cycles at 32°F (0°C)
Storage	Store in cool, dry place. Protect from freezing.

## Packaging (*Mapelastic WaterStop*)

Size	Approximate Coverage (per 2 coats)*
Pail: 3.5 U.S. gals. (13,2 L)	175 sq. ft. (16,3 m <sup>2</sup> )

\* Coverage shown is for estimating purposes only. Actual jobsite coverage may vary according to substrate conditions, concrete profile and porosity, type of equipment used, thickness applied, handling and application procedures.

## Packaging (optional *Reinforcing Fabric*)

Size	Approximate Coverage
Roll: 6" x 75 ft. (15 cm x 22,9 m), 8 per box – To reinforce over cracks, control joints, corners, coves and floor/wall penetrations	37.5 sq. ft. (3,48 m <sup>2</sup> ) per roll
Roll: 38" x 75 ft. (97 cm x 22,9 m), 1 per box – To reinforce around drains or the main area to be waterproofed	237.5 sq. ft. (22,1 m <sup>2</sup> ) per roll

## Packaging (*Mapeband* waterproofing accessories)

Size and Color
Drain flashing (blue): 16.75" x 16.75" (42,5 x 42,5 cm)
Cove roll (blue): 4.75" x 163 ft. (12 cm x 49,7 m)

## RELATED DOCUMENTS

Reference Guide: Surface Preparation Requirements for tile and stone installation systems	RG0309*
-------------------------------------------------------------------------------------------	---------

\* At [www.mapei.com](http://www.mapei.com)

Refer to the SDS for specific data related to VOCs, health and safety, and handling of product.

## STATEMENT OF RESPONSIBILITY

Before using, user shall determine the suitability of the product for its intended use and user alone assumes all risks and liability whatsoever in connection therewith. **ANY CLAIM SHALL BE DEEMED WAIVED UNLESS MADE IN WRITING TO US WITHIN FIFTEEN (15) DAYS FROM DATE IT WAS, OR REASONABLY SHOULD HAVE BEEN, DISCOVERED.**

We proudly support the following industry organizations:



**MAPEI Headquarters of the Americas**  
 1144 East Newport Center Drive  
 Deerfield Beach, Florida 33442  
 1-888-US-MAPEI (1-888-876-2734) /  
 (954) 246-8888

**Technical Services**  
 1-800-992-6273 (U.S. and Puerto Rico)  
 1-800-361-9309 (Canada)  
**Customer Service**  
 1-800-42-MAPEI (1-800-426-2734)

**Services in Mexico**  
 0-1-800-MX-MAPEI (0-1-800-696-2734)  
**Edition Date:** February 27, 2015  
 MKT: 14-1372