



Concrete Vibrator

Backpack Model WBP50



CONTENTS

Safety	5
Benefits of Vibration.	5
Head and Shaft Selection	5
Adjusting the Backpack	6
Frame	6
Hip Belt	6
Shoulder Straps.	6
Load Lifters	6
Sternum Strap.	6
Final Tweaks	6
Pre-Operation Checks	7
Is Your Engine Ready to Go?	7
Operation	7
Safe Operating Precautions	7
Starting the Engine	7
Setting the Engine Speed	8
Stopping the Engine	9
Maintenance	9
Flex Shaft Grease.	9
Vibrator Head Lubricant	9
Speed Increaser Servicing	9
Honda Engine GXH50.	10
Servicing the Engine	10
The Importance of Maintenance	10
Maintenance Safety	10
Safety Precautions.	10
Maintenance Schedule	11
Refueling	11
Engine Oil	12
Air Cleaner	13
Spark Plug	13
Spark Arrester (Optional Equipment)	14
Storing Your Engine	14

Troubleshooting	16
Service	16
Parts.	16
Honda Engine Parts	16
Honda Engine Warranty	16
Wyco Warranty	16
Wyco Drawings.	16
W402558 Backpack Assembly.	17
W402536 Frame Assembly.	18
W402552 Speed Increaser Assembly	19

SAFETY

Read and follow all safety precautions given in the Honda engine instruction manual for their GXH50 engine. Read and follow the safety instructions given below.

⚠ DANGER

- **WHEN THE BACKPACK IS WORN, THE FLEX SHAFT MUST ALWAYS BE ON THE RIGHT HAND SIDE OF THE OPERATOR AS ASSEMBLED BY THE FACTORY. IF USED ON THE LEFT SIDE, THE MUFFLER EXHAUST WOULD BE DIRECTED TOWARD THE OPERATOR'S BACK, CREATING A DANGEROUS SITUATION.**
- **NEVER FILL THE ENGINE WITH GAS WHILE THE BACKPACK IS ON OPERATOR'S BACK OR WHILE IT IS RUNNING! IF FUEL IS SPILLED, WIPE IT AWAY CAREFULLY, AND WAIT UNTIL THE FUEL HAS DRIED BEFORE STARTING THE ENGINE.**
- **FLAMMABLE, NO SMOKING.**
- **NEVER RUN THE ENGINE WITHOUT THE FLEX SHAFT ATTACHED. WITH THE FLEX SHAFT REMOVED, THE ROTATING SHAFT IS EXPOSED, WHICH COULD GET ENTANGLED WITH LOOSE CLOTHING, HANDS AND OTHER ITEMS, CAUSING A DANGEROUS SITUATION.**

⚠ WARNING

- **ALWAYS WEAR HEARING AND EYE PROTECTION.**
- **KEEP HANDS AWAY FROM HOT METAL PARTS OF THE ENGINE AND SPEED INCREASER.**

⚠ CAUTION

DO NOT OPERATE THE UNIT ABOVE SPEEDS LISTED IN "OPERATION" ON PAGE 7. EXCESSIVE SPEEDS WILL DAMAGE THE ENGINE AND VIBRATOR HEAD AND IT WILL VOID ANY WARRANTY.

BENEFITS OF VIBRATION

Why use Wyco products to vibrate?

- Increased concrete strength by removing air voids.
- Improved appearance by removing air voids.
- Increased bond between concrete and reinforcing bars.
- Fluidized concrete allows a stiffer mix with a lower water to cement ratio to be placed. This increases concrete strength.
- Reduced cold joints and honey combing.

HEAD AND SHAFT SELECTION

The WBP50 uses a quick disconnect (Q.D.). The Q.D. connect lets you push the flex shaft assembly into the motor connector, rotate it 1/4 turn, then use a lever mechanism to lock it in place.

If using a Wyco shaft with a threaded end, threaded male connector part number W423500 is required.

Shaft	Head
CK-8900	750-D (13/16" square)
	750-EH (1" square)
CK-9500	750-FI (1-3/8" square)
	750-GI (1-3/4" square)
	750-LI (2" square) recommended
	750-SBI (2" round short)

LI is the largest sized head and is recommended with this unit.

Although a standard 14-foot shaft length is available for all head sizes, the length may be cumbersome to handle. The *recommended* shaft lengths are 7 and 10 feet. Heavy duty flex shafts—available for the 1-3/8" and larger head sizes only—are available in the two most common lengths, 7 ft (part number W989509) and 10 ft (part number W989512). These shafts have reinforcing springs that increase life in this application.

Use the head size that best matches the application. Consider the vibrator's radius of action when selecting a vibrator head, ensuring that the entire area of concrete is vibrated. A vibrator's radius of action is approximately 4 times the head size (head sizes are listed in the table above). This is a general guide, and it can vary significantly with variations in concrete mix design and type of application. The radius of action is the distance from the vibrator head within which consolidation occurs.

ADJUSTING THE BACKPACK

The backpack has a number of straps that let you adjust your load for maximum comfort.

Frame

The adjustable frame allows you to position the straps to fit your body.

1. Loosen and pull out the Velcro closure.
2. Put the harness strap into the right position, then lace the straps through the 4 attachment loops. Tighten the strap and secure the Velcro closure.

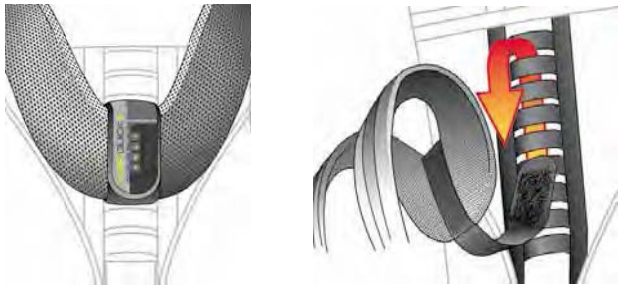

Hip Belt

1. Loosen all of the straps on the harness system and position the hip belt so the top of the iliac crest is about 1" down from the top of the hip belt. Correct positioning will direct the weight onto your hips.
2. Put the pack on your back so that the hip belt is resting over your hip bones.
3. Close the hip belt buckle and tighten it.
4. Check the padded sections of the hip belt to make sure they wrap around your hips comfortably. Keep at least 1" of clearance on either side of the center buckle.

Shoulder Straps

Pull down and back on the ends of the shoulder straps to tighten them.

Shoulder straps should fit closely to hold the pack body against your back, keeping the load forward. They should NOT carry the weight.

Load Lifters

Load-lifter straps are located just below the tops of your shoulders (near your collarbones) and should angle back toward the pack body at a 45° angle.

Gently snug the load-lifter straps to pull weight off your shoulders. (Overtightening the load lifters will cause a gap to form between your shoulders and the shoulder straps.)

Sternum Strap

Adjust the sternum strap as needed to a comfortable height across your chest.

Buckle the sternum strap and tighten until the shoulder straps are pulled inwards comfortably from your shoulders, allowing your arms to move freely.

Pull the stabilizer straps located on either side of the hip belt to snug the pack body toward the hip belt and stabilize the load.

Final Tweaks

Pull the stabilizer straps, located on either side of the hip belt, to snug the pack body toward the hip belt and stabilize the load.

Go back to the shoulder straps and carefully take a bit of tension off of them. This ensures the majority of the weight is carried by your hips.

PRE-OPERATION CHECKS

Is Your Engine Ready to Go?

For your safety, and to maximize the service life of your equipment, take a few minutes before you operate the engine to check its condition. Take care of any problems you find, or have your servicing dealer correct them, before you operate the engine.

⚠ WARNING

IMPROPERLY MAINTAINING THE ENGINE, OR FAILURE TO CORRECT A PROBLEM BEFORE OPERATION, CAN CAUSE A MALFUNCTION IN WHICH YOU COULD BE SERIOUSLY INJURED OR KILLED. ALWAYS PERFORM A PRE-OPERATION INSPECTION BEFORE EACH OPERATION AND CORRECT ANY PROBLEM.

Before beginning your pre-operation checks, be sure the engine is level and the engine switch is in the OFF position. Always check the following items before you start the engine:

Check the General Condition of the Engine

1. Look around and underneath the engine for signs of oil or gasoline leaks.
2. Remove any excessive dirt or debris, especially around the muffler and recoil starter.
3. Look for signs of damage.
4. Check that all shields and covers are in place, and all nuts, bolts and screws are tightened.

Check the Engine

1. Check the fuel level (see [“Refueling” on page 11](#)). Starting with a full tank will help to eliminate or reduce operating interruptions for refueling.
2. Check the engine oil level (see [“Engine Oil” on page 12](#)). Running the engine with a low oil level can cause engine damage.

The Oil Alert system (applicable types) will automatically stop the engine before the oil level falls below safe limits. However, to avoid the inconvenience of an unexpected shutdown, always check the engine oil level before startup.

3. Check the air filter element (see [“Air Cleaner” on page 13](#)). A dirty air filter element will restrict air flow to the carburetor, reducing engine performance.
4. Check the equipment powered by this engine.

Review the instructions provided with the equipment powered by this engine for any precautions and procedures that should be followed before engine startup.

Check the Throttle Lever

The throttle lever controls the speed of the engine. Push it forward to increase the engine speed. Pull it back to decrease the engine speed. The lever is an orange hand control located on the left side of the backpack.

IMPORTANT

*The engine will **not** start if the throttle lever is all the way back in the OFF position. Push the lever forward about 1/2" into the SLOW position to engage it.*

OPERATION

Safe Operating Precautions

Before operating the engine for the first time, please review the [“Safety” on page 5](#) and [“Pre-Operation Checks” on page 7](#).

⚠ WARNING

CARBON MONOXIDE GAS IS TOXIC. BREATHING IT CAN CAUSE UNCONSCIOUSNESS AND EVEN DEATH. AVOID ANY AREAS OR ACTIONS THAT EXPOSE YOU TO CARBON MONOXIDE.

Vibrator Heads rotate at twice the speed of the engine and are designed for nominal speeds of 12,000...13,000 RPM (Engine speed of 6,000...6,500 RPM). Operating at excessive speeds may reduce the performance or life of the product.

Starting the Engine

Move the fuel valve to the ON position.

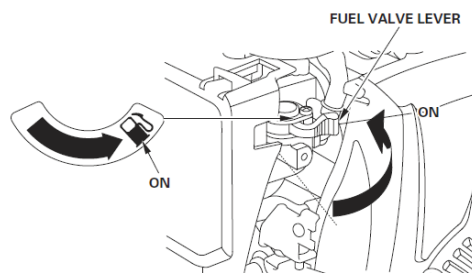

To start a cold engine, move the choke lever to the CLOSED position. To restart a warm engine, leave the choke lever in the OPEN position.

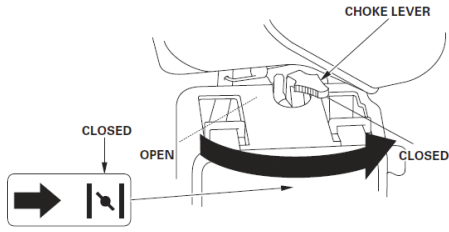

Turn the engine switch to the ON position.

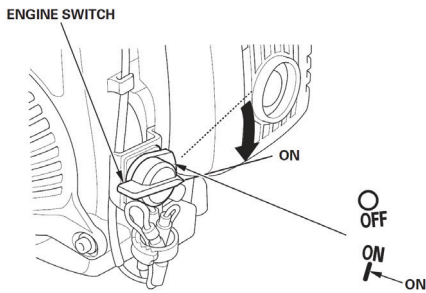

Set the throttle lever to the SLOW position. Pull the starter grip lightly until you feel resistance, then pull briskly. Return the starter grip gently.

NOTE: Do not allow the starter grip to snap back against the engine. Return it gently to prevent damage to the starter.

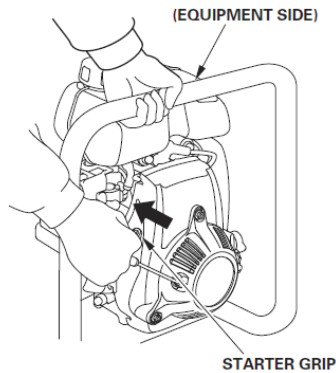

If the choke lever has been moved to the CLOSED position to start the engine, gradually move it to the OPEN position as the engine warms up.

IMPORTANT

The engine will **not** start if the throttle lever is all the way back in the OFF position. Push the lever forward about 1/2" into the SLOW position to engage it.

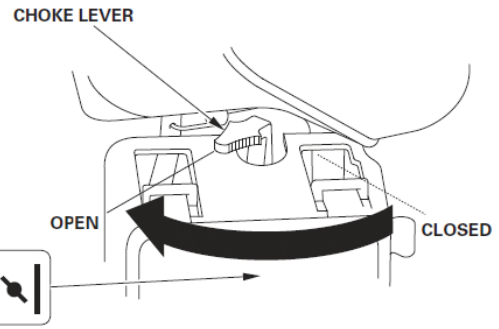

Setting the Engine Speed

Position the throttle lever for the desired engine speed.

Vibrator heads rotate at twice the speed of the engine and are designed for nominal speeds of 12,000...13,000 RPM (Engine speed of 6,000...6,500 RPM). Operating at excessive speeds may reduce the performance or life of the product.

Maximum engine speed will change with the size of the vibrator head and shaft. Use the engine governor screw to adjust the throttle range within safe operational limits.

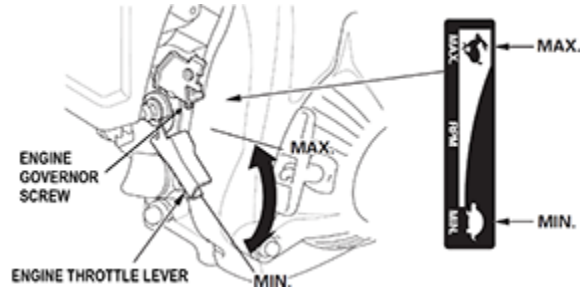

The engine throttle lever is controlled by the orange throttle lever on the left side of the backpack. The throttle lever should be set to SLOW for startup, FAST for operation, and STOP for shutdown.

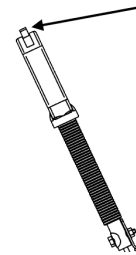

Using the Tachometer

The tachometer records engine hours and speed.

Press and release the tachometer button to toggle between *Hours*, *Tach* and *Service* modes.

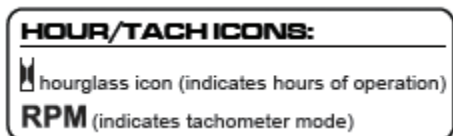

To view the number of engine starts: In *Hours* mode (hourglass icon on left side of screen), hold down the button. The screen will display the number of Engine Starts.

To view the maximum RPM display: On the *RPM* screen, press and hold the button until *Max 2RPM* is displayed. This is your Max RPM.

To clear the maximum RPM, continue to hold the button until "00000" displays.

Stopping the Engine

To stop the engine in an emergency, simply turn the engine switch to the OFF position. Under normal conditions, use the following procedure.

1. Move the orange throttle lever to the STOP position.
2. Turn the engine switch to the OFF position.

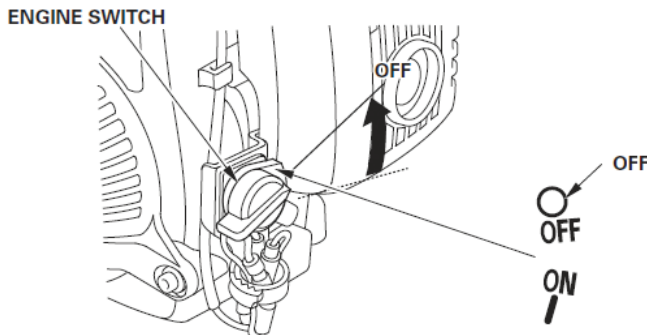

3. Turn the fuel valve lever to the OFF position.

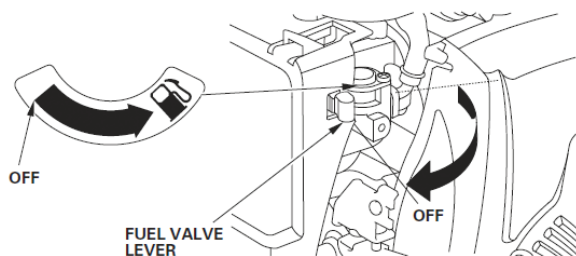

MAINTENANCE

Flex Shaft Grease

After each 50 hours of use, re-grease the flex shaft with Wyco synthetic shaft grease #514B.

Vibrator Head Lubricant

If the vibrator head used is oil lubricated, after 50 hours of use, change oil with Wyco lubricant #514-O.

Speed In increaser Servicing

After 250 hours of operation, the speed increaser assembly should be disassembled, thoroughly cleaned and reassembled with 1 ounce of Wyco gear oil SF 1000 (Wyco part number W402151, 8 oz.) While disassembled, check to see if the centrifugal clutch or the clutch drum need replacing due to wear. Use the Wyco drawings at the back of this manual as a reference while assembling and disassembling.

1. Remove 4-1/4-28x3.0 long *socket head cap screws* (Wyco part number W402555) and the *split ring lock washers* (Wyco part number W402117) from the *speed increaser housing* (Wyco part number W402548) that attach it to the Honda GXH50 engine, and disconnect the *speed increaser housing* from the motor.
2. Remove 4 #10-24x2.25 long *socket head cap screws* (Wyco part number W402626) and the *split ring lock washers* (Wyco part number W402XX) from the *motor adapter housing* (Wyco part number W402153) and allow the gear oil to drain from the gear housing.
3. Remove the *gear oil plug* (Wyco part number W402152), the *nylon washer* (Wyco part number W402153) and allow the gear oil to drain from the gear housing.
4. Clamp the *speed increaser housing* into a vise to secure it while removing the internal components.
5. Hold the *clutch drum* (Wyco part number W402546) in place using a chain or oil filter style strap wrench and unscrew the *hex driver* on the opposite end using a 5/16" allen wrench.
6. When the *clutch drum* is removed, it will allow for removal of the *bearing adapter retainer plate* (Wyco part number W402610). This plate lifts off and interfaces with an *O-ring* (Wyco part number W402550). Remove the *O-ring* to allow for removal of the *input gear assembly* (Wyco part number W402549).
7. Tap on the *internal gear* through the plug hole on the base of the speed increaser to loosen and remove the *input gear assembly*.
8. Remove the *snap ring* (Wyco part number W402557) that holds the *output gear assembly* in place and remove the assembly from the housing.

9. Inspect the gear teeth and verify they are not worn. Check the bearings to verify they are functional—turning smoothly and freely. If either is worn, replace them both.

IMPORTANT

If EITHER the gear teeth OR the bearings are worn, replace them BOTH at the same time with Wyco part numbers W402549 and W402620.

10. Clean the internal surfaces of the gear increaser housings, including the O-ring groove (Wyco part numbers W402548, W402602, W402610 and W401612) before reassembly.
11. Press the *output gear assembly* into place and install the *snap ring* (Wyco part number W402557) in place to prevent it from backing out.
12. Insert the *input gear assembly* into the cavity in the *speed increaser housing*. You may need to use a 5/16" hex driver to rotate the output shaft to align the gear before the *input gear assembly* drops into the correct position.
13. Install a new *O-ring* (Wyco part number W402550) into the groove around the bearing adapter.
14. Position the *bearing adapter plate* (Wyco part number W402610) into the mating groove so it contacts the *bearing adapter* (Wyco part number W402602).
15. Align the *motor mounting bracket* (Wyco part number W402549) so the 4 holes for the #10-24 bolts align with the threaded blind holes on the *speed increaser housing* (Wyco part number W402548).
16. Apply Loctite 242 (or equivalent thread locker) onto the threads of four #10-24x2.25L SHCS. Place the screws into the clearance holes on the *motor mounting bracket* (Wyco part number W402549) and torque to 25 in-lb.
17. Align the *clutch drum* (Wyco part number W402546) with the mating threads on the *input gear* (Wyco part number W402614) and apply 40 ft-lb of torque to tighten.
18. Put 2 ounces of *gear oil* (Wyco part number W402151) into the *gear increaser housing* through the 1/4-28 bolt hole on the housing, opposite the motor mounting bracket.
19. Install the 1/4" *nylon washer* (Wyco part number W401253) and the 1/4-28x0.25 *button cap screw* (Wyco part number W402152) and torque to 50 in-lb.
20. Align the motor bracket geometry with that on the Honda GXH50 engine. Apply Loctite 242 or equivalent onto the bolt threads and slide four 1/4" *lock washers* (Wyco part number W402117) onto the bolts. Insert four 1/4-28x3.00 long *alloy steel bolts* (Wyco part number W402555) into the clearance holes, and torque to 10 ft-lb.

Honda Engine GXH50

Follow the recommendations in the Honda engine Owner's Manual for their GXH50 engine regarding, but not limited to, the spark plug and air filter service.

SERVICING THE ENGINE

The Importance of Maintenance

Good maintenance is essential for safe, economical and trouble-free operation. It also helps reduce pollution.

WARNING

IMPROPER MAINTENANCE, OR FAILURE TO CORRECT A PROBLEM BEFORE OPERATION, CAN CAUSE A MALFUNCTION IN WHICH YOU CAN BE SERIOUSLY HURT OR KILLED.

ALWAYS FOLLOW THE INSPECTION AND MAINTENANCE RECOMMENDATIONS AND SCHEDULES IN THIS MANUAL.

To help you properly care for your engine, the following pages include a maintenance schedule, routine inspection procedures, and simple maintenance procedures using basic hand tools. Other service tasks that are more difficult, or require special tools, are best handled by professionals and are normally performed by a Honda technician or other qualified mechanic.

The maintenance schedule applies to normal operating conditions. If you operate your engine under severe conditions, such as sustained high-load or high-temperature operation, or use in unusually wet or dusty conditions, consult your servicing dealer for recommendations applicable to your individual needs and use.

Maintenance, replacement, or repair of the emission control devices and systems may be performed by any engine repair establishment or individual, using parts that are "certified" to EPA standards.

Maintenance Safety

Some of the most important safety precautions follow. However, we cannot warn you of every conceivable hazard that can arise in performing maintenance. Only you can decide whether or not you should perform a given task.

Good maintenance is essential for safe, economical and trouble-free operation. It also helps reduce pollution.

WARNING

FAILURE TO PROPERLY FOLLOW MAINTENANCE INSTRUCTIONS AND PRECAUTIONS CAN CAUSE YOU TO BE SERIOUSLY HURT OR KILLED. ALWAYS FOLLOW THE PROCEDURES AND PRECAUTIONS IN THIS MANUAL.

Safety Precautions

- Make sure the engine is off before you begin any maintenance or repairs. This will eliminate several potential hazards:

◆ **Carbon monoxide poisoning from engine exhaust.**

Operate outside away from open windows or doors.

◆ **Burns from hot parts.**

Let the engine and exhaust system cool before touching.

◆ **Injury from moving parts.**

Do not run the engine unless instructed to do so.

- Read the instructions before you begin, and make sure you have the tools and skills required.
- To reduce the possibility of fire or explosion, be careful when working around gasoline. Use only a non-flammable solvent, not gasoline, to clean parts. Keep cigarettes, sparks and flames away from all fuel-related parts.

Remember that an authorized Honda servicing dealer knows your engine best and is fully equipped to maintain and repair it.

To ensure the best quality and reliability, use only new genuine Honda parts or their equivalents for repair and replacement.

Maintenance Schedule

Regular Service Period (1) Perform at every indicated month or operating hour interval, whichever comes first.		Each use	First month or 10 hr	Every 3 months or 25 hr	Every 6 months or 50 hr	Every year or 100 hr	Every 2 years or 300 hr
Engine oil	Check level	X					
	Change		X		(3)		
Air filter	Check	X					
	Clean			X (2)			
Spark plug	Check, adjust					X	
	Replace						X
Spark arrester (applicable types)	Clean					X	
Fuel tank and filter	Clean					X (4)	
* Idle speed	Check, adjust						
* Valve clearance	Check, adjust					X (4)	
*Combustion chamber	Clean						X (4)
* Fuel tube	Check						

* See the Honda Owner's Manual.

- (1) For commercial use, log hours of operation to determine proper maintenance intervals.
- (2) Service more frequently when used in dusty areas.
- (3) Change engine oil every 25 hours when used under heavy load or in high ambient temperatures.
- (4) These items should be serviced by your Honda servicing dealer, unless you have the proper tools and are mechanically proficient. See the Honda Owner's Manual for service procedures.

Failure to follow this maintenance schedule could result in non-warrantable failures.

Refueling

Recommended Fuel

Unleaded gasoline	
U.S.	Pump octane rating 86 or higher
Except U.S.	Research octane rating 91 or higher
	Pump octane rating 86 or higher

This engine is certified to operate on unleaded gasoline with a pump octane rating of 86 or higher (a research octane rating of 91 or higher).

Refuel in a well-ventilated area with the engine stopped. If the engine has been running, allow it to cool first. Never refuel the engine inside a building where gasoline fumes may reach flames or sparks.

You may use regular unleaded gasoline containing no more than 10% Ethanol (E10) or 5% Methanol by volume. In addition, Methanol must contain co-solvents and corrosion inhibitors. Use of fuels with content of Ethanol or Methanol greater than shown above may cause starting and/or performance problems. It may also damage metal, rubber, and plastic parts of the fuel system. Engine damage or performance problems that result from using a fuel with percentages of Ethanol or Methanol greater than shown above are not covered under the warranty.

WARNING

GASOLINE IS HIGHLY FLAMMABLE AND EXPLOSIVE, AND YOU CAN BE BURNED OR SERIOUSLY INJURED WHEN REFUELING.

- **STOP ENGINE AND KEEP HEAT, SPARKS, AND FLAME AWAY.**
- **REFUEL ONLY OUTDOORS.**
- **WIPE UP SPILLS IMMEDIATELY.**

NOTE: Fuel can damage paint and some types of plastic. Be careful not to spill fuel when filling your fuel tank. Damage caused by spilled fuel is not covered under the Distributor's Limited Warranty. Move at least 1 meter (39 inches) away from the fueling source and site before starting the engine.

1. With the engine stopped and on a level surface, remove the fuel filler cap and check the fuel level. Refill the tank if the fuel level is low.
2. Add fuel to the bottom of the fuel level mark of the fuel tank. Do not overfill. Wipe up spilled fuel before starting the engine.

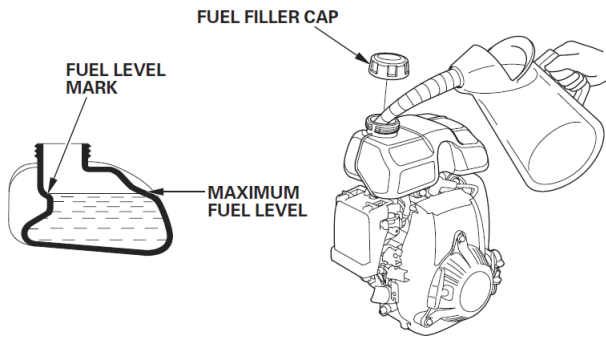

3. Refuel carefully to avoid spilling fuel. Do not fill the fuel tank completely. It may be necessary to lower the fuel level depending on operating conditions. After refueling, tighten the fuel filler cap securely.

Keep gasoline away from appliance pilot lights, barbecues, electric appliances, power tools, and anything else that may generate a spark. Spilled fuel is a fire hazard and causes environmental damage. Wipe up spills immediately.

Engine Oil

Oil is a major factor affecting performance and service life. Use a 4-stroke automotive detergent oil. Use a funnel with a long spout to add oil.

Recommended Oil

Use 4-stroke motor oil that meets or exceeds the requirements for API service category SJ or later (or equivalent). Always check the API service label on the oil container to be sure it includes the letters SJ or later (or equivalent).

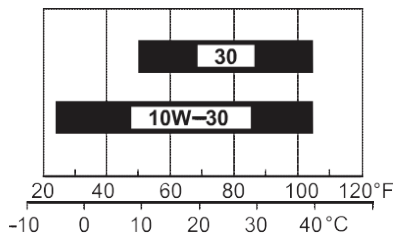

SAE 10W-30 is recommended for general use. Other viscosities shown in the chart may be used when the average temperature in your area is within the indicated range.

Oil Level Check

Check the engine oil level with the engine stopped and in a level position.

1. Remove the oil filler cap/dipstick and wipe it clean.
2. Insert the oil filler cap/dipstick into the oil filler neck as shown, but do not screw it in, then remove it to check the oil level
3. If the oil level is near or below the lower limit mark on the dipstick, fill with the recommended oil (see

“Recommended Oil” on page 12) to the upper limit mark on the bottom edge of the oil fill hole. Do not overfill.

4. Reinstall the oil filler cap/dipstick.

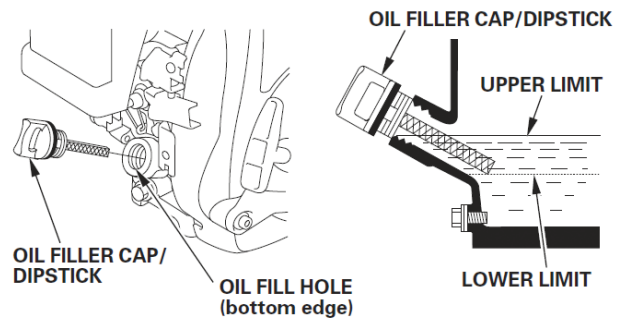

NOTE: Running the engine with a low oil level can cause engine damage. This type of damage is not covered by the Distributor’s Limited Warranty.

The Oil Alert system (applicable types) will automatically stop the engine before the oil level falls below the safe limit. However, to avoid the inconvenience of an unexpected shutdown, always check the engine oil level before startup.

Oil Change

Drain the used oil when the engine is warm. Warm oil drains quickly and completely. Use a funnel with a long spout to add oil.

1. Place a suitable container below the engine to catch the used oil, then remove the oil filler cap/dipstick, oil drain plug and washer.
2. Allow the used oil to drain completely, then reinstall the oil drain plug and new washer, and tighten the oil drain plug securely.

Please dispose of used motor oil in a manner that is compatible with the environment. We suggest you take used oil in a sealed container to your local recycling center or service station for reclamation. Do not throw it in the trash, pour it on the ground, or pour it down a drain.

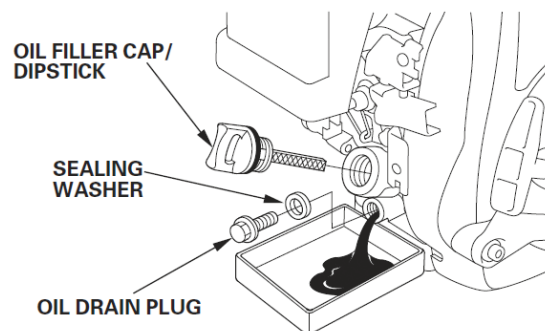

3. With the engine in a level position, fill with the recommended oil (see *“Recommended Oil” on page 12*) to the upper limit mark (bottom edge of the oil fill hole).

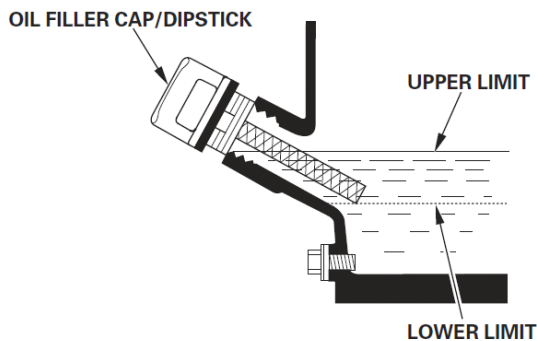

NOTE: Running the engine with a low oil level can cause engine damage. This type of damage is not covered by the Distributor's Limited Warranty.

4. Reinstall the oil filler cap/dipstick securely.

Air Cleaner

A dirty air cleaner will restrict air flow to the carburetor, reducing engine performance. If you operate the engine in very dusty areas, clean the air filter more often than specified in the "Maintenance Schedule" on page 11.

NOTE: Operating the engine without an air filter, or with a damaged air filter, will allow dirt to enter the engine, causing rapid engine wear. This type of damage is not covered by the Distributor's Limited Warranty.

Inspection

Remove the air cleaner cover and inspect the filter element. Clean or replace a dirty filter element. Always replace a damaged filter element.

Cleaning

1. Clean the filter element in warm soapy water, rinse, and allow to dry thoroughly. Or clean the filter element in a non-flammable solvent and allow to dry.
2. Dip the filter element in clean engine oil, then squeeze out all excess oil. The engine will smoke when started if too much oil is left in the element.
3. Wipe dirt from the air cleaner body and cover, using a moist rag. Be careful to prevent dirt from entering the carburetor.

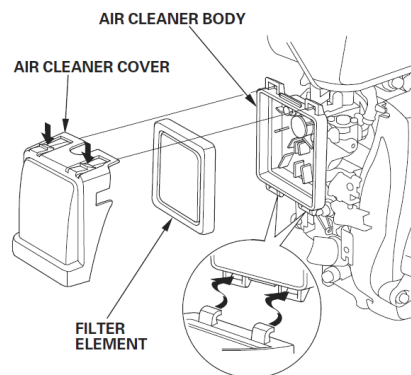

Spark Plug

Recommended Spark Plugs: CR5HSB (NGK) U16FSR-UB (DENSO) SCHEDULE.

NOTE: An incorrect spark plug can cause engine damage.

For good performance, the spark plug must be properly gapped and free of deposits.

1. Disconnect the spark plug cap and remove any dirt from round the spark plug area.
2. Remove the spark plug with a 5/8" spark plug wrench.

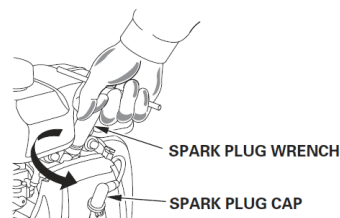

3. Inspect the spark plug. Replace it if it is damaged or badly fouled, if the sealing washer is in poor condition, or if the electrode is worn.
4. Measure the spark plug electrode gap with a wire-type feeler gauge. Correct the gap, if necessary, by carefully bending the side electrode. The gap should be 0.024...0.028" (0.60...0.70 mm).

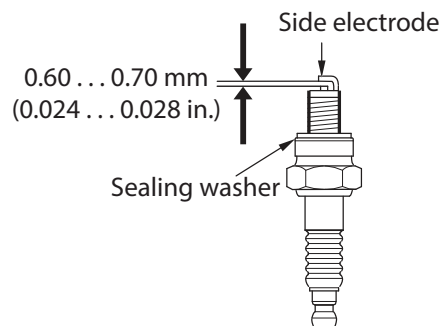

5. Install the spark plug carefully, by hand, to avoid cross-threading.

6. After the spark plug is seated, tighten with a 5/8" spark plug wrench to compress the sealing washer.
7. When installing a new spark plug, tighten 1/2 turn after the spark plug seats to compress the washer.
8. When reinstalling the original spark plug, tighten 1/8 to 1/4 turn after the spark plug seats to compress the washer.

NOTE: A loose spark plug can overheat and damage the engine. Overtightening the spark plug can damage the threads in the cylinder head.

9. Attach the spark plug cap to the spark plug.

Spark Arrester (Optional Equipment)

Your engine is not factory-equipped with a spark arrester. In some areas, it is illegal to operate an engine without a spark arrester. Check local laws and regulations. A spark arrester is available from authorized Honda servicing dealers.

The spark arrester must be serviced every 100 hours to keep it functioning as designed.

If the engine has been running, the muffler will be hot. Allow it to cool before servicing the spark arrester.

Spark Arrester Removal

1. Remove the three 5 mm bolts from the muffler protector and remove the muffler protector.
2. Remove the special screw from the spark arrester, and remove the spark arrester from the muffler.

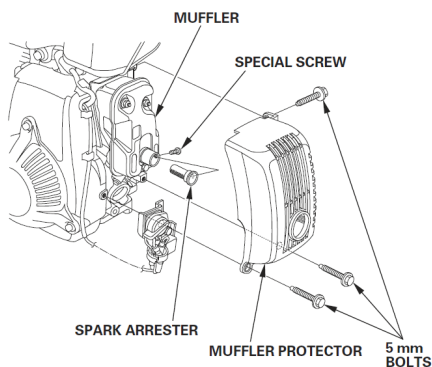

Spark Arrester Cleaning and Inspection

1. Use a brush to remove carbon deposits from the spark arrester screen. Be careful not to damage the screen. Replace the spark arrester if it has breaks or holes.

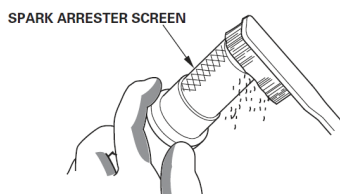

2. Install the spark arrester and muffler protector in the reverse order of disassembly.

HELPFUL TIPS AND SUGGESTIONS

Storing Your Engine

Engine Storage Preparation

Proper storage preparation is essential for keeping your engine trouble-free and looking good. The following steps will help to keep rust and corrosion from impairing your engine's function and appearance, and will make the engine easier to start when you use it again.

Engine Cleaning

If the engine has been running, allow it to cool for at least half an hour before cleaning. Clean all exterior surfaces, touch up any damaged paint, and coat other areas that may rust with a light film of oil.

NOTE: Using a garden hose or pressure washing equipment can force water into the air cleaner or muffler opening. Water in the air cleaner will soak the air filter, and water that passes through the air filter or muffler can enter the cylinder, causing damage.

Engine Fuel

Gasoline will oxidize and deteriorate in storage. Deteriorated gasoline will cause hard starting, and it leaves gum deposits that clog the fuel system. If the gasoline in your engine deteriorates during storage, you may need to have the carburetor and other fuel system components serviced or replaced.

The length of time that gasoline can be left in your fuel tank and carburetor without causing functional problems will vary with such factors as gasoline blend, your storage temperatures, and whether the fuel tank is partially or completely filled. The air in a partially filled fuel tank promotes fuel deterioration. Very warm storage temperatures accelerate fuel deterioration. Fuel deterioration problems may occur within a few months, or even less if the gasoline was not fresh when you filled the fuel tank.

Fuel system damage or engine performance problems resulting from neglected storage preparation are not covered under the Distributor's Limited Warranty.

You can extend fuel storage life by adding a gasoline stabilizer that is formulated for that purpose, or you can avoid fuel deterioration problems by draining the fuel tank and carburetor.

Adding a Gasoline Stabilizer to Extend Fuel Storage Life

When adding a gasoline stabilizer, fill the fuel tank with fresh gasoline. If only partially filled, air in the tank will promote fuel deterioration during storage. If you keep a container of gasoline for refueling, be sure that it contains only fresh gasoline.

1. Add gasoline stabilizer following the manufacturer's instructions.

2. After adding a gasoline stabilizer, run the engine outdoors for 10 minutes to be sure that treated gasoline has replaced the untreated gasoline in the carburetor.
3. Stop the engine, and move the fuel valve lever to the OFF position.

Draining the Fuel Tank and Carburetor

⚠ WARNING

GASOLINE IS HIGHLY FLAMMABLE AND EXPLOSIVE, AND YOU CAN BE BURNED OR SERIOUSLY INJURED WHEN HANDLING FUEL.

- **STOP ENGINE AND KEEP HEAT, SPARKS, AND FLAME AWAY.**
 - **HANDLE FUEL ONLY OUTDOORS.**
 - **WIPE UP SPILLS IMMEDIATELY.**
1. Place an approved gasoline container below the carburetor, and use a funnel to avoid spilling fuel.
 2. Drain the fuel tank and carburetor. Remove the carburetor drain bolt, then move the fuel valve to the ON position.

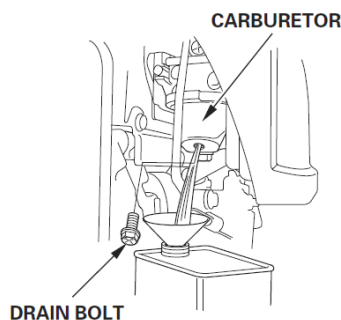

3. After all the fuel has drained into the container, reinstall the drain bolt (carburetor equipped with a drain bolt type only). Tighten the drain bolt or drain screw securely.

Engine Oil

Change the engine oil (see *"Engine Oil" on page 12*).

Engine Cylinder

1. Remove the spark plug (see *"Spark Plug" on page 13*).
2. Pour a tablespoon 5...10 cm³ (5...10 cc) of clean engine oil into the cylinder.
3. Pull the starter grip several times to distribute the oil in the cylinder.
4. Reinstall the spark plug.
5. Pull the starter grip slowly until resistance is felt and the rib on the flywheel aligns with the notch on the fan cover. This will close the valves so moisture cannot enter the engine cylinder. Return the starter grip gently.

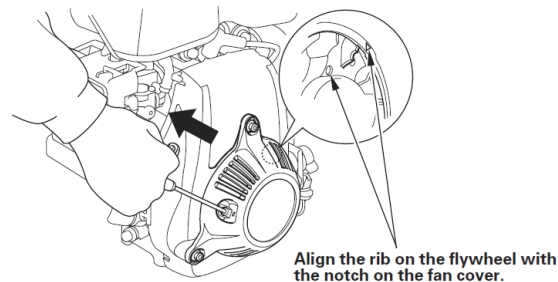

Storage Precautions

If your engine will be stored with gasoline in the fuel tank and carburetor, it is important to reduce the hazard of gasoline vapor ignition. Select a well-ventilated storage area away from any appliance that operates with a flame, such as a furnace, water heater, or clothes dryer. Also avoid any area with a spark-producing electric motor, or where power tools are operated.

If possible, avoid storage areas with high humidity, because that promotes rust and corrosion.

Keep the engine level in storage. Tilting can cause fuel or oil leakage.

With the engine and exhaust system cool, cover the engine to keep out dust. A hot engine and exhaust system can ignite or melt some materials. Do not use sheet plastic as a dust cover.

A nonporous cover will trap moisture around the engine, promoting rust and corrosion.

Removal from Storage

Check your engine as described in *"Is Your Engine Ready to Go?" on page 7*.

If the fuel was drained during storage preparation, fill the tank with fresh gasoline. If you keep a container of gasoline for refueling, be sure it contains only fresh gasoline. Gasoline oxidizes and deteriorates over time, causing hard starting.

If the cylinder was coated with oil during storage preparation, the engine will smoke briefly at startup. This is normal.

Transporting

If the engine has been running, allow it to cool for at least 15 minutes before loading the engine-powered equipment on the transport vehicle. A hot engine and exhaust system can burn you and can ignite some materials.

Keep the engine level when transporting to reduce the possibility of fuel leakage. Turn the fuel valve to the OFF position (see *"Pre-Operation Checks" on page 7*).

TROUBLESHOOTING

Engine Will Not Start	Possible Cause	Correction
Check control positions.	Fuel valve OFF.	Move lever to ON position.
	Choke open.	Move lever to CLOSED position unless the engine is warm.
	Engine switch OFF.	Turn engine switch to ON position.
Check engine oil level.	Engine oil level low (Oil Alert stops engine).	Fill with the recommended oil to the proper level. See "Engine Oil" on page 12.
Check throttle wire.	Throttle wire nipple is not engaged.	Verify that the throttle wire is engaged. See "Check the Throttle Lever" on page 7.
Check throttle position	Throttle is in STOP position	Move throttle to SLOW position. See "Setting the Engine Speed" on page 8.
Check fuel.	Out of fuel.	Refuel. See "Refueling" on page 11.
	Bad fuel; engine stored without treating or draining gasoline, or refueled with bad gasoline.	Drain fuel tank and carburetor. See "Draining the Fuel Tank and Carburetor" on page 15. Refuel with fresh gasoline. See "Refueling" on page 11.
Remove and inspect spark plug.	Spark plug faulty, fouled, or improperly gapped.	Gap or replace spark plug. See "Spark Plug" on page 13.
	Spark plug wet with fuel (flooded engine.)	Dry and reinstall the spark plug. Start the engine with the throttle lever in the MAX. position.
Take engine to an authorized Honda servicing dealer, or refer to the Owner's Manual.	Fuel filter restricted, carburetor malfunction, ignition malfunction, valves stuck.	Replace or repair faulty components.

Engine Lacks Power	Possible Cause	Correction
Check air filter.	Filter element restricted.	Clean or replace filter element. See "Air Cleaner" on page 13.
Check fuel.	Bad fuel; engine stored without treating or draining gasoline, or refueled with bad gasoline.	Drain fuel tank and carburetor. See "Draining the Fuel Tank and Carburetor" on page 15. Refuel with fresh gasoline. See "Refueling" on page 11.
Take engine to an authorized Honda servicing dealer, or refer to the Owner's Manual.	Fuel filter restricted, carburetor malfunction, ignition malfunction, valves stuck.	Replace or repair faulty components.
Check engine governor screw	Throttle cannot fully open	Back off the engine governor screw. See "Setting the Engine Speed" on page 8.

SERVICE

Repair or replacement parts can be ordered from Wyco Tool. Warranty repairs or chargeable repairs can be made by sending the product to the following address. Always obtain an RA number (Return Authorization) and include it in the address before returning any parts for warranty consideration or chargeable repair.

Phone: (262) 639-6770 or Toll free: (800) 233-9926

RA#

Wyco Tool

8635 Washington Avenue

Racine, Wisconsin 53406-3738

Engine parts may be obtained from your local Honda engine dealer.

Wyco Drawings

Description	Drawing #
Backpack assembly	W402558
Frame assembly	W402536
Speed increaser assembly	W402552

W402558 Backpack Assembly

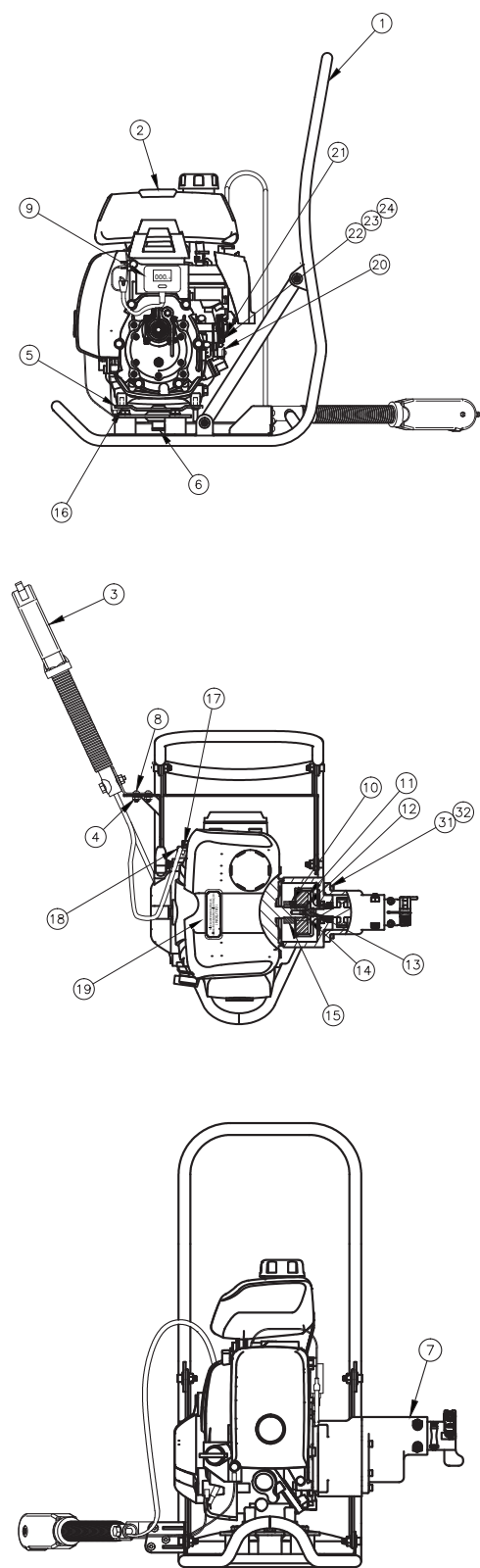

Item	Part Number	Qty	Description
1	W402536	1	Frame, steel, backpack, Honda; assembly
2	W402304	1	Engine, Honda; 50 cc 2.5 hp
3	W402333	1	Backpack, echo throttle control
4	W402306	3	Backpack, motor mount, locknut; #10-24
5	W402531	1	Assembly, bracket, Honda engine, backpack weld
6	W402109	1	Ring, retaining, external
7	W402552	1	Speed increaser assembly, gas back pack, Honda
8	W402313	3	Backpack throttle mount screw, #10-24 x 1/2" long
9	W402154	1	Meter, rpm/hour (with mounting screws)
10	W402315	2	Screw, set, 1/4-20; knurled cup point
11	W402316	1	Assembly, clutch, Honda backpack
12	W402317	1	Key, square; 3/16 x .875" Long
13	W402318	1	Screw, socket head cap, 1/4-28 x 1/2" long
14	W402168	1	Washer, flat, clutch
15	W402319	1	Collar, shaft; Honda backpack
16	W402320	4	Screw, flat socket head cap, M6 x 16 mm long
17	W402324	2	Backpack motor mount screw; #10-32 x 3/8" long
18	W402322	1	Clamp, throttle cable, Honda backpack
19	W402323	1	Backpack, Honda; caution label
20	W402325	1	Backpack, Honda; throttle spring plate
21	W402326	1	Backpack, Honda; throttle spring
22	W402523	1	Backpack, Honda; throttle/governor lever
23	W402327	1	Backpack, Honda; throttle swivel (mounted to item 24)
24	W402524	1	Washer; steel; zinc-plated; throttle
25*	W402181	3	Tie cable, mini, 4" x 0.100"
26*	W402522	6 in.	Silicone coated fiberglass sleeving, 0.085" ID, 100' roll
27*	W402521	1	Connector, bullet, 16-14 AWG, blue 0.156"; 0.178"; 1.00 in OAL, fully insulated, crimp terminal
28*	W402520	8 in.	Heat shrink tubing, 3/8" expanded, 1/4" recovered
29*	W402519	6 in.	Spiral wrap, 3/8" diameter
30 *	W402185	1	Nameplate, Ergopack
31	W402633	4	Screw, socket head cap; 1/4"-28 x 1.00" long; black oxide
32	W402117	4	Washer, lock, steel
33*	W402330	1	Wyco packaging; carton; backpack

* Parts not shown.

W402536 Frame Assembly

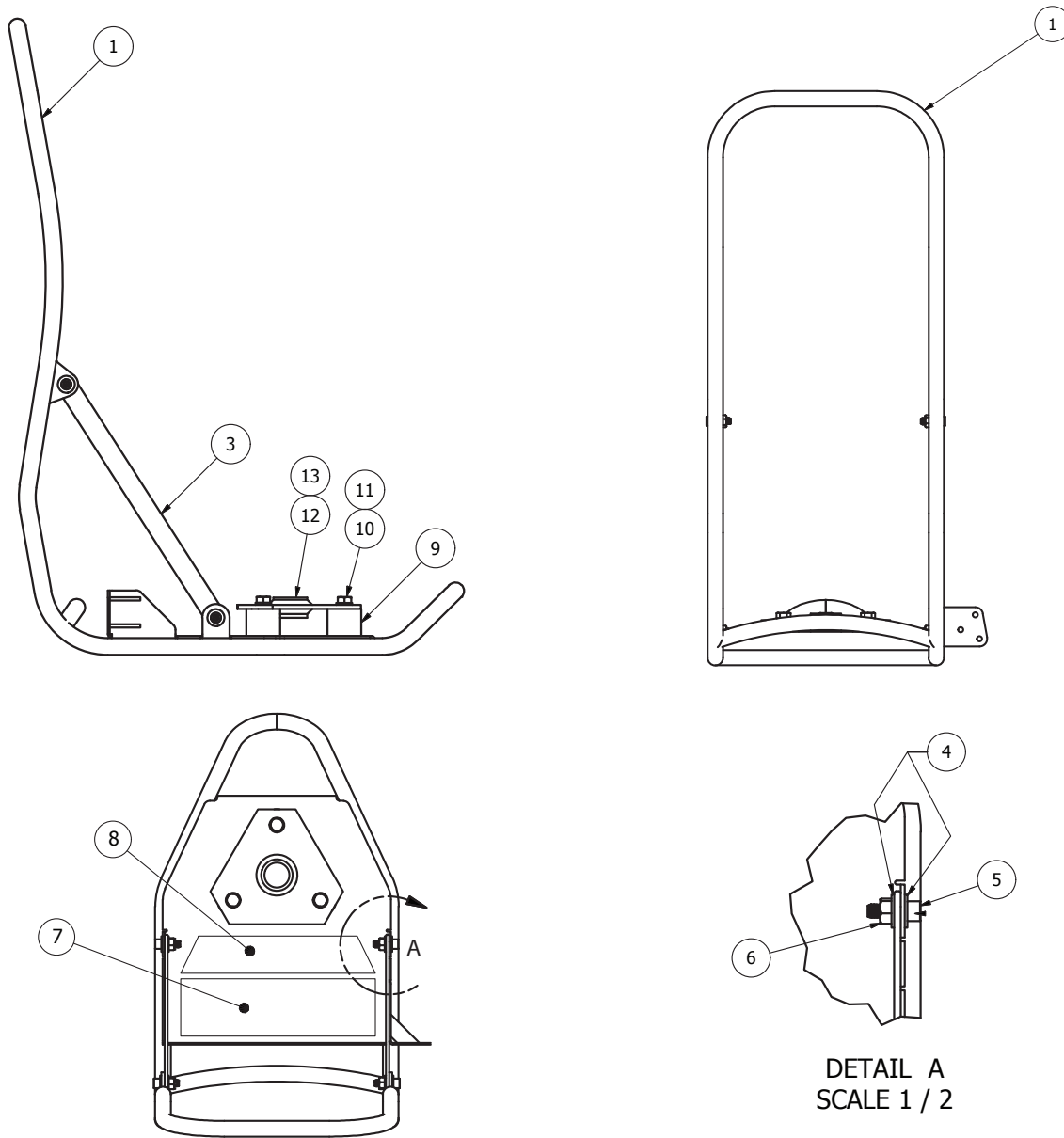

Item	Part Number	Qty	Description
1	W402540	1	Frame, weldment; backpack; Honda
2	W402533	1	Backpack frame Deuter
3	W402537	2	Brace; frame; backpack
4	W402527	8	Washer, flat, zinc plated, 1/4"
5	W402528	4	Screw, socket head, Nyloc, 1/4-20
6	W402529	4	Nut, zinc plated, 1/4-20
7	W402150	1	Decal, caution, backpack engine
8	W402184	1	Backpack, Ergopack
9	W402111	3	Isolator, rubber; backpack
10	W402108	6	Screw, HHCS, 5/16-18 x .5 in., grade 9
11	W883126	6	Washer, lock 5/16 in., zinc plated
12	W402538	1	Mounting plate, isolater; backpack
13	W402178	1	Bearing oil, IMPRG; bronze flange

W402552 Speed In increaser Assembly

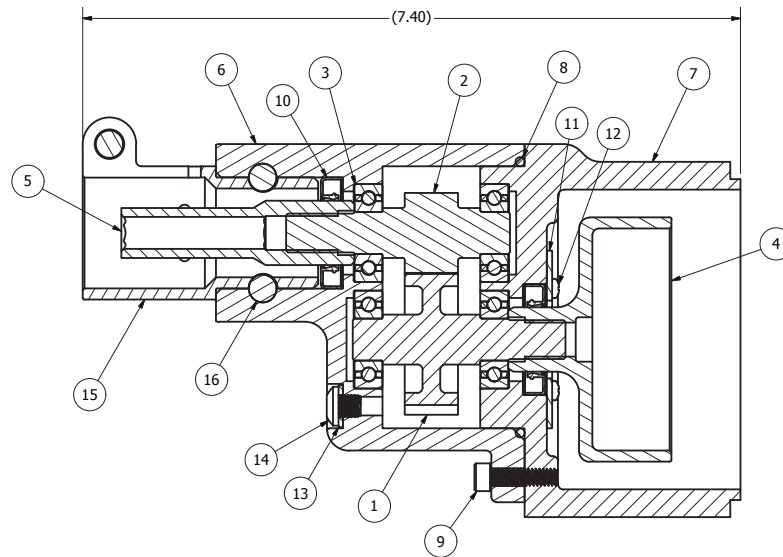

Item	Part Number	Qty	Description
1	W402543	1	Gear, input shaft
2	W402544	1	Gear, output shaft
3	W402545	4	Bearing
4	W402546	1	Drum, clutch
5	W402547	1	Drive, hex
6	W402548	1	Housing
7	W402549	1	Engine mount
8	W402550	1	O-ring, -144, viton
9	W402555	5	SHCS, 10-24 × 0.75 long
10	W402556	2	CRWA1 – radial shaft seal
11	W402551	1	Cover, seal retainer
12	W402557	4	Ring, retaining, internal
13	W402153	1	Washer, nylon; 4-40 × .25
14	W402152	1	Screw, button head cap; 1/4-28 x 0.25
15	W402630	1	Coupling, quick disconnect
16	W402625	2	Shoulder screw; socket head self-locking; 1/4"-20

Trademarks appearing in this document are the property of their respective entities.

Due to continuous research, product improvements and enhancements, Badger Meter reserves the right to change product or system specifications without notice, except to the extent an outstanding contractual obligation exists. © 2014 Badger Meter, Inc. All rights reserved.

wycosales@wycotool.com | www.wycotool.com

Phone: 262-639-6770 | Fax: 262-639-2023